

IF IT IS FOUND DESIRABLE TO CHANGE ANY TOLERANCE OR OTHER DETAIL SPECIFIED ON THIS DRAWING NOTIFY THE PURCHASER PROMPTLY.
 MAXIMUM ALLOWABLE TOLERANCES HAVE BEEN DETERMINED AND DEVIATIONS WILL BE CAUSE FOR REJECTION. REMOVE ALL BURRS AND SHARP EDGES

HOLES
 A = 1/64 DIA. REQ'D.
 10

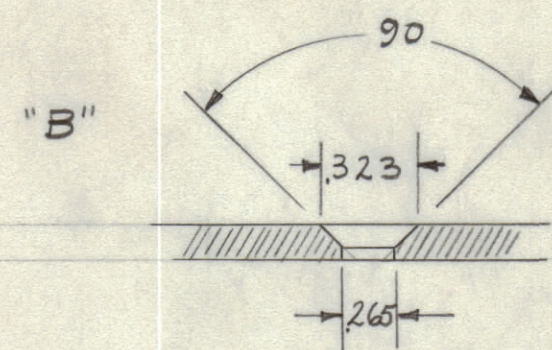

SM-107-3-4
 5-REQ'D.

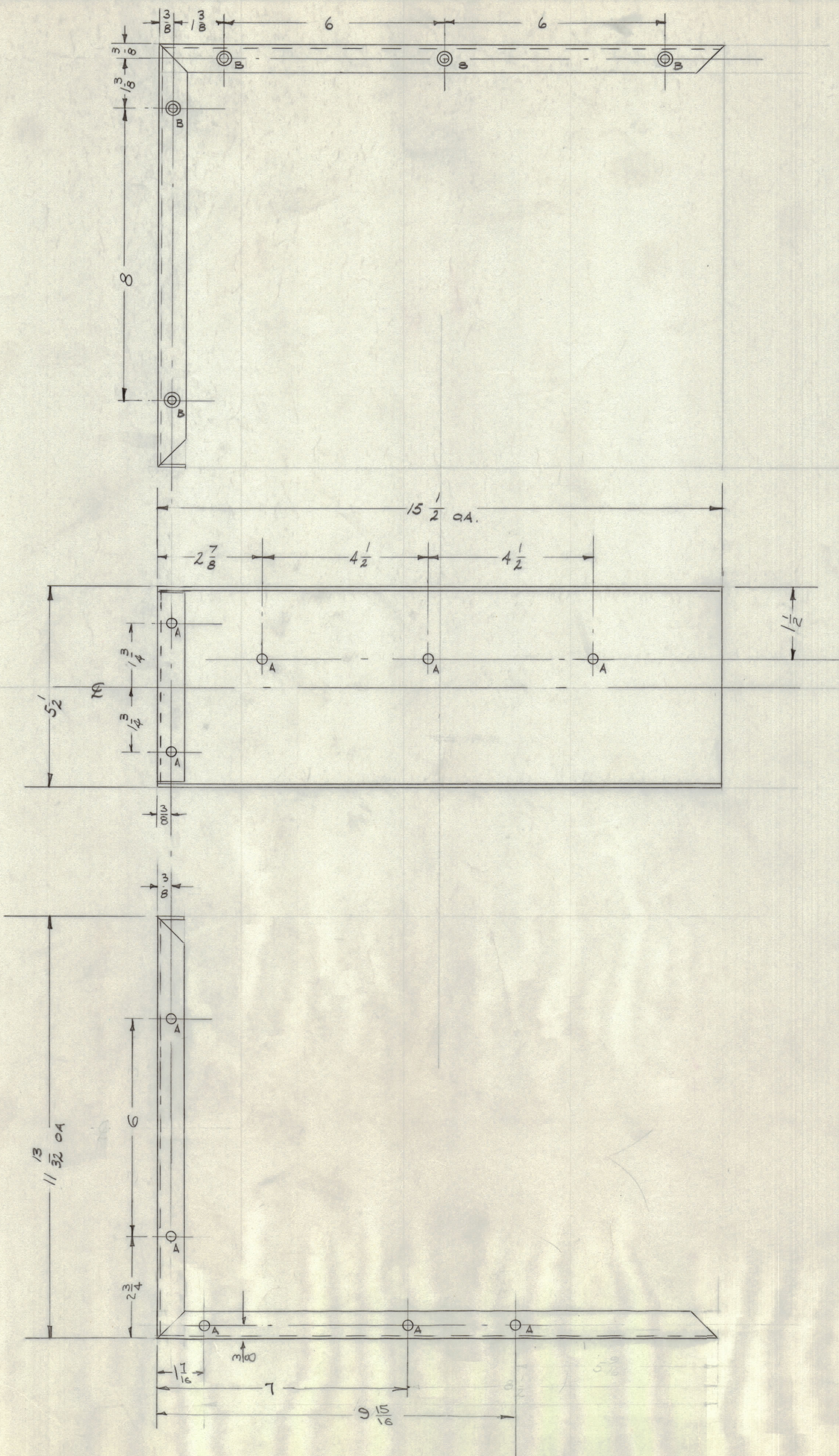

NOTICE TO PERSONS RECEIVING THIS DRAWING

THE TECHNICAL MATERIEL CORPORATION claims proprietary right in the material disclosed herein. This drawing is loaned in confidence for engineering information only and may not be reproduced or used to manufacture any item shown hereon without permission from THE TECHNICAL MATERIEL CORPORATION to the user. This drawing is loaned for mutual assistance and is subject to recall at any time.

Property of:
 THE TECHNICAL MATERIEL CORPORATION
 MAMARONECK, NEW YORK

ISSUE	ITEM	CHANGED FROM	DATE	CN. NO.	DRAFTS	CHECKER	ENG. APP.
TOLERANCES		SCALE:					
ALL	DEC. DIM. ±	DRILL, PUNCH, COMMERCIAL STOCK					
OTHERS	FRAC. DIM. ±	SIZES AND MANUFACTURERS					
	ANGULAR DIM. ±	TOLERANCES ARE NOT INCLUDED.					

1	GPT-10K			2-26-59
REQ PER UNIT	MODEL	PROJECT NO.	ASSY. NO.	DATE
USED ON				

REQ. ITEM	PART NO.	DESCRIPTION	SYMBOL
.081 THICK		THE TECHNICAL MATERIEL CORP.	
STOCK SIZE		MAMARONECK, NEW YORK	
ALUMINUM		WRAP AROUND, LINE FILTER	
MATERIAL	WEIGHT PER PC.		
5052-H32			GPT-10K
TYPE & TEMPER			
	DRAWN	ELEC. DES. APP.	MECH. DES. APP.
	ASD	MB	
	CHECKED		FINAL APPROVAL
HEAT TREAT. SPEC.			
S404 IRIDITE			MS-1619
FINISH & SPEC. NO.			