

**NOTICE TO PERSONS RECEIVING THIS DRAWING**

THE TECHNICAL MATERIEL CORPORATION claims proprietary right in the material disclosed hereon. This drawing is issued in confidence for engineering information only and may not be reproduced or used to manufacture anything shown hereon without permission from THE TECHNICAL MATERIEL CORPORATION to the user. This drawing is loaned for mutual assistance and is subject to recall at any time.

Property of:  
THE TECHNICAL MATERIEL CORPORATION  
MAMARONECK, NEW YORK

HOLES	SIZE	REQ'D	REQ'D
A	.078 DIA. (.078) DIA.	4	4
B	.120 DIA. (.120) DIA.	12	10
C	.169 DIA. (.169) DIA.	2	2
D	DRILL & TAP FOR 10-32	2	2
E	.196 DIA. (.196) DIA.	6	6
F	.703 DIA. DIA.	1	1

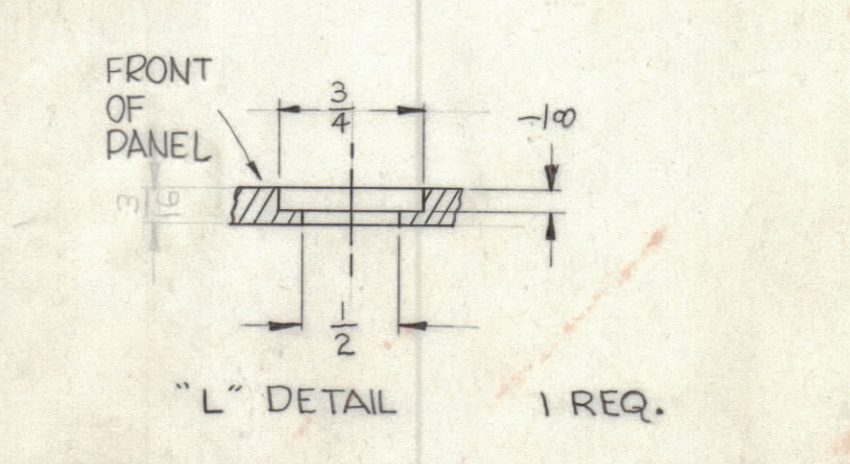
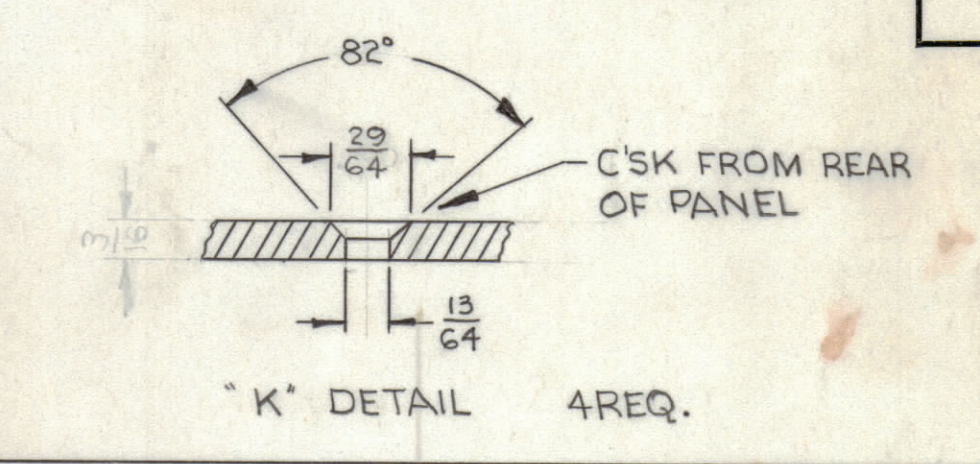
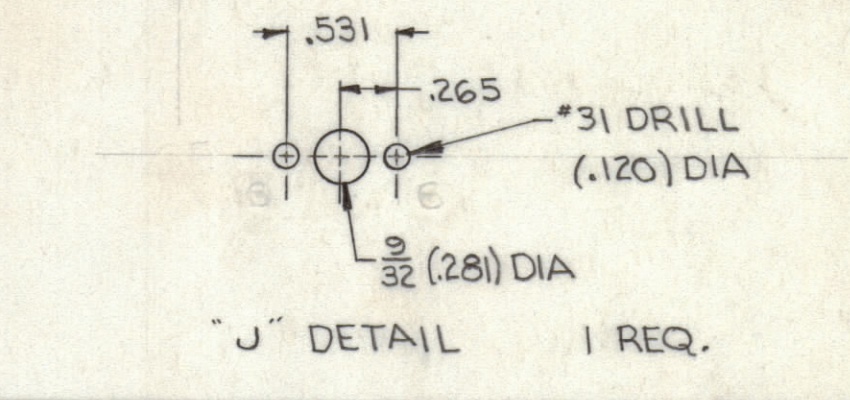
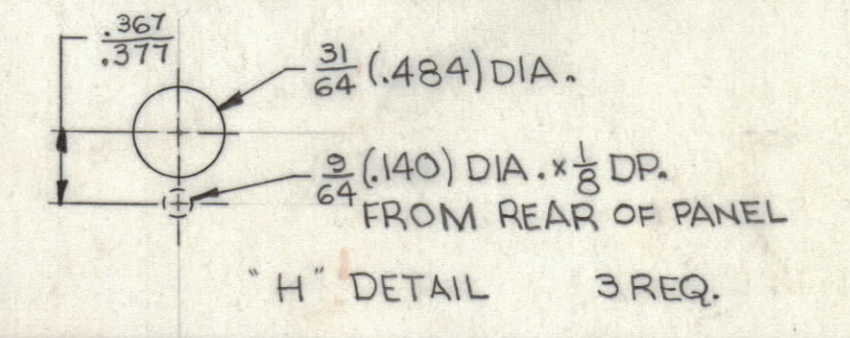
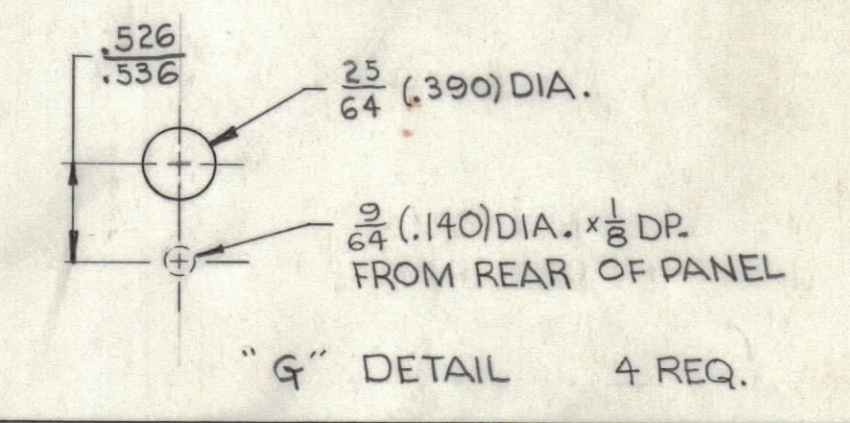
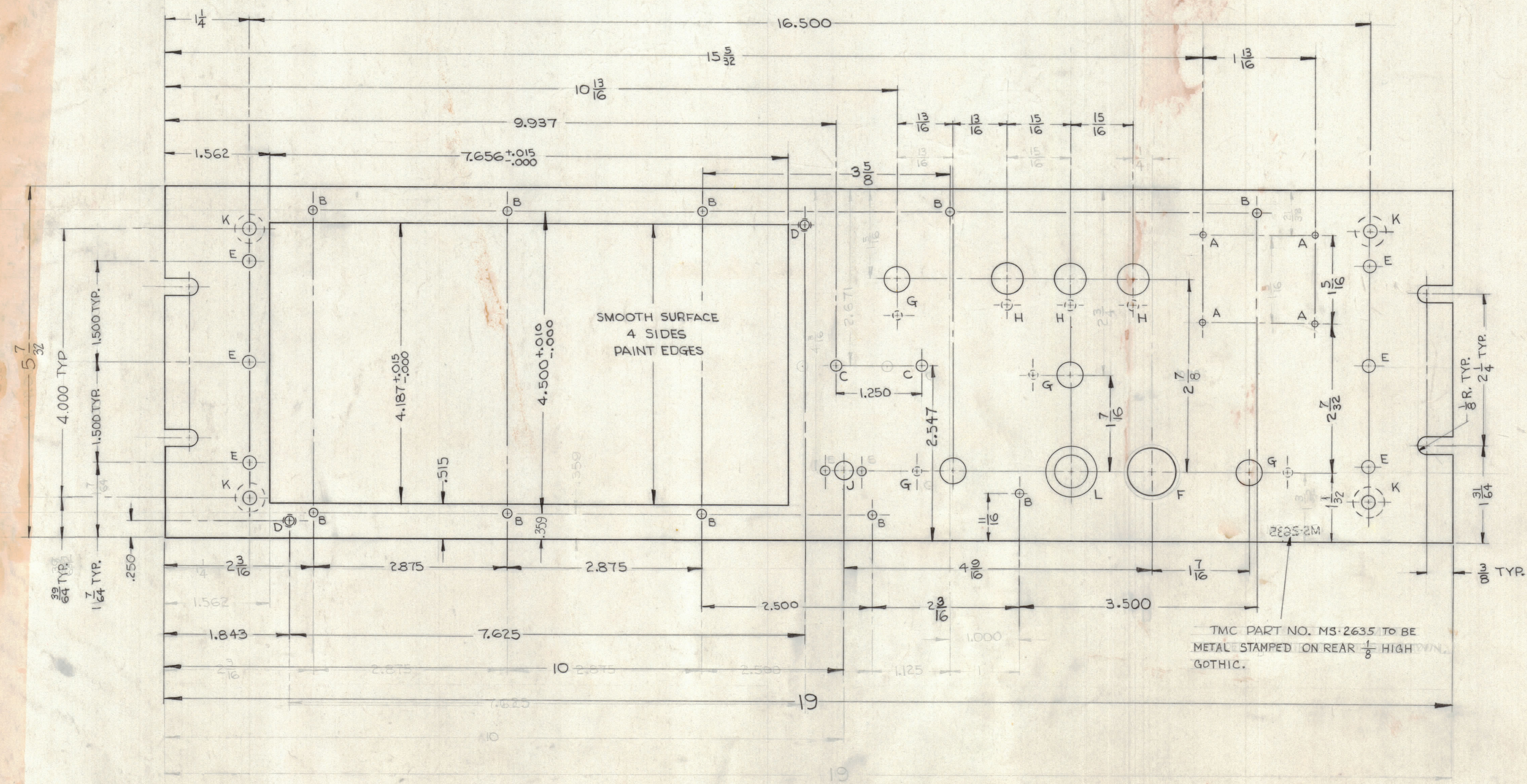

FRONT VIEW SHOWN

- MACHINING :**
- LATERAL BOW OF PANEL MUST BE KEPT TO .031 TOLERANCE.
  - MILL ALL EDGES.
  - HOLES MUST BE DRILLED.
  - PANEL MUST BE FREE OF ALL MACHINING MARKS, GOUGES AND SCRATCHES. IF NECESSARY SAND FRONT OF PANEL WITH NO.120 GRIT SANDPAPER.

- FINISH :**
- S404 - YELLOW IRIDITE
  - S114 - ZINC CHROMATE PRIMER
  - S115 - TMC SMOOTH GREY ENAMEL
- FRONT AND EDGES ONLY

DECIMALS	FRACTIONS	TOLERANCES
.1 ± .05	1/16 ± .005	± .005
.01 ± .005	1/32 ± .005	± .005
.001 ± .005	1/64 ± .005	± .005

SYM	ZONE	DESCRIPTION	DATE	CH. NO.	DRAFTS	CHECKER	ENG. APP.

UNLESS OTHERWISE SPECIFIED: DIMENSIONS ARE IN INCHES

SCALE DO NOT SCALE

MAXIMUM ALLOWABLE TOLERANCES HAVE BEEN DETERMINED AND ANY DEVIATIONS WILL BE CAUSE FOR REJECTION. REMOVE ALL BURRS & SHARP EDGES

REQ. PER UNIT	ITEM	SECTION	ASSY. NO.	DATE	TYPE & TEMPER	HEAT TREAT. SPEC.	FINISH & SPEC. NO.	ELEC. DES. APP.	MECH. DES. APP.	SHEET OF
1	FFR-35			7-26-61	2024-T3		SEE NOTES			MS 2635

REF. TMC DWG. NO. LD-960

REQ.	ITEM	PART NO.	DESCRIPTION	SYMBOL
		3/16 THICK	THE TECHNICAL MATERIEL CORP. MAMARONECK, NEW YORK	
		ALUMINUM	PANEL, FRONT	

R. TURCHIN  
DRAWN [initials] CHECKED [initials] FINAL APPROVAL [initials]

MS 2635