

FRONT VIEW

METAL STAMP TMC PART NO. 1/8 HIGH GOTHIC ON REAR OF PANEL, W/LATEST REVISION LETTER.

HOLE LEGEND	X	Y	REQ./ UNIT
"A"=3-48FHS	.224/.234	DR. #TAP 3-48	6
"B"=6-32FHS	.284/.289	.14	6

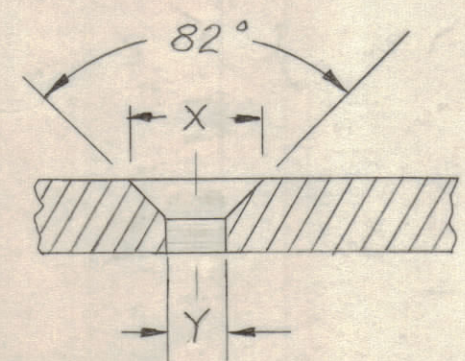

COUNTERSINK DETAIL FOR 3-48 & 6-32 F.H.S.

- C-1/4 X 29/64 SLOT 4 REG.
- D-#50 DRILL (OTO DIA.) 3 REQ.
- E-1/16 DIA. (SEE DETAIL) 4 REQ.
- F-5/64 DIA. 3 REQ.

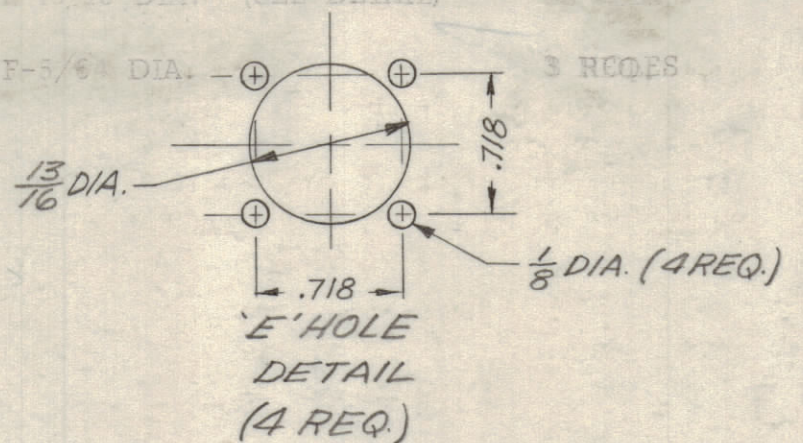

- FINISH:
- S-404-YEL. IRIDITE
 - S-114 -ZINC CHROMATE PRIMER
 - S-115 -SMOOTH GRAY ENAMEL

- NOTES:
1. LATERAL BOW OF PANEL MUST BE KEPT TO .031 TOL.
 2. HOLES MUST BE DRILLED
 3. MILL ALL EDGES.
 4. ALL THREADED HOLES & DIA. MUST BE HELD AFTER ETCHING.
 5. METAL TO BE FREE OF ALL SURFACE IMPERFECTIONS.

SYM	ZONE	DESCRIPTION	DATE	CH. NO.	DRAFTS	CHECKER	ENG. APP.
B		DIM & HOLE CHART CLARIFIED, ADD W/LAT. REV. TO TMC PT. NO.	10-4-66	16968	WHD	WHD	
A	D6	"Y" WAS .099 ("A" HOLE) LEGEND	10-2-61	5662	EE	EE	

UNLESS OTHERWISE SPECIFIED DIMENSIONS ARE IN INCHES AND INCLUDE CHEMICALLY APPLIED OR PLATED FINISHES

SCALE: MAXIMUM ALLOWABLE TOLERANCES HAVE BEEN DETERMINED AND ANY DEVIATIONS WILL BE CAUSE FOR REJECTION. REMOVE ALL BURRS & SHARP EDGES

DECIMALS	FRACTIONS
.X ± .05	± 1/64
.XX ± .01	ANGLES ± 0° 30'
.XXX ± .005	

REQ. PER UNIT	MODEL	SECTION	ASS'Y. NO.	DATE
1	QDP-34			9-13-61

REQ. ITEM	PART NO.	DESCRIPTION	SYMBOL
	3/16	THE TECHNICAL MATERIEL CORP. MAMARONECK, NEW YORK	
	STOCK SIZE		
	ALUMINUM	MACHINING, FRONT PANEL	
		MODEL QDP-34	
	2024-T3	WA	AB
	TYPE & TEMPER	DRAWN	CHECKED
	HEAT TREAT. SPEC.		FINAL APPROVAL
	SEE NOTE		MS 2663 B
	FINISH & SPEC. NO.	ELEC. DES. APP.	MECH. DES. APP.
		SHEET	OF