

IF IT IS FOUND DESIRABLE TO CHANGE ANY TOLERANCE SPECIFIED ON THIS DRAWING NOTIFY THE PURCHASER PROMPTLY.
 MAXIMUM ALLOWABLE TOLERANCES HAVE BEEN DETERMINED AND DEVIATIONS WILL BE CAUSE FOR REJECTION. REMOVE ALL BURRS AND SHARP EDGES.

A - 7/32 (218) D. 10 HOLES REQ.
 B - 1 (1.0) D. A HOLES REQ.

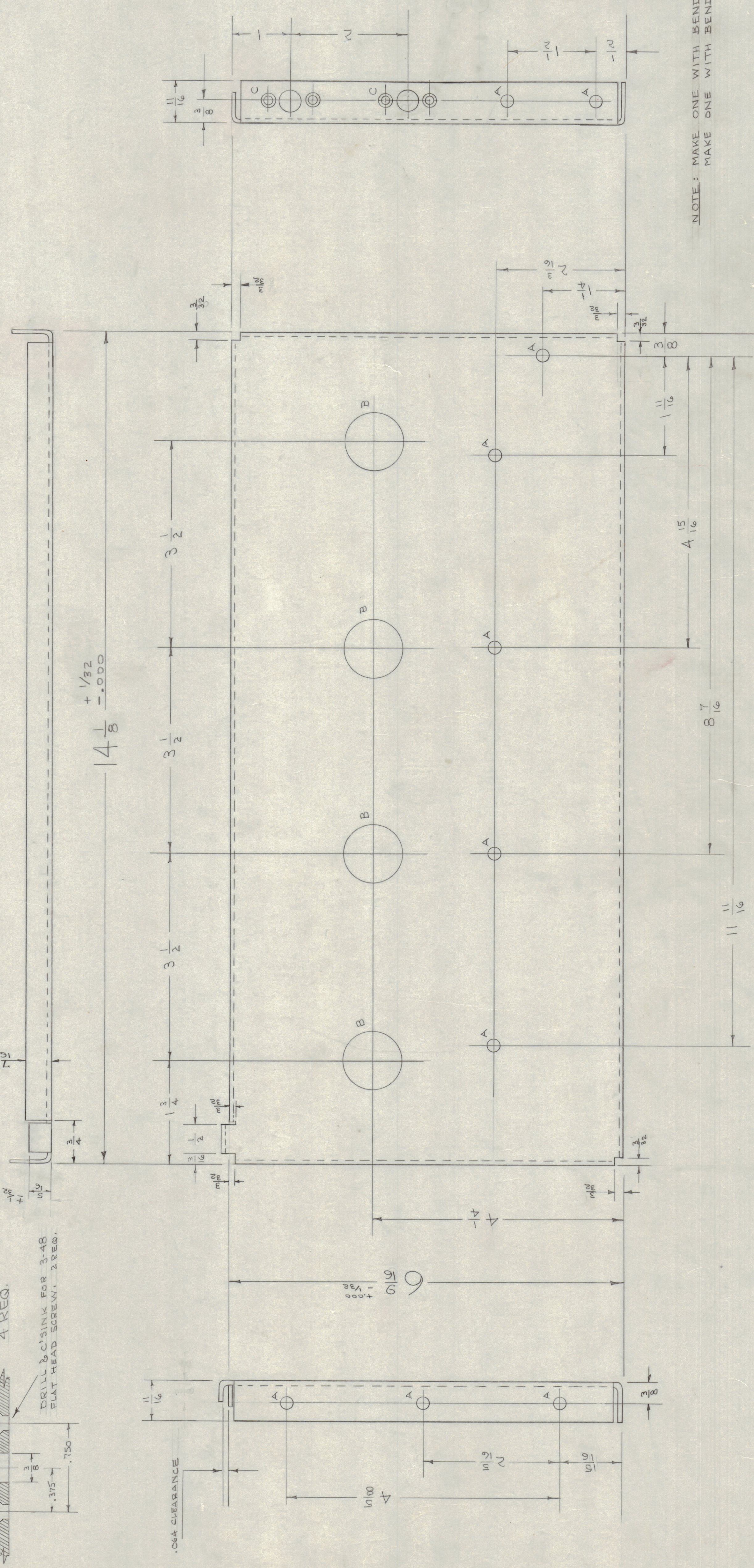
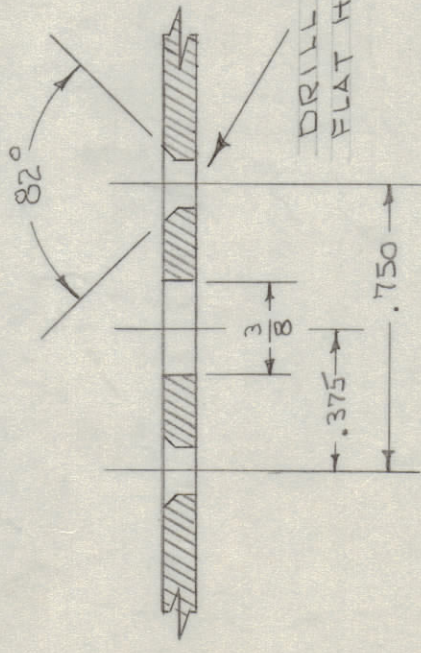

NOTICE TO PERSONS RECEIVING THIS DRAWING
 THE TECHNICAL MATERIEL CORPORATION claims
 proprietary right in the material disclosed herein.
 This drawing is issued in confidence for engineering
 information only and may not be reproduced or used
 to manufacture anything shown herein without per-
 mission from THE TECHNICAL MATERIEL CORPORA-
 TION to the user. This drawing is loaned for mutual
 assistance and is subject to recall at any time.
 Property of:
 THE TECHNICAL MATERIEL CORPORATION
 MAMARONECK, NEW YORK

METAL STAMP TMC PART NO.
 WITH LATEST REVISION LETTER,
 1/8 HIGH GOTHIC.

8	5	NTH6348BC6	NUT, HEX.
8	4	LW503 MRC	LOCKWASHER, SPLIT
8	3	SF50348BC4	SCREWS, MACHINE
4	2	FS-102-1	SPRING CLIP
1	1	DELETED	
P.C. ITEM		PART NO.	DESCRIPTION
.064			THE TECHNICAL MATERIEL CORP.
STOCK SIZE			MAMARONECK, NEW YORK
MATERIAL			SIDE PLATES
525-H32			RSD-2
TYPE & TEMPER			
HEAT TREAT. SPEC.			
S404 TRITITE D1			
FINISH & SPEC. NO.			

3	METAL STAMP NOTE ADD.	108.412522	MB
2	TITMS-387 DELETED	9/15/1001	ALB
1	5-404 TRITITE WAS	10/15/54	1
A	3/16 CORNERS WAS VA	10/15/54	1
ISSUE ITEM	CHANGED FROM	DATE	EN. APP.
SCALE: 1" = 1/2"			
DRILL BITTING COMMERCIAL STOCK SIZES AND MANUFACTURER TOLERANCES ARE NOT INCLUDED.			

SEE NOTE	RSD-2	170	10-13-54
MODEL	PROJECT NO.	DATE	
ASBY. NO.	10-13-54		
MS 387			