

REVISIONS						
ZONE	SYM	DESCRIPTION	DATE	E.M.N. NO.	DRAFT	CHKD APPD
X1		D, E, H, G HOLES & SLOT LOCATIONS ADDED	6-1-64	X1	A.M.	
X2		F-HOLE WAS 2 REQ., K-HOLE DELETED	6.5.64	X2	WPS	
Ø		ORIGINAL RELEASE FOR PRODUCTION	6/25/64	Ø	A.M.	
A		(3) J HOLES REVISED	1.4.65	13214	JTB	
E3	B	2.220 DIA. HOLE WAS 2 15/64 D. (METER HOLE)	2-10-65	13420	Shen	JTB

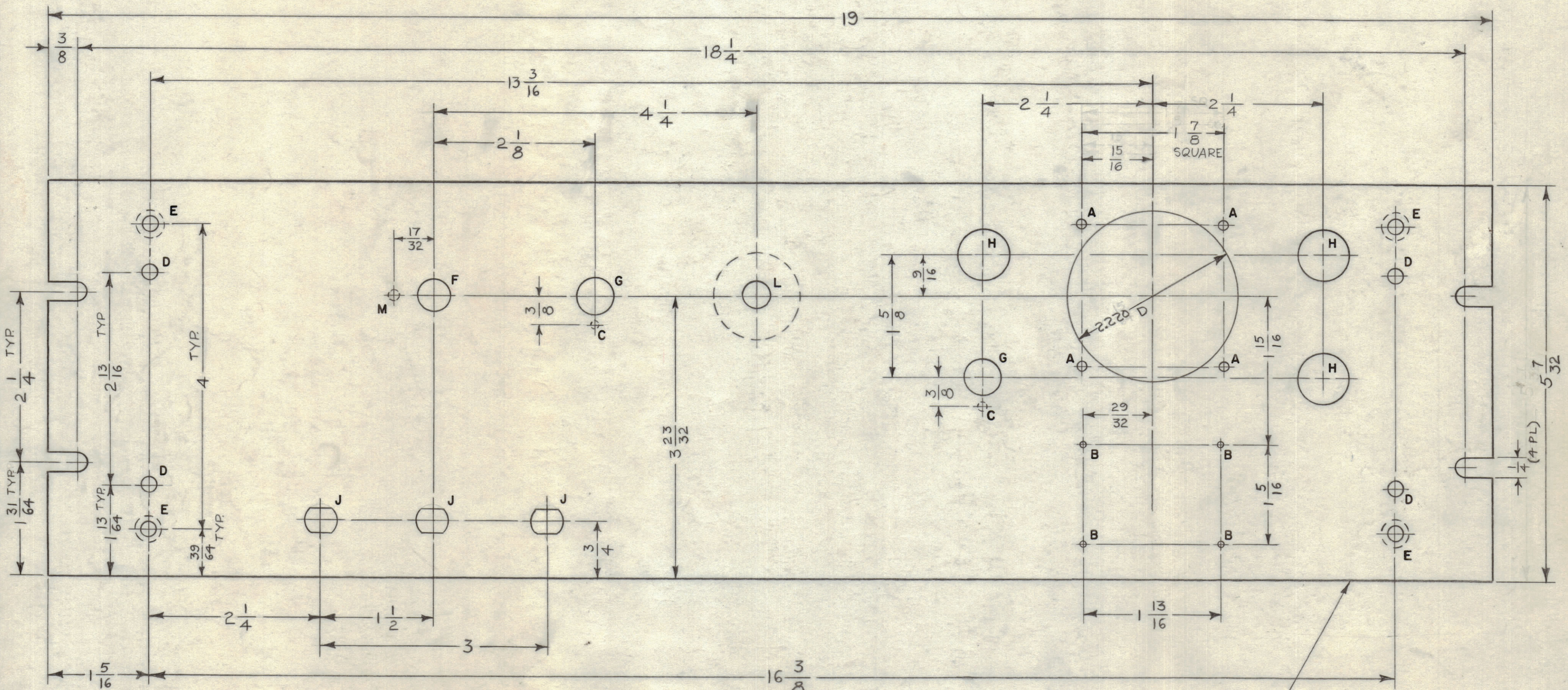

MACHINING:

1. MILL ALL EDGES.
2. HOLES MUST BE DRILLED, UNLESS OTHERWISE SPECIFIED.
3. LATERAL BOW OF PANEL MUST BE KEPT TO .031 TOLERANCE.
4. PANEL MUST BE FREE OF ALL MACHINING MARKS, GOUGES AND SCRATCHES. IF NECESSARY, SAND FRONT OF PANEL WITH NO. 120 GRIT SANDPAPER.

FINISH NOTES:

1. S404 - IRIDITE 14-2 AL-COAT.
2. S114 - ZINC CHROMATE PRIMER) FRONT AND
3. S115 - SMOOTH GRAY ENAMEL) EDGES ONLY

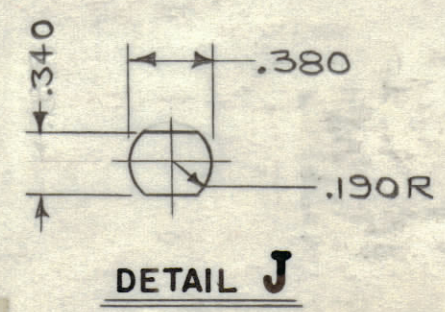

METAL STAMP TMC PART NO. 1/8 HIGH GOTHIC ON REAR OF PANEL, WITH LATEST REVISION LETTER.

LEGEND		
HOLE	DESCRIPTION	REQD
A	1/8 DIA	4
B	.076 DIA	4
C	1/8 DIA X 3/32 DEEP	2
D	13/64 DIA	4
E	13/64 DIA & CSINK 82° X .390 DIA	4
F	13/32 DIA	1
G	1/2 DIA	2
H	11/16 DIA	3
J	SEE DETAIL	3
L	3/8 DIA, C'BORE 1/8 X 3/32 DP	1
M	5/32 DIA X 3/32 DEEP	1

NOTES

1	CSS-2	
Q'TY./UNIT	MODEL USED ON	ASSY. NO.
SCALE 1:1	CODE A	
THE CONTENTS OF THIS DRAWING ARE THE EXCLUSIVE PROPERTY OF THE TECHNICAL MATERIEL CORP. ITS UNAUTHORIZED USE OR REPRODUCTION IN WHOLE OR IN PART IS STRICTLY FORBIDDEN.		

REF: LD 1442

REQ'D.	ITEM	PART NUMBER	DESCRIPTION	SYMBOL
M. GELLMAN LIST OF MATERIAL				
MATERIAL		3/16 THICK 2024-T3 ALUMINUM		
FINISH		SEE NOTES		
DRAWN		DATE 1-22-64		
CHECKED		DATE 6/24/64		
ELECT. DES.		DATE		
MECH. DES.		DATE		
UNLESS OTHERWISE SPECIFIED DIMENSIONS ARE IN INCHES AND INCLUDE CHEMICALLY APPLIED OR PLATED FINISHES		FINAL APPROVAL		
DECIMALS X ± .05 .XX ± .01 .XXX ± .005		FRACTIONS ± 1/64 ANGLES ± 0° 30'		DATE
		TOLERANCES		DATE
				DATE

MS 3708 B

MS 3708 B