

REVISIONS						
ZONE	SYM	DESCRIPTION	DATE	E.M.N. NO.	DRAFT	CHKD
X		EXPERIMENTAL RELEASE	8-21-64	X	SRG	
Ø		ORIGINAL RELEASE FOR PRODUCTION	8-31-64	Ø	-L	

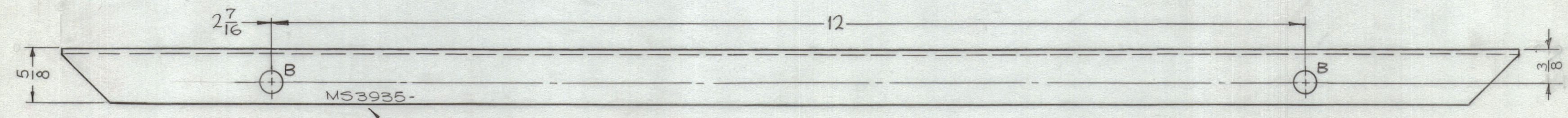
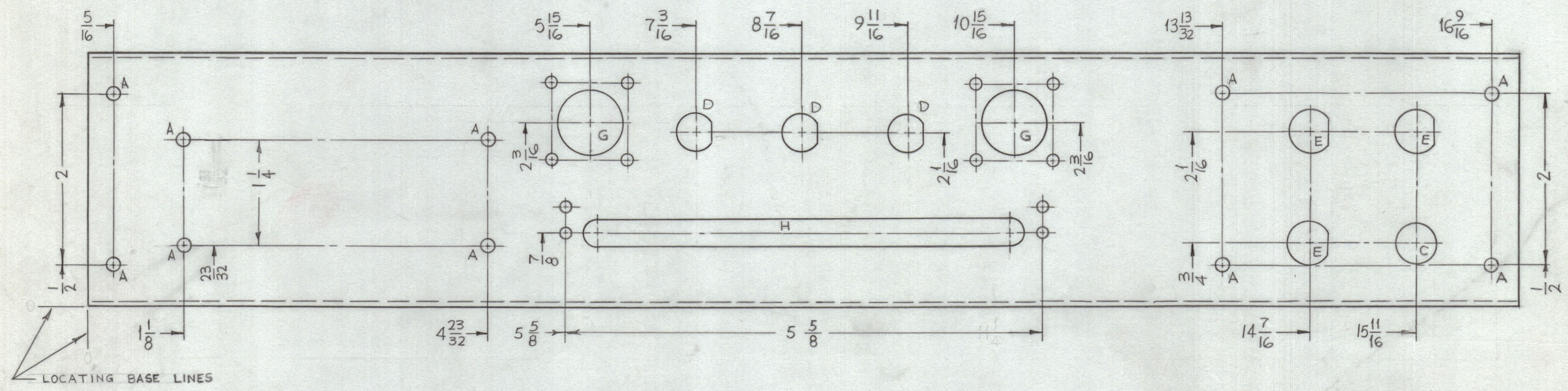
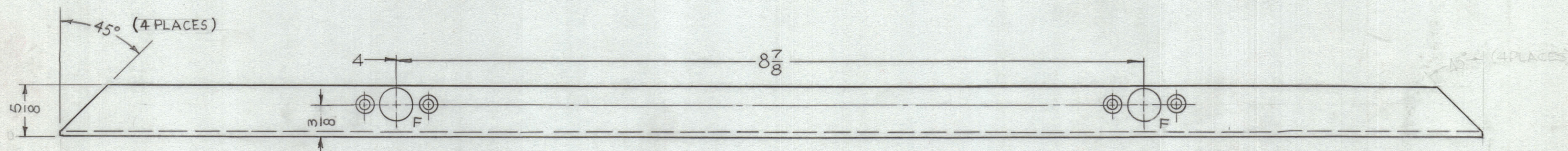

METAL STAMP TMC PART NO.
1/8 HIGH GOTHIC W/LATEST
REV. LETTER

HOLE	DESCRIPTION	REQ.
A	5/32 DIA.	10
B	1/4 DIA.	2
C	15/32 DIA.	1
D	SEE DETAIL	3
E	↑	3
F	↑	2
G	↓	2
H	SEE DETAIL	1

- UNLESS OTHERWISE SPECIFIED:
1. USE MATERIAL THICKNESS FOR MAXIMUM RADIUS ON ALL BENDS
 2. ALL ANGULAR BENDS 90 DEGREES
 3. REMOVE ALL BURRS AND SHARP EDGES

REF: LD1573

REQ'D.	ITEM	PART NUMBER	DESCRIPTION	SYMBOL
M.GELLMAN LIST OF MATERIAL				
MATERIAL		THE TECHNICAL MATERIEL CORP.		
.081 THICK ALUMINUM		MAMARONECK, NEW YORK		
5052-H32		TITLE		
FINISH		S404 YELLOW IRIDITE		
TITLE		PANEL, REAR		
DRAWN		SRG	DATE	FINAL APPROVAL
CHECKED		SRG	8-21-64	KL
ELECT. DES.		SRG	DATE	9-1-64
MECH. DES.		SRG	DATE	MS3935
DECIMALS		FRACTIONS		SHEET
.X ± .05		± 1/64		Ø
.XX ± .01		ANGLES		REV. LTR.
.XXX ± .005		± 0° 30'		

Q'TY./UNIT	MODEL USED ON	ASS'Y. NO.
1	LFC-A-1	
SCALE	CODE	
1:1	A	

NOTES

THE CONTENTS OF THIS DRAWING ARE THE EXCLUSIVE PROPERTY OF THE TECHNICAL MATERIEL CORP. ITS UNAUTHORIZED USE OR REPRODUCTION IN WHOLE OR IN PART IS STRICTLY FORBIDDEN.

MS3935
Ø