

REVISIONS							
ZONE	SYM	DESCRIPTION	DATE	E.M.N. NO.	DRAFT	CHKD	APPD
	X4	REDRAWN, NO CHANGES	1/12/65	X4	JL		
C6	X5	(1) "E" DETAIL DELETED	1-19-65	X5	J.M.	J.M.	W.J.
	Q	ORIGINAL RELEASE FOR PRODUCTION	1-20-65		J.M.	J.M.	
E3,4	A	2 "F" HOLES RELOC.	3/29/65	13635	J.L.	J.L.	J.L.

HOLE LEGEND		
HOLE	DESCRIPTION	REQ'D
A	.221-.224 DIA	8
B	SEE DETAIL	3
C	" "	1
D	" "	2
E	DELETED	-
F	1/164 DIA	2

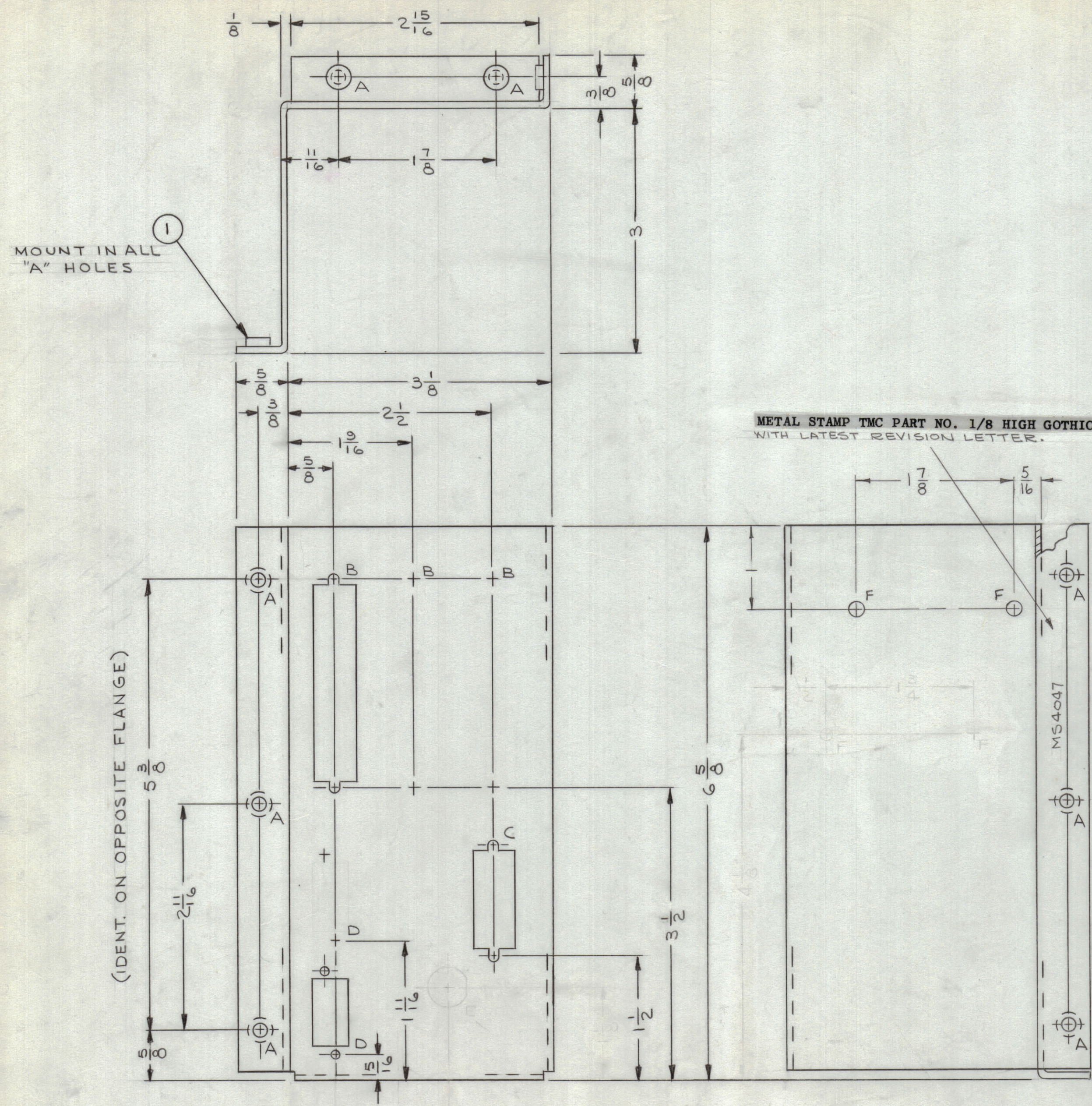

METAL STAMP TMC PART NO. 1/8 HIGH GOTHIC.
WITH LATEST REVISION LETTER.

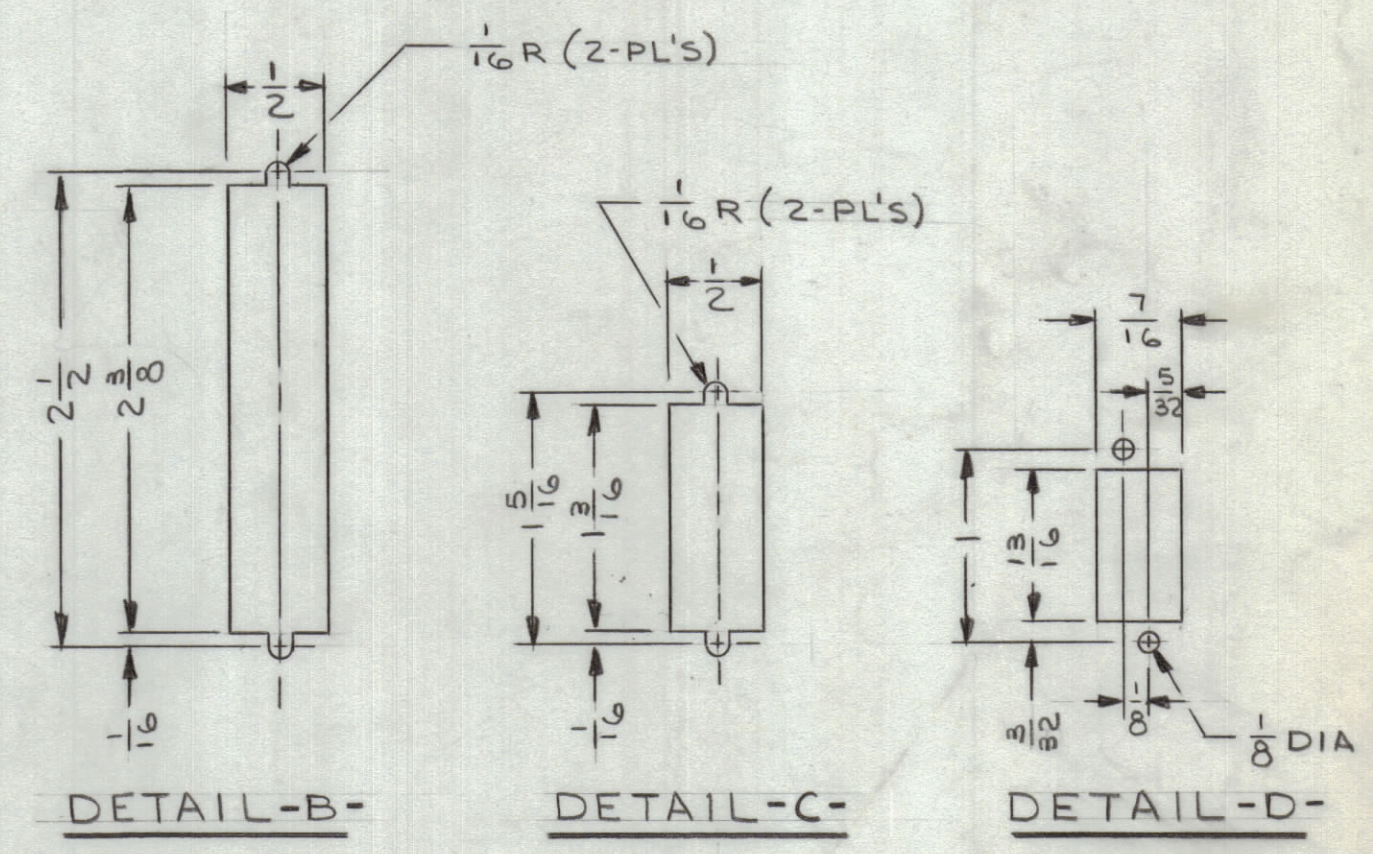

(IDENT. ON OPPOSITE FLANGE)

- UNLESS OTHERWISE SPECIFIED:
1. USE MATERIAL THICKNESS FOR MAXIMUM RADIUS ON ALL BENDS
 2. ALL ANGULAR BENDS 90 DEGREES
 3. REMOVE ALL BURRS AND SHARP EDGES
 4. MOUNT INSERTS AFTER FINISHING

NOTES

1	RTMU-1	A4052
Q'TY./UNIT	MODEL USED ON	ASS'Y. NO.
SCALE 1:1	CODE A	

REF: LD1634

8	1	NT-129-832-4	NUT, PLAIN SPLINE TYPE	A
REQ'D.	ITEM	PART NUMBER	DESCRIPTION	SYMBOL
LIST OF MATERIAL				
MATERIAL .081 THK ALUMINUM 5052-H32			THE TECHNICAL MATERIEL CORP. MAMARONECK, NEW YORK	
FINISH YELLOW IRIDITE PER S4.04			TITLE BRACKET, MTG, CONNECTOR	
UNLESS OTHERWISE SPECIFIED DIMENSIONS ARE IN INCHES AND INCLUDE CHEMICALLY APPLIED OR PLATED FINISHES			DRAWN J. LESHINSKI	DATE 1/12/65
DECIMALS .X ± .05 .XX ± .01 .XXX ± .005			CHECKED @	DATE 1-18-65
FRACTIONS ± 1/64 ANGLES ± 0° 30'			ELECT. DES. W. JORDAN	DATE 1/19/65
TOLERANCES			MECH. DES. W. JORDAN	DATE 1/19/65
THE CONTENTS OF THIS DRAWING ARE THE EXCLUSIVE PROPERTY OF THE TECHNICAL MATERIEL CORP. ITS UNAUTHORIZED USE OR REPRODUCTION IN WHOLE OR IN PART IS STRICTLY FORBIDDEN.			FINAL APPROVAL RSC	
			DATE	
			SHEET	
			REV. LTR.	

MS4047A