

REVISIONS						
ZONE	SYM	DESCRIPTION	DATE	E.M.N. NO.	DRAFT	CHKD
X		EXP. RELEASE	10-12-64		G.D.L.	
Ø		ORIGINAL RELEASE FOR PRODUCTION	10-14-64		AB	

HOLE	DESCRIPTION	REQ.
A	1/8 DIA.	4
B	11/64 DIA.	6
C	.070 DIA	4
D	3/8 DIA	2

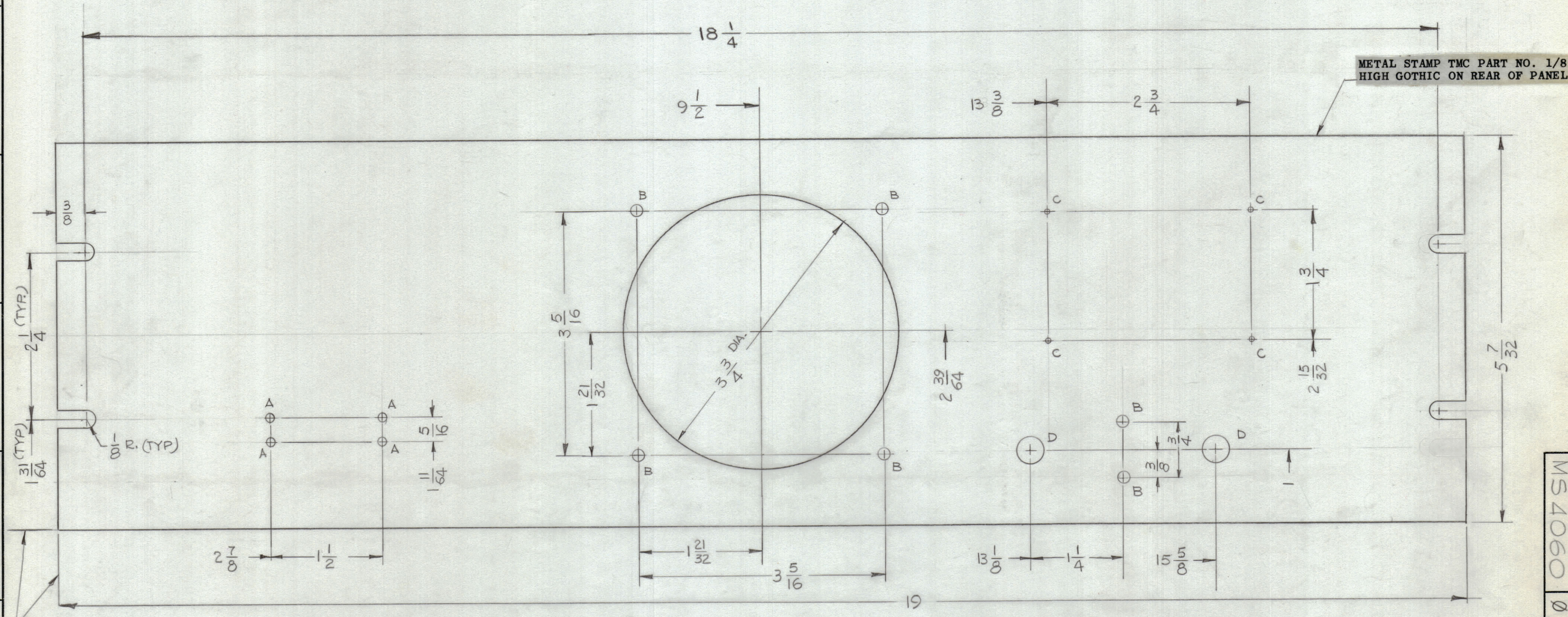

LOCATING BASE LINES

- MACHINING:**
1. MILL ALL EDGES.
 2. HOLES MUST BE DRILLED, UNLESS OTHERWISE SPECIFIED.
 3. LATERAL BOW OF PANEL MUST BE KEPT TO .031 TOLERANCE.
 4. PANEL MUST BE FREE OF ALL MACHINING MARKS, GOUGES AND SCRATCHES. IF NECESSARY, SAND FRONT OF PANEL WITH NO. 120 GRIT SANDPAPER.

- FINISH NOTES:**
1. S404 - IRIDITE 14-2 AL-COAT.
 2. S114 - ZINC CHROMATE PRIMER) FRONT AND
 3. S115 - SMOOTH GRAY ENAMEL) EDGES ONLY

NOTES

1	HSS-3A	
Q'TY./UNIT	MODEL USED ON	ASS'Y. NO.
SCALE 1:1	CODE A	
THE CONTENTS OF THIS DRAWING ARE THE EXCLUSIVE PROPERTY OF THE TECHNICAL MATERIEL CORP. ITS UNAUTHORIZED USE OR REPRODUCTION IN WHOLE OR IN PART IS STRICTLY FORBIDDEN.		

REF: LD 1628

REQ'D.	ITEM	PART NUMBER	DESCRIPTION	SYMBOL
LIST OF MATERIAL				
MATERIAL		3/16 THK ALUMINUM 2024-T3	THE TECHNICAL MATERIEL CORP. MAMARONECK, NEW YORK	
FINISH		SEE NOTES	TITLE PANEL, FRONT	
UNLESS OTHERWISE SPECIFIED DIMENSIONS ARE IN INCHES AND INCLUDE CHEMICALLY APPLIED OR PLATED FINISHES		DRAWN G.D.L.	DATE 10-12-64	FINAL APPROVAL [Signature]
DECIMALS .X ± .05 .XX ± .01 .XXX ± .005		CHECKED @	DATE 10-13-64	DATE
FRACTIONS ± 1/64 ANGLES ± 0° 30'		ELECT. DES.	DATE	MS4060
TOLERANCES		MECH. DES. [Signature]	DATE 10/14/64	Ø
			SHEET	REV. LTR.

MS4060