

REVISIONS					
ZONE	LTR	DESCRIPTION	DATE	E.M.N.NO	DRAFT CHKD APPD

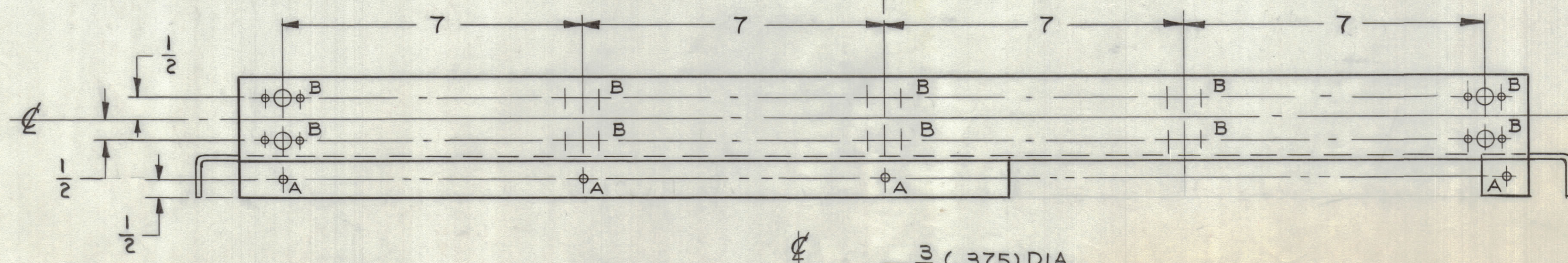

"A" HOLES NO.16 DR(.177) DIA 14 REQ

DETAIL CLUSTER "B" HOLES 10 REQ

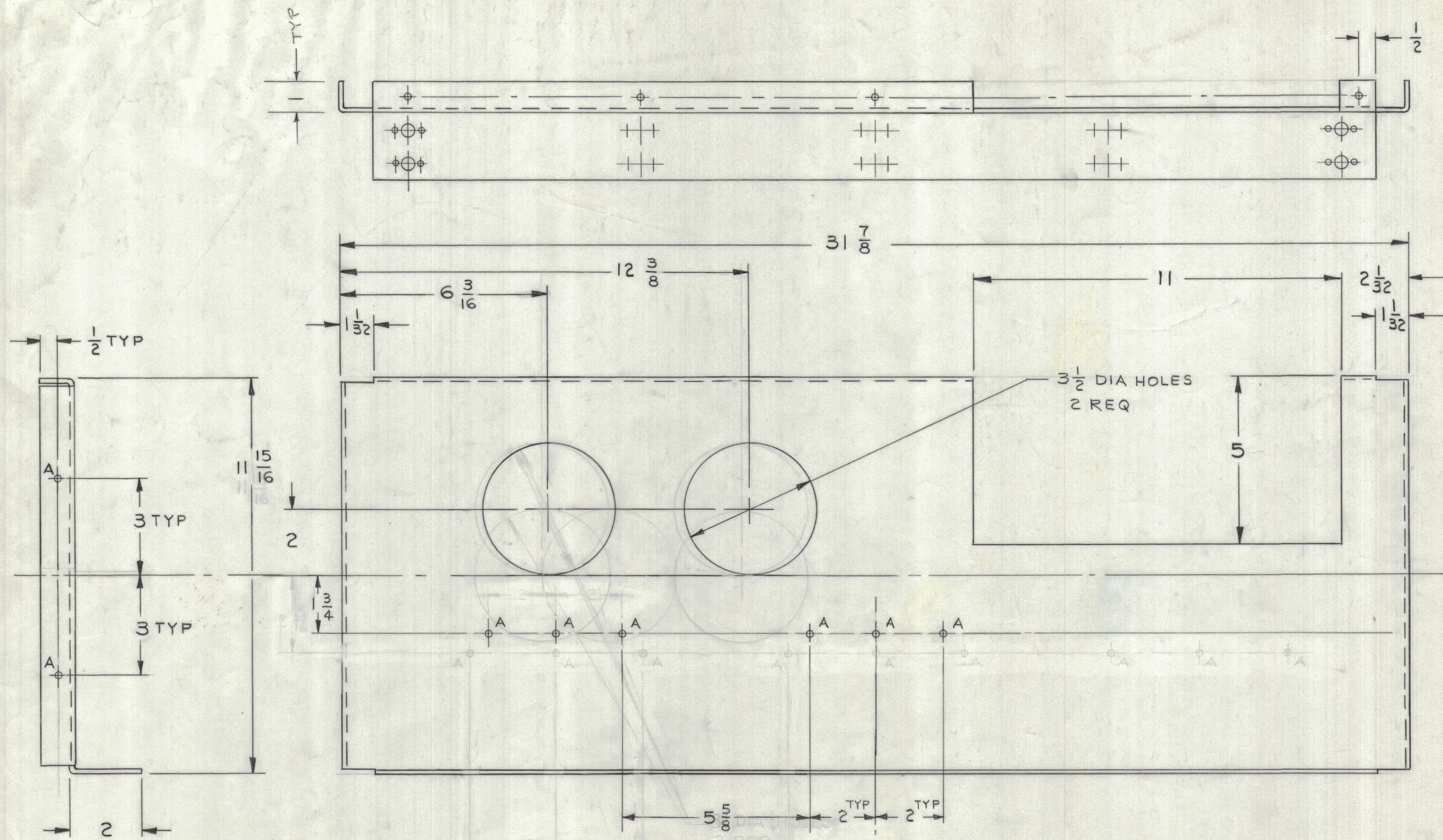
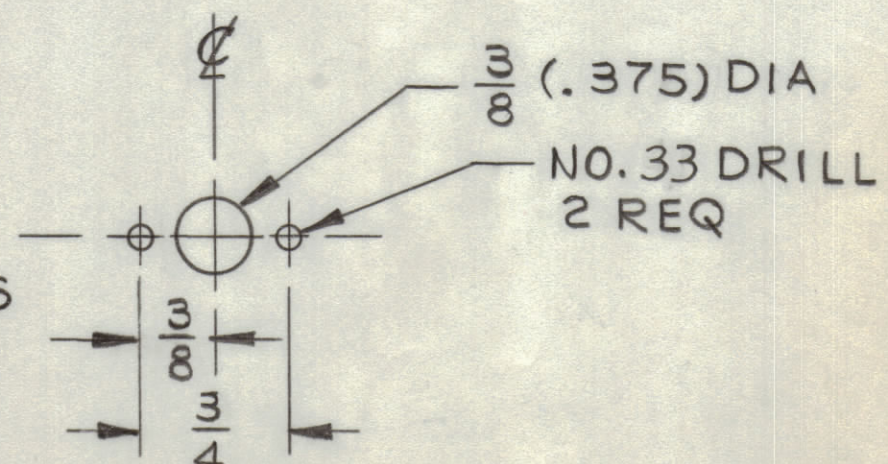

NOTE: .064 MAX BEND RADIUS

- UNLESS OTHERWISE SPECIFIED:
1. USE MATERIAL THICKNESS FOR MAXIMUM RADIUS ON ALL BENDS
 2. ALL ANGULAR BENDS 90 DEGREES
 3. REMOVE ALL BURRS AND SHARP EDGES
 4. MOUNT INSERTS AFTER FINISHING

1	PDP-1 27	A8008
QTY / UNIT	MODEL USED ON	ASS'Y NO.
APPLICATION		
CODE		

UNLESS OTHERWISE SPECIFIED DIMENSIONS ARE IN INCHES AND INCLUDE CHEMICALLY APPLIED OR PLATED FINISHES

TOLERANCES ON

DECIMALS	FRACTIONS
.X ± .05	± 1/64
.XX ± .01	ANGLES
.XXX ± .005	± 0° -30'

MATERIAL .064 THK 5052-H32 ALUM
FINISH S-404 YEL IRIDITE

QTY. REQ.	ITEM	PART NO.	DESCRIPTION	SYMBOL
LIST OF MATERIAL				
THE TECHNICAL MATERIEL CORP. MAMARONECK, NEW YORK				
BREAKER PANEL DIVIDER LEFT HAND UNIT-27				
SIZE	CODE IDENT.NO.	DWG NO.	ISSUE	
D	82679	MS 8024	φ	
SCALE 1/2			SHEET	OF

MS 8024