

REVISIONS						
ZONE	LTR	DESCRIPTION	DATE	E.M.N.NO	DRAFT	CHKD
X		DWG. No WAS 40M12D7063	8-10-67		J. McM	
Ø		ORIGINAL RELEASE FOR PRODUCTION	9/15/68			

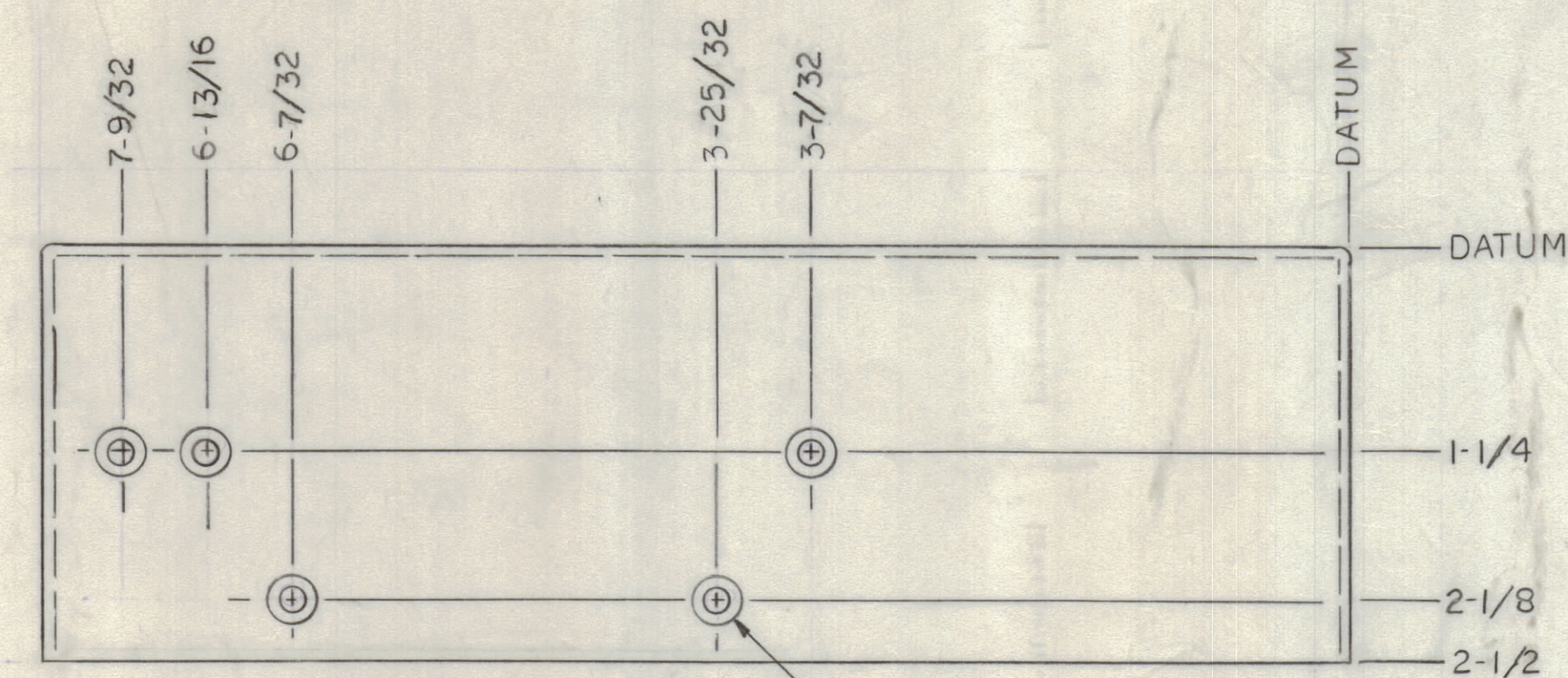
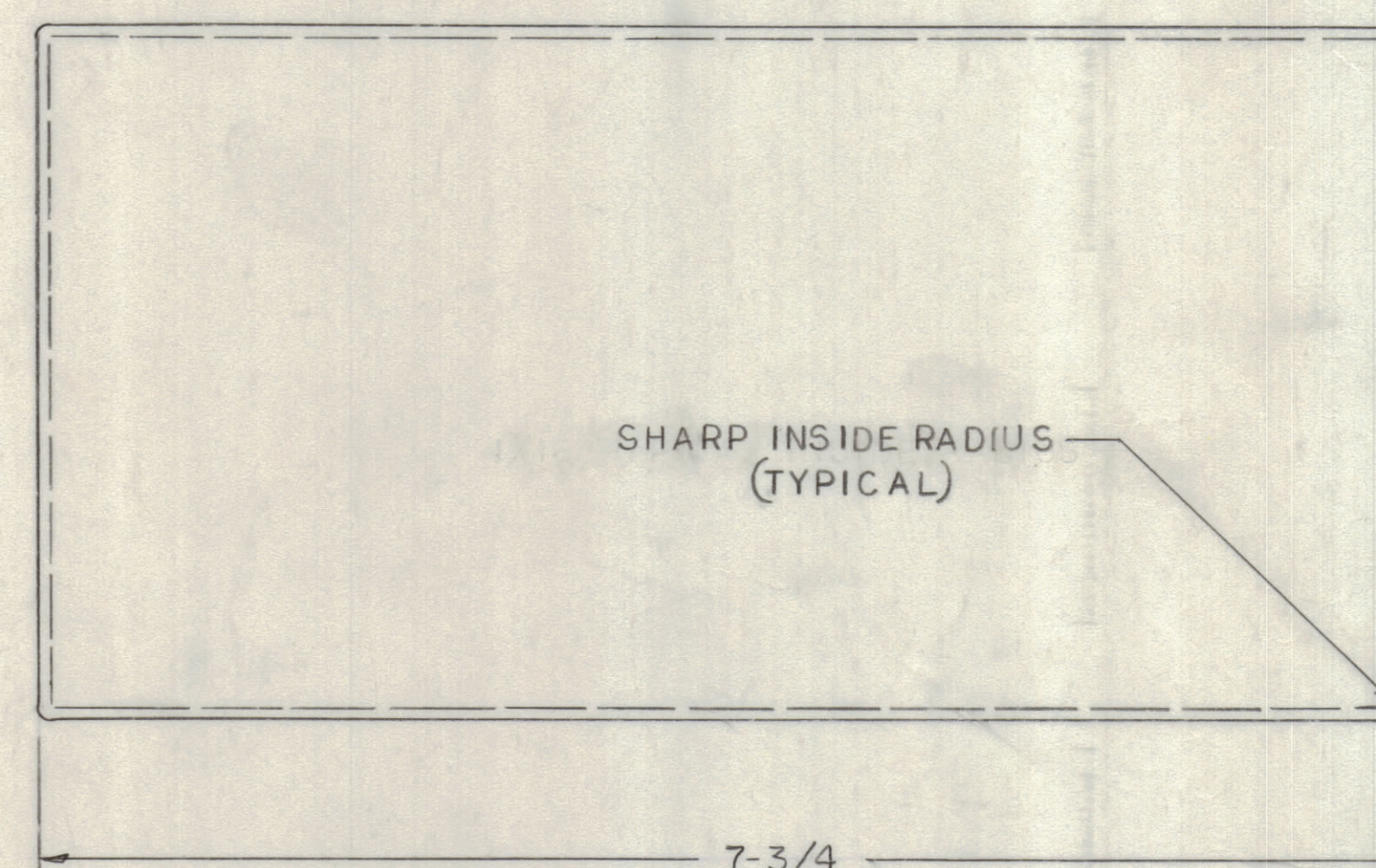
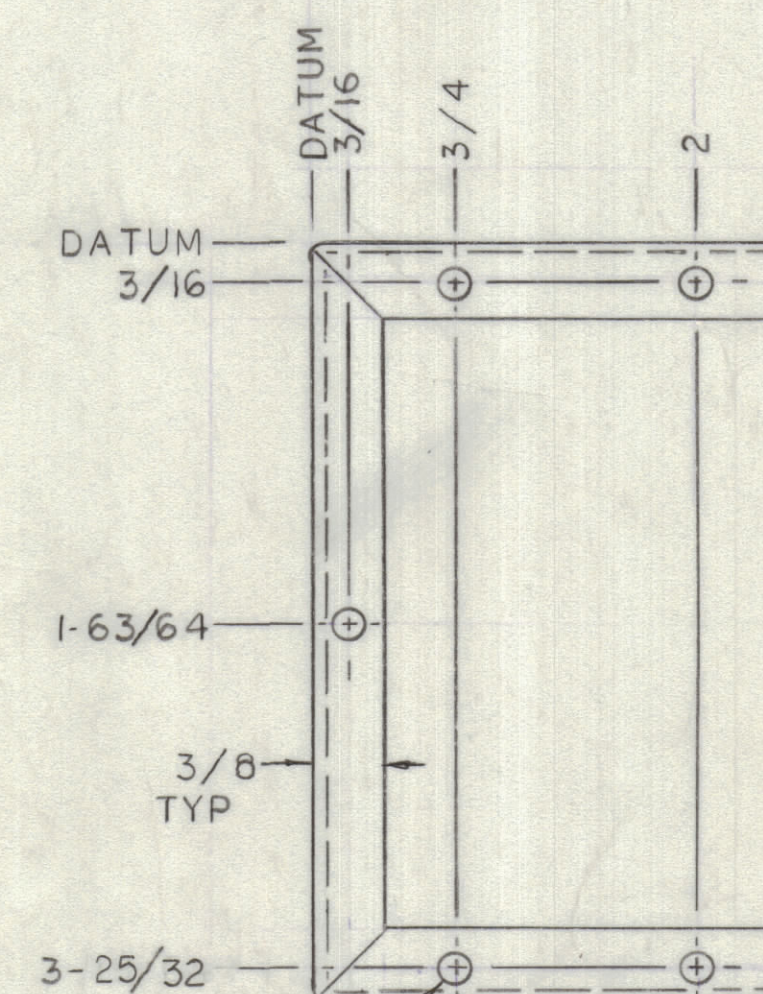
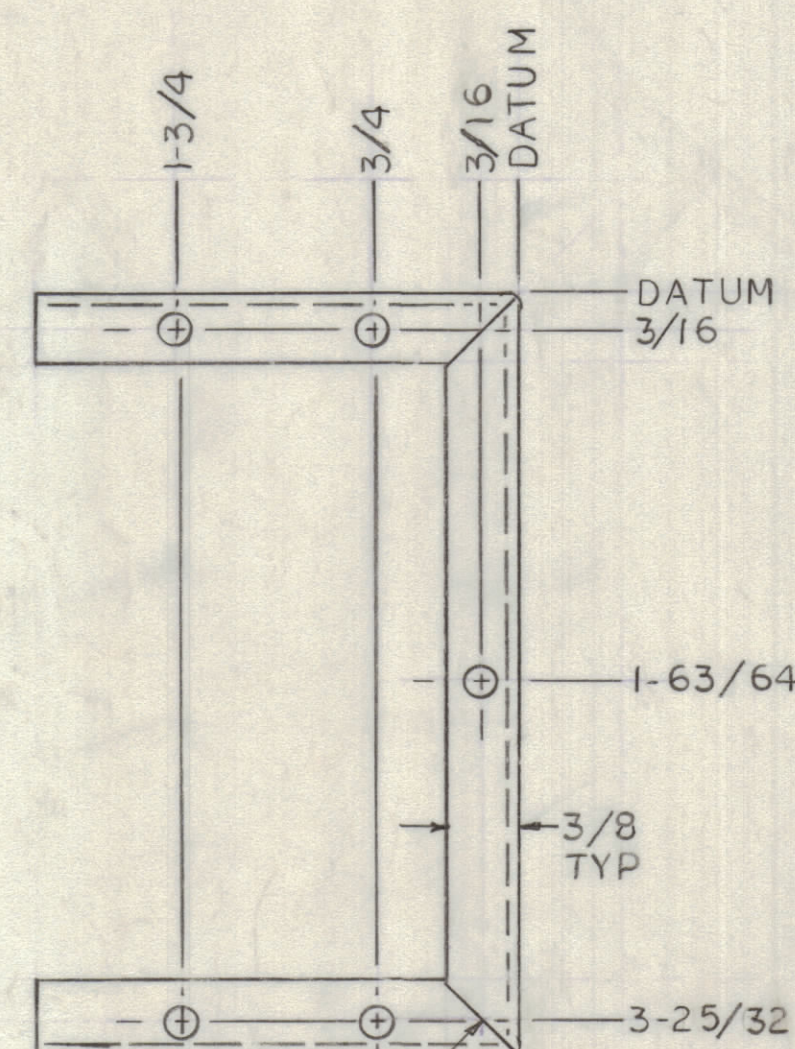
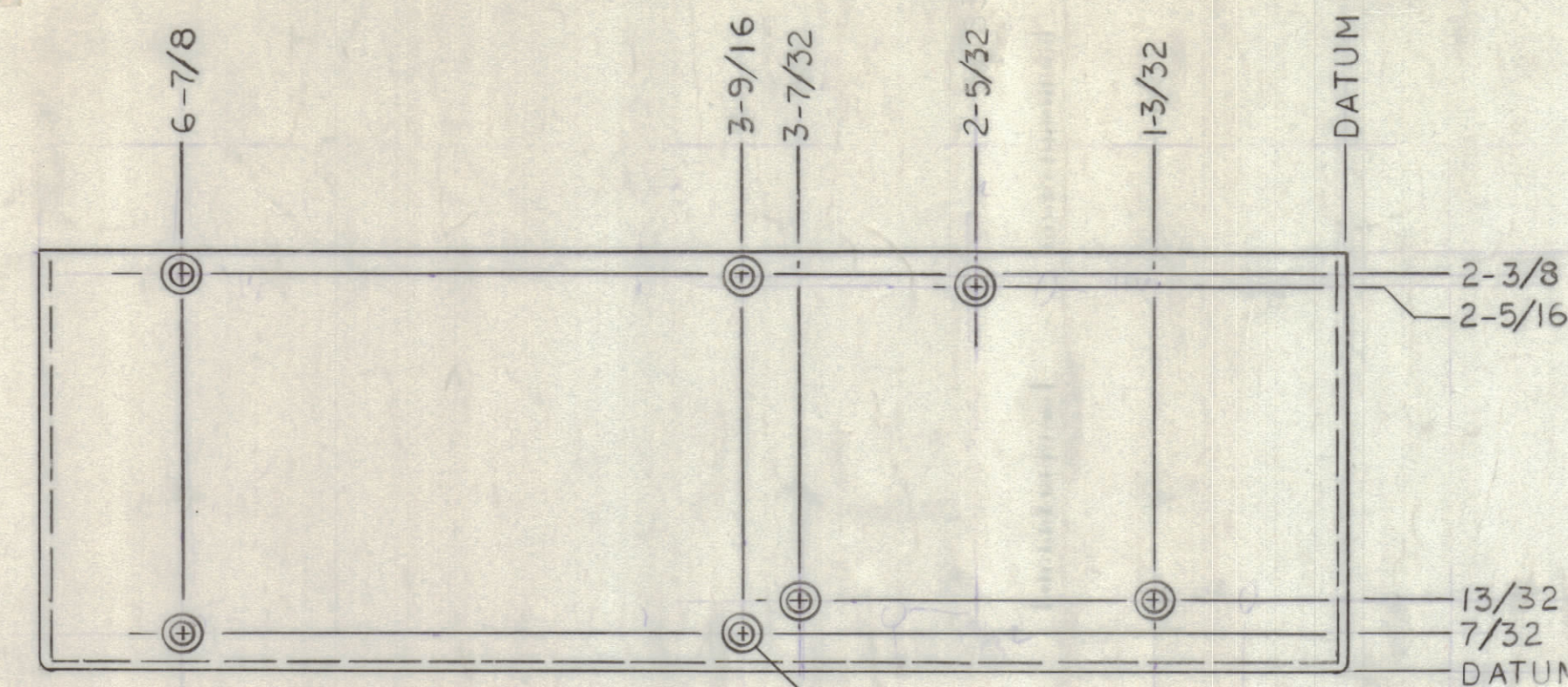

ITEM -3

1	SPT-3KVHF	AP-138
QTY / UNIT	MODEL USED ON	ASS'Y NO.
APPLICATION A8054		
CODE		
NOTICE TO PERSONS RECEIVING THIS DRAWING		
THE TECHNICAL MATERIEL CORPORATION claims proprietary right in the material disclosed hereon. This drawing is issued in confidence for engineering information only and may not be reproduced or used to manufacture anything shown hereon without permission from THE TECHNICAL MATERIEL CORPORATION to the user. This drawing is loaned for mutual assistance and is subject to recall at any time.		

UNLESS OTHERWISE SPECIFIED DIMENSIONS ARE IN INCHES AND INCLUDE CHEMICALLY APPLIED OR PLATED FINISHES	
DECIMALS .X ± .05 .XX ± .01 .XXX ± .005	FRACTIONS ± 1/64 ANGLES ± 0° -30'
TOLERANCES ON	
MATERIAL .062 THICK 6061-T4 ALUM ALLOY	
FINISH CAUSTIC ETCH AND GOLD IRIDITE	

QTY. REQ.	ITEM	PART NO.	DESCRIPTION	SYMBOL
LIST OF MATERIAL				
THE TECHNICAL MATERIEL CORP. MAMARONECK, NEW YORK				
CHASSIS PSD-R-12-1				
SIZE	CODE IDENT. NO.	DWG NO.	ISSUE	
D	82679	40MS8345	Ø	
SCALE 1:1				SHEET 1 OF 2