

REVISIONS							
ZONE	SYM	DESCRIPTION	DATE	E.M.N. NO.	DRAFT	CHKD	APPD
	0	ORIGINAL RELEASE FOR PRODUCTION	3-2-64				

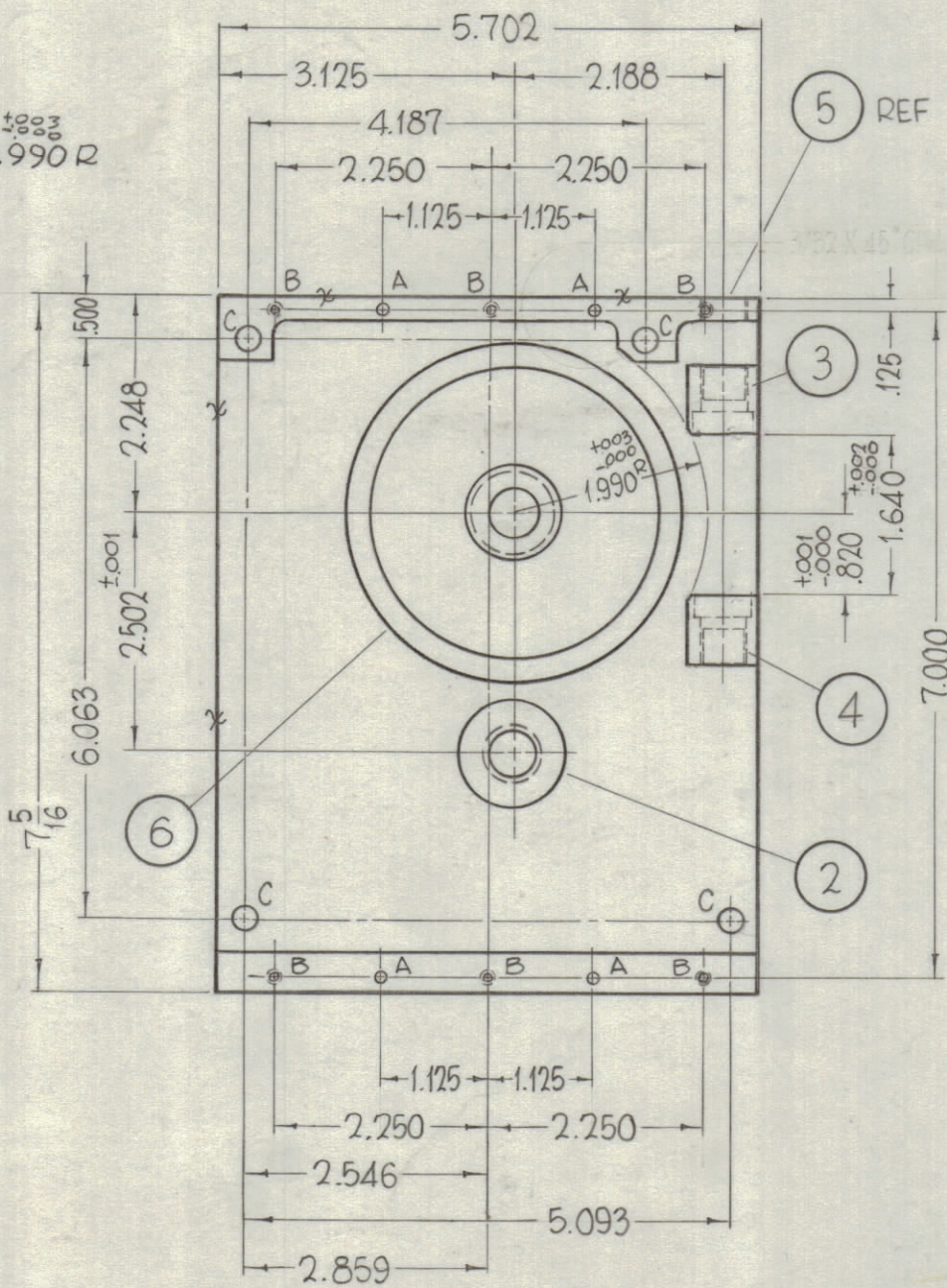
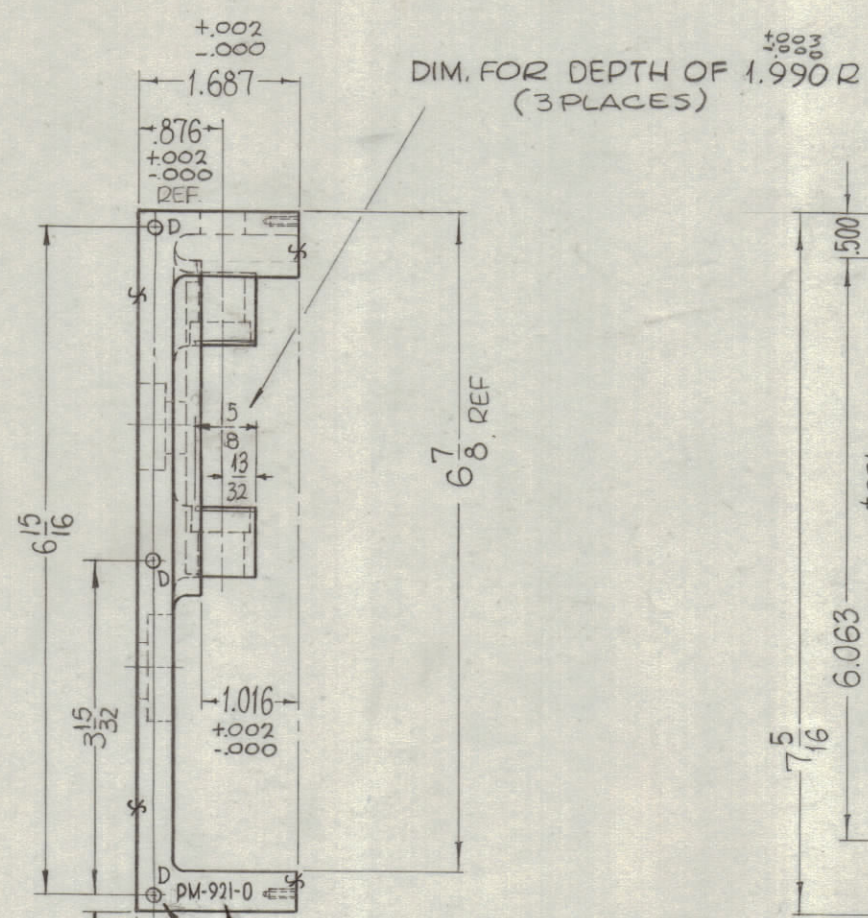
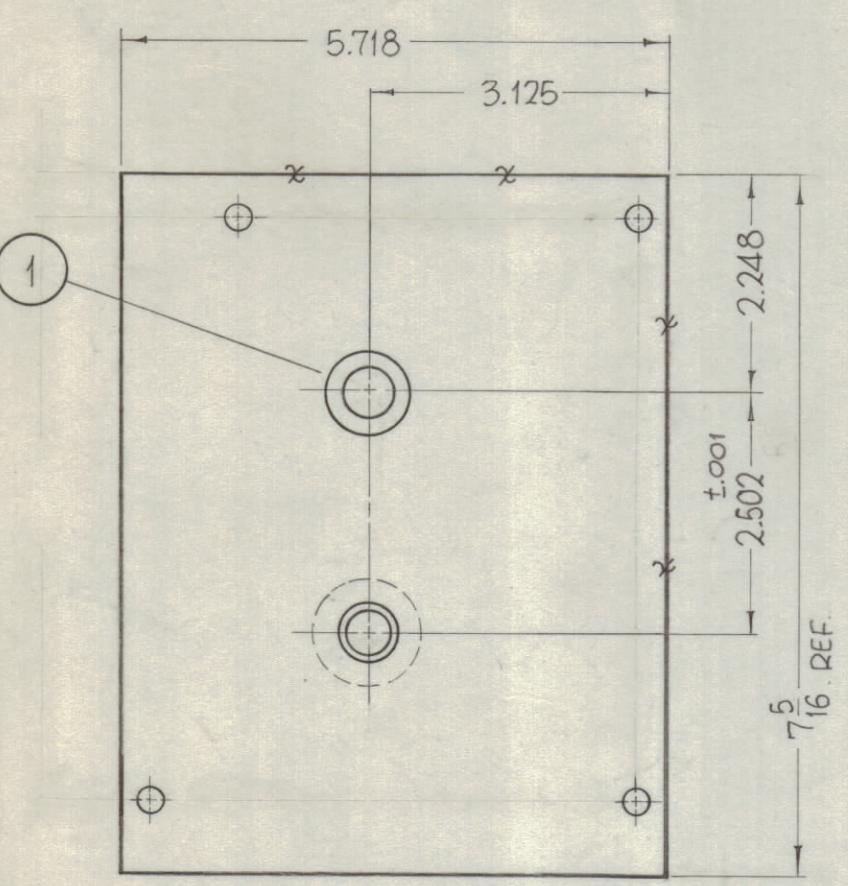
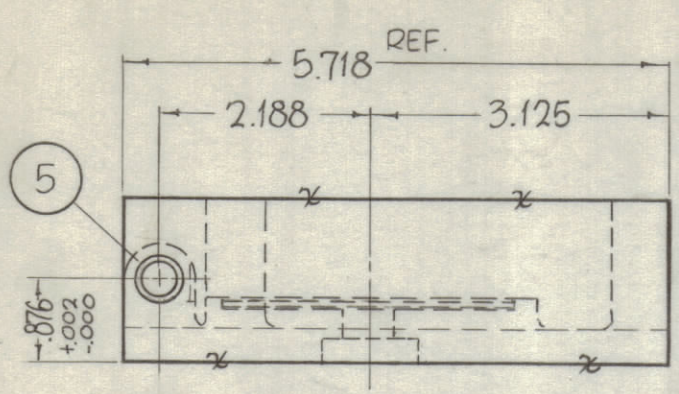

HOLES	REQ.
† A - .156 DIA. X 1/4 DEEP	4
B - DRILL & TAP 4-40 X 5/16 DEEP	6
C - 5/16 DIA. THRU	4
D - .089 DIA. X 1/4 DEEP	6

UNLESS OTHERWISE SPECIFIED
 FINISH - S404-IRIDITE, 14-2, AL-COAT.
 ALL FINISHED SURFACES SHOWN (X) SHALL BE A CLASS 16, ($\sqrt{16}$) FINISH.
 * ALL BEARINGS TO BE WRINGING FIT (CLASS-5), INSERTED AFTER MACHINING AND IRIDITING.
 † TO BE DRILLED AND PINNED UPON ASSY.

METAL STAMP TMC PART NO. 1/8 HIGH GOTHIC.

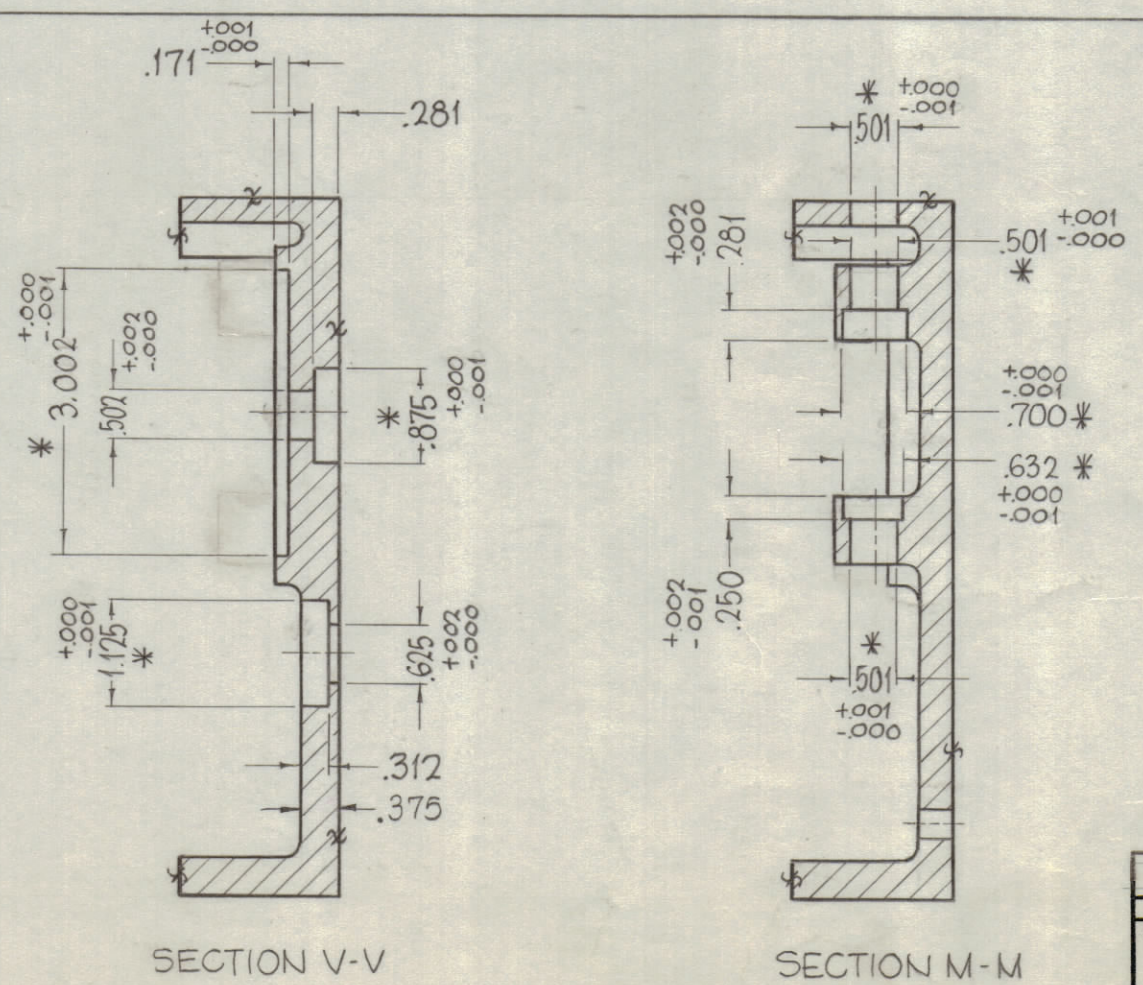

REF-CASTING, TMC NO. CS-128

*	1	6	BB-106-18	BEARING, THRUST	
*	1	5	BB-123-24	BEARING, CYLIN. OIL IMPREG.	
*	1	4	BB-123-19	BEARING, CYLIN. OIL IMPREG.	
*	1	3	BB-123-14	BEARING, CYLIN. OIL IMPREG.	
*	1	2	BB-120-3	BEARING, RACE	
*	1	1	BB-120-2	BEARING, RACE	

REQ'D.	ITEM	PART NUMBER	DESCRIPTION	SYMBOL
F. BUDETTI LIST OF MATERIAL				
MATERIAL			THE TECHNICAL MATERIEL CORP. MAMARONECK, NEW YORK	
FINISH			TITLE	
SEE NOTES			MACHINING, CAPACITOR GEAR BOX (TUNE)	
DRAWN		DATE	FINAL APPROVAL	
John C. Biele		6/12/63	RDE	
CHECKED		DATE	DATE	
AA 908		3-7-64	3-30-64	
ELECT. DES.		DATE	DATE	
MECH. DES.		DATE	DATE	
			PM-921	
			0	
			SHEET	
			REV. LTR.	

1	GPT-200K (AX-395)	A-3236
Q'TY/UNIT	MODEL USED ON	ASS'Y. NO.
SCALE	CODE	
1/2" = 1"	A	

THE CONTENTS OF THIS DRAWING ARE THE EXCLUSIVE PROPERTY OF THE TECHNICAL MATERIEL CORP. ITS UNAUTHORIZED USE OR REPRODUCTION IN WHOLE OR IN PART IS STRICTLY FORBIDDEN.

UNLESS OTHERWISE SPECIFIED DIMENSIONS ARE IN INCHES AND INCLUDE CHEMICALLY APPLIED OR PLATED FINISHES

DECIMALS .X ± .05 .XX ± .01 .XXX ± .005 FRACTIONS ± 1/64 ANGLES ± 0° 30'

PM-921 0