

IF IT IS FOUND DESIRABLE TO CHANGE ANY TOLERANCE OR OTHER DETAIL SPECIFIED ON THIS DRAWING NOTIFY THE PURCHASER PROMPTLY.

PO-102 D

MAXIMUM ALLOWABLE TOLERANCES HAVE BEEN DETERMINED AND DEVIATIONS WILL BE CAUSE FOR REJECTION. REMOVE ALL BURRS AND SHARP EDGES

Req. Per. UNIT	USED ON			
	MODEL	PROJECT NO.	ASS'Y. NO.	DATE
1	XFK		A-641	3/15/52
2	RTF-2	F/P		11-5-58

TO BE SUPPLIED BY MFR.  
 2 HEADLESS SET SCREWS 6-32 X 3/16 LONG (HEX. SOCKET HEAD)  
 TMC EQUIV. AN565DGH3 (HEADLESS SET SCREWS)

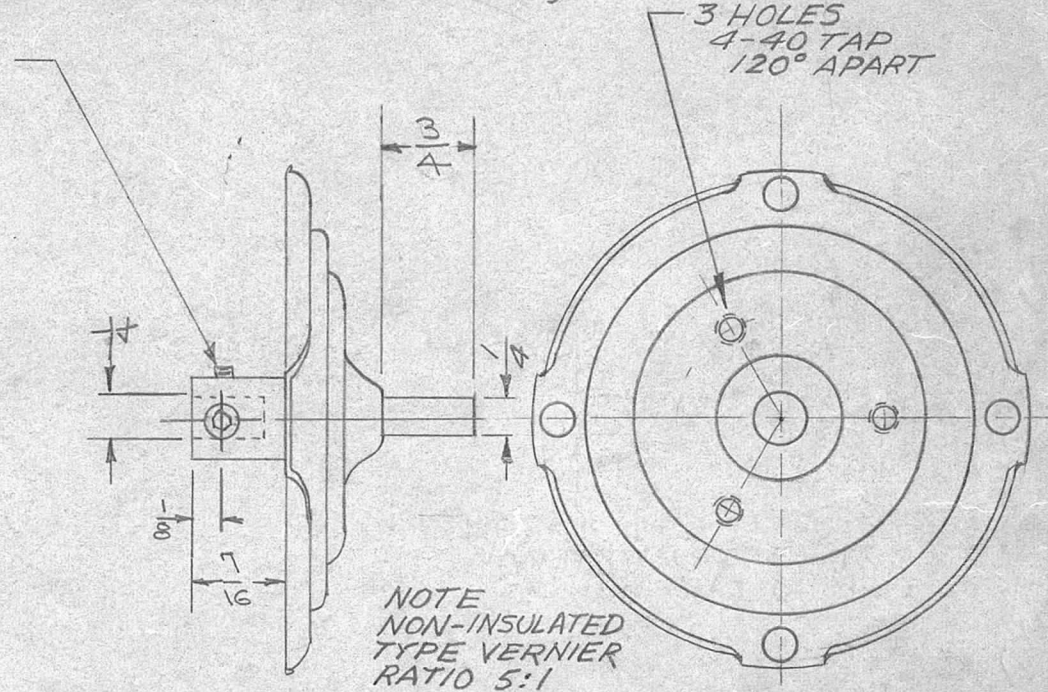
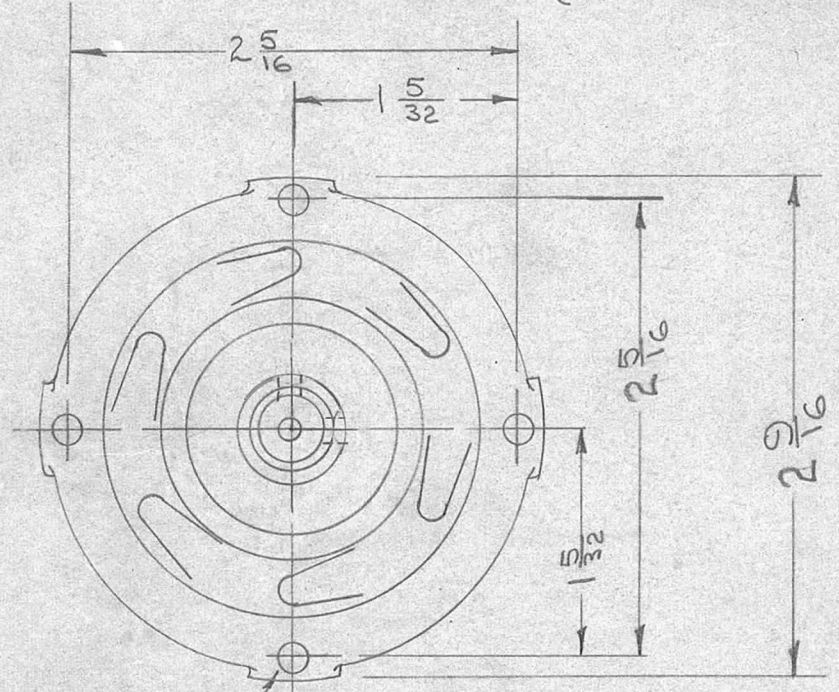

NOTE:  $\frac{5}{32}$  D 4 HOLES  
 TORQUE: 6 IN. OZ TO 32 IN. OZ

REF: NATIONAL CO. TYPE AVD.

ISSUE	ITEM	CHANGED FROM	DATE	CN. NO.	DRAFTS	CHECKER	ENG. APP.
D	1	NOTE ADDED	11/8/52	10366			
C	1	END VIEW ADDED	8/24/51	5492	wh	RL	LG
B	2	SET SCREW NOTE ADDED	12/20/56	2	JAC	JAC	W
	1	3/4 WAS 15/16					
A	1	DETAILS ADDED	10/22/53	1	JAC	LG	W

REQ.	ITEM	PART NO.	DESCRIPTION	SYMBOL
STOCK SIZE			THE TECHNICAL MATERIEL CORP.	
			MAMARONECK, NEW YORK	
			DRIVE, DIAL	
MATERIAL		WEIGHT PER PC.		
TYPE & TEMPER		DRAWN: <i>JAC</i> ELEC. DES. APP.: <i>A. J. J.</i> MECH. DES. APP.: <i>W</i>		
HEAT TREAT. SPEC.		15 10-22-53 CHECKED: <i>W</i> FINAL APPROVAL: <i>W</i>		
FINISH & SPEC. NO.		PO-102 D		

TOLERANCES	SCALE
ALL OTHERS DEC. DIM. $\pm$ FRAC. DIM. $\pm$ ANGULAR DIM. $\pm$	DRILL, PUNCH, COMMERCIAL STOCK SIZES AND MANUFACTURERS TOLERANCES ARE NOT INCLUDED.