

REVISIONS							
ZONE	SYM	DESCRIPTION	DATE	E.M.N. NO.	DRAFT	CHKD	APPD
A		ITEM 3, MS 576 & ITEMS DEL - PICT. UPDATED CHANGE ITEM 4 & 2 ITEMS	4-4-64	22051	GDL		

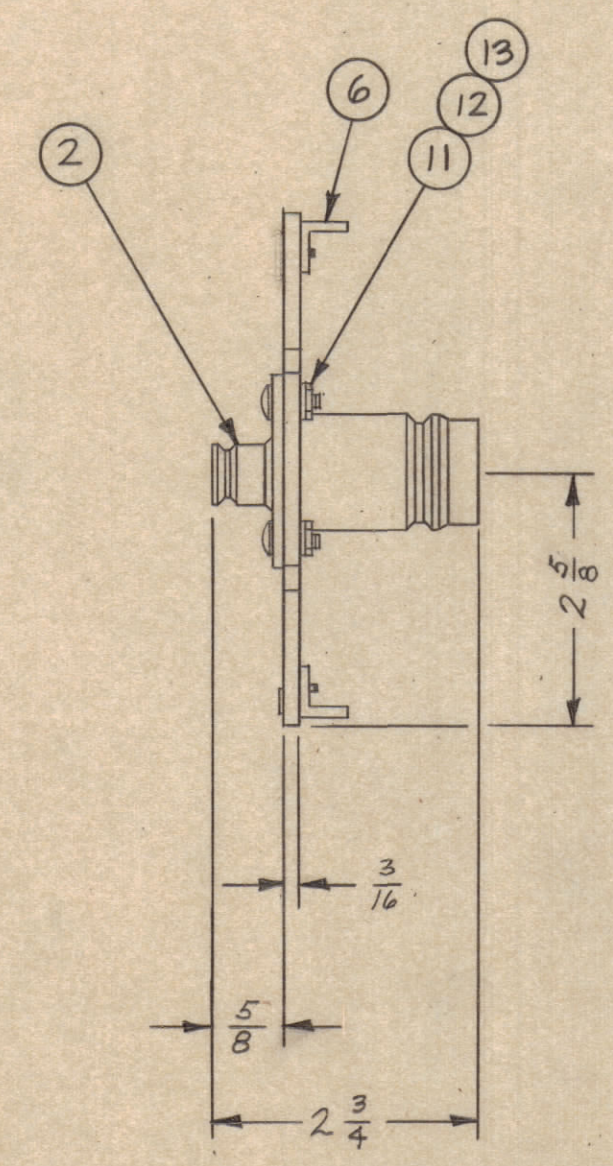
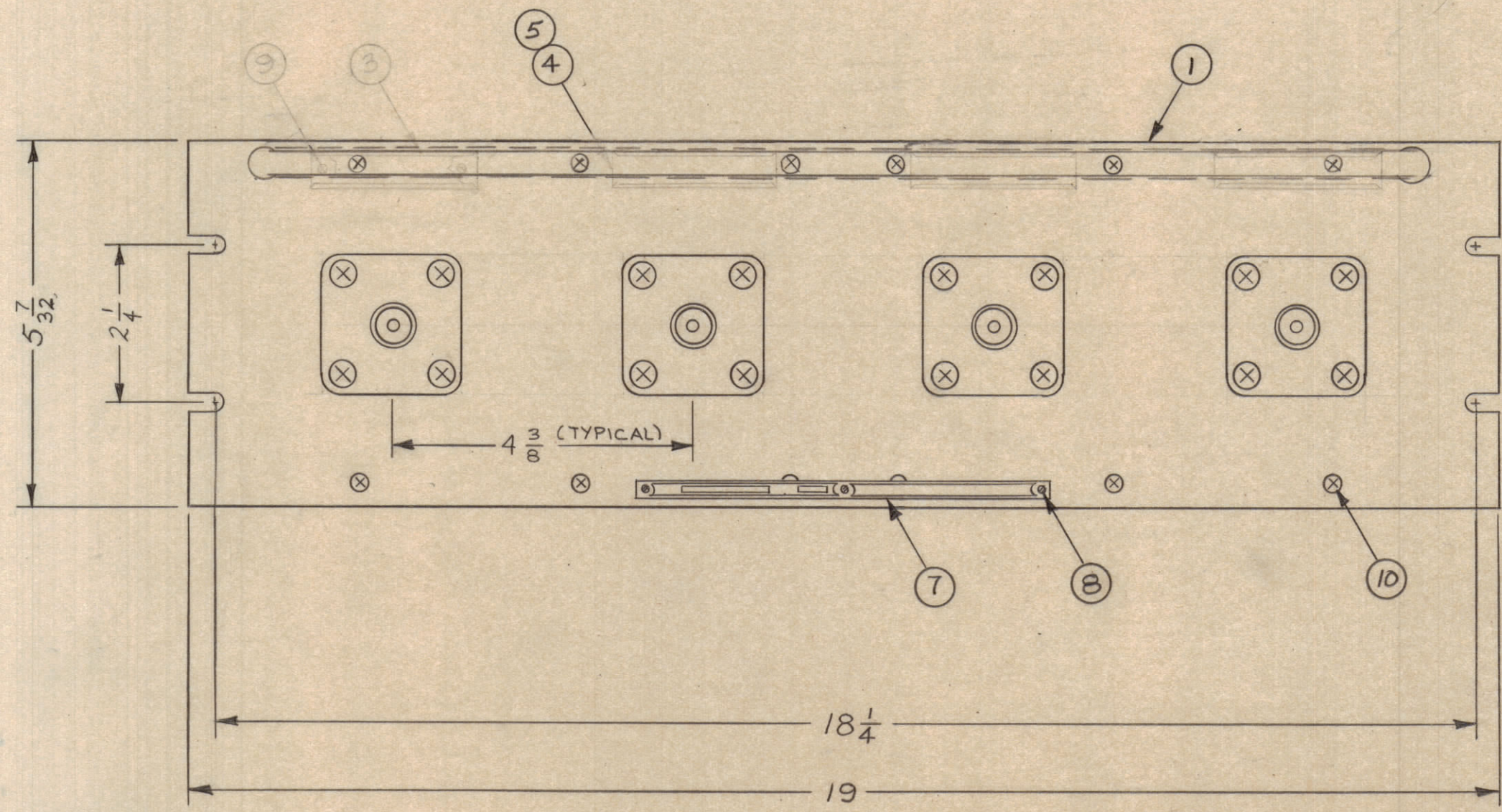

REQ'D.	ITEM	PART NUMBER	DESCRIPTION	SYMBOL
X	14	S-721	TEST PROCEDURE	
16	13	NTH 1032 BN 12	NUT, HEXAGON	
16	12	LWE 10 MRN	WASHER, LOCK, EXTERNAL	
16	11	SCBPI032BN9	SCREW, MACHINE	
12	10	SCFPO632BN5	SCREW, MACHINE	
8	9	SCFPO34BN4	SCREW, MACHINE	
3	8	SFB0256SN3	SCREW, THREAD CUTTING	
1	7	NP-250	NAMEPLATE, IDENTIFICATION	
2	6	PM-490	BRACE, PANEL	
4	5	PX-396-1	GUARD, TAB	
4	4	PR-106-17	TAB, PAPER	
4	3	MS-576	HOLDER, CARD	
4	2	JJ-139	ADAPTER, CONNECTOR	
1	1	MS-1078-2	MACHINING, FRONT PANEL	

MATERIAL		LIST OF MATERIAL	
ALUMINUM		THE TECHNICAL MATERIEL CORP. MAMARONECK, NEW YORK	
FINISH TMC SMOOTH GRAY SEMI-GLOSS ENAMEL		TITLE PATCH PANEL, QUICK DISCONNECT QDL TO QDS	
UNLESS OTHERWISE SPECIFIED DIMENSIONS ARE IN INCHES AND INCLUDE CHEMICALLY APPLIED OR PLATED FINISHES		DRAWN M. TANTILLO	DATE 11-1-62
DECIMALS .X ± .05 .XX ± .01 .XXX ± .005		CHECKED JHO	DATE 11-23-62
FRACTIONS ± 1/64 ANGLES ± 0° 30'		ELECT. DES.	DATE
TOLERANCES		MECH. DES.	DATE
		DATE 12/3/62	

QTY./UNIT	MODEL USED ON	ASSY. NO.
1	QDP-2C1X4	
SCALE	CODE	

NOTES

THE CONTENTS OF THIS DRAWING ARE THE EXCLUSIVE PROPERTY OF THE TECHNICAL MATERIEL CORP. ITS UNAUTHORIZED USE OR REPRODUCTION IN WHOLE OR IN PART IS STRICTLY FORBIDDEN.

QDP-2C1X4
A