

REVISIONS						
ZONE	SYM.	DESCRIPTION	DATE	E.M.N. NO.	DRAFT	CHKD
B7, B1, B3	A	NOTES, CHART, ITEM (1) ADDED; ITEM (2) QTY WAS 16, DIMS CLARIFIED	3-21-63	8501	RC	JW
C2, A7		ITEM (8) WAS "SEE NAMEPLATE NOTE", NAMEPLATE NOTE DELETED				

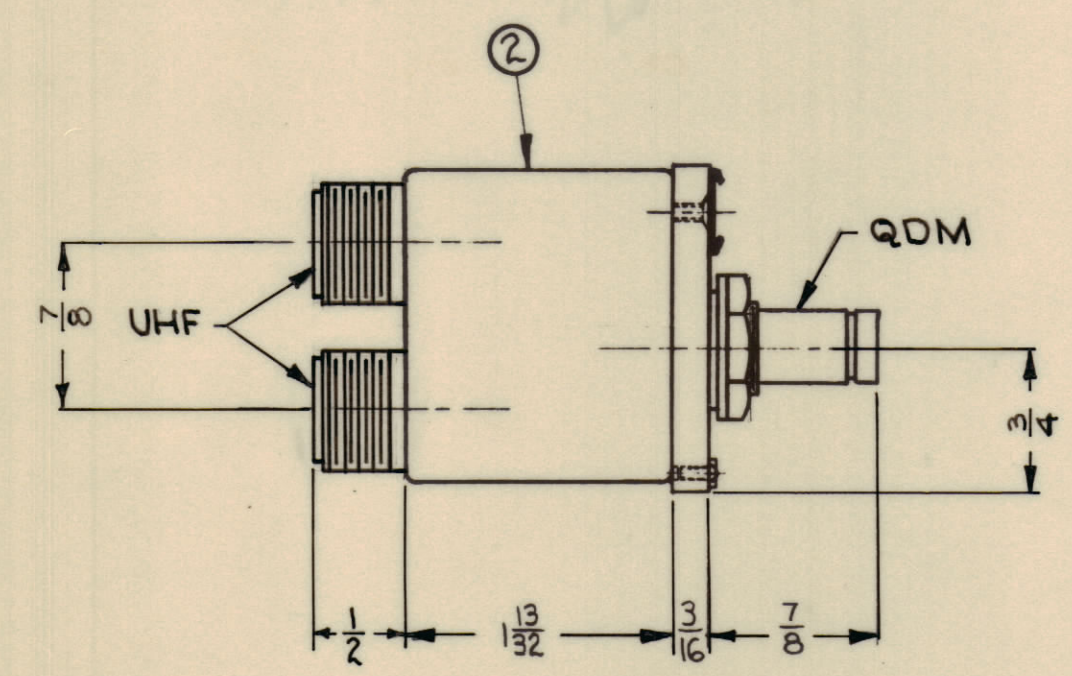
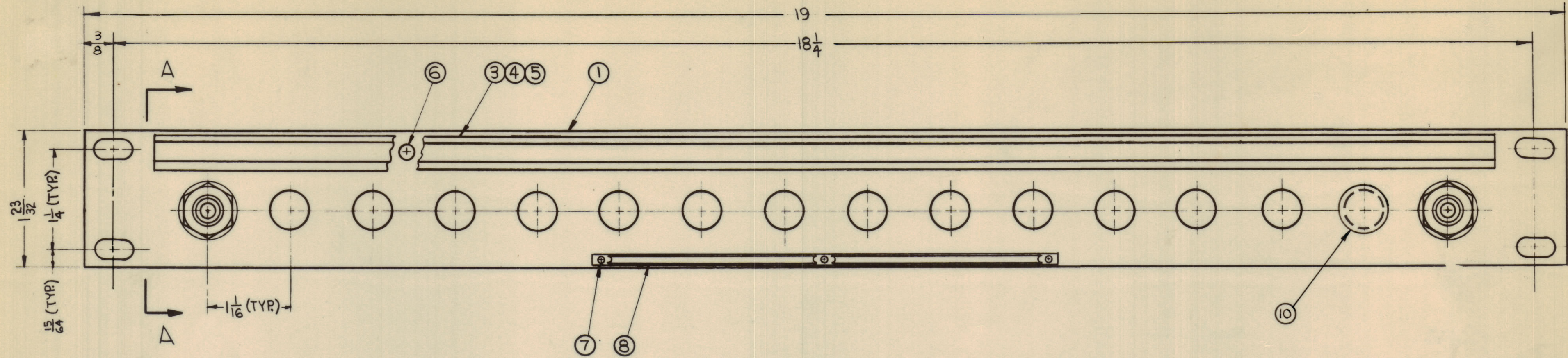

SIDE VIEW A-A

- NOTES:
1. SWITCHES (ITEM 2) ARE MOUNTED FROM LEFT TO RIGHT.
 2. WHEN SWITCH MOUNTING HOLES ARE NOT UTILIZED, PLUG BUTTONS (ITEM 10) ARE MOUNTED ON FACE OF PANEL.
 3. REFER TO CHART FOR APPLICATION OF PLUG BUTTONS (ITEM 10) WHEN REQUIRED.

SPP-30716	16	0
SPP-30715	15	1
SPP-30714	14	2
SPP-30713	13	3
SPP-30712	12	4
SPP-30711	11	5
SPP-30710	10	6
SPP-3079	9	7
SPP-3078	8	8
SPP-3077	7	9
SPP-3076	6	10
SPP-3075	5	11
SPP-3074	4	12
SPP-3073	3	13
SPP-3072	2	14
SPP-3071	1	15
MODEL	QUANTITY ITEM 2	QUANTITY ITEM 10

SEE CHART	ITEM	PART NUMBER	DESCRIPTION	SYMBOL
	10	HB-101-11-G	PLUG, BUTTON	
X	9	S-692	TEST PROCEDURE	
	8	NP-251	NAMEPLATE IDENTIFICATION	
	7	SFBP0256SN3	SCREW, THREAD CUTTING	
	6	SCFP0348BN3	SCREW, MACHINE	
	5	PX-396-17	GUARD, TAB	
	4	PR-101-17	TAP, PAPER	
	3	MS-1184	HOLDER, CARD	
SEE CHART	2	SW-308	SWITCH, JACK ASSEMBLY	
	1	MS-2973	MACHINING, FRONT PANEL	

LIST OF MATERIAL			
MATERIAL	ALUMINUM 19x3 13/32 x 3/16	THE TECHNICAL MATERIEL CORP. MAMARONECK, NEW YORK	
FINISH	SI15 TMC SMOOTH GREY ENAMEL	TITLE	PANEL, PATCH R.F. SWITCHING
UNLESS OTHERWISE SPECIFIED DIMENSIONS ARE IN INCHES AND INCLUDE CHEMICALLY APPLIED OR PLATED FINISHES		DRAWN	R. Lurich
DECIMALS .X ± .05 .XX ± .01 .XXX ± .005	FRACTIONS ± 1/64 ANGLES ± 0° 30'	CHECKED	DATE 6-5-62
TOLERANCES		ELECT. DES.	DATE 6-26-62
		MECH. DES.	DATE 6/27/62
		FINAL APPROVAL	
		SPP-30716	
		SHEET	
		REV. LTR.	

SEE CHART		
Q'TY./UNIT	MODEL USED ON	ASS'Y. NO.
SCALE	CODE	
DO NOT SCALE		
THE CONTENTS OF THIS DRAWING ARE THE EXCLUSIVE PROPERTY OF THE TECHNICAL MATERIEL CORP. ITS UNAUTHORIZED USE OR REPRODUCTION IN WHOLE OR IN PART IS STRICTLY FORBIDDEN.		

NOTES

SPP-30716 A