

OAK MANUFACTURING CO. 1260 CLYBORN AVE., CHICAGO 10, ILL. 47569-FX3
 CUSTOMER Technical Materiel Co
 CUSTOMER'S PART NO. SW-110

OAK TYPE F SWITCH

XFK
 SW-110
 4-40 THREAD

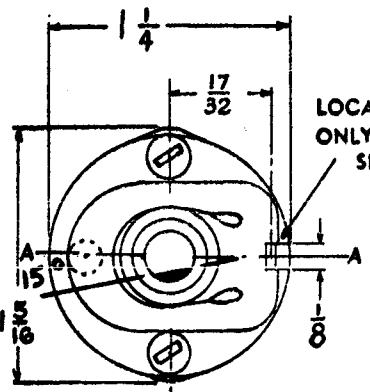

LOCATING KEY ONLY AT POINT SHOWN

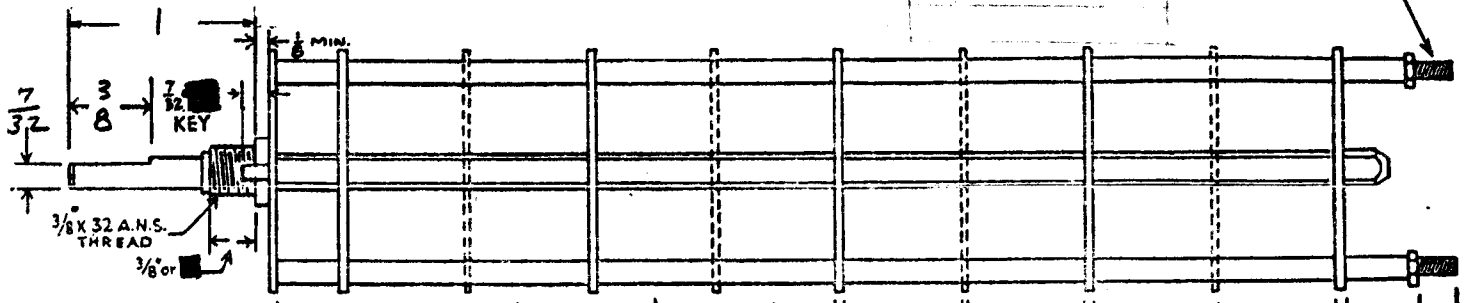

SHOW CUT AWAY PORTION OF FLAT IN BLACK AND GIVE ANGLE TO LINE A-A. $\pm 3^\circ$ STANDARD RMA KNURLED AND SLOTTED SHAFT ALSO AVAILABLE

FRONT AND REAR OF SECTIONS VIEWED FROM FRONT OR KNOB END OF SWITCH IN EXTREME COUNTER-CLOCKWISE POSITION

NUMBER OF SECTIONS $\frac{3}{2}$
 NUMBER OF POSITIONS $\frac{3}{2}$
 ANGLE OF THROW 30° (30° OR 60°)

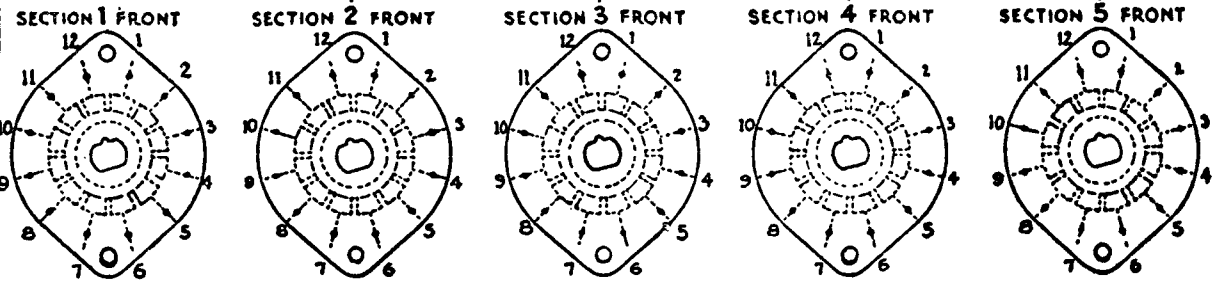

SYMBOLS USED IN MARKING PRINT

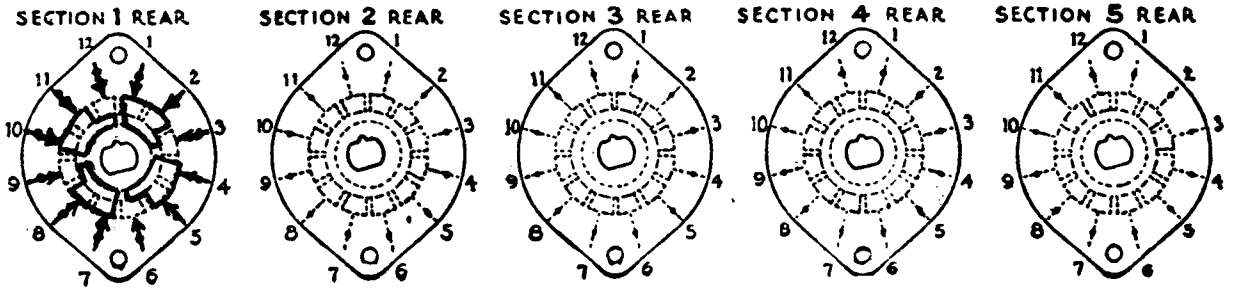
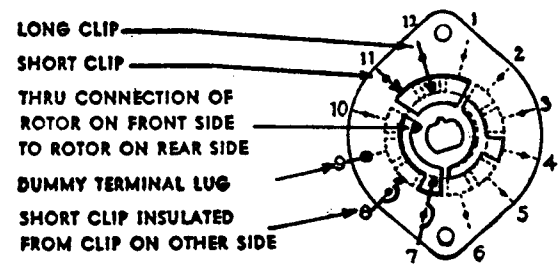

OUTLINE ROTOR BLADES AS SHOWN ABOVE WITH SWITCH IN EXTREME COUNTER-CLOCKWISE POSITION

USED ON
 Model XFK
 A-682

CUSTOMER NOTES

① sections 2 & 3 identical to section 1

SPECIFICATIONS

SHORTING TYPE CONTACTS NON-SHORTING IF NOT SPECIFIED SHORTING TYPE WILL BE SUPPLIED.
 INSULATION: $\frac{1}{16}$ " BAKELITE ; $\frac{1}{8}$ " MYCALEX SPECIFY IMPREGNATION IF REQUIRED.
 FINISH REQUIREMENTS: COMMERCIAL ; ARMY ; NAVY ; SALT TEST (IF ANY GIVE DETAILS) 200 Hour
 CONTACTS AND ROTORS: SILVER PLATED BRASS ; SOLID SILVER ALLOY ; IF NOT SPECIFIED SILVER PLATED BRASS WILL BE SUPPLIED.
 MOUNTING HARDWARE: SUPPLY $\frac{1}{2}$ " 32 NUTS $\frac{1}{2}$ " ACROSS FLATS; MATERIAL _____ PLATING _____
 $\frac{1}{2}$ " INTERNAL TOOTH LOCKWASHER; MATERIAL _____ PLATING _____
 STAMP PART NUMBER SW-110 ON FRONT PLATE, YES NO (NUMBER)

SW-110

XFK S2

SUPERCEDES₂ DATE 3/5/57
 AES006