

REQ. PER UNIT	USED ON			SW-196 G
	MODEL	ASS'Y. NO.	DATE	
1	SW-196		1/24/58	

NOTES

1. CASE: MATERIAL - BRASS
FINISH - S-522 TMC SMOOTH GRAY VINYL ENAMEL
2. CONNECTORS FINISH:
BODIES - RHODIUM FLASH
CONTACTS - GOLD FLASH
3. FOR MOUNTING - 13/16 DIAMETER HOLE, 1 REQUIRED
4. MAXIMUM PANEL THICKNESS - 3/16

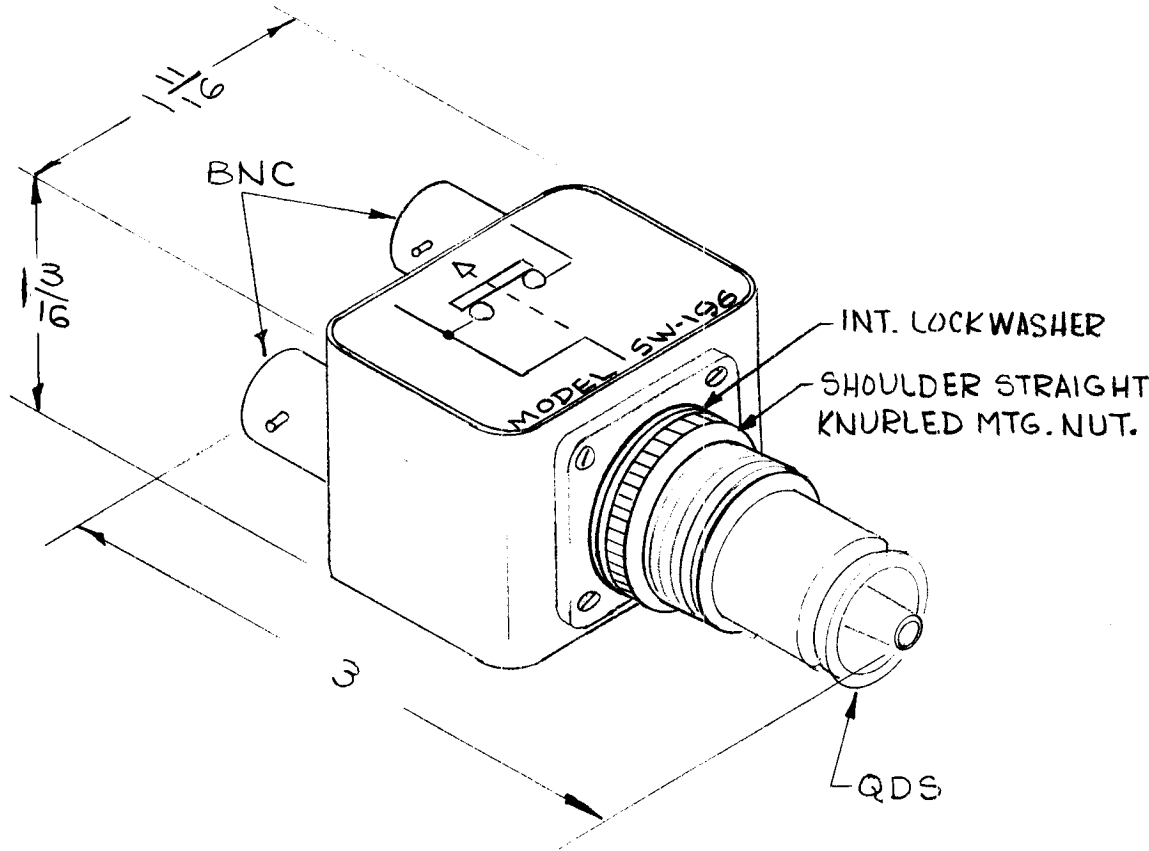

NOTE: ASSIGNED PATENT NO. 2,767,267

REQ.	ITEM	PART NO.	DESCRIPTION			SYMBOL
		#	THE TECHNICAL MATERIEL CORP. MAMARONECK, NEW YORK			
		STOCK SIZE	SWITCH, RF,			
		SEE NOTES	DUAL BNC to SINGLE QDS			
		MATERIAL				
		#				
		#				
			TYPE & TEMPER	HEAT TREAT. SPEC.	DRAWN	CHECKED
			SEE NOTES			
			FINISH & SPEC. NO.	ELEC. DES. APP.	MECH. DES. APP.	
						SW-196 G

ISSUE	ITEM	CHANGED FROM	DATE	CH. NO.	DRAFTS	CHECKER	ENG. APP.
G	-	PATENT NOTE ADDED	9/3/68	14846	P.V.	QCB	M.H.
F	2	PICTORIAL CLARIFIED					
F	1	NOTES ADDED	3-20-63	8507			

TOLERANCES: SCALE: 2A-1498

DEC. DIM. ±
FRAC. DIM. ±
ANGULAR DIM. ±

MAXIMUM ALLOWABLE TOLERANCES HAVE BEEN DETERMINED AND ANY DEVIATIONS WILL BE CAUSE FOR REJECTION.
REMOVE ALL BURRS AND SHARP EDGES