

SW-237

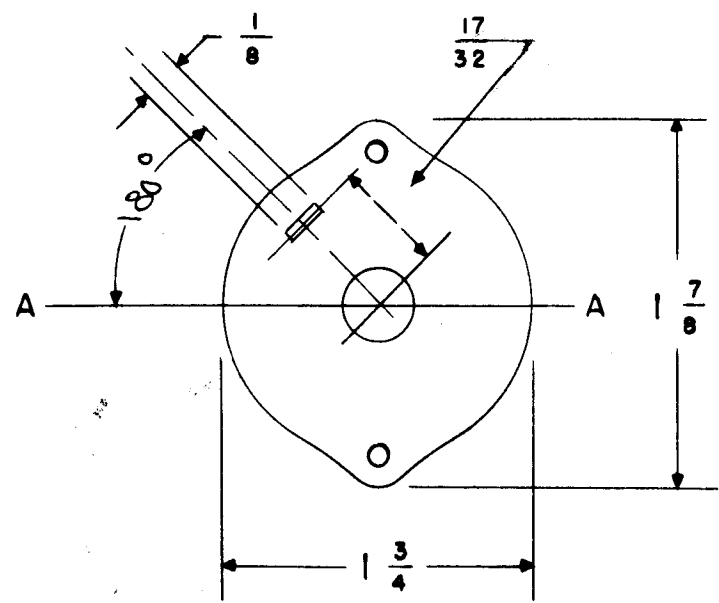

FRONT & REAR SECTIONS VIEWED FROM FRONT OR KNOB END OF SWITCH IN EXTREME COUNTER CLOCKWISE POSITION

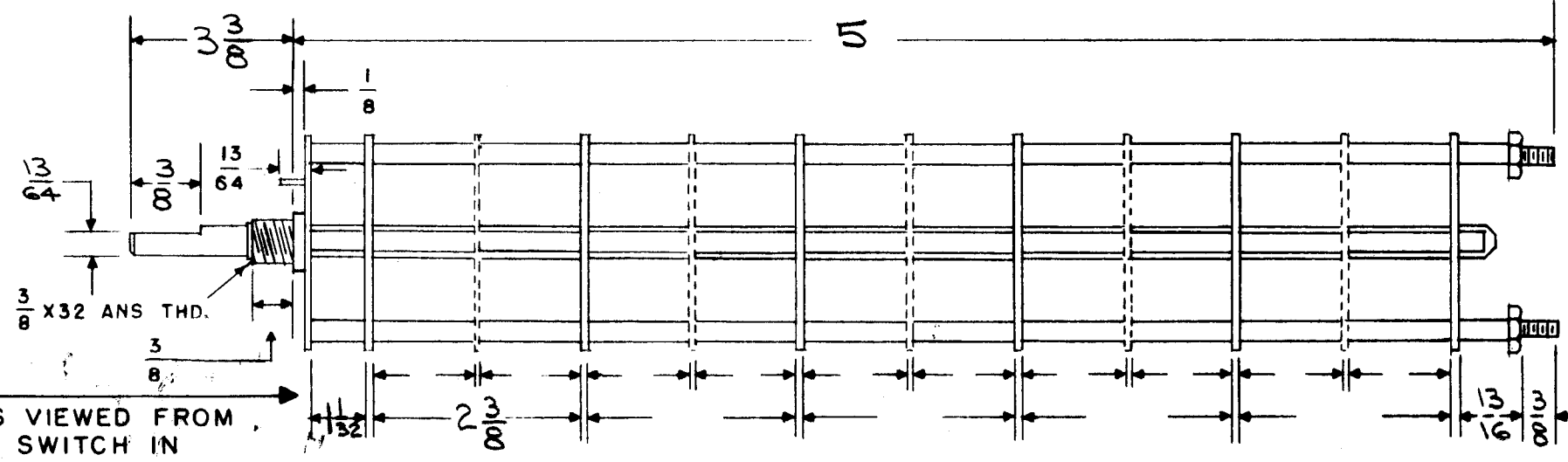

DRAW IN FLAT ON ABOVE SHAFT IN EXTREME COUNTER CLOCKWISE POSITION AND SHOW ANGLE IN REFERENCE TO LINE A-A

NUMBER OF SECTIONS 2
 NUMBER OF POSITIONS NO DETENT
 ANGLE OF THROW _____ (30° OR 60°)

PART NUMBER SW-237
 STAMP ON FRONT PLATE YES NO _____

CONTACTS & ROTORS: (IF NOT SPECIFIED, SHORTING TYPE WILL BE SUPPLIED)
 SHORTING _____ NON SHORTING

MATERIAL: (IF NOT SPECIFIED, SILVER PLATED BRASS WILL BE SUPPLIED)
 SILVER PLATED BRASS SILVER ALLOY _____

INSULATION: BAKELITE CERAMIC _____
 SPECIFY IMPREGNATION IF REQUIRED _____

FINISH REQUIREMENTS: COMMERCIAL ARMY _____ NAVY _____
 SALT TEST (IF ANY GIVE DETAILS) _____

HARDWARE: SUPPLY
 _____ 3/8-32 NUTS _____ ACROS FLATS MAT. _____ PLATING _____
 _____ 3/8 INT TOOTH LOCKWASHERS MAT. _____ PLATING _____

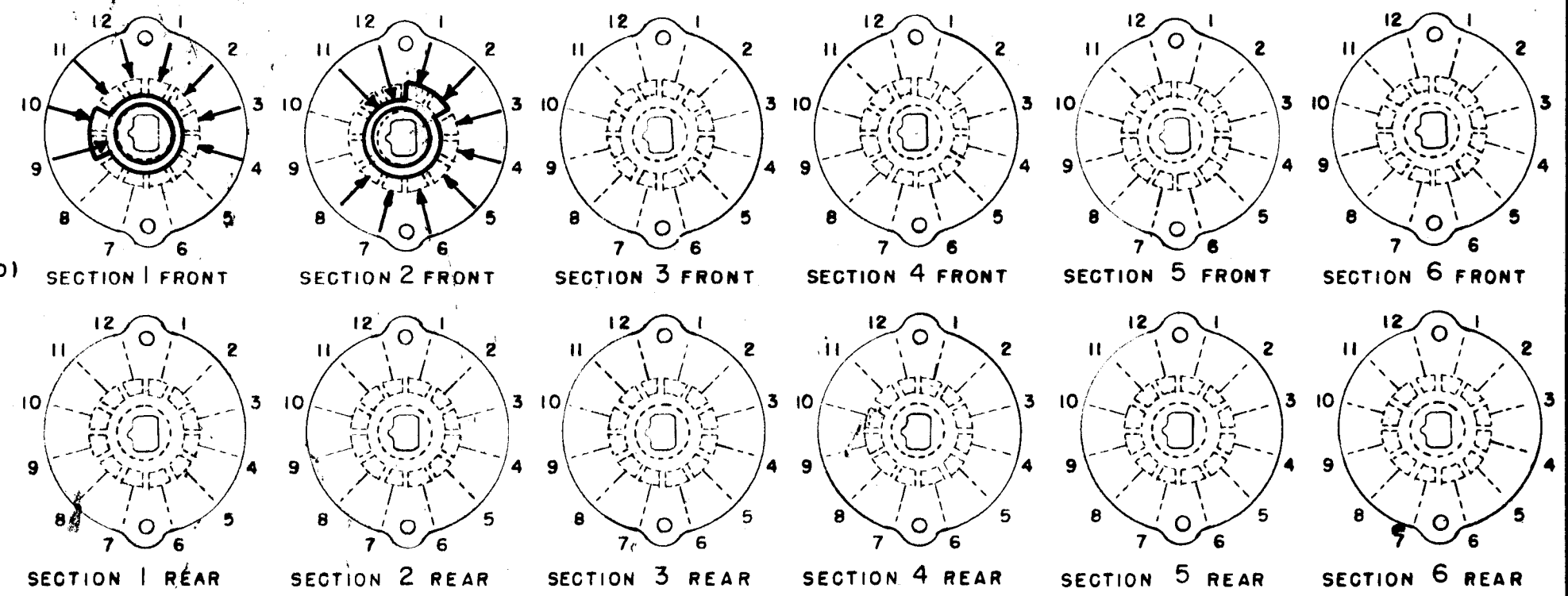

SYMBOLS USED IN MARKING PRINT →

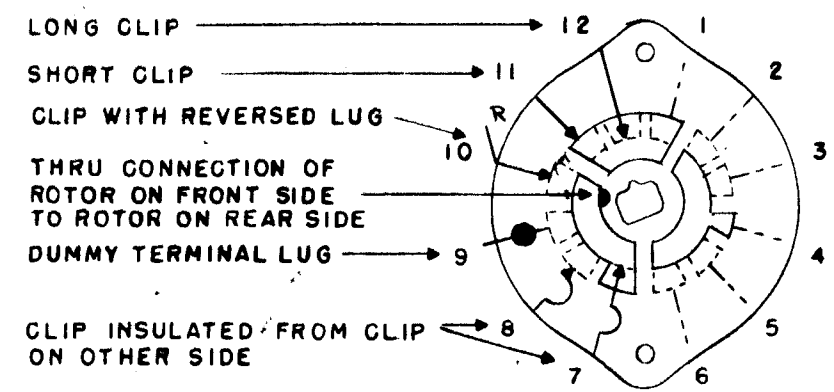

OUTLINE ROTOR BLADES AS SHOWN ABOVE WITH SWITCH IN EXTREME COUNTER-CLOCKWISE POSITION

OAK SWITCH; TYPE AC
 SECTION 1+2 CERAMIC AC TYPE WAFER
 NO DETENT
 SHAFT NOT REMOVABLE

ISSUE	ITEM	CHANGED FROM	DATE	CH. NO.	DRAFTS	CHECKER	ENG. APP.
TOLERANCES			SCALE:				
DEC. DIM. ±			MAXIMUM ALLOWABLE TOLERANCES HAVE BEEN DETERMINED AND ANY DEVIATIONS WILL BE CAUSE FOR REJECTION.				
FRAC. DIM. ±			REMOVE ALL BURRS AND SHARP EDGES				
ANGULAR DIM. ±							

REQ. PER UNIT	MODEL	PROJECT NO.	ASSY. NO.	DATE

REQ. ITEM	PART NO.	DESCRIPTION	SYMBOL
THE TECHNICAL MATERIEL CORP. MAMARONECK, NEW YORK			
MULTIPLIER BANDSWITCH			
MATERIAL			
TYPE & TEMPER			
HEAT TREAT. SPEC.			
DRAWN		CHECKED	
FINAL APPROVAL			
FINISH & SPEC. NO.		ELEC. DES. APP. MECH. DES. APP.	
SW-237			