

SW-277

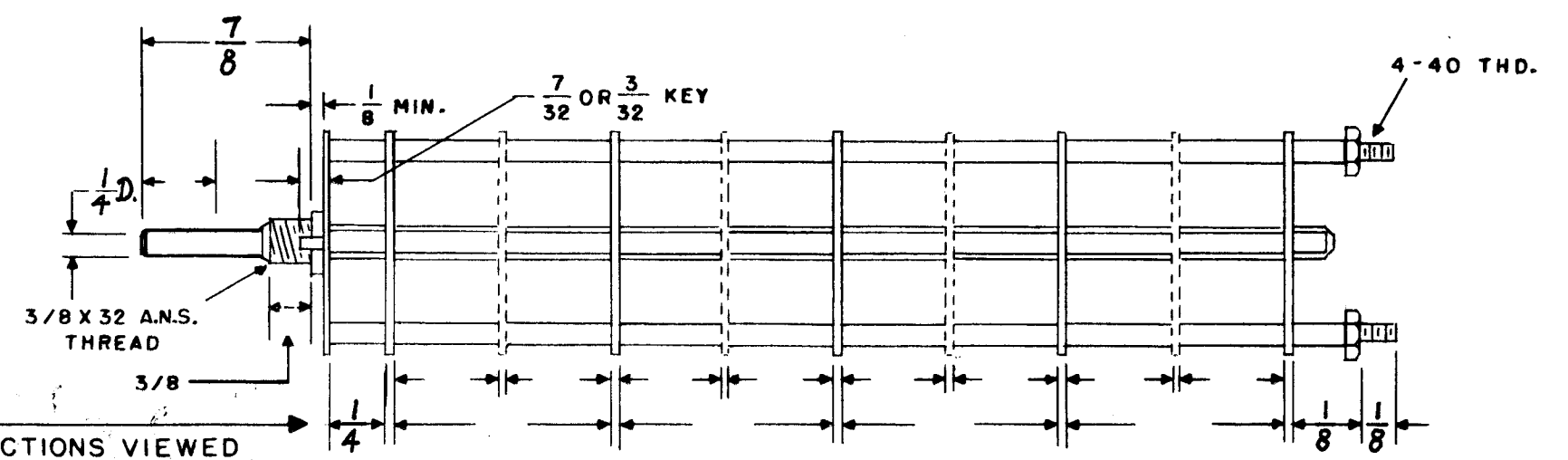
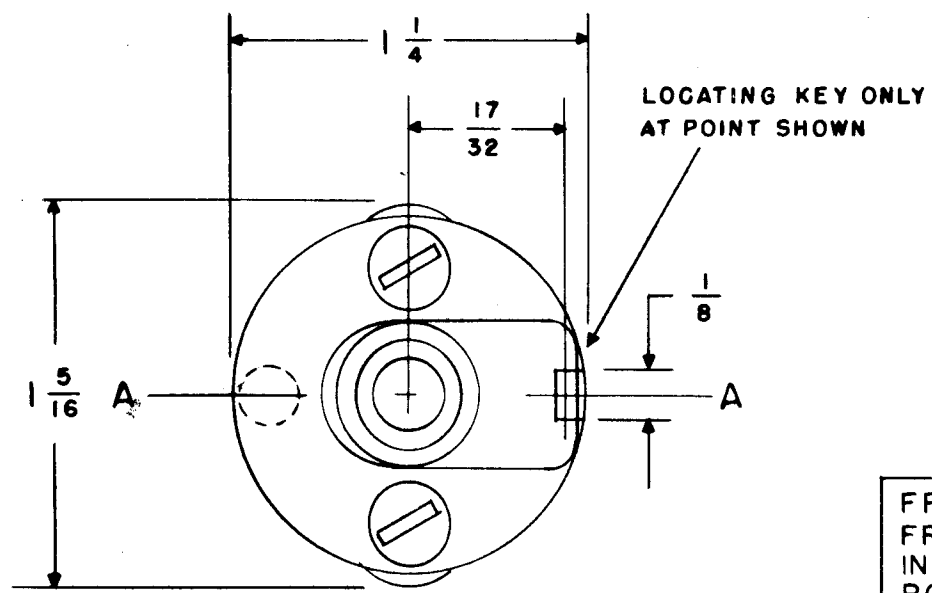

FRONT & REAR OF SECTIONS VIEWED FROM FRONT OR KNOB END OF SWITCH IN EXTREME COUNTER-CLOCKWISE POSITION

SHOW CUT AWAY PORTION OF FLAT IN BLACK AND GIVE ANGLE TO LINE A-A $\pm 3^\circ$. (STANDARD RMA KNURLED AND SLOTTED SHAFT ALSO AVAILABLE)

NUMBER OF SECTIONS 1
 NUMBER OF POSITIONS 4
 ANGLE OF THROW 30° (30° OR 60°)

PART NUMBER SW-277
 STAMP ON FRONT PLATE YES NO

CONTACTS & ROTORS: (IF NOT SPECIFIED, SHORTING TYPE WILL BE SUPPLIED)
 SHORTING NON SHORTING

MATERIAL: (IF NOT SPECIFIED, SILVER PLATED BRASS WILL BE SUPPLIED)
 SILVER PLATED BRASS SILVER ALLOY

INSULATION: 1/16 BAKELITE 1/8 MYCALEX
 SPECIFY IMPREGNATION IF REQUIRED _____

FINISH REQUIREMENTS: COMMERCIAL _____ ARMY _____ NAVY _____
 SALT TEST (IF ANY GIVE DETAILS) _____

HARDWARE: SUPPLY
 _____ 3/8-32 NUTS _____ ACROSS FLATS
 _____ 3/8 INTERNAL TOOTH LOCKWASHERS

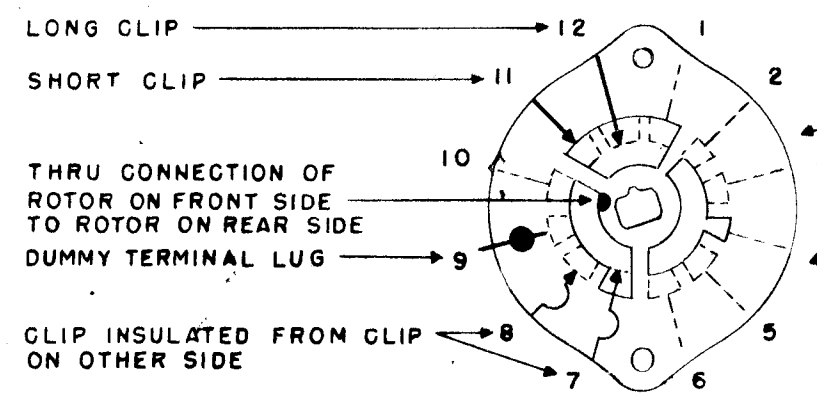
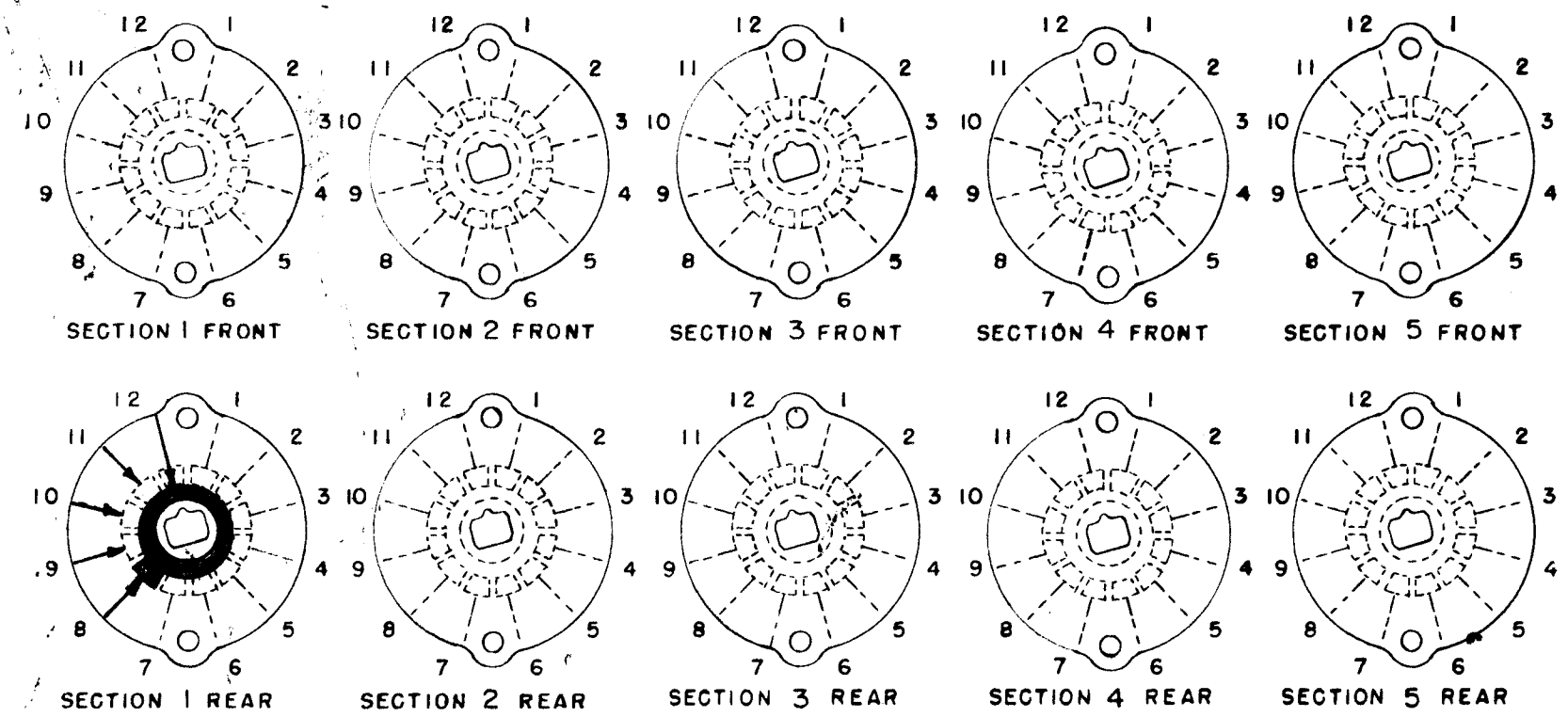

SYMBOLS USED IN MARKING PRINT

OAK TYPE F SWITCH

ISSUE	ITEM	CHANGED FROM	DATE	CH. NO.	DRAFTS	CHECKER	ENG. APP.
TOLERANCES			SCALE:				
DEC. DIM. \pm			MAXIMUM ALLOWABLE TOLERANCES HAVE BEEN DETERMINED AND ANY DEVIATIONS WILL BE CAUSE FOR REJECTION.				
FRAC. DIM. \pm			REMOVE ALL BURRS AND SHARP EDGES				
ANGULAR DIM. \pm							

REQ. PER UNIT	MODEL	PROJECT NO.	ASS'Y. NO.	DATE
	AFC-1			7-29-60
USED ON				

REQ. ITEM	PART NO.	DESCRIPTION	SYMBOL
STOCK SIZE		THE TECHNICAL MATERIEL CORP. MAMARONECK, NEW YORK	
MATERIAL		SWITCH, ROTARY	
TYPE & TEMPER	HEAT TREAT. SPEC.	DRAWN	CHECKED
		<i>EFM</i>	<i>JDe</i>
FINISH & SPEC. NO.		FINAL APPROVAL	
		<i>EFM</i>	
		SW-277	
		ELEC. DES. APP.	MECH. DES. APP.