

TMC PART NO.	CONTACT ARRANGEMENT	BUTTON SIZE	LAMP	MFG P/N	SWITCH ACTION STYLE
SW394-1	1	B	A	1018	MOMENTARY
SW394-2	2	B	A	1182	MAINTAINED
SW394-3	1	C	A	1118	MAINTAINED
SW394-4	1	D	A	1018	MOMENTARY
SW394-5	1	B	A	1118	MAINTAINED
SW394-6	2	B	A	1082	MOMENTARY

E		REVISIONS						
		SYM	DESCRIPTION	DATE	E.M.N. NO.	DRAFT	CHKD	APPD
SW 394		Ø	ORIGINAL RELEASE FOR PRODUCTION	5-14-65	X	CJL		
		A	CHART 3 CODE B STYLE WAS 2	5-20-65	14107	CJL		
		B	ENGRAVING COLOR & MFG CODE COLMS ADDED ON CHART 3 SIZE WAS TYPE	9/20/65	14852	H.V.V.		
		C	CHT 1 SIZE COL. CHT 2 MATL COL ADDED	12/2/65	15277	H.V.V.		
		D	CHART 1, 3, 4, 5 UPDATED. "P" ADDED TO NOMANCLATURE PANEL ADAPTER ADDED	12/2/65	15444	H.V.V.		
		E	ON P/NO CART SW 394-5 & SW 394-6 ADDED ON CHART 1 CODE 10 & 11 ADDED - DIMS: .375, .52, .035 & 13/32 ADDED	1-21-65	15610	G.D.L.		

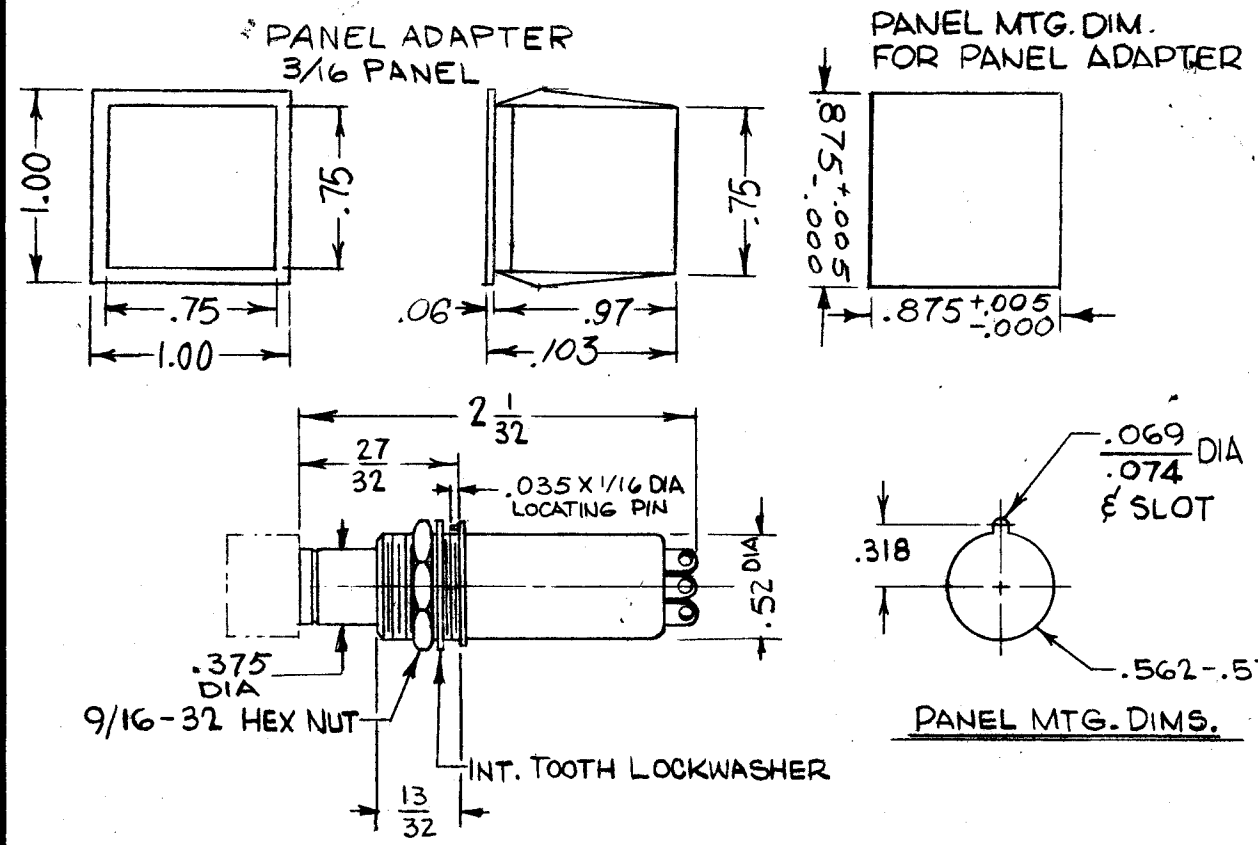

CHART 2
LENS COLOR

ENGRAVING FIELD	COLOR	TMC CODE	MFG CODE	MATERIAL
WHITE	RED	R	R1-L	HIGH TEMP POLYCARBONATE
WHITE	BLUE	B	B2-L	"
WHITE	GREEN	G	G1-L	"
BLACK	YELLOW	Y	Y1-L	"
WHITE	AMBER	A	A1-L	"
BLACK	WHITE	W	W1-L	"

CHART 1
ENGRAVING

CODE	INFORMATION	SIZE
1	FAULT RESET	.130
2	TUNE SYNC.	.130
3	A1	.160
4	A2	.160
5	B1	.160
6	B2	.160
7	B+	.160
8	OVL D RESET	.130
9	TAPE READ	.130
10	HV	.160
11	TUNE	.160

CHART 3
BUTTON SIZE

CODE	A	B	MFG STYLE NO	C	STYLE
A	1/2	7/16	L56	1/2	1
B	5/8	7/16	L48	5/8	1
C	1/2	3/8	L30	—	2
D	3/4	7/16	L41	3/4	1

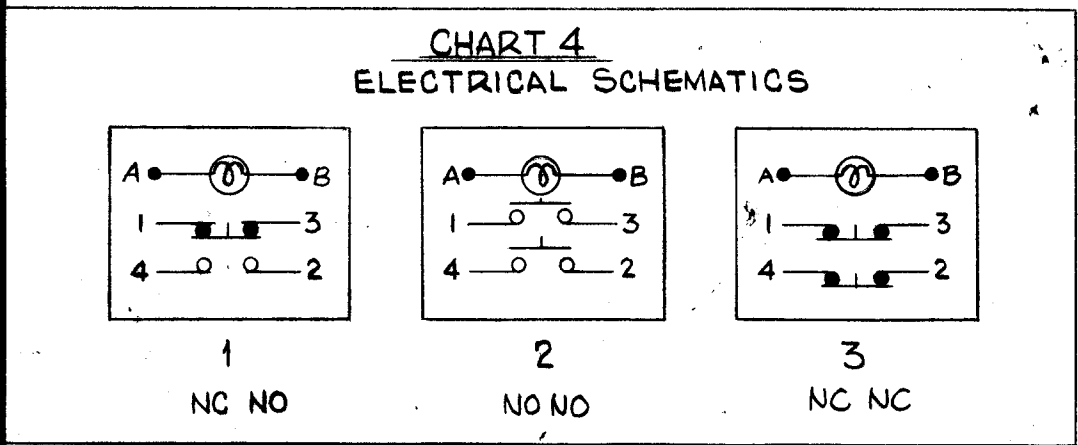
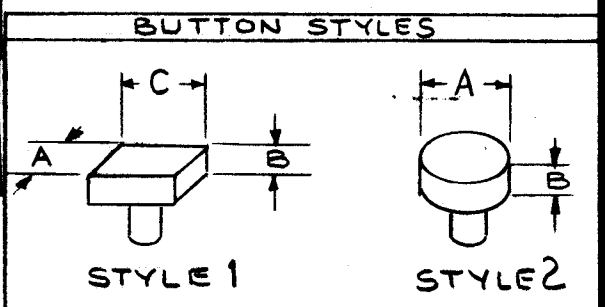

CHART 5
LAMP

CODE	TYPE	VOLTAGE	AMPS
A	No. 327	28	.04
B	No. 328	6	.2
C	No. 330	14	.08
D	No. NE2J	110-125	

SW 394 - 1 A
BASIC TMC NO. LENS COLOR - ENGRAVE
TMC PART NO. TO BE IN ABOVE FORM

ADD "P" WHEN PANEL ADAPTER IS REQUIRED
NOTE: OMIT THIS DIGIT WHEN NO ENGRAVING IS REQUIRED

REQ'D.	ITEM	PART NUMBER	DESCRIPTION	SYMBOL
EATON, F. LIST OF MATERIAL				
MATERIAL			THE TECHNICAL MATERIEL CORP.	
FINISH			MAMARONECK, NEW YORK	
TITLE			SWITCH, PUSHBUTTON	
UNLESS OTHERWISE SPECIFIED DIMENSIONS ARE IN INCHES AND INCLUDE CHEMICALLY APPLIED OR PLATED FINISHES		DRAWN H. AUSTIN	DATE 4-13-65	FINAL APPROVAL
DECIMALS .X ± .05 .XX ± .01 .XXX ± .005		CHECKED J.M. JOE	DATE 5-13-65	DATE 5/14/65
FRACTIONS ± 1/64 ± 0° 30'		ELECT. DES.	DATE	DATE
TOLERANCES		MECH. DES.	DATE	DATE
SHEET			SW394 E	
REV. LTR.				

STANDARD DRAWING

Q'TY./UNIT	MODEL USED ON	ASS'Y. NO.
SCALE #	CODE C	S401-393
THE CONTENTS OF THIS DRAWING ARE THE EXCLUSIVE PROPERTY OF THE TECHNICAL MATERIEL CORP. ITS UNAUTHORIZED USE OR REPRODUCTION IN WHOLE OR IN PART IS STRICTLY FORBIDDEN.		

NOTES