

THE CONTENTS OF THIS DRAWING ARE THE EXCLUSIVE PROPERTY OF THE TECHNICAL MATERIEL CORP. ITS UNAUTHORIZED USE FOR REPRODUCTION IN WHOLE OR IN PART IS STRICTLY FORBIDDEN.

REQ. PER UNIT

USED ON

MODEL

ASS'Y. NO.

DATE

TCA-85/QDL

10-17-62

TCA-85/QDL

A

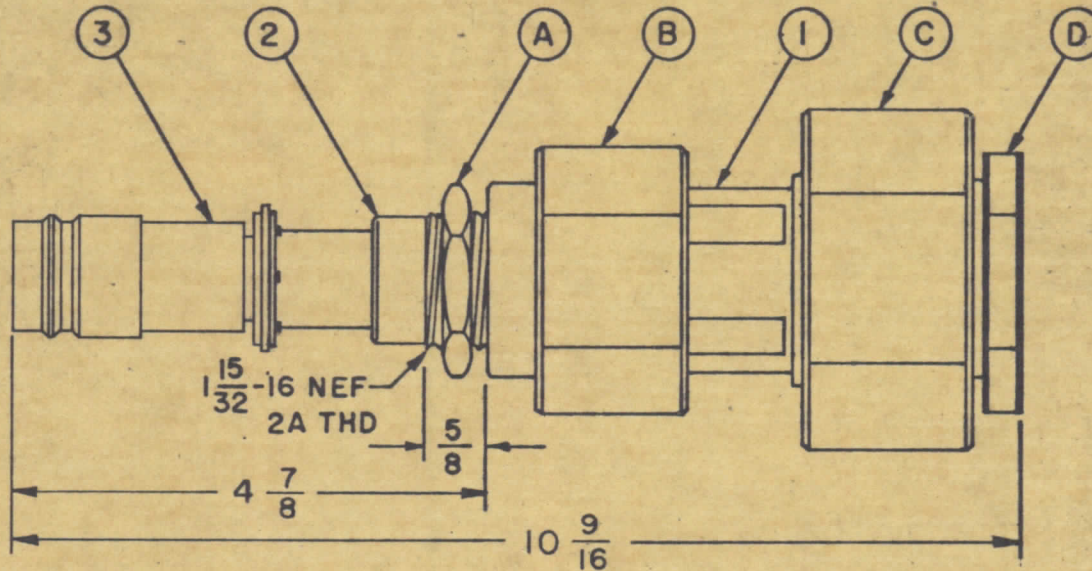

NOTE:

- | ITEM | ACROSS FLATS | ACROSS CORNERS |
|------|--------------|----------------|
| A | 2 | 2 5/16 |
| B | 2 3/8 | 2 3/4 |
| C | 3 | 3 7/16 |
| D | 2 | 2 5/8 |
- MOUNTING HOLE REQUIRED 1 1/2" DIA.
- MAXIMUM PANEL THICKNESS 3/8".
- ITEM 4, 5 & 6 SUPPLIED AS LOOSE ITEMS.

1	6	ID-273	INSTALLATION INSTRUCTION
1oz.	5	GL-118	SILICONE COMPOUND
1oz.	4	GL-117	ANTI-SEIZE COMPOUND
1	3	JJ-134	CONNECTOR RECEPTACLE
1	2	A-3086	CONNECTOR ADAPTER ASS'Y.
1	1	A-113	END SEAL ASSEMBLY

REQ. ITEM	PART NO.	DESCRIPTION	SYMBOL
THE TECHNICAL MATERIEL CORP. MAMARONECK, NEW YORK			
STOCK SIZE			
CONNECTOR ADAPTER ASSEMBLY			
MATERIAL			
UNLESS OTHERWISE SPECIFIED DIMENSIONS ARE IN INCHES AND INCLUDE CHEMICALLY APPLIED OR PLATED FINISHES		SCALE	
DECIMALS X ± .05 XX ± .01 XXX ± .005	TOLERANCES ± 1/64 ANGLES ± 0° 30'	CODE	
A REDRAWN & REVISED 11-2-62 7574 <i>gh</i> <i>Wde</i> <i>Wde</i>			
M.TANTILLO <i>Wde</i>		DRAWN <i>Wde</i> CHECKED <i>Wde</i> FINAL APPROVAL <i>Wde</i>	
TYPE & TEMPER HEAT TREAT. SPEC.		ELEC. DES. APP. MECH. DES. APP.	
FINISH & SPEC. NO.		TCA-85/QDL A	