

MASTER COPY
DO NOT DESTROY

MASTER COPY
DO NOT DESTROY

**TECHNICAL
MANUAL**

FOR

AX-789MFT

**PUBLICATION NUMBER
120-001**

ISSUE DATE

NOVEMBER 1978

MASTER COPY
DO NOT DESTROY

THE TECHNICAL MATERIEL CORPORATION

CABLE: TEPEI

700 FENIMORE ROAD, MAMARONECK, NY 10543 U.S.A.
TEL: 914-698-4800

TLX: 137-358

TWX: 710-566-1100

TMC (CANADA) LIMITED

TMC INTERNATIONAL

RR No. 5, Ottawa K1G 3N3 Ontario CANADA
TEL. 613-521-2050

TLX: 053-4146

NOTICE

THE CONTENTS AND INFORMATION CONTAINED IN THIS INSTRUCTION MANUAL IS PROPRIETARY TO THE TECHNICAL MATERIEL CORPORATION TO BE USED AS A GUIDE TO THE OPERATION AND MAINTENANCE OF THE EQUIPMENT FOR WHICH THE MANUAL IS ISSUED AND MAY NOT BE DUPLICATED EITHER IN WHOLE OR IN PART BY ANY MEANS WHATSOEVER WITHOUT THE WRITTEN CONSENT OF THE TECHNICAL MATERIEL CORPORATION.

RECORD OF REVISIONS

| NO. | ISSUED | DESCRIPTION | ENTERED | BY |
|-----|--------|--------------------|-----------|----|
| 001 | 7-7-82 | REVISED PG 2-3,2-4 | EMN 21972 | |
| 002 | | | | |
| 003 | | | | |
| 004 | | | | |
| 005 | | | | |
| 006 | | | | |
| 007 | | | | |
| 008 | | | | |
| 009 | | | | |
| 010 | | | | |

NOTE: Please file Technical Newsletters at back of manual for permanent record.

| Part Number | Description | Used On | Qty | Symbol Number |
|-------------|----------------|---------|-----|--------------------------------------|
| CC100-28 | CAP, FXD, CER | A5777 | 9 | C3, C4, C5, C6, C7, C8, C9, C10, C11 |
| RC07GF102J | RES, FXD | A5777 | 1 | R2 |
| RC07GF332J | RES, FXD | A5777 | 1 | R3 |
| RC32GF102J | RES, FXD | A5777 | 1 | R5 |
| RC07GF473J | RES, FXD | A5777 | 1 | R4 |
| RL156-10 | REL ARM | A5777 | 1 | K1 |
| RL156-19 | REL ARM | A5777 | 1 | K2 |
| SW559-N-1 | SW PB | A5777 | 2 | S3, S6 |
| SW559-P-1 | SW PB | A5777 | 2 | S1, S4 |
| TS171-4 | SKT, RELAY | A5777 | 1 | XK1 |
| TS171-5 | SKT, RELAY | A5777 | 1 | XK2 |
| 1N645 | DIODE | A5777 | 4 | CR1, CR3, CR4, CR5 |
| 2N1595 | TRANSISTOR | A5777 | 1 | Q1 |
| 2N1711 | TRANSISTOR | A5777 | 1 | Q2 |
| CE105-5-50 | CAP, FIX, ELEC | A5777 | 1 | C12 |

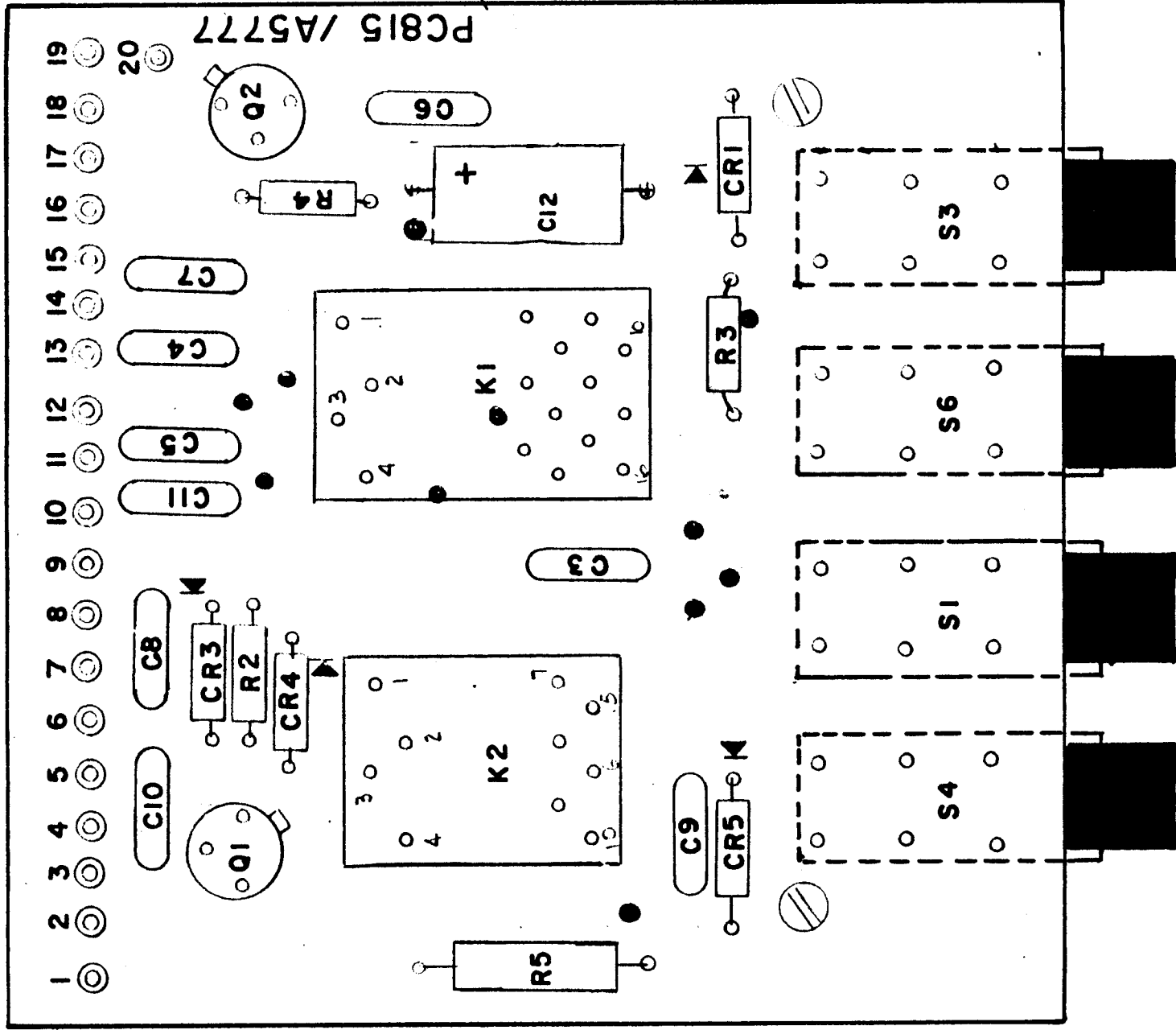

CONTROL ASSEMBLY
A5757(Z101)

| REVISIONS | | | | | | |
|-----------|-----|--|---------|----------|-------|-----------|
| ZONE | LTR | DESCRIPTION | DATE | E.M.N.NO | DRAFT | CHKD APPD |
| | | ORIGINAL RELEASE FOR PRODUCTION | 9-6-79 | 74 | MAC | |
| A | | changed PC802 to PC815 & A5757 to A5777 | 3-11-81 | 21871 | LAS | |
| B | | C12 Added, A5777 PIN 20 Revised, L-20 DS | 7-6-82 | 21971 | JD | |

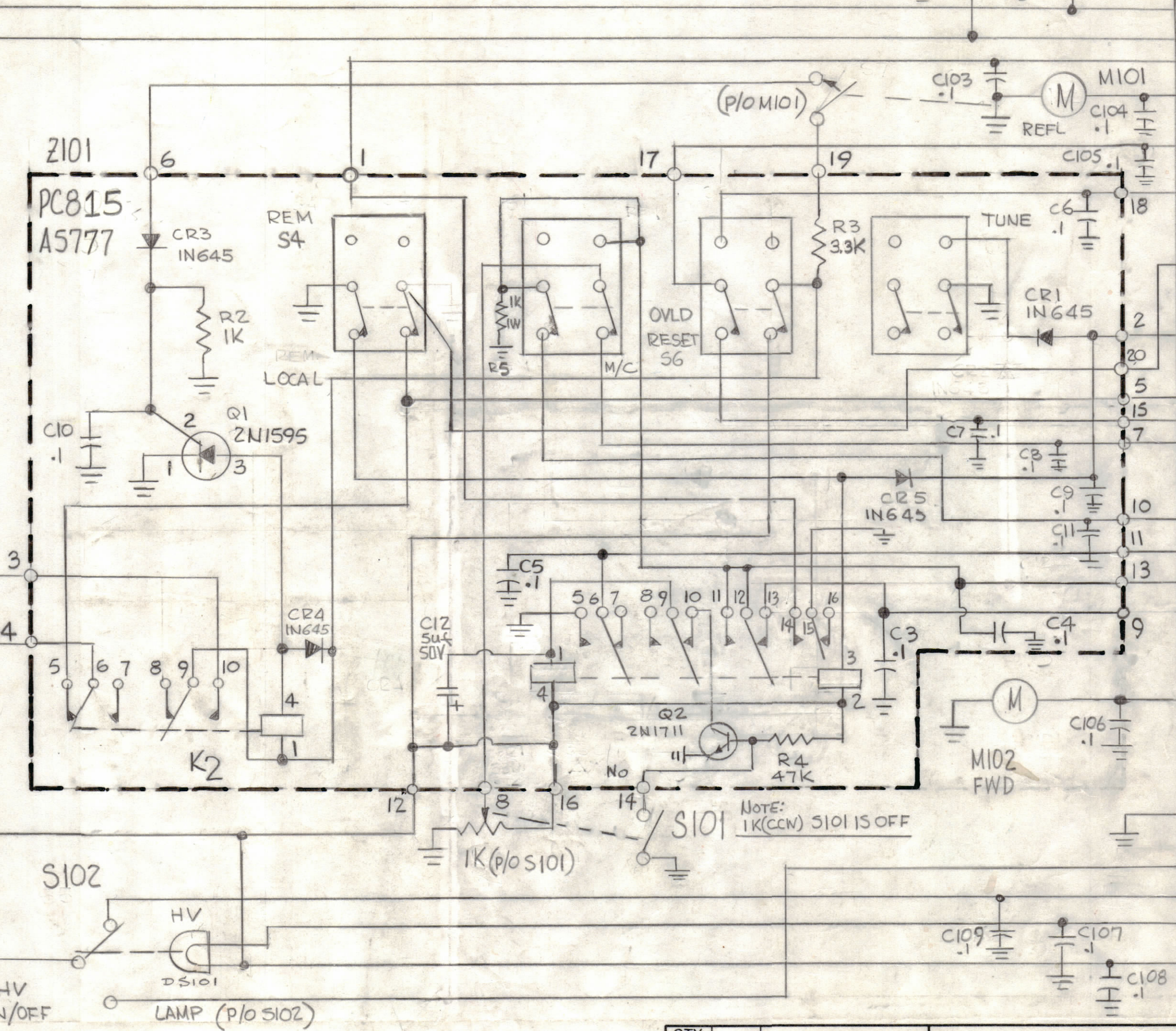
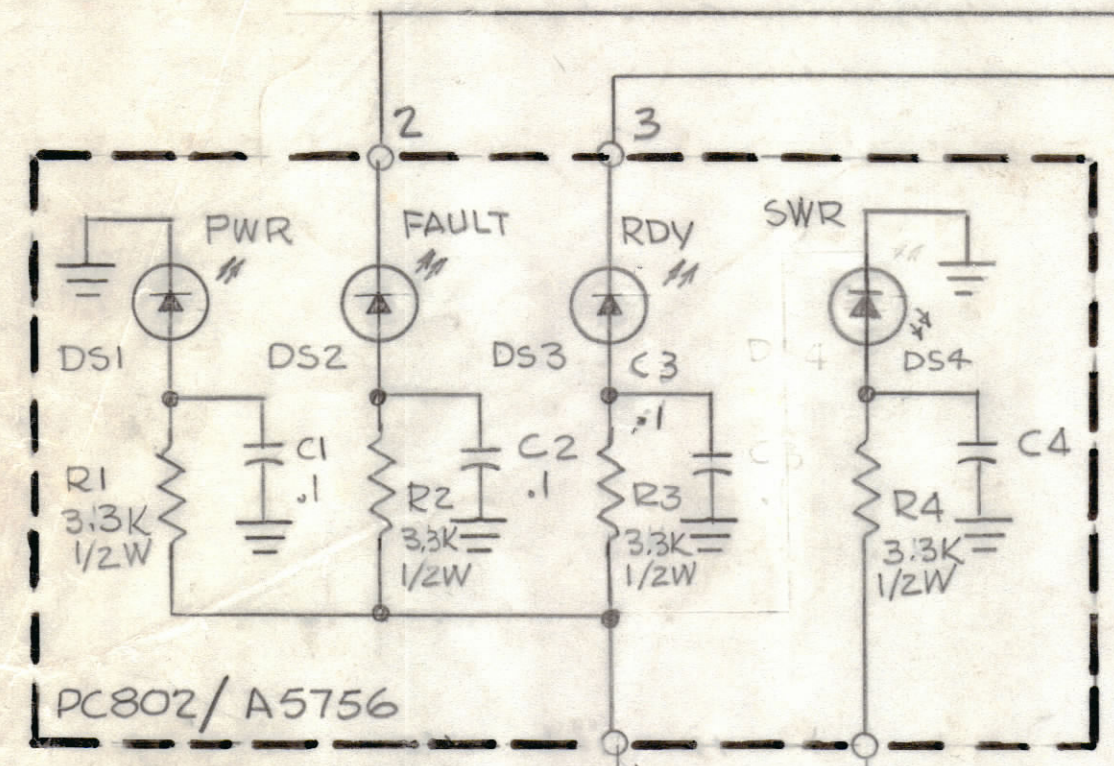

| TB101 | |
|-------|---------------------------|
| 9 | FAULT |
| 2 | READY |
| 16 | REM. METER CONT |
| 15 | REFL. PWR METER (XMITTER) |
| 19 | OVL D RES. |
| 10 | OVL D RESET |
| 21 | |
| 22 | HV ON/OFF |
| 1 | TUNE |
| 11 | HV ON |
| 20 | OVL D RESET |
| 12 | RF GAIN OUT M/C |
| 3 | RF GAIN IN M/C |
| 17 | ANT. SWTC |
| 13 | REMOTE GAIN (MMX) |
| 4 | FWD PWR METER (XMITTER) |
| 18 | GND |
| 7 | HV ON/OFF |
| 8 | HV IND |
| 5 | HV IND |
| 6 | +24V IN |

| QTY. REQ. | ITEM | PART NO. | DESCRIPTION | SYMBOL |
|--|-----------------|----------|-------------|--------|
| LIST OF MATERIAL | | | | |
| THE TECHNICAL MATERIEL CORP. MAMARONECK, NEW YORK | | | | |
| DIAGRAM, SCHEMATIC REMOTE (MFTA) | | | | |
| SIZE | CODE IDENT. NO. | DWG. NO. | ISSUE | |
| C | 82679 | CK2218 | B | |
| SCALE | SHEET | | | OF |

UNLESS OTHERWISE SPECIFIED DIMENSIONS ARE IN INCHES AND INCLUDE CHEMICALLY APPLIED OR PLATED FINISHES

TOLERANCES ON
 DECIMALS .X ± .05
 .XX ± .01
 .XXX ± .005
 FRACTIONS ± 1/64
 ANGLES ± 0° -30'

MATERIAL
 FINISH

| | |
|---|-------------------------|
| MFTA-10K/J | AX789-MFT |
| QTY / UNIT | MODEL USED ON ASS'Y NO. |
| APPLICATION | |
| CODE | |
| NOTICE TO PERSONS RECEIVING THIS DRAWING THE TECHNICAL MATERIEL CORPORATION claims proprietary right in the material disclosed hereon. This drawing is issued in confidence for engineering information only and may not be reproduced or used to manufacture anything shown hereon without permission from THE TECHNICAL MATERIEL CORPORATION to the user. This drawing is loaned for mutual assistance and is subject to recall at any time. | |



THE TECHNICAL MATERIEL CORPORATION

COMMUNICATIONS ENGINEERS

700 FENIMORE ROAD

MAMARONECK, N. Y.

Warranty

The Technical Materiel Corporation, hereinafter referred to as TMC, warrants the equipment (except electron tubes, *fuses, lamps, batteries and articles made of glass or other fragile or other expendable materials) purchased hereunder to be free from defect in materials and workmanship under normal use and service, when used for the purposes for which the same is designed, for a period of one year from the date of delivery F.O.B. factory. TMC further warrants that the equipment will perform in a manner equal to or better than published technical specifications as amended by any additions or corrections thereto accompanying the formal equipment offer.

TMC will replace or repair any such defective items, F.O.B. factory, which may fail within the stated warranty period, PROVIDED:

1. That any claim of defect under this warranty is made within sixty (60) days after discovery thereof and that inspection by TMC, if required, indicates the validity of such claim to TMC's satisfaction.
2. That the defect is not the result of damage incurred in shipment from or to the factory.
3. That the equipment has not been altered in any way either as to design or use whether by replacement parts not supplied or approved by TMC, or otherwise.
4. That any equipment or accessories furnished but not manufactured by TMC, or not of TMC design shall be subject only to such adjustments as TMC may obtain from the supplier thereof.

Electron tubes furnished by TMC, but manufactured by others, bear only the warranty given by such other manufacturers. Electron tube warranty claims should be made directly to the manufacturer of such tubes.

TMC's obligation under this warranty is limited to the repair or replacement of defective parts with the exceptions noted above.

At TMC's option any defective part or equipment which fails within the warranty period shall be returned to TMC's factory for inspection, properly packed with shipping charges prepaid. No parts or equipment shall be returned to TMC, unless a return authorization is issued by TMC.

No warranties, express or implied, other than those specifically set forth herein shall be applicable to any equipment manufactured or furnished by TMC and the foregoing warranty shall constitute the Buyers sole right and remedy. In no event does TMC assume any liability for consequential damages, or for loss, damage or expense directly or indirectly arising from the use of TMC Products, or any inability to use them either separately or in combination with other equipment or materials or from any other cause.

*Electron tubes also include semi-conductor devices.

TABLE OF CONTENTS

| PARA | | PAGE |
|---------------------|-------------------------------------|------|
| GENERAL INFORMATION | | |
| 1-1 | Description..... | 1-1 |
| 1-2 | Physical Description..... | 1-1 |
| 1-3 | Functional Description..... | 1-1 |
| | Controls and Indicator (Diagram) | 1-2 |
| | Rear Panel Identification (Diagram) | 1-3 |
| 1-4 | Operational Descriptions..... | 1-4 |
| OPERATION | | |
| 2-1 | Sequence of Operation..... | 2-1 |
| 2-2 | Tuning..... | 2-1 |
| 2-3 | Ready..... | 2-1 |
| 2-4 | RF Correction..... | 2-1 |
| | Overall Schematic (Diagram)..... | 2-3 |
| | System Interconnect..... | 2-6 |

GENERAL INFORMATION

1-1. DESCRIPTION

The AX789 remote unit is used to control certain critical functions of the MFT-10K/J Transmitter. Maximum location away from the transmitter should not exceed 100 feet. AX789 input information is connected at TB101, located at the rear of the unit (see figure 2). All inputs are wire connections. A +24 volt power source is supplied by the transmitter at Terminal 6 of TB101.

1-2. PHYSICAL DESCRIPTION

The AX789 remote unit is approximately 19 inches long, 4 inches deep and stands 5 inches high. The unit weight is approximately 4 and ½ pounds.

1-3. FUNCTIONAL DESCRIPTION

The following functions of the transmitter are controlled by the AX789 Remote Unit (see figure 1)

1. HIGH VOLTAGE ON
2. HIGH VOLTAGE OFF
3. TUNE
4. OVERLOAD RESET
5. SWR OVERLOAD ADJUSTMENT
6. RF GAIN

The following Readback functions are monitored on the front panel of the AX789 Remote Unit.

7. FAULT
8. READY
9. SWR OVERLOAD
10. HV ON
11. FORWARD POWER LEVEL
12. REFLECTED POWER LEVEL

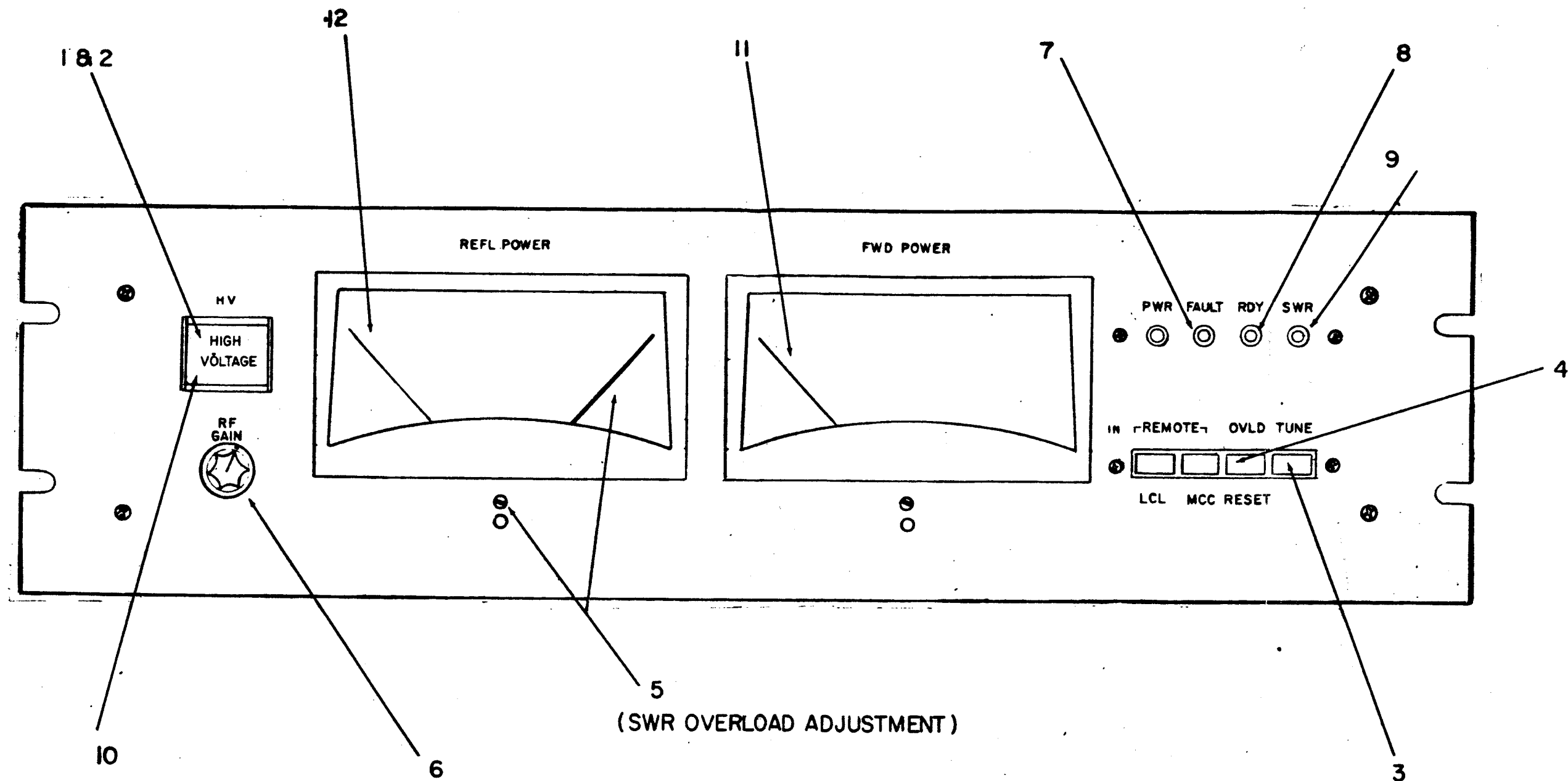

FIGURE I

CONTROLS and INDICATORS

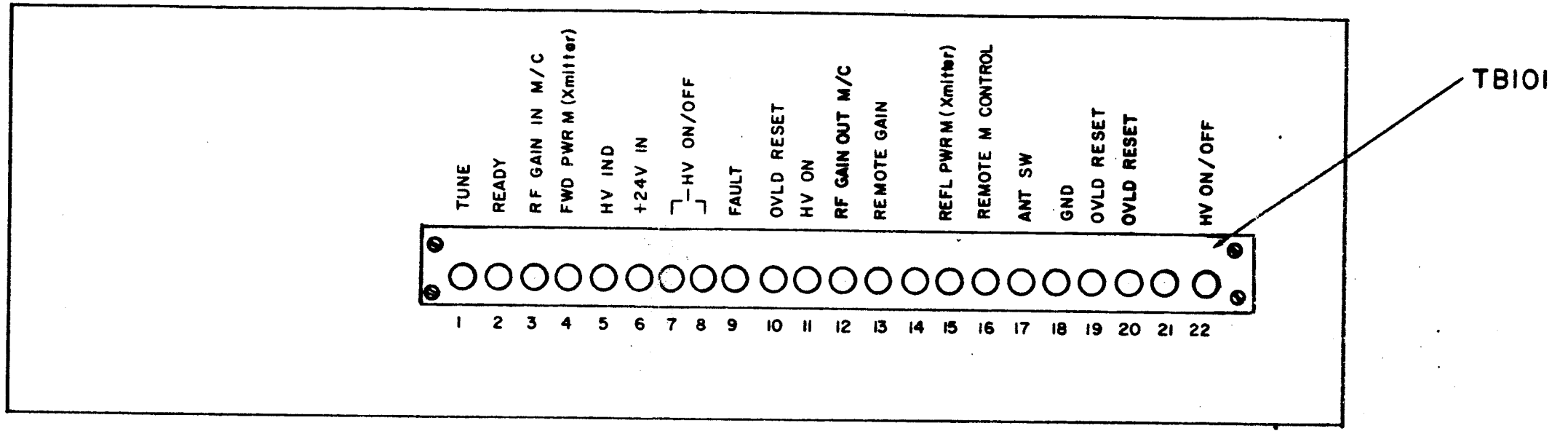
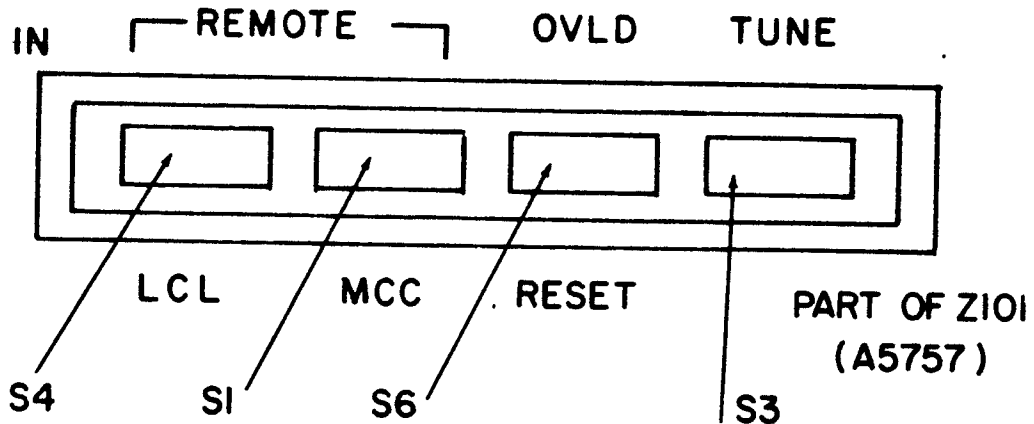

FIGURE 2

REAR PANEL IDENTIFICATION

1-4. OPERATIONAL DESCRIPTIONS

Symbol references used in the paragraphs to follow refer directly to figure 1 (Schematic diagram).



S4, REMOTE, LOCAL SWITCH

When normal, (outposition) control of the transmitter is at the transmitter site. When S4 is depressed control of the transmitter is transferred to the AX789 remote unit. NOTE: To accomplish this S1 must be depressed and the transmitter's High Voltage button must also be depressed. Now control is fully given to the AX789 remote unit.

S1, REMOTE, MISSION CONTROL SWITCH

This switch is used in conjunction with the mission control panel. It allows RF Gain Operation to be switched from the Remote unit AX789 to the mission control panel. This is accomplished by putting S1 in the normal position or out position.

S6, OVERLOAD RESET SWITCH

Depress approximately one second. This will facilitate a momentary closure. This in turn will reset any normal overload at the transmitter site. It will also reset SWR overload circuit on the AX789 Remote unit.

S3, TUNE SWITCH

Depress approximately one second. This will facilitate a momentary closure that will retune transmitter for automatic tuning.

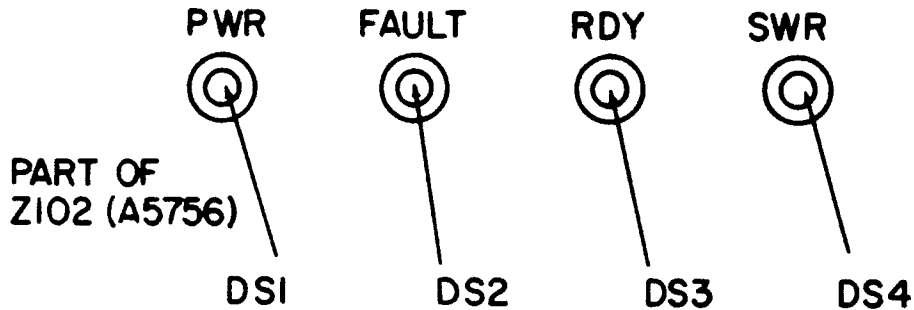

DS1 POWER LIGHT (PWR)

Led (Light Emitting Diode) will be lite when +24V is received from the transmitter.

DS2 FAULT LIGHT

Led will light when a fault in the transmitter's automatic tuning cycle occurs. (operates in automatic only)

DS3 READY LIGHT (RDY)

Led will light when the transmitter has completed it's automatic tuning cycle.

DS4 SWR OVERLOAD LIGHT

Led will light when SWR level exceeds red pointer meter adjustment. This overload is reset by depressing overload reset button.

S102 HIGH VOLTAGE ON/OFF SWITCH

The High Voltage button at the transmitter site must be depressed or (IN). The S102 switch at the AX789 remote unit will now control High Voltage ON or OFF.

When used in conjunction with the mission control panel S102 is operated as a 3 way switch. Therefore, HV ON/OFF can be controlled by either AX789 or mission control. If mission control panel is NOT used, it is necessary to Ground (GND) pin 7 of TB101.

S101 RF GAIN INTERLOCK SWITCH

This switch is used to switch A5757-K1 relay. The transmitter must be tuned and in the ready condition, before switching S101. When K1 Relay is initiated it will control Foward Meter (M102) and reflected meter M101 and also RF Gain functions, (see figure 3 and operation section).

SWR OVERLOAD ADJUSTMENT (p/o M101) see figure 1

This adjustment is made with a small flat head screwdriver at the M101 Reflected Power Meter face. Two holes are located below M101. The top hole is the adjustment. An adjustable set of contacts control the setting (red needle). This setting is normally made to trip at a SWR of 3:1.

M102 FOWARD POWER METER

After the automatic tuning cycle of the transmitter is complete, the M102 meter will moniter the foward power.

M101 REFLECTED POWER METER

After the automatic tuning cycle of the transmitter is complete, the M101 meter will monitor Reflected Power and SWR Overload.

OPERATION

2-1. SEQUENCE OF OPERATION

To operate the AX789 Remote unit, it will be necessary to have initiated the following control settings:

A. At the Transmitter site, the Automatic-Manual switch turned to Automatic. The High Voltage Switch turned ON.

B. At the AX789 unit, the Remote switch LCL(S4) depressed. The Remote switch MCC(S1) depressed. The RF Gain knob (S101) turned clockwise. Note it is important that S101 be turned counter-clockwise, but not switched OFF. If this is not done the AX789 remote unit will not function.

2-2. TUNING

After the desired exciter frequency is set, the High Voltage switch (S102) should be turned ON, now we are ready for tuning. Carefully drive transmitter from 1 amp IDLE current to 2 amps (tune level). Plate current is monitored at remote, with external plate current meter. After transmitter tunes and goes to RDY, S101 is adjusted fully counter-clockwise to engage OFF switch. This will then switch over meters M101 and M102 for remote monitoring. RF gain is now adjusted for proper output level for tuning of antenna tuner. Depress the tune switch (S3), the transmitter should start tuning automatically and go to a ready condition. Note that the meters M101 and M102 will not be reading during the tuning up of the transmitter, but the meters at the transmitter will read.

2-3. READY

The transmitter should now be in a ready condition and be putting out 2-3 KW RF into a dummy load. RF is now ready to be switched to an Antenna Tuner. This is accomplished by rotating the RF GAIN knob (S101) fully counter-clockwise or OFF. Turning (S101) fully counter-clockwise will initiate A5757-K1 relay. This will switch in Meters M101, M102, and the RF Gain Control. A5757-K1 relay will also ground (GND) pin 17 of TB101, which will activate the antenna tuner.

2-4. RF CORRECTION

The transmitter can now be manually driven up to correct tuning at the 1-2 KW level, for final antenna tuner set-up (min SWR).

When the antenna tuner has been properly tuned, the transmitter can be driven up to full RF OUTPUT POWER. The control of the RF Gain now can be switched from the AX789 Remote unit mission control by releasing remote switch MCC(S1).

| Part Number | Description | Used On | Qty | Symbol Number |
|-------------|-------------------|---------|-----|--|
| A5756 | ASSY, PC BD IND | AX789 | 1 | Z102 |
| A5777 | ASSY, PC BD SW | AX789 | 1 | Z101 |
| BI110-7. | LAMP, INCAN | AX789 | 1 | DS101 |
| CC100-28 | CAP, FXD, CER | AX789 | 9 | C101,C102,C103,C104, C105,C106,C107,C108, C109 |
| MR239 | METER, KW OUTPUT | AX789 | 1 | M102 |
| MR238 | METER, REF PWR | AX789 | 1 | M101 |
| RV4NBYS102B | RESISTOR, VAR, SW | AX789 | 1 | S101 |
| SW522-1 | SWITCH, PUSH | AX789 | 1 | S102 |
| TM100-22 | TERMINAL STRIP | AX789 | 1 | TB101 |

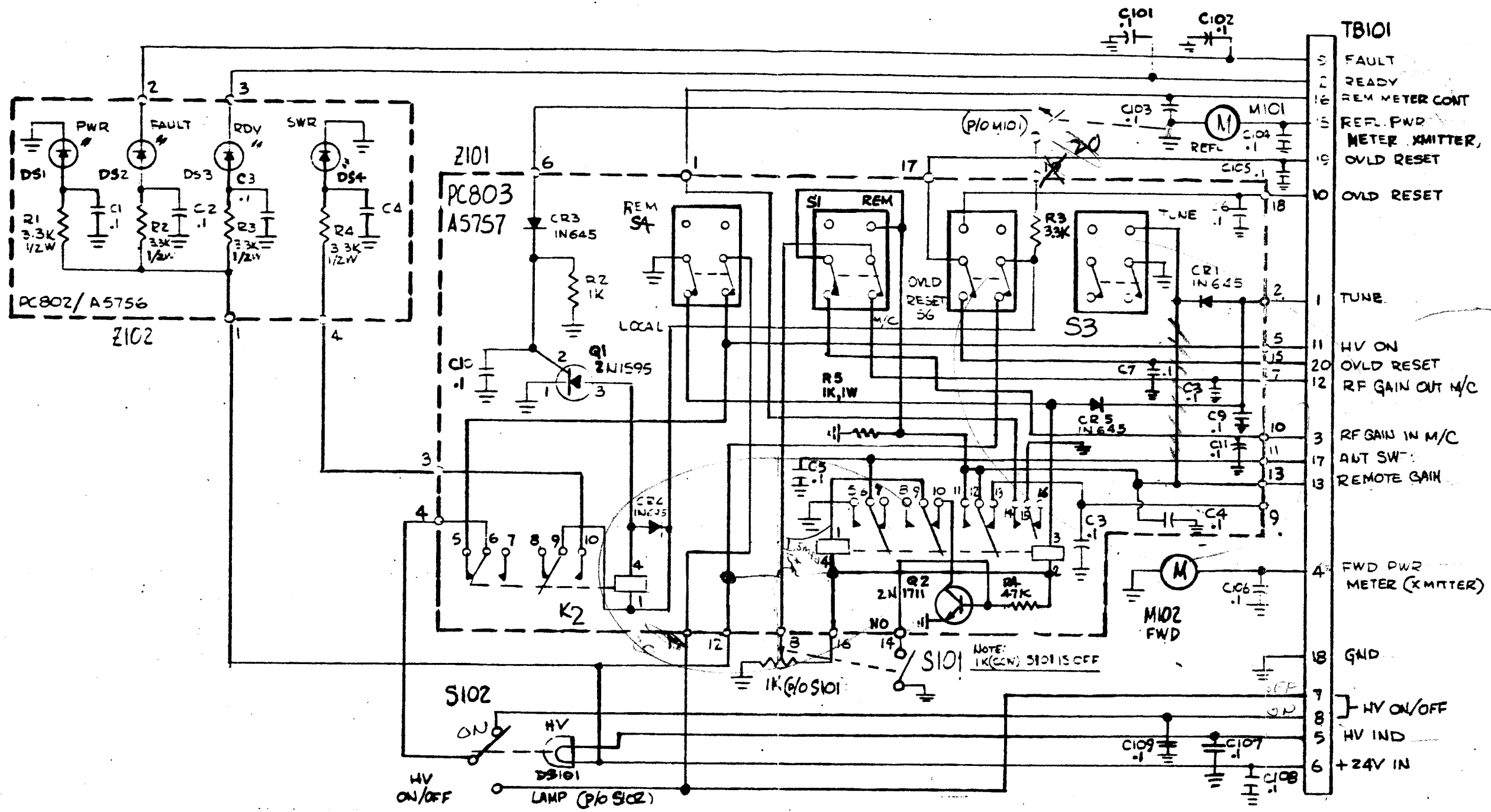

CK2218-β

FIGURE 3

OVERALL SCHEMATIC DIAGRAM

| Part Number | Description | Used On | Qty | Symbol Number |
|-------------|---------------|---------|-----|----------------------------------|
| CC100-28 | CAP, FXD, CER | A5777 | 9 | C3,C4,C5,C6,C7,C8,C9, C10,C11 |
| RC07GF102J | RES, FXD | A5777 | 1 | R2 |
| RC07GF332J | RES, FXD | A5777 | 1 | R3 |
| RC32GF102J | RES, FXD | A5777 | 1 | R5 |
| RC07GF473J | RES, FXD | A5777 | 1 | R4 |
| RL156-10 | REL ARM | A5777 | 1 | K1 |
| RL156-19 | REL ARM | A5777 | 1 | K2 |
| SW559-N-1 | SW PB | A5777 | 2 | S3,S6 |
| SW559-P-1 | SW PB | A5777 | 2 | S1,S4 |
| TS171-4 | SKT, RELAY | A5777 | 1 | XK1 |
| TS171-5 | SKT, RELAY | A5777 | 1 | XK2 |
| 1N645 | DIODE | A5777 | 4 | CR1,CR3,CR4,CR5 |
| 2N1595 | TRANSISTOR | A5777 | 1 | Q1 |
| 2N1711 | TRANSISTOR | A5777 | 1 | Q2 |

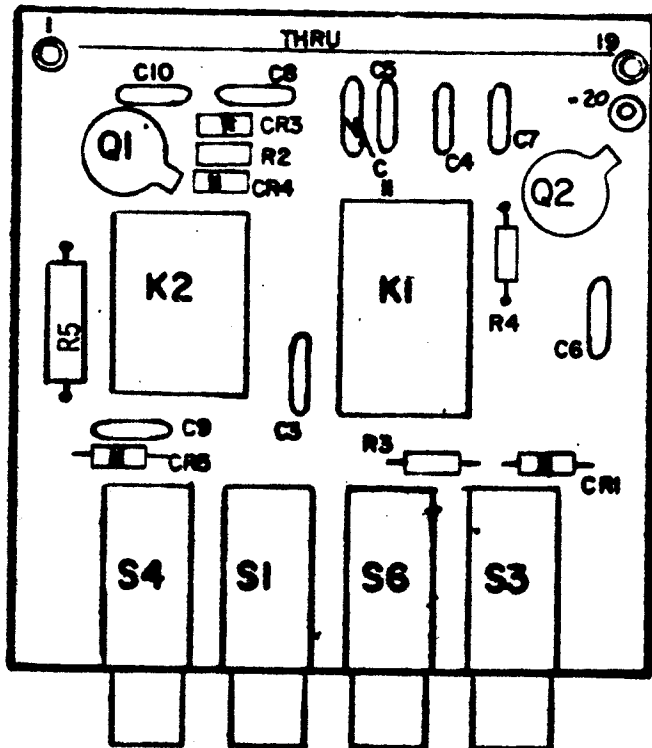

**CONTROL ASSEMBLY
A5757(Z101)**

| PART NUMBER | DESCRIPTION | USED ON ASSEMBLY | QTY PER UNIT | REFERENCE SYMBOLS |
|-------------|----------------|------------------|--------------|--------------------|
| EI132 | LED | A5756 | 4 | DS1, DS2, DS3, DS4 |
| CC100-28 | CAP, FXD, CER | A5756 | 4 | C1, C2, C3, C4 |
| RC20GF332 | RES, FXD, COMP | A5756 | 4 | R1, R2, R3, R4 |

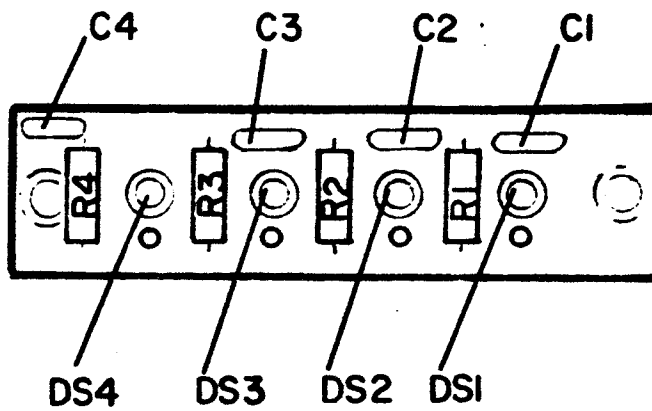

INDICATOR ASSEMBLY
A5756 (Z102)