

★  
PART VII OF VOLUME II

AUXILIARY FRAME ASSEMBLY  
AX-180, E/W METER PANEL AX-107,  
SIDEBAND LEVEL MONITOR  
SLM-1 OR -2, MONITOR CONTROL  
PANEL MCP-1 OR -2, ISOLATION  
KEYER AK-100, AND AUXILIARY  
POWER PANEL APP-1



THE TECHNICAL MATERIEL CORPORATION

MAMARONECK, N. Y.

OTTAWA, CANADA

★

★  
PART VII OF VOLUME II

AUXILIARY FRAME ASSEMBLY  
AX-180, E/W METER PANEL AX-107,  
SIDEBAND LEVEL MONITOR  
SLM-1 OR -2, MONITOR CONTROL  
PANEL MCP-1 OR -2, ISOLATION  
KEYER AK-100, AND AUXILIARY  
POWER PANEL APP-1

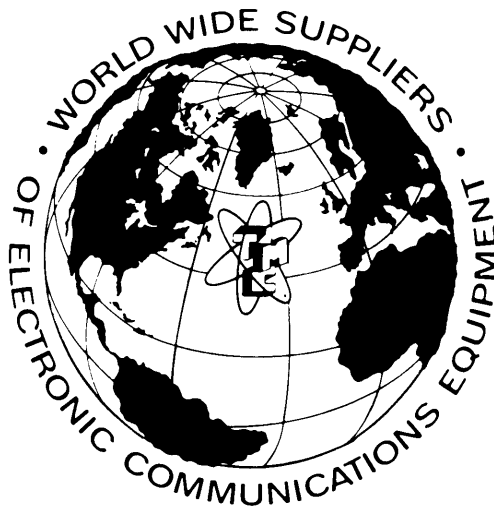

THE TECHNICAL MATERIEL CORPORATION  
MAMARONECK, N. Y.

OTTAWA, CANADA

★  
Issue Date: 1 March 1962

## TABLE OF CONTENTS FOR PART VII OF VOLUME II

<b>SECTION 1 — GENERAL DESCRIPTION</b>		<b>SECTION 5 — TROUBLE-SHOOTING (Cont.)</b>	
Paragraph	Page	Paragraph	Page
7-1-1	1-1		
<b>SECTION 2—INSTALLATION</b>			
	2-0		
<b>SECTION 3—OPERATOR'S SECTION</b>			
7-3-1	3-1		
7-3-2	3-1		
a.	3-1		
b.	3-1		
c.	3-3		
<b>SECTION 4—PRINCIPLES OF OPERATION</b>			
7-4-1	4-0		
7-4-2	4-0		
a.	4-0		
b.	4-0		
c.	4-0		
d.	4-0		
e.	4-1		
f.	4-1		
<b>SECTION 5 — TROUBLE-SHOOTING</b>			
7-5-1	5-1		
7-5-2	5-1		
7-5-3	5-1		
a.	5-1		
b.	5-1		
		c.	5-1
		d.	5-1
		<b>SECTION 6—MAINTENANCE</b>	
		7-6-1	6-0
		7-6-2	6-0
		7-6-3	6-0
		7-6-4	6-0
		a.	6-0
		b.	6-0
		c.	6-0
		d.	6-0
		7-6-5	6-0
		7-6-6	6-0
		a.	6-0
		b.	6-1
		c.	6-1
		d.	6-2
		7-6-7	6-2
		a.	6-2
		b.	6-2
		c.	6-2
		<b>SECTION 7 — PARTS LIST</b>	
			7-1

## LIST OF ILLUSTRATIONS FOR PART VII OF VOLUME II

Figure	Title	Page
II-7-4-1.	Interconnection Wiring Between Meter Panel (AX-107) and GPT-10K's PA Section . . . . .	4-2
II-7-4-2.	Block Diagram, SLM-1 and SLM-2 . . . . .	4-3
II-7-4-3.	Schematic Diagram (2 sheets), SLM-1 and SLM-2 . . . . .	4-4
II-7-4-4.	Schematic Diagram (2 sheets), MCP-1 and MCP-2 . . . . .	4-7—4-8
II-7-4-5.	Schematic Diagram, ISK . . . . .	4-11—4-12
II-7-4-6.	Partial Wiring Diagram, Auxiliary Frame Chassis for Non-Synthesized GPT-10K . . . . .	4-13
II-7-4-7.	Wiring Diagram, APP-1 . . . . .	4-14
II-7-4-8.	Wiring Diagram, Auxiliary Frame Chassis for Non-Synthesized GPT-10K Equipped With MCP-2 Unit . . . . .	4-15—4-16

## LIST OF TABLES FOR PART VII OF VOLUME II

Table		Page
II-7-5-1	Voltage and Resistance Chart, Sideband Level Monitor SLM-1 . . . . .	5-1
II-7-5-2	Voltage and Resistance Chart, Sideband Level Monitor SLM-2 . . . . .	5-2
II-7-5-3	Voltage and Resistance Chart, Isolation Keyer AK-100 . . . . .	5-3

**PART VII-AUXILIARY FRAME ASSEMBLY E/W  
NON-REMOVABLE EQUIPMENT UNITS**

**SECTION 1  
GENERAL DESCRIPTION**

**1-1. GENERAL.**

Refer to the following illustrations in companion manual (Volume I) for pictorial information relative to the auxiliary frame assembly:

I-1-1-a. Front View, Model GPT-10K (Non-Synthesized).

I-1-2-a. Isometric Drawing, Model GPT-10K (Non-Synthesized).

I-2-3. Auxiliary Frame Chassis (fully assembled for shipping).

Refer to Part I of this manual (Volume II) for general description of test and exciter frame equipment. The proper control, operation, and test procedures for a sideband transmitter require the services of auxiliary equipment as described in this part of the manual. Part VII of this manual describes operational, theory, trouble-shooting, maintenance, parts list and other information relative to the Auxiliary Frame Assembly.

**SECTION 2  
INSTALLATION**

Refer to companion manual (Volume I) Section 2 for details.



## SECTION 3

### OPERATOR'S SECTION

#### 3-1. UNITS IN REMOVABLE DRAWERS IN AX-180.

These units comprise the FSA, SBE, VOX, XFK, and TTG; they are operationally described respectively in Parts II through VI (Volume II) of this manual.

#### 3-2. NON-REMOVABLE UNITS IN AX-180.

These units comprise the meter panel (AX-107), the Sideband Level Monitor Unit SLM-1 or -2, Monitor Control Panel MCP-1 or -2, Isolation Keyer AK-100, and the Auxiliary Power Panel APP-1. There are no operating controls on the AX-107 and the APP-1.

a. **SIDEBAND LEVEL MONITOR SLM-1 OR SLM-2.** - The SLM-1 is associated with an SBE-2 and indicates 17-kc sideband levels in the LSB/USB filter outputs; the SLM-2 is associated with an SBE-3 and indicates 250-kc sideband levels in the LSB/USB filter outputs.

Operation of the ON-OFF toggle switch provides the SLM-1 or SLM-2 with filament and plate voltages. An indicator lamp indicates power supply. LSB and USB meters indicate levels. Screwdrive-type potentiometers provide means of calibrating the meters. The front panel also contains two fuses.

(1) **GENERAL INSTRUCTIONS APPLICABLE TO SLM-2.** - The SLM-2 consists essentially of two 250-kc amplifiers; the output of each contains a VTVM. These meters monitor the sideband levels of an associated SBE-3's 250-kc balanced modulator. Good operating practice is to keep the indicated levels below 0 db, and preferably around -19 db. These levels are of course a function of SBE-3's audio inputs; these levels too should be limited to 0 db and should preferably be kept around -10 db.

While the SBE-3's output meter may be used to limit the SBE-3's audio input properly, and consequently its 250-kc balanced modulator's upper/lower sideband levels, the SLM's meters provide a convenient means of continuously monitoring the sideband levels while permitting SBE-3's output meter to monitor other quantities essential to the good operation of a GPT-10K.

(2) **GENERAL INSTRUCTIONS APPLICABLE TO SLM-1.** - The SLM-1 consists essentially of two 17-kc amplifiers; the output of each contains a VTVM. These meters monitor the sideband levels of an associated SBE-2's 17-kc balanced modulator. Good operating

practice is to keep the indicated levels below 0 db, and preferably around -10 db. These levels are of course a function of SBE-2's audio inputs; these levels too should be limited to 0 db and should preferably be kept around -10 db.

While the SBE-2's output meter may be used to limit the SBE-2's audio input properly, and consequently its 17-kc balanced modulator's upper/lower sideband levels, the SLM's meters provide a convenient means of continuously monitoring the sideband levels while permitting SBE-2's output meter to monitor other quantities essential to the good operation of a GPT-10K.

(3) **CALIBRATION APPLICABLE TO SLM-2.** - The SLM-2's CALIBRATE potentiometers, USB and LSB, should be set so that SLM-2's VTVMs track the associated SBE-3's output meter. On this basis, SLM's VTVMs read SBE-3's audio input levels rather than the SBE-3's 250-kc balanced modulator sideband levels. The difference is of no practical importance.

(4) **CALIBRATION APPLICABLE TO SLM-1.** - The SLM-1's CALIBRATE potentiometers, USB and LSB, should be set so that SLM-1's VTVMs track the associated SBE-2's output meter. On this basis, SLM's VTVMs read SBE-2's audio input levels rather than the SBE-2's 17-kc balanced modulator sideband levels. The difference is of no practical importance.

(5) **OPERATION APPLICABLE TO SLM-2.** - Since the SLM-2 is a VTVM, operation is automatic provided the input circuits are connected to a 250-kc signal source and the meter is powered.

(6) **OPERATION APPLICABLE TO SLM-1.** - Since the SLM-1 is a VTVM, operation is automatic provided the input circuits are connected to a 17-kc signal source and the meter is powered.

b. **MONITOR CONTROL PANEL MCP-1 OR MCP-2.** - The MCP-1 is associated with earlier GPT-10K models, namely, those without an isolation keyer (AK-100); the MCP-2 is associated with later GPT-10K models, namely, those containing an isolation keyer (AK-100). The MODE SELECTOR switch on the MCP-2 provides switching between CW, TTY, or FAX equipment and XFK, SBE units via AK-100.

The MCP's are a switching assembly to facilitate meter connection of a number of GPT-10K circuits for test or excitation purposes. Operating instructions are as follows:

Panel Designation	Operation	Result
CHANNEL 2	TONE INPUT	Connects TTG's audio tones to SBE's channel 2.
	LINE 2 INPUT	Connects audio signals on incoming line 2 to SBE's channel 2.
CHANNEL 1	TONE INPUT	Connects TTG's audio tones to SBE's channel 1.
	LINE 1 INPUT	Connects audio signals on incoming line 1 to SBE's channel 1.
ANALYZER MONITOR	TEST	Connects TTG's RF tones to FSA.
	SBE	Connects SBE's RF output to FSA.
	DRIVER	Connects IPA's RF output to FSA.
	FINAL	Connects PA's RF output to FSA.
VOX RF OUTPUT	EXT	Connects VOX's OUT SIGNAL to GPT-10K's jack J3005.
	SBE	Connects VOX's OUT SIGNAL to SBE's via SBE VMO INPUT switch 108 position VOX. VMO IN jack J104 via MCP's switch 108 in VOX position.
	ANALYZER	Connects VOX's OUT SIGNAL to FSA.
	XFK	Connects VOX's OUT SIGNAL to XFK.
SBE VMO INPUT	EXT	Connects an external VMO to SBE via GPT-10K's jack J3004.
	OFF	Open connection.
	XFK	Connects XFK's RF frequency-shift signal to SBE.
	VOX	Connects VOX's RF signal to SBE's (2- to 4-mc modulator) VMO IN jack J104 via MCP's switch 109 in SBE position.
MODE	Position 1	SSB signals on LINE 1 and LINE 2 terminals (TB 3002) of Auxiliary Frame terminal board are directed to the SBE chan 1 and chan 2 terminals (TB E101).
	Position 2	Cw key connected to terminals 23 and 24 of TB E3002 of Auxiliary Frame terminal board creates cw by enabling/disabling SBE's RF output circuit.

Panel Designation	Operation	Result
	Position 3	Cw key connected between terminals 7 and 8 of TB E1 of XFK creates cw via XFK and SBE.
	Position 4	RATT signals to terminals 5 and 6 of TB E3000 of Auxiliary Frame terminal board creates FSK signals via MCP, ISK, XFK, and SBE.
	Position 5	FAX signals to terminal 16 of TB E3001 of Auxiliary Frame terminal board creates FAX signals via XFK and SBE.

c. ISOLATION KEYER AK-100. - The isolation keyer is equipped with a keying mode selector switch, a main power supply switch, six fuses (three spare), an indicator, a screwdriver-type potentiometer (threshold adjust), and a screwdriver-type potentiometer (voltage adjust). General and operating instructions are as follows:

(1) GENERAL INSTRUCTIONS. - The ISK is factory adjusted so that continuous space-mark incoming signals will enable and disable the keyer's oscillator, thus making the outgoing signals a replica of the incoming signals. An oscilloscope on the keyer's output will show that this condition is fulfilled by positioning the THRESHOLD potentiometer close to mid-range. If a keyer fails to drive its GPT-10K properly, the operator should adjust the THRESHOLD potentiometer over a small sector around its mid-range.

If the keyer still fails to drive the GPT-10K properly, the operator should consult a more experienced technician.

(2) OPERATING INSTRUCTIONS.

- (a) Turn MAIN power switch to ON.
- (b) Turn MODE switch to its proper position for type of incoming signals.
- (c) Adjust VOLT ADJ potentiometer for proper output signal voltages.
- (d) Adjust THRESHOLD potentiometer a little on either side of mid-range as required to obtain signals as explained above.



## SECTION 4 PRINCIPLES OF OPERATION

### 4-1. UNITS IN REMOVABLE DRAWERS IN AX-180.

These units comprise the FSA, SBE, VOX, XFK, and TTG; they are described stage-by-stage, respectively, in Parts II through VI (Volume II) of the manual.

### 4-2. NON-REMOVABLE UNITS IN AX-180.

These units comprise the Meter Panel (AX-107), the Sideband Level Monitor Unit SLM-1 or -2, Monitor Control Panel MCP-1 or -2, Isolation Keyer AK-100, and the Auxiliary Power Panel APP-1.

a. **METER PANEL AX-107.** - Figure II-7-4-1 shows interconnection wiring between the three meters on AX-107 and components in the PA section of GPT-10K.

b. **SIDEBAND LEVEL MONITOR UNIT SLM-1 OR SLM-2.** - Figure II-7-4-2 is a block diagram of these units; figure II-7-4-3 (sheets 1 and 2) are simplified schematics of these units.

(1) As shown in figure II-7-4-2, the SLMs consist of a lower sideband level VTVM circuit, an upper sideband level VTVM circuit, and a power supply circuit. Electrically, the SLM-2 monitors the sideband levels of an associated SBE-3's 250-kc balanced modulator, and the SLM-1 monitors the sideband levels of an associated SBE-2's 17-kc balanced modulator. In order to avoid appreciable distortion, the SLMs should not be operated to give peak meter deflections exceeding 100.

(2) As shown in figure II-7-4-3, each SLM contains a pentode (first stage) and a triode (second stage). The SLM-2 is essentially an RF amplifier VTVM with its pentode's plate tuned to 250 kc. Its regulated power supply is 105 volts (OB2). The SLM-1 is essentially a low-frequency amplifier VTVM without plate tuning. Consequently, it has a relatively flat transmission characteristic. Its regulated power supply is 150 volts (OA2).

c. **MONITOR CONTROL PANEL MCP-1 OR MCP-2.** - (See figure II-7-4-4, 2 sheets).

(1) **SWITCH S300 - CHANNEL 2.** - Depending upon the position of S300, incoming TTG audio tone signals or audio signals on telephone/telegraph line 2 reach SBE channel 2.

(2) **SWITCH S301 - CHANNEL 1.** - Depending upon the position of S301, incoming TTG audio tone signals or audio signals on telephone/telegraph line 1 reach SBE channel 1.

(3) **SWITCH S302 - ANALYZER MONITOR.** - FSA is wired for four RF signal sources, namely, TG, output of SBE, output of IPA (DRIVER), and output of PA.

(4) **SWITCH S303 - VOX RF OUTPUT.** - VOX's output may be fed to four inputs, namely, external injection jack J15 of XFK, VFO INPUT jack J102 of FSA, VMO in jack J104 of SBE, and EXTERNAL VOX OUTPUT jack J3005 located on the center shield panel assembly which is mounted on the auxiliary frame chassis. For XFK and SBE service, the HFO output of VOX is restricted to the 2- to 4-mc band; for FSA and external RF supply service, the HFO output of VOX may be anywhere within the 2- to 32-mc band.

(5) **SWITCH S304 - SBE VMO INPUT.** - The SBE is wired for three external 2- to 4-mc signal sources, namely, VOX, XFK, and a VMO connected to EXTERNAL VMO jack J3004 located on the center shield panel assembly which is mounted on the auxiliary frame chassis.

(6) **SWITCH S305 - MODE.** - MCP-1 is like MCP-1 except for the addition of the MODE switch. As shown by the wiring diagram, figure II-7-4-6, signals of various types are routed via the MODE switch as follows:

- (a) SSB signals are directed to the SBE.
- (b) CW signals are directed either to the SBE or XFK.
- (c) RTTY signals are directed to the XFK.
- (d) FAX signals are directed to the XFK.

In cases (b) and (c), the telegraph signals are routed through an isolation keyer interposed between the CW and RTTY keying equipments.

d. **ISOLATION KEYER AK-100** (See figure II-7-4-5). - The ISK is an electronic keyer that functionally replaces the well-known relay keyer in RATT lines at transmitter sites. In figure II-7-4-5, terminal E4001, pins 1 and 2, receive teletype mark-space signals or CW dot-dash signals. The path of the signals from their source to E4001 is shown in figure II-7-4-6.

Assume a specific case where 60 marks and 60 spaces per second (corresponding to 60-dot cycles or 240 words per minute) are being received at E4001; the square shape voltage wave having a 50-volt amplitude. In this case, KEYING MODE switch S4001 is turned to position 1 and the 50 volts dissipates itself across voltage divider R4006 and R4004.

V5001B is an oscillator (15 to 18 kc) which is excited or cut off according to the "blocking action" of V5001A. On reception of "marks," V4001A disables V4001B, stopping oscillation; on reception of "spaces," V4001A is cut off allowing V4001B to oscillate freely.

Action at V4002A and V4002B is as follows: On reception of "marks," the negative bias at V4002A is removed and V4002B conducts; on reception of "spaces," the negative bias appears at V4002A and V4002B is cut off.

The output of the ISK on RATT operation is at E4001, pins 4 and 5. R4014 provides voltage at these pins during "marks" and no voltage during "spaces." The output of the ISK on CW operation is at E4001, pins 8 and 10. Relay K4001 connects pins 8 and 10 on "marks" and disconnects pins 8 and 10 on "spaces."

Keying mode switch S4001 enables the ISK to function properly on four types of key-line reception:

<u>Position</u>	<u>Keying Mode</u>
1	50 volts
2	100 volts
3	60 ma (neutral)
4	20 ma (polar)

Threshold adjust potentiometer R4011 should be set to trigger oscillator V4001B on and off coincidentally with incoming "space" and "mark" signals, respectively. As pointed out in Section 6, comparison of incoming and outgoing waveforms, at E4001, pins 1 and 2 versus 4 and 5 or 8 and 10, on an oscilloscope, is a convenient and practical marker to determine the optimum setting of R4011.

Voltage adjust potentiometer R4014 should be set to furnish the proper magnitudes of "space" and "mark" signals.

e. AUXILIARY POWER PANEL APP-1 (See figure II-7-4-7). - The auxiliary power panel contains four polarized convenience outlets, mounted on the front panel. An U-shaped bracket, mounted on the rear of the front panel houses a fifth polarized convenience outlet.

f. AUXILIARY FRAME CHASSIS AX-180 (See figure II-7-4-8). - Refer to figure I-2-3 in companion manual (Volume I). The units described in preceding paragraphs a through e are removed from the chassis, and electrical components only are considered, figure II-7-4-8 shows the end result. The chassis is energized by single-phase 230 volts from phase 2, 3 of incoming three-phase power. The main electrical components are filters, circuit breaker, sola regulating transformer, eight 115-volt outlets, front fan and indicating lamp. Their use is conventional and requires no explanation.

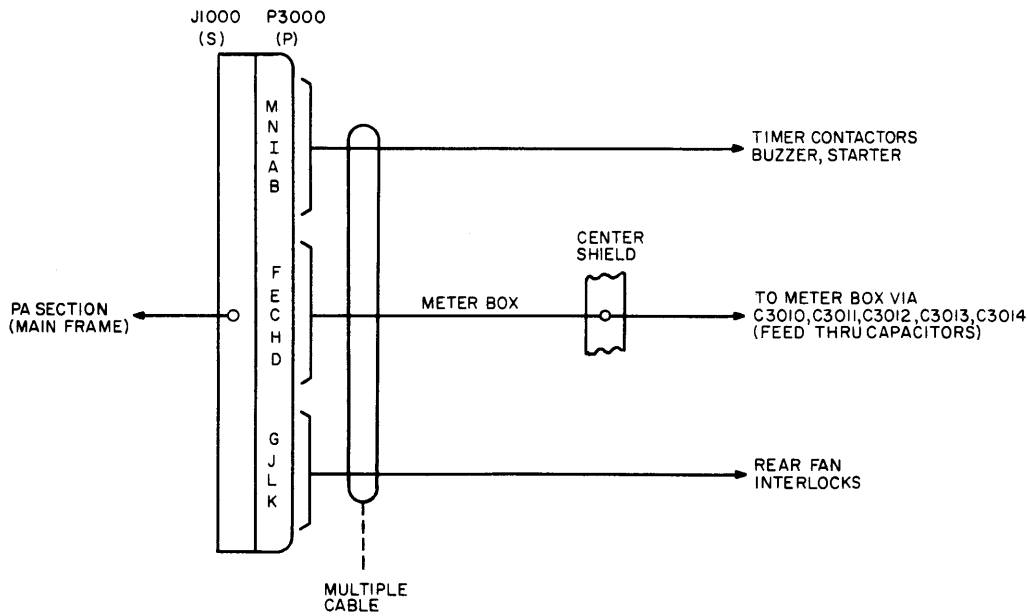
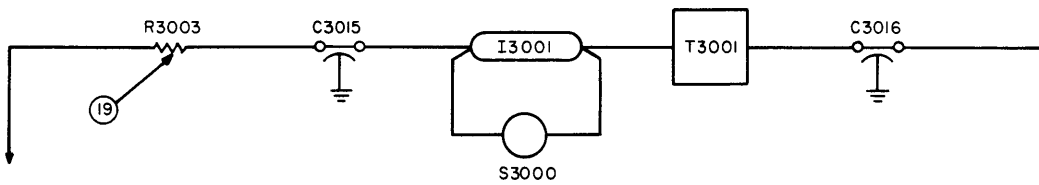
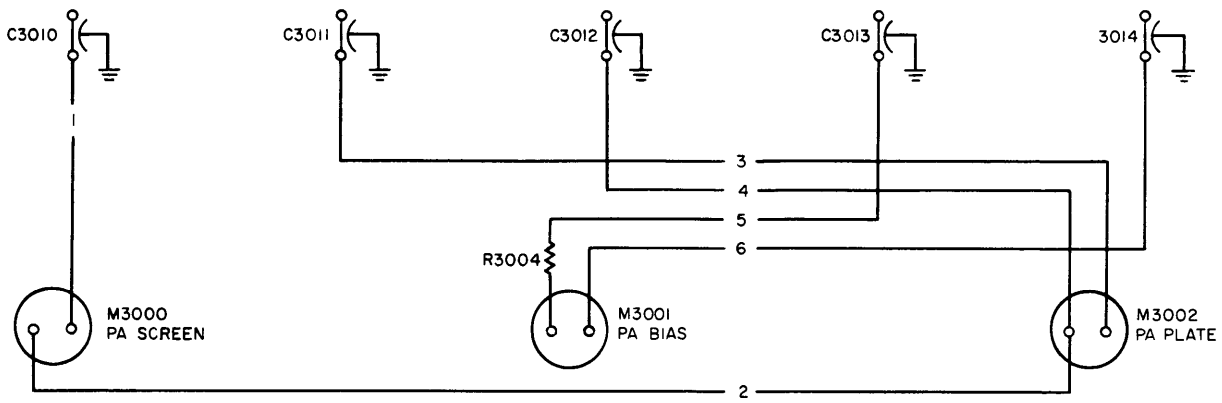
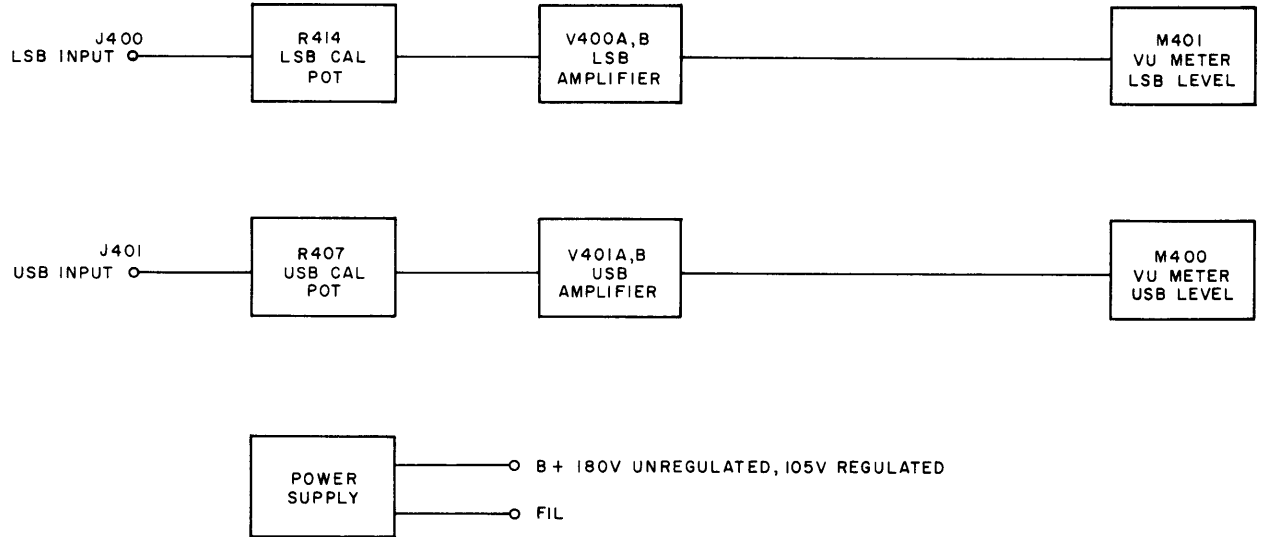
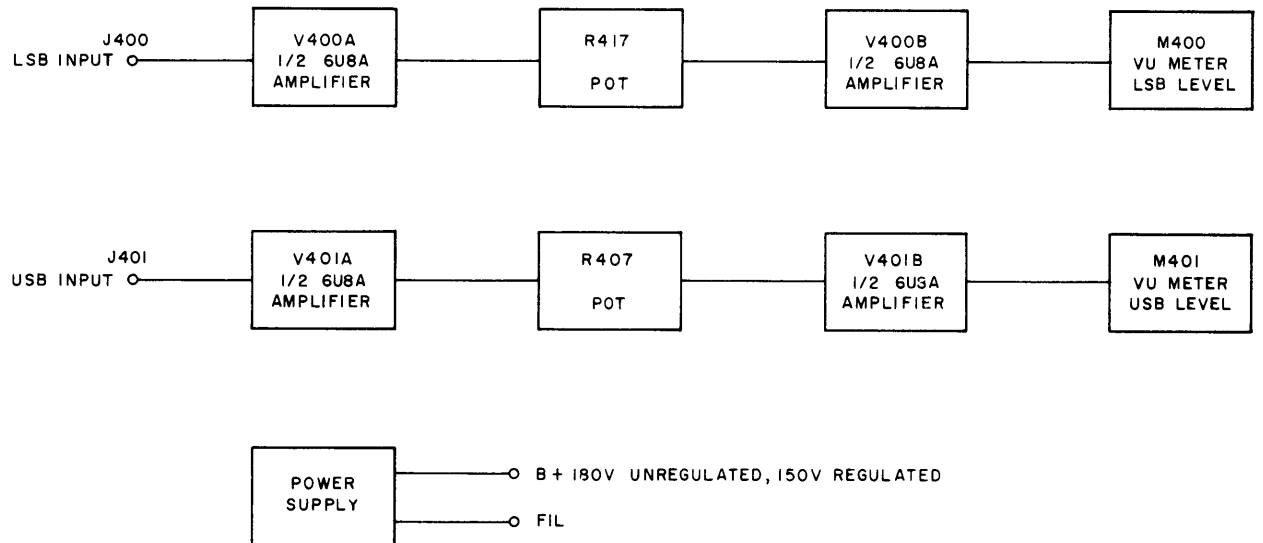

Figure II-7-4-1. Interconnection Wiring Between Meter Panel (AX-107) and GPT-10K's PA Section



SKETCH 1 BLOCK DIAGRAM, SIDEBAND LEVEL MONITOR MODEL SLM-2



SKETCH 2 BLOCK DIAGRAM, SIDEBAND LEVEL MONITOR MODEL SLM-1

Figure II-7-4-2. Block Diagram, SLM-1 and SLM-2

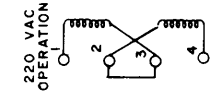
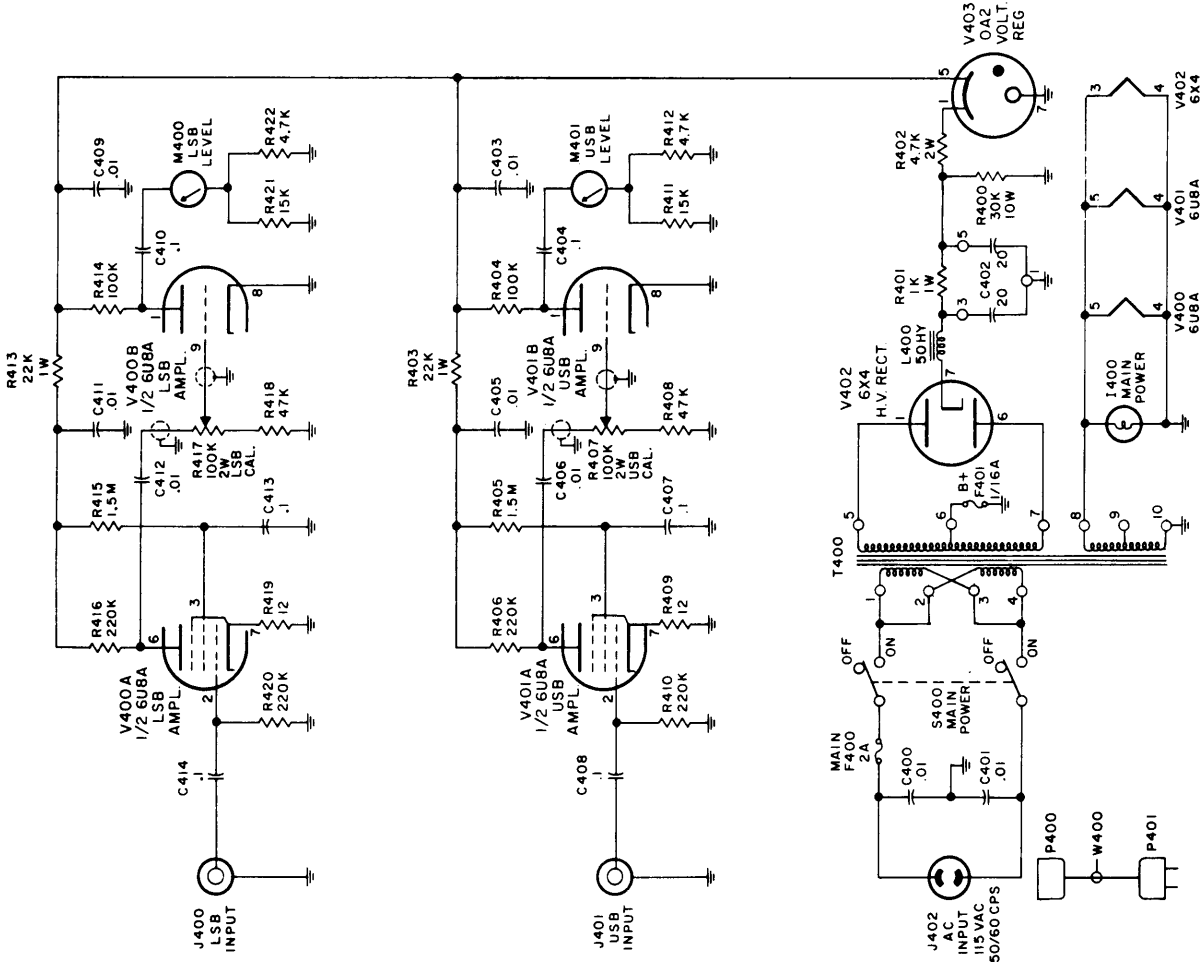

NOTE:  
FOR 220VAC OPERATION  
CHANGE F400 TO 1A

NOTES:  
1. ALL CAPACITORS ARE IN MFDS.  
2. ALL RESISTORS ARE 1/2 WATT,  
UNLESS OTHERWISE SPECIFIED.

LAST SYMBOLS-

- C414
- F401
- I400
- J402
- L400
- M401
- P401
- R422
- S400
- T400
- V403
- W400

Figure II-7-4-3. Schematic Diagram SLM-1 and SLM-2 (Sheet 1 of 2)

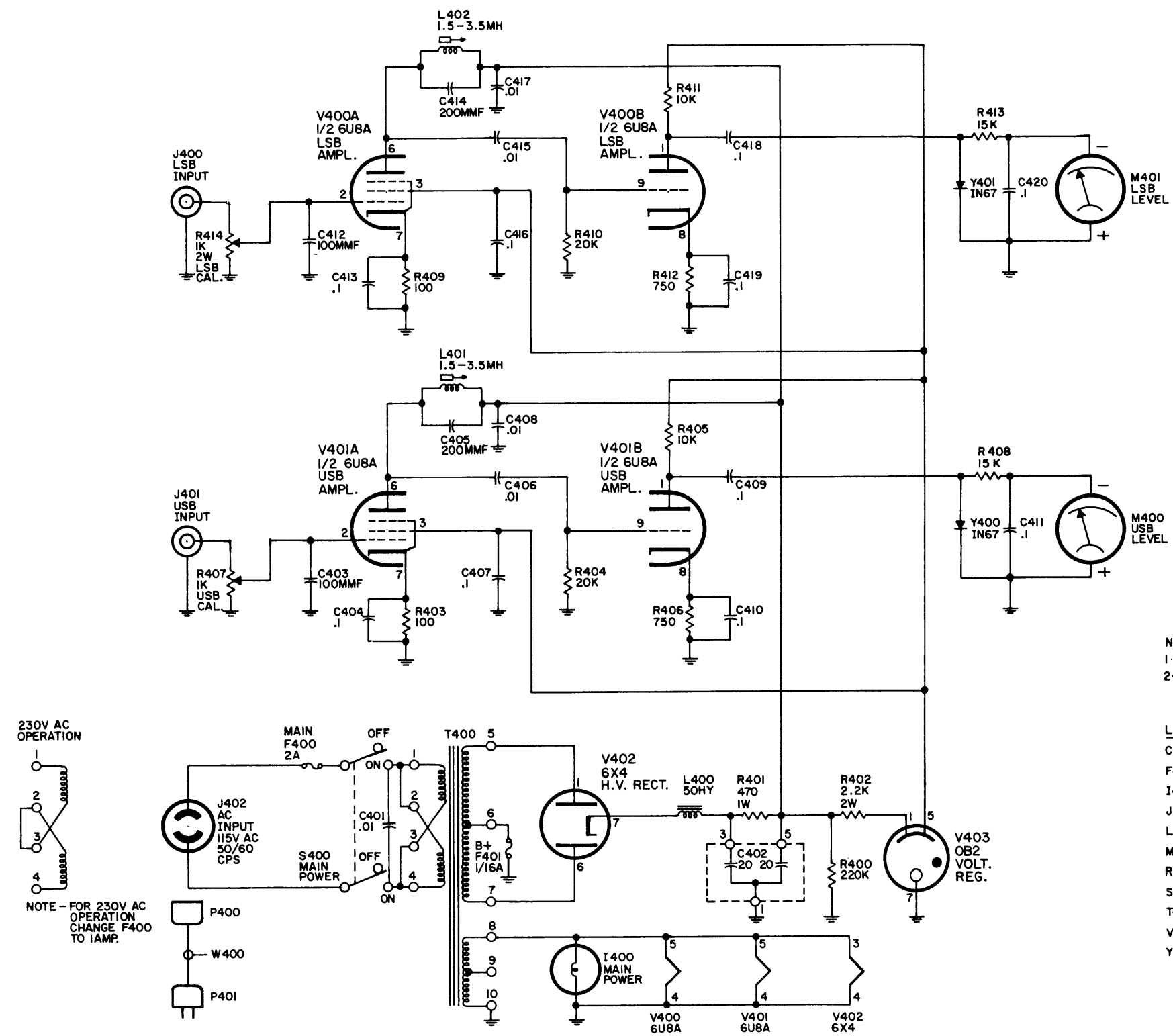

NOTES— UNLESS OTHERWISE SPECIFIED  
 1- ALL CAPACITORS ARE IN MFD.  
 2- ALL RESISTORS ARE 1/2 WATT.

LAST SYMBOLS	MISSING SYMBOLS
C420	C400
F401	
I400	
J402	
L402	
M401	
R414	
S400	
T400	
V403	
Y401	

230V AC OPERATION

NOTE— FOR 230V AC OPERATION CHANGE F400 TO 1AMP.

Figure II-7-4-3. Schematic Diagram, SLM-1 and SLM-2 (Sheet 2 of 2)





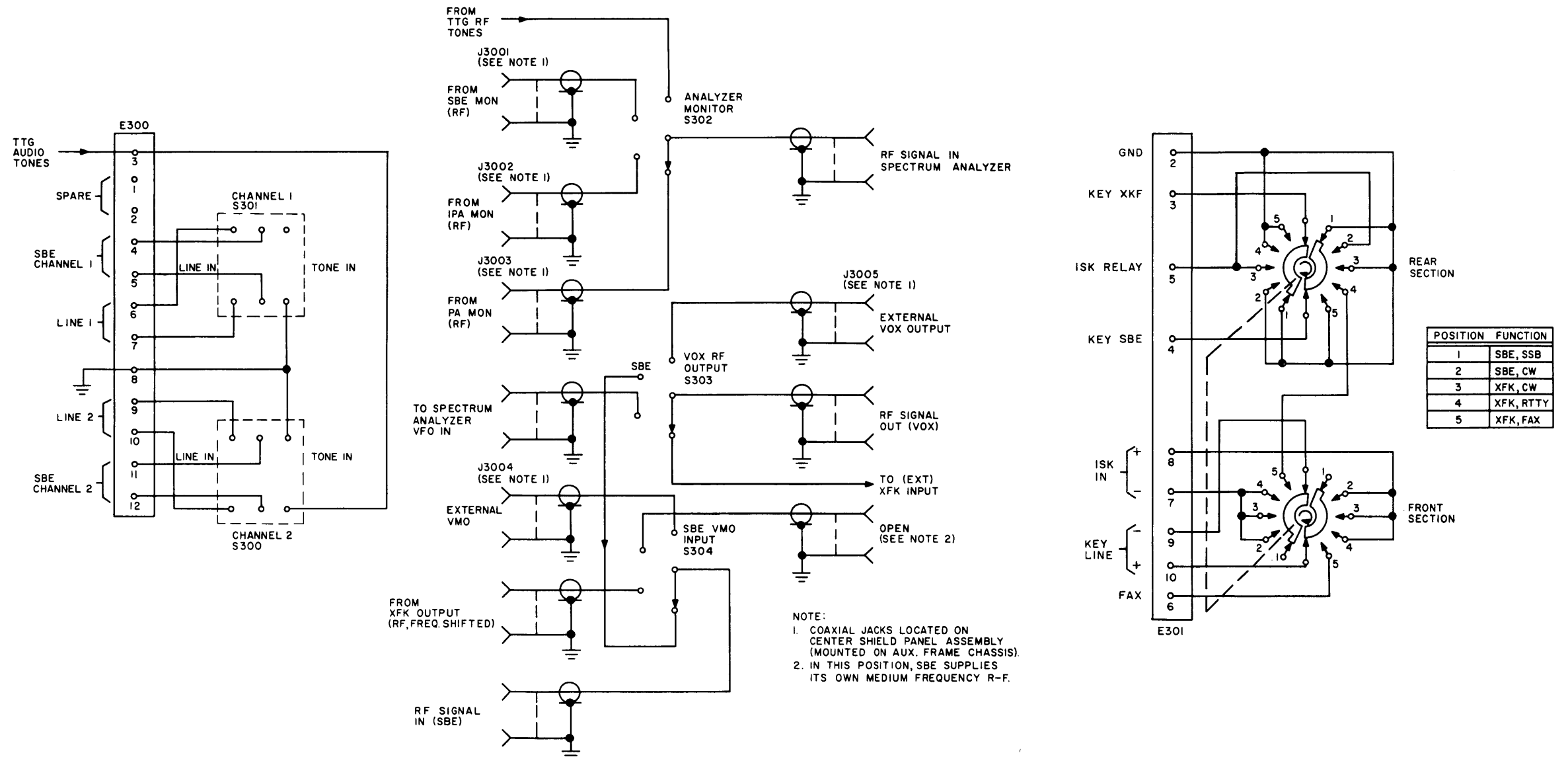

Figure II-7-4-4. Schematic Diagram, MCP (Sheet 2 of 2)

S4001	
POS.	KEYING MODE
1	50V
2	100V
3	60MA
4	20MA

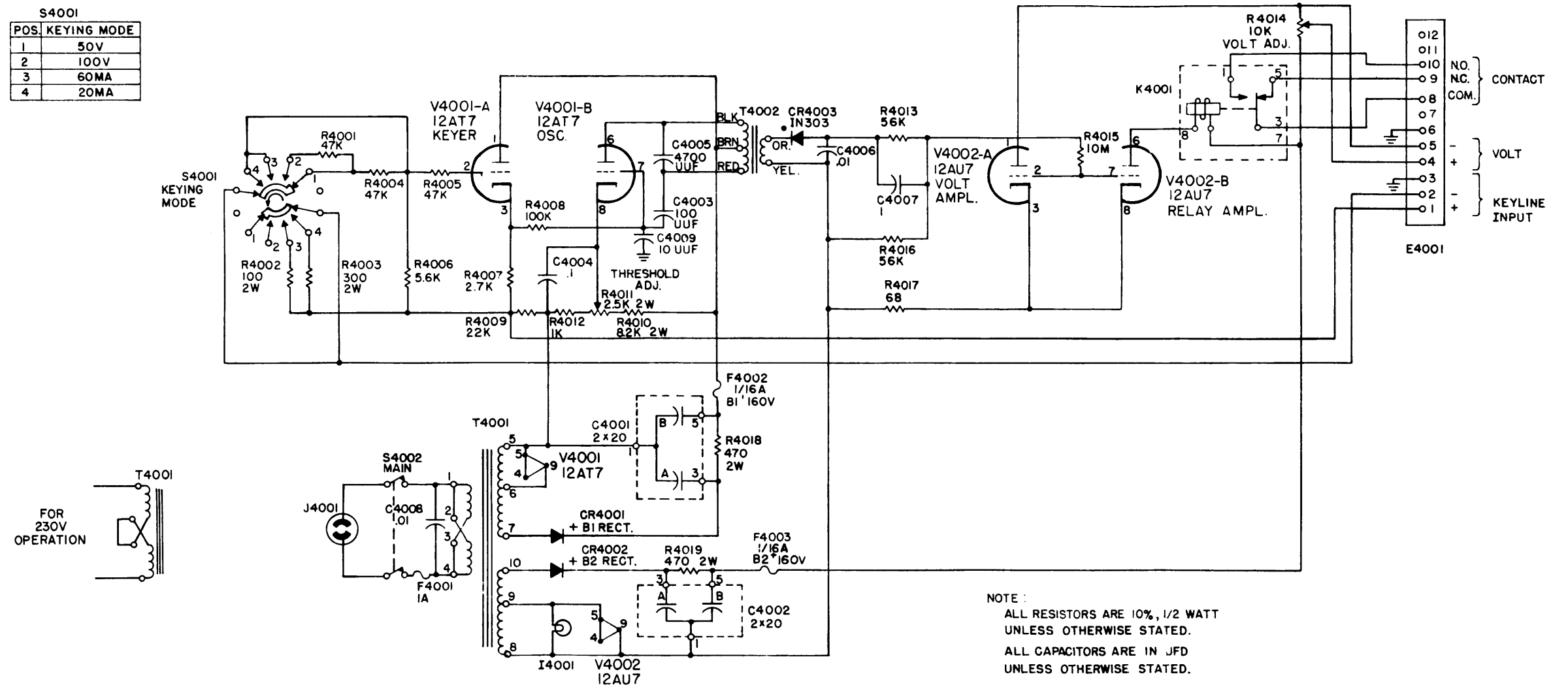

Figure II-7-4-5. Schematic Diagram, ISK

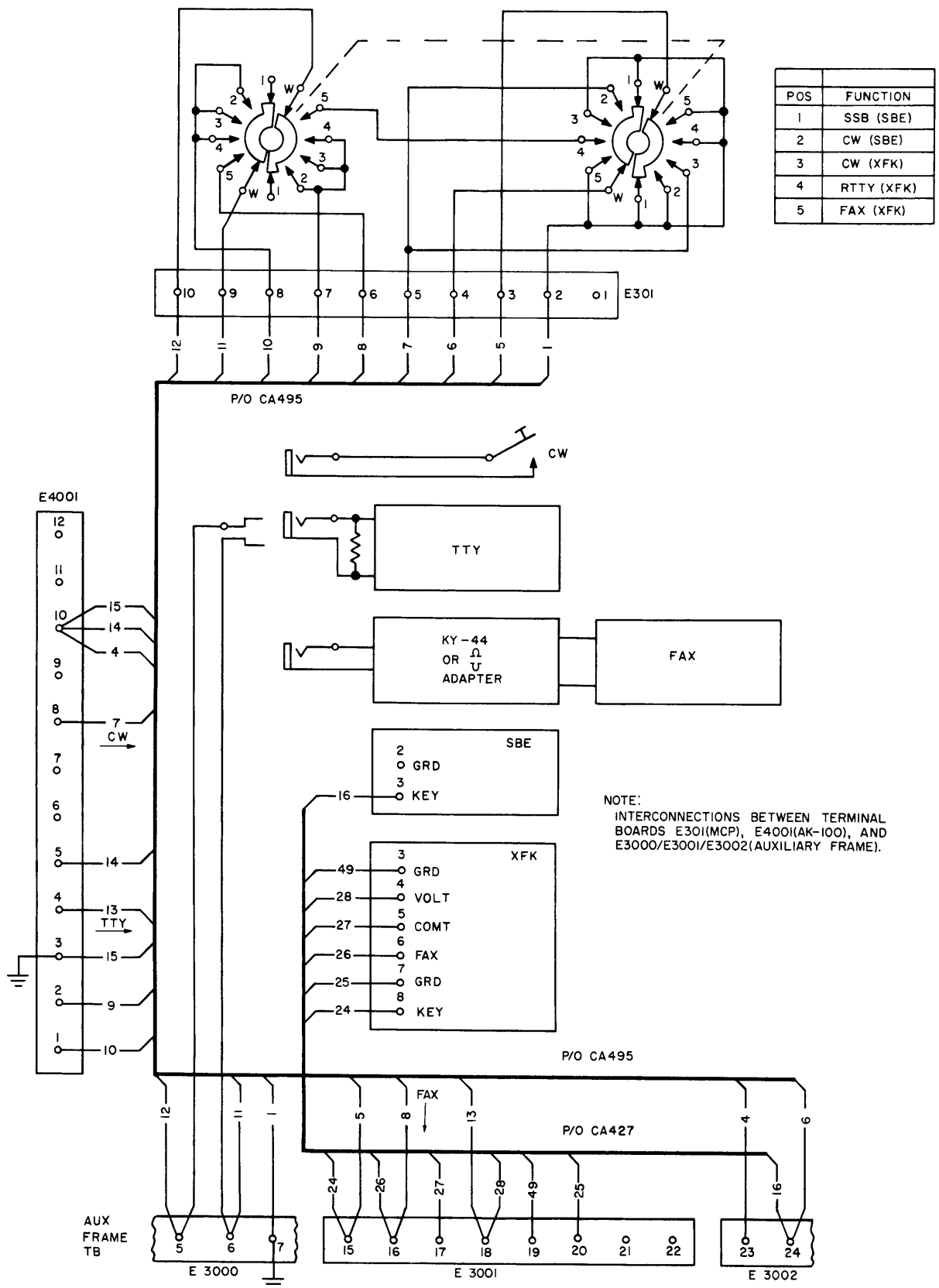

Figure II-7-4-6. Partial Wiring Diagram, Auxiliary Frame Chassis for Non-Synthesized GPT-10K

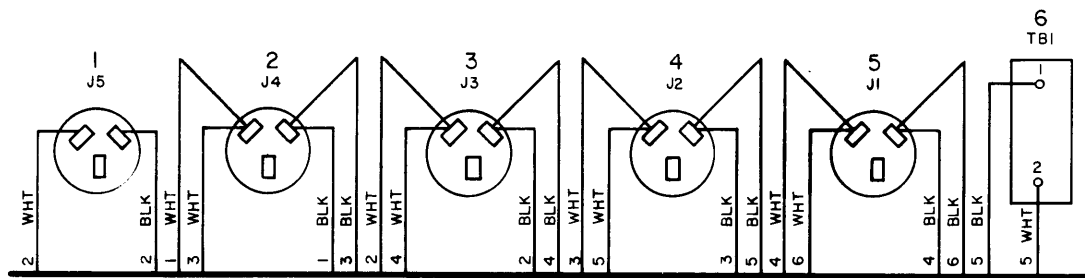
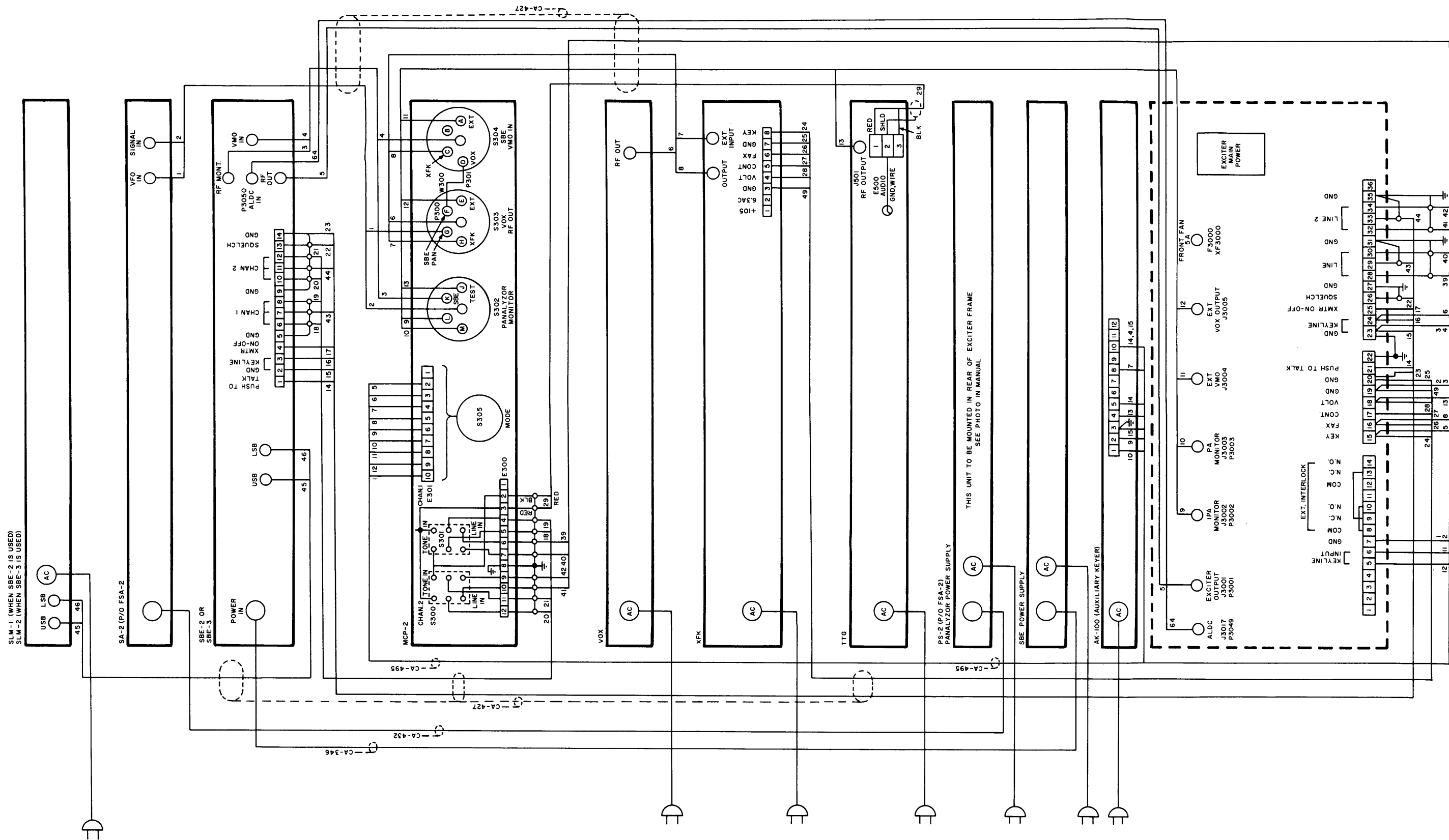

Figure II-7-4-7. Wiring Diagram, APP-1





## SECTION 5 TROUBLE-SHOOTING

### 5-1. GENERAL CONSIDERATIONS.

Refer to companion manual, Volume I, Section 5, paragraphs 5-1 and 5-2.

### 5-2. UNITS IN REMOVABLE DRAWERS IN AX-180.

These units comprise the FSA, SBE, VOX, XFK, and TTG; their trouble-shooting procedures are described respectively in Parts II through VI (Volume II) of this manual.

### 5-3. NON-REMOVABLE UNITS IN AX-180.

These units comprise the Meter Panel (AX-107), the Sideband Level Monitor Unit SLM-1 or -2, Monitor Control Panel MCP-1 or -2, Isolation Keyer AK-100, and the Auxiliary Power Panel APP-1.

Due to the simplicity of AX-107 and APP-1, no trouble-shooting procedures need be given. Continuity tests

should suffice to assure proper circuitry. Since the MCP-1 or -2 contains only toggle and selector switches, trouble-shooting procedures reduce to circuit continuity tests under various switch positions.

a. SIDEBAND LEVEL MONITOR UNIT SLM-1. - See Table II-7-5-1, Voltage and Resistance Chart, SLM-1.

b. SIDEBAND LEVEL MONITOR UNIT SLM-2.- See Table II-7-5-2, Voltage and Resistance Chart, SLM-2.

c. ISOLATION KEYER AK-100. - See Table II-7-5-3, Voltage and Resistance Chart, AK-100.

d. AUXILIARY FRAME CHASSIS AX-180. - The AX-180 is composed largely of a Sola transformer, line filters, circuit breaker, contactors, 115-volt outlets, fan and associated 5-ampere fuse. A volt-ohm-meter is convenient for trouble-shooting the AX-180.

**TABLE II-7-5-1. VOLTAGE AND RESISTANCE  
CHART, SIDEBAND LEVEL MONITOR SLM-1**

RESISTANCE TO CHASSIS

Pin	V400	V401	V402	V403
1	135K	135K	420	35K
2	220K	220K	--	--
3	1.5 Meg	1.5 Meg	0	--
4	0	0	0+	--
5	0+	0+	--	35K
6	280K	280K	420	--
7	12	12	31K	0
8	0	0	--	--
9	47K-150K	47K-150K	--	--

VOLTAGE (DC) TO CHASSIS

Pin	V400	V401	V402	V403
1	+24V*	+34V*	280 a-c	+150
2	-0.8	-0.8	--	--
3	13V	14V	--	--
4	--	--	6.3 a-c	--
5	6.6 a-c	6.6 a-c	--	+150
6	+65V	+60V	280 a-c	--
7	0	0	+250V	0
8	0	0	--	--

\* Varies with choice of tubes to obtain signal balance.

**TABLE II-7-5-2. VOLTAGE AND RESISTANCE  
CHART, SIDEBAND LEVEL MONITOR SLM-2**

RESISTANCE TO CHASSIS

Pin	V400	V401	V402	V403
1	210K	210K	420Ω	200K
2	*525Ω	*450Ω	--	0Ω
3	200K	200K	0Ω	
4	0Ω	0Ω	.1Ω	0Ω
5	.1Ω	.1Ω	--	200K
6	200K	200K	420Ω	--
7	100Ω	100Ω	200K	0Ω
8	750Ω	750Ω	--	--
9	20K	20K	--	--

\* Depends on setting of 1K poteneiometer.

VOLTAGE (DC) TO CHASSIS

Pin	V400	V401	V402	V403
1	+75	+80	280AC	+105
2	0	0	--	--
3	+105	+105	--	--
4	--	--	6.5AC	--
5	6.5AC	6.5AC	--	+105
6	+160	+160	280AC	--
7	+.95	+1.15	+205	--
8	+2.25	+2.10	--	--
9	0	0	--	--

All readings taken with Simpson #260 VOM; AC input, 118V AC; no signal, calibrated unit.

**TABLE II-7-5-3. VOLTAGE AND RESISTANCE  
CHART, ISOLATION KEYS AK-100**

RESISTANCE TO COMMON NEGATIVE

C-4001-1 To Pin	V-4001
1	11K
2	75K
3	24K
4	.2 Ω
5	.2 Ω
6	11K
7	125K
8	2.2K
9	0 Ω

S4001	E4001-1 to V4001-3
1	2.7K
2	2.7K
3	2.7K
4	2.7K

S4001	E4001-2 to V4001-2
1	94K
2	141K
3	47K
4	47K

C-4002-1 To Pin	V-4002
1	10K*
2	10 Meg
3	68 Ω
4	.2 Ω
5	.2 Ω
6	4.5K*
7	10 Meg
8	68 Ω
9	0 Ω

S4001	E4001-1 to E4001-2
1	50K
2	92K
3	100 Ω
4	300 Ω

\* from C-4002-5

VOLTAGE (DC)

V-4001-3 and V4001-1	+130
V-4001-8 and V4001-6	+124
V-4002-3 and V4002-1	+180
V-4002-8 and V4002-6	+180

## SECTION 6 MAINTENANCE

### 6-1. GENERAL CONSIDERATIONS.

Refer to companion manual, Volume I, Section 6, paragraphs 6-1, 6-2, 6-3, and 6-4 where appropriate.

### 6-2. UNITS IN REMOVABLE DRAWERS IN AX-180.

These units comprise the FSA, SBE, VOX, XFK, and TTG; their maintenance procedures are described respectively in Parts V through VI (Volume II) of this manual.

### 6-3. NON-REMOVABLE UNITS IN AX-180.

These units comprise the Meter Panel (AX-107), the Sideband Level Monitor Unit SLM-1 or -2, Monitor Control Panel MCP-1 or -2, Isolation Keyer AK-100, and the Auxiliary Power Panel APP-1. Due to the simplicity of these units, maintenance procedures resolve themselves as follows:

SLM-1 - Corrective Maintenance

SLM-2 - Corrective Maintenance

AK-100 - Corrective Maintenance

Auxiliary Frame Chassis - Preventive, Operators, and Corrective Maintenance.

### 6-4. CORRECTIVE MAINTENANCE FOR SLM-1.

a. **PRELIMINARY TEST.** - Connect unit to power line and energize the set. Observe that all filaments and pilot lamp are illuminated; also that the VR tube is conducting.

b. **LOWER SIDEBAND METER AMPLIFIER.** - Connect a H. P. Model 200-CD Audio Generator and AC VTVM to J400 (LSB input) through a 22,000-ohm resistor. Connect 100-ohm resistor from J400 to ground. With generator set to 1.000 Kc, adjust output of generator until .004 VAC appears at J400. Set R417 (LSB cal control) to maximum. LSB VU meter should read approximately +2.5 db. Turn R417 to minimum. VU meter should read -12 db.

c. **UPPER SIDEBAND METER AMPLIFIER.** - Connect audio generator and AC VTVM to J401 through a 22,000-ohm resistor. Connect 100-ohm resistor from J401 to ground. Set generator to 1.000 Kc and adjust output for .004 VAC at J401. Set R407 (USB cal control) to maximum. USB VU meter should read approx-

imately +2.5 db. Turn R407 to minimum. VU meter should read -12 db.

d. **LOWER AND UPPER SIDEBAND METER AMPLIFIERS.** - Using a coaxial "TEE", join both inputs together and vary generator output level while watching both level indicators. No severe non-linearity should be accepted. Any variation greater than 1/4 db should be tolerated. The cause will generally be found to be large internal difference in one of the meters or vacuum tubes.

### 6-5. CORRECTIVE MAINTENANCE FOR SLM-2.

a. **Set-up Procedure:**

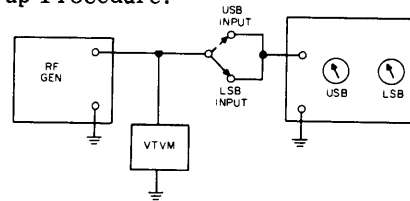

b. Set R. F. output generator at 250 Kc.

c. Hook R. F. output generator output into USB input jack.

d. Place VTVM across USB input terminals. (Daven voltmeter or Equivalent - High input impedance)

e. Set output to .01 volts maximum.

f. Adjust R407 to half resistance (approximately) so that the USB meter will indicate. Then tune L401 for maximum indication on the USB meter.

g. Turn R407 to maximum resistance. Needle on meter should peg the scale. Turn R407 to minimum resistances. Needle should read 0.

h. Adjust R407 to ODB indication on USB meter.

i. For LSB calibration, the R. F. output generator is placed into LSB input jack. R414 is now adjusted. L402 is now tuned. Repeat steps 1 to 8.

### 6-6. CORRECTIVE MAINTENANCE FOR AK-100.

a. **PRELIMINARY TEST - RESISTANCE AND CONTINUITY TEST.**

(1) Wiring of E4001

FROM TERM.	TO TERM.	RESISTANCE MUST BE BETWEEN THE VALUES SPECIFIED IN OHMS	REMARKS
1	2	45K - - 60K	Mode sw in position "50V"
1	2	85K - - 115Ω	Mode sw in position "100V"
1	2	85Ω - - 115K	Mode sw in position "60ma"
1	2	250Ω - - 350Ω	Mode sw in position "20ma"
4	5	Approx 0 - - 12K	Variable by R4014 clockwise for max. R
4	Ground	Open	
1	Ground	Open	
8	Ground	Open	
8	9	Short	The unit must be in its operating (upright) pos.
3	Ground	Short	
6	Ground	Short	

(2) B1 + B2 + Wiring

**NOTE**

Because of selenium rectifiers, it may be necessary to reverse the ohmmeter leads to read proper resistance.

(a) B1 + : Between terminals 1 and 3 at C4001, 9K - 13K

(b) B2 + : Between terminals 1 and 3 at C4002, open

b. INSTRUMENT LAYOUT.

**NOTE**

The square-wave generator must not touch chassis of the AK-100 or any other ground.

(1) Using a clip-lead, ground terminal #1 of C4001.

(2) Using a clip-lead, ground terminal #1 of C4002.

c. INITIAL VOLTAGE CHECK.

(1) Set up the unit as shown in the instrument layout.

(2) Turn the voltage adjust and threshold adjust controls to fully counterclockwise position.

(3) Measure and correlate all voltages as shown in the charts below to be within  $\pm 10$  percent.

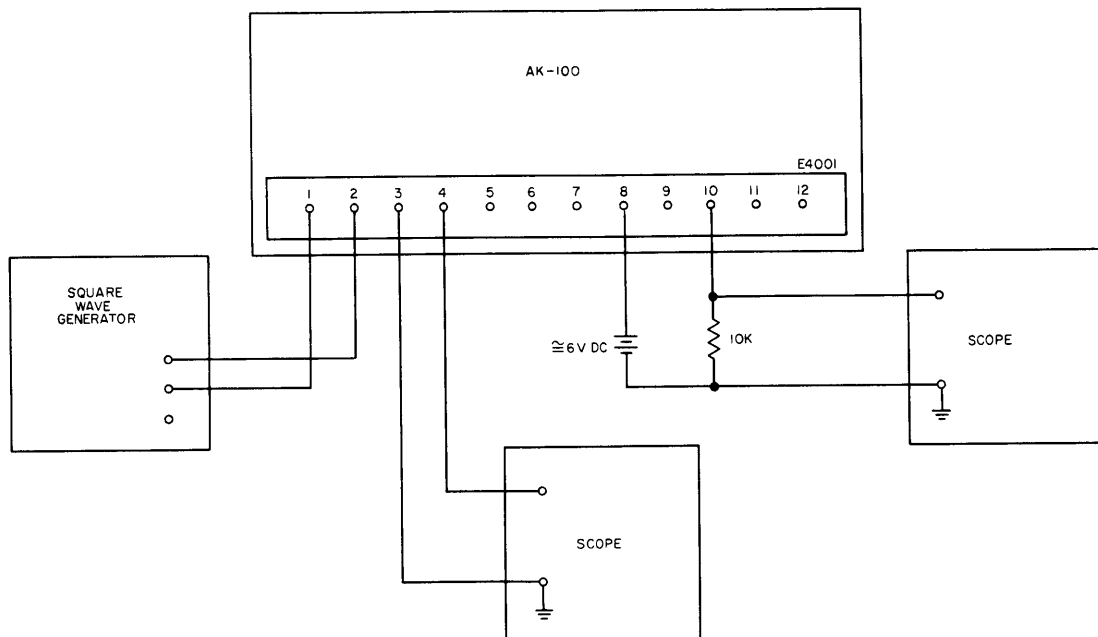

NORMAL READINGS

	Pin 1	Pin 2	Pin 3	Pin 4	Pin 5	Pin 6	Pin 7	Pin 8
V4001A	150 #1.1	22 #.4	24 #0					
V4002A	180 #0	-17 #.12	0 #0					
V4001B						150 #38	3.3 #3.3	19 #.5
V4002B						180 #0	-17 #.1	0 #0
C4001	0		155		155			
C4002	0		180		180			

# A.C. Voltages.  
All voltages measured to ground.

NORMAL READINGS

	1	2	3	4	5	6	7	8	9	10	11	12
K4001	0		0		0		180	180				
E4001	22	22	0	180	180	0	0	0	0	0	0	0

(4) Measure voltage at junction of C4007 and R4016 with respect to ground. The voltage must be between -15 and -20 volts.

(b). Terminal #8 and 10

d. WAVEFORM TEST.

(1) Set the mode switch for "50V" Keying.

(2) Set the square-wave generator for 50V Keying at 50 cps.

(3) Set the voltage adjust control fully counter-clockwise. Adjust the threshold control (approximately in the middle of the potentiometer) until waveforms appears as shown below.

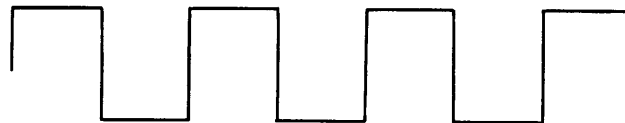

NOTE

The spacing between positive and negative:

(a). Terminal #4



6-7. AUXILIARY FRAME CHASSIS.

a. FRONT AND REAR FAN MOTORS. - These units are hermetically sealed. The fans use induction motors. No maintenance is required.

b. MAIN POWER AUXILIARY FRAME CIRCUIT BREAKER. - When Main Circuit Breaker CB3000, is malfunctioning, replace it as a unit. No general maintenance is required.

c. RELAY CONTACTORS K3000 AND K3001. - Replace contacts or polish contacts with crocus cloth when badly pitted.



## **SECTION 7 PARTS LIST**

Reference designations have been assigned to identify all maintenance parts of the equipment. They are used for marking the equipment (adjacent to the part they identify) and are included on drawings, diagrams, and the parts list. The letters of a reference designation indicate the kind of part (generic group), such as resistor, amplifier, electron tubes, etc. The number differentiates between parts of the same generic group. Parts of the same first major unit are numbered from 1 to 199; parts of the second 201 to 299, etc. Two consecutive series of numbers have been assigned to major units in which there are more than 100 parts of the same generic group. Sockets associated with a particular plug-in device, such as

an electron tube or fuse, are identified by a reference designation which includes the reference designation of the plug-in device. For example, the socket for fuse F7 is designated XF7. The parts for each major unit are grouped together. Column 1 lists the reference series of each major unit, followed by the reference designations of the various parts in alphabetical and numerical order. Column 2 gives the name and describes the various parts. Major part assemblies are listed in their entirety; subparts of a major assembly are listed in alphabetical and numerical order with reference to its major assembly. Column 3 indicates how the part is used within a major component. Column 4 lists each Technical Materiel Corporation part number.

**AUXILIARY FRAME AX-180**

SYM	DESCRIPTION	FUNCTION	TMC PART NO.
B3000	FAN, axial (CCW): single phase; 115/230 v, 50/60 cps, capacitance 4 uf; nominal RPM 3400; insulation class B; 100 watts full load.	Air Circulator	BL-105
B3001	Same as B3000.	Air Circulator	
C3000	DELETED		
C3001	DELETED		
C3002	DELETED		
C3003	DELETED		
C3004	DELETED		
C3005	DELETED		
C3006	DELETED		
C3007	DELETED		
C3008	DELETED		
C3009	DELETED		
C3010	CAPACITOR, feed-thru: ceramic; 1000 uuf, +20%, 500 wvdc.	Feed-thru Bypass PA Screen Volt	CK70A102M
C3011	Same as C3010.	Feed-thru Bypass PA Screen Volt	
C3012	Same as C3010.	Feed-thru Bypass PA Plate Volt	
C3013	Same as C3010.	Feed-thru Bypass PA Bias	
C3014	Same as C3010.	Feed-thru Bypass PA Bias	
C3015	Same as C3010.	Feed-thru Bypass Alarm	
C3016	Same as C3010.	Feed-thru Bypass Alarm	
C3017	CAPACITOR, fixed: paper; 4 uf, +10%, 600 wvdc.	Starter, B3001	CP41B1FF405K
C3018	Same as C3017.	Starter, B3000	
C3019	CAPACITOR, fixed: mica; 1000 uuf, +10%, 500 wvdc.	Bypass For Key	CM20B102K
C3020	Same as C3019.	Feed-thru Bypass Fax Line	
C3021	Same as C3019.	Bypass For Contact Keying Line	
C3022	Same as C3019.	Bypass For Volt. Keying Line	
C3023	DELETED		

**AUXILIARY FRAME AX-180**

SYM	DESCRIPTION	FUNCTION	TMC PART NO.
C3024	DELETED		
C3025	Same as C3019.	Bypass For Push To Talk	
C3026	DELETED		
C3027	Same as C3019.	Bypass for Grd/Key Line	
C3028	Same as C3019.	Bypass For Xmtr On/Off Line	
C3029	Same as C3019.	Bypass For Squelch Line	
C3030	Same as C3019.	Bypass for SB in Line	
C3031	Same as C3019.	Bypass for SB in Line	
C3032	Same as C3019.	Bypass for SB in Line 1	
C3033	Same as C3019.	Bypass for SB in Line 2	
C3034	Same as C3019.	Bypass for SB in Line 2	
C3035	Same as C3019.	Bypass for SB in Line 2	
C3036	Same as C3019.	Bypass for Key-Line Input	
C3037	Same as C3019.	Bypass for Key-Line Input	
CB3000	BREAKER, circuit: 110/230 VAC, 10 amps, double pole.	Main Power Breaker	SW-251
DS3000	BUZZER, 230 VAC; 5-1/2" mtg. centers.	HV Plate Off Alarm	BZ-100
E3000	TERMINAL STRIP, barrier type: plastic; 14 terminals, screw w/feed thru solder lug type.	Ext. Interlock Term. Bd.	TM-100-14
E3001	TERMINAL STRIP, barrier type: plastic; 8 terminals, screw w/feed thru solder lug type.	Ext. Control Lines T. B.	TM-100-8
E3002	Same as E3000.		
E3003	TERMINAL STRIP, barrier type, 2 terminals, black bakelite.	I3000 Term. Bd.	TM-102-2
E3004	CONTACT SET, relay: for K3000, TMC Part Number RL-130; consisting of 3 each moveable contacts, 3 each line contacts, 3 each load contacts.	Contact	AX-176
E3005	Same as E3004.	Contact	
E3006	Same as E3004.	Contact	
E3007	Same as E3004.	Contact	
E3008	Same as E3004.	Contact	

**AUXILIARY FRAME AX-180**

SYM	DESCRIPTION	FUNCTION	TMC PART NO.
E3009	Same as E3004.	Contact	
E3010	TERMINAL, FEED-THRU: insulated; brass, silver plated terminal, 1/4 in. dia mtg hole.	Feed-thru	TE-114-2
E3011	Same as E3010.	Feed-thru	
E3012	Same as E3010.	Feed-thru	
E3013	Same as E3010.	Feed-thru	
E3014	Same as E3010.	Feed-thru	
E3015	Same as E3010.	Feed-thru	
E3016	Same as E3010.	Feed-thru	
E3017	Same as E3010.	Feed-thru	
E3018	Same as E3010.	Feed-thru	
E3019	Same as E3010.	Feed-thru	
E3000	FUSE, cartridge: 5 amp; time lag.	B3000 Fuse	FU-102-5
I3000	LAMP, incandescent: clear; 230/250 volts, 40 watts; standard screw base; 4" x 1-7/8" o/a.	Warning HV ON	BI-106-1
I3001	LAMP, fluorescent: standard, cool white; 1/2 in. dia x 11-1/4 in. lg.	Meter Illum.	BI-107
J3000	CONNECTOR, receptacle: female, 4 contacts. J3000 used on Cable, W3000.	B3001 Input Jack	MS3102A-14S-2S
J3001	JACK, bulkhead. J3001 used on Cable, W3001.	SBE Output Jack	JJ-172
J3002	Same as J3001. J3002 used on Cable, W3001.	IPA Monitor Jack	
J3003	Same as J3001. J3003 used on Cable, W3001.	PA Monitor Jack	
J3004	Same as J3001. J3004 used on Cable, W3001.	Ext. VMO Jack	
J3005	Same as J3001. J3005 used on Cable, W3005.	Ext. VOX Output Jack	
J3006	Same as J3000.	B3000 Input Jack	
J3007	RECEPTACLE, twistlock: female; brown bakelite.	110 VAC Outlet	JJ-170
J3008	Same as J3007.	110 VAC Outlet	
J3009	Same as J3007.	110 VAC Outlet	

**AUXILIARY FRAME AX-180**

SYM	DESCRIPTION	FUNCTION	TMC PART NO.
J3010	Same as J3007.	110 VAC Outlet	
J3011	Same as J3007.	110 VAC Outlet	
J3012	Same as J3007.	110 VAC Outlet	
J3013	Same as J3007.	110 VAC Outlet	
J3014	Same as J3007.	110 VAC Outlet	
J3015	DELETED		
J3016	NOT USED		
J3017	Same as J3001. J3017 used on Cable, W3001.		
K3000	CONTACTOR, relay: 220 v, 60 cps coil; auxiliary switch mounted on right side of panel; normally closed contacts.	Primary Contactor HV Rectifier	RL-130-1
K3001	CONTACTOR, relay: 220 v, 60 cps coil; auxiliary switch mounted on left side of panel; normally open contacts.	Primary Contactor HV Rectifier	RL-130-2
M3000	METER, PA Screen: 0-1500 volt scale; 1 milliamp dc scale; 4-1/2 in. square case.	PA Screen Volt. Meter	MR-119
M3001	METER, PA bias: 0-400 neg. volt. scale; 1 milliamp dc movement; 4-1/2 in. square case.	PA Bias Volt. Meter	MR-122
M3002	METER, PA plate: 0-10 kilovolt scale; 1 milliamp dc movement; 4-1/2 in. square case.	PA Plate Volt. Meter	MR-121
M3003	TIME DELAY: 20 seconds; quick make, quick break, 250 v, 5 amp switches.	Time Delay Relay HV Rectifier	TI-100
MP3000	FILTER, air: single pad; 16" lg x 16" wd x 1/2" thk.	Air Filter	AD-103-4
MP3001	FILTER, air: single pad; 11-3/8" lg x 10-1/8" wd x 1/2" thk.	Air Filter	AD-103-2
MP3002	Same as MP3001.	Air Filter	
P3000	CONNECTOR, plug: male; AN pin type. P3000 used on Cable, W3000.	Input	MS3106B-20-27P
P3001	CONNECTOR, coaxial. P3001 used on Cable, W3000.	SBE Output	PL-169
P3002	Same as P3001. P3002 used on Cable, W3000.	IPA Monitor	
P3003	Same as P3001. P3003 used on Cable, W3000.	PA Monitor	

**AUXILIARY FRAME AX-180**

SYM	DESCRIPTION	FUNCTION	TMC PART NO.
P3004	CONNECTOR, receptacle: male.	B3001 Input Plug	MS3106A-14S-2P
P3005	Same as P3001. P3005 used on Cable, W3000.	SBE Output	
P3006	Same as P3001. P3006 used on Cable, W3000.	IPA Monitor	
P3007	Same as P3001. P3007 used on Cable, W3000.	PA Monitor	
P3008	Same as P3004.	B3000 Input Plug	
P3009	Same as P3001. P3009 used on Cable, W3001.	Cable Connectors	
P3010	Same as P3001. P3010 used on Cable, W3001.	Cable Connectors	
P3011	Same as P3001. P3011 used on Cable, W3001.	Cable Connectors	
P3012	Same as P3001. P3012 used on Cable, W3001.	Cable Connectors	
P3013	Same as P3001. P3013 used on Cable, W3001.	Cable Connectors	
P3014	Same as P3001. P3014 used on Cable, W3001.	Cable Connectors	
P3015	Same as P3001. P3015 used on Cable, W3001.	Cable Connectors	
P3016	Same as P3001. P3016 used on Cable, W3001.	Cable Connectors	
P3017	Same as P3001. P3017 used on Cable, W3001.	Cable Connectors	
P3018	Same as P3001. P3018 used on Cable, W3001.	Cable Connectors	
P3019	Same as P3001. P3019 used on Cable, W3001.	Cable Connectors	
P3020	Same as P3001. P3020 used on Cable, W3001.	Cable Connectors	
P3021	Same as P3001. P3021 used on Cable, W3001.	Cable Connectors	
P3022	Same as P3001. P3022 used on Cable, W3001.	Cable Connectors	
P3023	Same as P3001. P3023 used on Cable, W3001.	Cable Connectors	



**AUXILIARY FRAME AX-180**

SYM	DESCRIPTION	FUNCTION	TMC PART NO.
P3024	Same as P3001. P3024 used on Cable, W3001.	Cable Connectors	
P3025	Same as P3001. P3025 used on Cable, W3001.	Cable Connectors	
P3026	Same as P3001. P3026 used on Cable, W3001.	Cable Connectors	
P3027	Same as P3001. P3027 used on Cable, W3001.	Cable Connectors	
P3028	Same as P3001. P3028 used on Cable, W3001.	Cable Connectors	
P3029	Same as P3001. P3029 used on Cable, W3001.	Cable Connectors	
P3030	Same as P3001. P3030 used on Cable, W3001.	Cable Connectors	
P3031	Same as P3001. P3031 used on Cable, W3001.	Cable Connectors	
P3032	Same as P3001. P3032 used on Cable, W3001.	Cable Connectors	
P3033	Same as P3001. P3033 used on Cable, W3001.	Cable Connectors	
P3034 thru P3047	NOT USED		
P3048	Same as P3001. P3048 used on Cable, W3000.	ALDC	
P3049	Same as P3001. P3049 used on Cable, W3000.	ALDC	
P3050	Same as P3001. P3050 used on Cable, W3001.	ALDC	
R3000	RESISTOR, fixed: finstrip; 12 ohms, 1250 watts; 15-1/4" lg x 2" wide x 1-3/8" high o/a.	Power Dropping HV Rect.	RR-127-1
R3001	Same as R3000.	Power Dropping HV Rectifier	
R3002	Same as R3000.	Power Dropping HV Rectifier	
R3003	RESISTOR, fixed: wire wound; 600 ohms, 25 watts; mtg brackets mount-on 2-5/8" centers.	I3001 Dropping	RW-102
R3004	RESISTOR, fixed: composition; 470 K ohms, <u>+10%</u> , 2 watts.	Metering	RC42GF474K

**AUXILIARY FRAME AX-180**

SYM	DESCRIPTION	FUNCTION	TMC PART NO.
S3000	STARTER, fluorescent lamp: 8 watts; 3/16" dia x 1-1/2" lg o/a.	Starter, J3001	PO-170
T3000	TRANSFORMER, voltage regulator: primary 190-260 VAC, 50/60 cps; sec. - 118v/1 KVA, voltage regulation <u>+1%</u> over primary range.	Volt. Reg. Aux. Frame	TF-208
T3001	BALLAST, fluorescent lamp: 8 watts, 118 volts; .17 amps, 60 cps; 1-1/8" wide x 7/8" high x 5-15/16" lg o/a; 5-1/2" leads.	Ballast for J3001	PO-169
W3000	CABLE ASSEMBLY, SPECIAL PURPOSE, ELECTRICAL, BRANCHED: consisting of various MIL type RG-174/U and MWC wire; 10 connectors, symbols J3000, P3000, 3001, 3002, 3003, 3005, 3006, 3007, 3048, 3049 and various terminal lugs.	Main Frame to Center Panel Interconnect	CA-430
W3001	CABLE ASSEMBLY, SPECIAL PURPOSE ELECTRICAL, BRANCHED: consisting of various MIL type RG-174/U and MWG wire; 32 connectors, symbols J3001, 3002, 3003, 3004, 3005, 3017, P3009, 3010, 3011, 3012, 3013, 3014, 3015, 3016, 3017, 3018, 3019, 3020, 3021, 3022, 3023, 3024, 3025, 3026, 3027, 3028, 3029, 3030, 3031, 3032, 3033, 3050 and various terminal lugs.	Main Cable	CA-427
XF3000	HOLDER, fuse: 100-250 volt, 20 amp; neon bulb indicator, 220 K ohm resistor.	Holder for F3000	FH-104-3
XI3000	SOCKET, lamp: with red lens.	HV ON Light Socket I3000	AX-124
XI3001A	SOCKET, fluorescent lamp: 75 watts, 250 volts; 1-1/32" high x 5/8" wide x 5/16" thk o/a; 6 in. leads.	Socket for I3001	TS-141
XI3001B	Same as XI3001A.	Socket for I3001	
XS3000	SOCKET, starter: fluorescent; 660 watts, 250 volts; 1-13/16" lg x 1-11/16" wide x 7/16" deep o/a; 8-3/4" leads.	Socket for S3000	TS-140

**SIDEBAND MONITOR MODEL SLM**

SYM	DESCRIPTION	FUNCTION	TMC PART NO.
C400	CAPACITOR, fixed: ceramic disc type; .01 ufd, +80 -20%.	Line Bypass	CC-100-16
C401	Same as C400.	Line Bypass	
C402	CAPACITOR, fixed: electrolytic; 2 sections; 20 mfd, 450 wvdc, each section.	Filter	CE52F200R
C403	Same as C400.	Bypass	
C404	CAPACITOR, fixed: ceramic; .1 mfd, +80 -20%, 500 wvdc.	Blocking	CC-100-28
C405	Same as C400.	Bypass	
C406	Same as C400.	Coupling	
C407	Same as C404.	Screen Bypass	
C408	Same as C404.	Blocking	
C409	Same as C400.	Bypass	
C410	Same as C404.	Blocking	
C411	Same as C400.	Bypass	
C412	Same as C400.	Coupling	
C413	Same as C404.	Screen Bypass	
C414	Same as C404.	Blocking	
F400	FUSE, cartridge: 2 amp.	Fuse, Line	FU-100-2
F401	FUSE, cartridge: 1/16 amp; time lag.	B+ Fuse	FU-102-.062
I400	LAMP, incandescent: 6-8 v; 250 ma; T-3-1/4 clear bulb; bayonet base.	Main Power Indicator	BI-101-44
J400	CONNECTOR, receptacle: electrical; 1 female contact; 52 ohms; BNC type.	LSB Input	UG-625/U
J401	Same as J400.	USB Input	
J402	CONNECTOR, receptacle: male; two contacts, 10 amps at 250 v., 15 amps at 125 v, twist lock type.	AC Line Input	JJ-100
L400	REACTOR, filter: 50 henries; DC resistance approx. 800 ohms; 30 ma DC; insulated for 1500 v; in accordance with MIL-T-27, GR 1 CL. A FAM. 30.	Filter Reactor	TF-166
M400	METER, level indicating: -20 to +3 db; square flush case.	LSB Level Ind.	MR-101-1
M401	Same as M400.	USB Level Ind.	

**SIDEBAND MONITOR MODEL SLM**

SYM	DESCRIPTION	FUNCTION	TMC PART NO.
P400	CONNECTOR, plug, male, twist lock. Part of W400, TMC Part Number CA-435-1.		
P401	CONNECTOR, plug, male, twist lock. Part of W400, TMC Part Number CA-435-1.		
R400	RESISTOR, fixed: wire wound; 30,000 ohms, +5%, 10 watts.	Bleeder	RW-109-39
R401	RESISTOR, fixed: composition; 1,000 ohms, +10%, 1 watt.	Dropping	RC30GF102K
R402	RESISTOR, fixed: composition; 4700 ohms, +10%, 2 watts.	Dropping	RC42GF472K
R403	RESISTOR, fixed: composition; 22,000 ohms, +5%, 1 watt.	Decoupling	RC30GF223J
R404	RESISTOR, fixed: composition; 100,000 ohms, +5%, 1/2 watt.	Plate Load	RC20GF104J
R405	RESISTOR, fixed: composition; 1.5 megohms, +5%, 1/2 watt.	Screen Dropping	RC20GF155J
R406	RESISTOR, fixed: composition; 220,000 ohms, +5%, 1/2 watt.	Plate Load	RC20GF224J
R407	RESISTOR, variable: composition; 100,000 ohms, +10%, 2 watts, linear taper.	USB Cal	RV4ATSA104B
R408	RESISTOR, fixed: composition; 47,000 ohms, +5%, 1/2 watt.	Grid Bias	RC20GF473J
R409	RESISTOR, fixed: composition; 12 ohms, +5%, 1/2 watt.	Cathode Bias	RC20GF120J
R410	Same as R406.	Grid Bias	
R411	RESISTOR, fixed: composition; 15,000 ohms, +5%, 1/2 watt.	Meter Mult.	RC20GF153J
R412	RESISTOR, fixed: composition; 4700 ohms, +5%, 1/2 watt.	Meter Mult.	RC20GF472J
R413	Same as R403.	Decoupling	
R414	Same as R404.	Plate Load	
R415	Same as R405.	Screen Dropping	
R416	Same as R406.	Plate Load	
R417	Same as R407.	LSB Cal	
R418	Same as R408.	Grid Bias	
R419	Same as R409.	Cathode Bias	

**SIDEBAND MONITOR MODEL SLM**

SYM	DESCRIPTION	FUNCTION	TMC PART NO.
R420	Same as R406.	Grid Bias	
R421	Same as R411.	Meter Mult.	
R422	Same as R412.	Meter Mult.	
S400	SWITCH, toggle: DPST; 3 amp, 250 v, phenolic body.	Main Power	ST-22K
T400	TRANSFORMER, power: primary 110/220 v, 50/60 cps, single phase; section 1; 250-0-250 V RMS, 35 ma DC; section 2; 6.3 v, CT, 30.	Power Trans.	TF-126
V400 A&B	TUBE, electron: 6U8A; 9 pin miniature.	LSB Amplifier	6U8A
V401 A&B	Same as V400.	USB Amplifier	
V402	TUBE, electron: full wave rectifier, 7 pin miniature.	HV Rectifier	6X4
V403	TUBE, electron: voltage regulator, 7 pin miniature operating at 150 V DC; 5 amps, min. 30 amps, max. current.	Volt. Regulator	OA2
W400	CABLE ASSEMBLY, power: consists of P400, P401.	AC Power	CA-435-1
XC402	SOCKET, electron tube: octal.	Filter Cap. Socket	TS101P01
XF400	FUSE HOLDER, bayonet base: 100/250 v., neon lamp, clear knob, black plastic body, 13/16" x 2-13/16" o/a.	Main Fuse Holder	FH-104-3
XF401	Same as XF400.	B+ Fuse Holder	
XI400	LIGHT, indicator: w/red frosted lens; for miniature bayonet base, T-3-1/4 bulb.	Main Power Indicator Assy.	TS-106-1
XV400	SOCKET, electron tube: 9 pin miniature.	LSB Amplifier Socket	TS103P01
XV401	Same as XV400.	USB Amplifier Socket	
XV402	SOCKET, electron tube: 7 pin miniature.	HV Rectifier Socket	TS102P01
XV403	Same as XV402.	Volt. Reg. Socket	

**MONITOR CONTROL PANEL MODEL MCP-1**

SYM	DESCRIPTION	FUNCTION	TMC PART NO.
E300	TERMINAL STRIP, barrier type: 12 contacts, 6-32 nickel plated brass screws; phenolic body.	Terminal Strip	TM-102-12
P300	CONNECTOR, plug: coaxial.	Interconnect Plug	PL-169
P301	Same as P300.	Interconnect Plug	
S300	SWITCH, toggle: DPDT, 3 amps, 250 volts, bat type toggle.	SW, Audio Line	ST-22N
S301	Same as S300.	SW, Audio Line	
S302	SWITCH, coaxial: type BNC; 5 connectors, 100 watts, non-shorting contacts.	SW, Panalyzer	SW-239
S303	Same as S302.	SW, VOX RF Out	
S304	Same as S302.	SW, SBE VMO Out	

**AUXILIARY POWER PANEL MODEL APP-1**

SYM	DESCRIPTION	FUNCTION	TMC PART NO.
E1	TERMINAL STRIP, barrier type: 2 terminals; four 6-32 x 1/4 inch screws; bakelite base.		TM-102-2
J1	CONNECTOR, receptacle: electrical; 3 contacts, male; 115/230 VAC.	Utility Outlet	JJ-173
J2	Same as J1.		
J3	Same as J1.		
J4	Same as J1.		
J5	Same as J1.		