

**ADDENDUM**  
**for**  
**MODEL GPR-90(RX)**  
**(R-840/URR)**

The purpose of this addendum is to provide the necessary information required to operate the TMC Model GPR-90(RX).

In general the instruction book as written will apply to the GPR-90(RX) with the following

information to cover the added features of crystal and external oscillator operation.

The following information does not supercede but adds to the existing text of book.

**SECTION I**  
**GENERAL DESCRIPTION**

**1. DESCRIPTION**

The TMC Model GPR-90(RX), in addition to those features inherent in the GPR-90, provides 10 crystal positions for highly stable HFO and a connection for external oscillator. Additional controls are provided as follows:

**A. HFO switch**

(1) In the VAR position the receiver HFO is "ON" permitting variable (normal) operation.

(2) In the EXT position the receiver HFO is "OFF" permitting the use of an external os-

cillator, such as the TMC Models PMO (0-459/URT) or VOX (0-330/FR), as the HFO.

(3) In the XTAL positions, selection of any one of 10 predetermined fixed frequencies is possible.

**B. XTAL ADJ control**

(1) This control permits the "pulling" of the crystal frequency, to adjust for tolerance of the crystals and drift of the transmitter.

The GPR-90(RX) employs 17 tubes and is panel mounted measuring 19 in. wide x 10-1/2 in. high x 14 deep.

**SECTION II**  
**INSTALLATION**

**11. EXTERNAL OPERATION**

A stable external oscillator of 75 ohms output impedance with a minimum of 1 volt output is connected through a cable (consisting of RG-59/U with a UG-260/U connector) to J5, located adjacent to V17 on the amplifier crystal oscillator chassis.

The frequency of the external oscillator is determined as follows:

**A.** Where the signal frequency lies between .54 Mc and 5.6 Mc.

The external oscillator frequency is:

$$F_o = F_s + 0.455 \text{ Mc}$$

Example: For a 1 Mc signal the oscillator frequency would be;

$$F_o = 1.000 + 0.455 \text{ Mc} = 1.455 \text{ Mc}$$

**B.** Where the signal frequency lies between 5.6 Mc and 31.5 Mc.

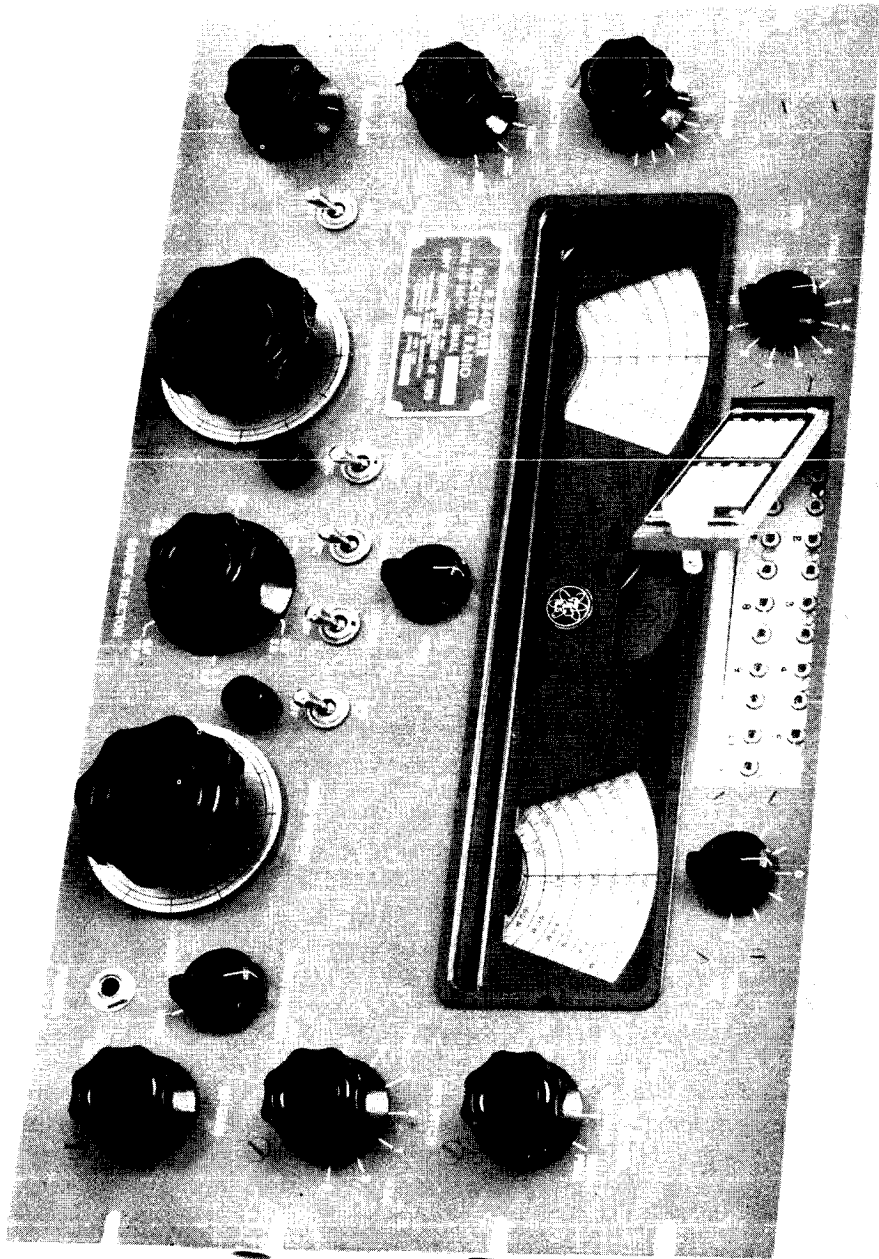

Front View Model GPR-90RX (R-840/URR)

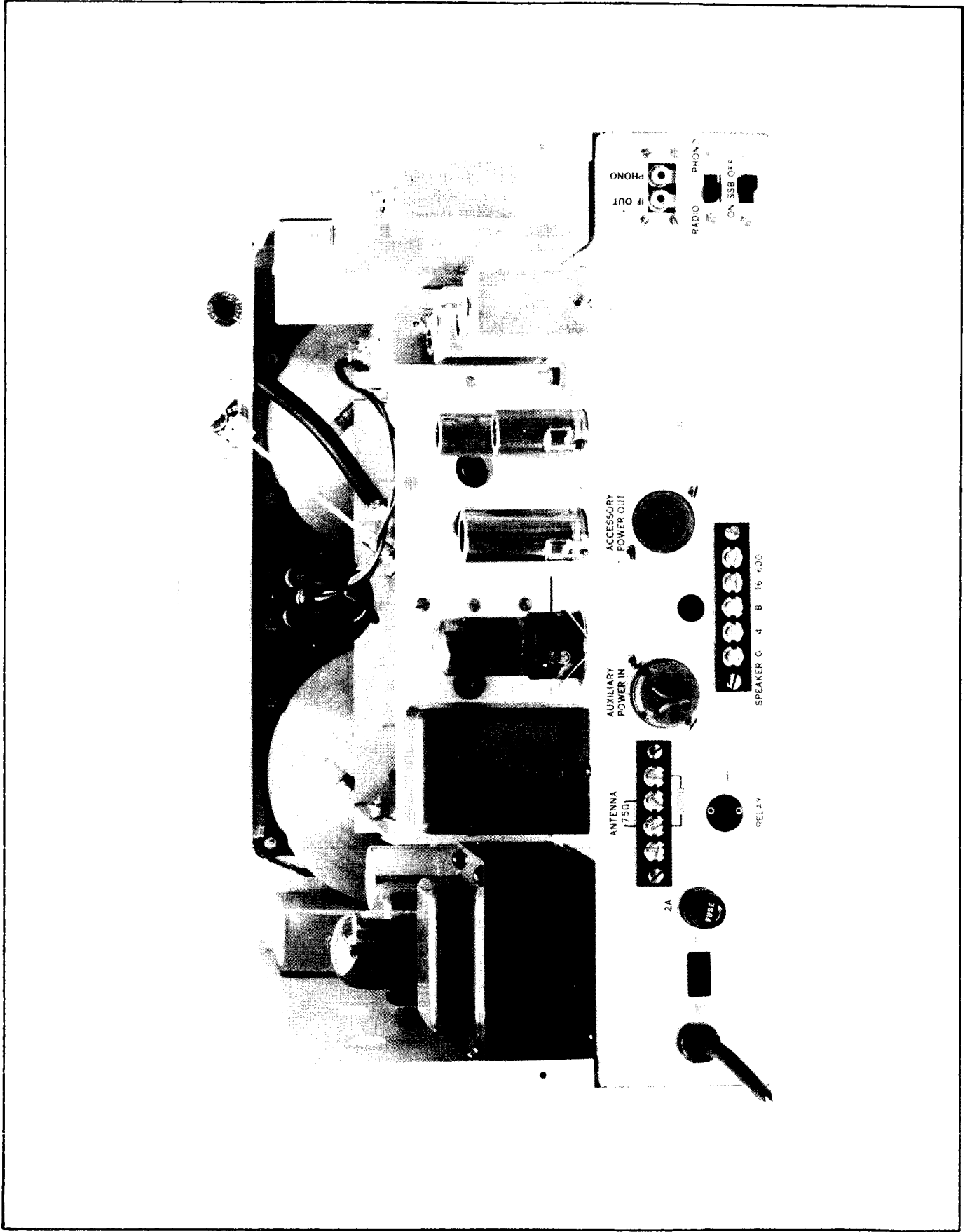

Rear View Model GPR-90RX (R-840/URR)

The external oscillator frequency is:

$$F_o = F_s + 3.955 \text{ Mc}$$

Example: For a 25 Mc signal the oscillator frequency would be;

$$F_o = 25.000 + 3.955 = 28.955$$

where:  $F_o$  = Oscillator frequency

$F_s$  = Signal frequency

#### NOTE

THE EXTERNAL OSCILLATOR SHOULD BE TURNED "OFF" OR DISCONNECTED FROM THE RECEIVER WHEN NOT IN EXTERNAL OPERATION.

## 12. XTAL OPERATION

No special connections are required for this mode of operation.

The frequency of the crystals required for use in this operation are determined as follows:

A. Where the signal frequency lies between .54 Mc and 5.6 Mc.

The crystal frequency is:

$$F_x = F_s + 0.455 \text{ Mc}$$

Example: For a 1 Mc signal the crystal frequency would be:

$$F_x = 1.000 \text{ Mc} + 0.455 \text{ Mc} = 1.455 \text{ Mc.}$$

B. Where the signal frequency lies between 5.4 Mc and 16.0 Mc.

The crystal frequency is:

$$F_x = F_s + 3.955 \text{ Mc}$$

Example: For a 10 Mc signal the crystal frequency would be;

$$F_x = 10.000 \text{ Mc.} + 3.955 \text{ Mc.} = 13.955 \text{ Mc.}$$

C. Where the signal frequency lies between 16.0 Mc and 31.5 Mc.

The crystal frequency is:

$$F_x = \frac{F_s + 3.955}{2} =$$

Example: For a 25 Mc signal the crystal frequency would be;

$$F_x = \frac{25.000 + 3.955}{2} = \frac{28.955}{2}$$

$$F_x = 14.4775$$

where:  $F_x$  = Crystal frequency

$F_s$  = Signal frequency

#### NOTE

TO MINIMIZE CONFUSION BETWEEN THE CRYSTAL FREQUENCY AND THE SIGNAL FREQUENCY IT IS SUGGESTED THAT THE SIGNAL FREQUENCY BE NOTED ON THE IDENTIFICATION PLATE ADJACENT TO THE NUMBER IDENTIFYING THE CRYSTAL POSITION.

## SECTION III OPERATION

### 4.a. SINGLE SIDEBAND OPERATION (XTAL AND EXT)

The equations used to determine the HFO frequency places the received signal in the center of the IF bandpass. When receiving SSB the sideband signal utilizes only a portion of the IF bandpass. The HFO should, therefore, be shifted approximately one half the IF bandwidth; plus for

upper sideband or minus for lower sideband signals, so as to place the sideband in the center of the IF bandpass.

### 6. VARIABLE (NORMAL) OPERATION

The receiver is operated as described for AM, CW and SSB when the HFO switch is in the VAR position.

## 7. EXTERNAL OPERATION

A. Tune the receiver to the desired frequency with the HFO switch in the VAR position.

B. Peak the ANTENNA TUNE control.

C. Place the HFO switch in EXT position.

D. A slight retuning of the receiver may be necessary.

## 8. XTAL OPERATION

A. Tune the receiver as in paragraph 7.A above.

B. Select desired crystal with HFO switch.

C. Trim the XTAL ADJ control, if necessary.

D. A slight retuning of the receiver may be necessary.

TABLE 5-1a VOLTAGE CHART

TUBE	VAR. POS.	SOCKET PIN NUMBERS					
		1	2	3	4	5	6
V17 6AG5		0	0.8	3.2 AC	3.2 AC	70	90

TABLE 5-2a RESISTANCE CHART

TUBE	VAR. POS.	1	2	3	4	5	6
		V17 6AG5		120	120	50	50

## 5.a. ELECTRICAL PARTS LIST

SYM.	DESCRIPTION	FUNCTION & LOCATION	TMC PART NO.
C144	CAPACITOR, fixed: ceramic; 8 mmfd., $\pm 5\%$ ; 500 wvdc.	Plate Coupling S13	CC21CH080J
C145	CAPACITOR, fixed: ceramic; .01 mfd., $+80-20\%$ ; 500 wvdc.	Cathode Bias V17	CC-100-16
C146	CAPACITOR, fixed: ceramic; 47 mmfd., $\pm 10\%$ ; 500 wvdc.	Screen Bypass V17	CC21SL470K
C147	CAPACITOR, fixed: ceramic; .01 mfd., $+80-20\%$ ; 500 wvdc.	Screen Bypass V17	CC-100-16
C148	CAPACITOR, fixed: ceramic; .01 mfd., $+80-20\%$ ; 500 wvdc.	B+ Decoupling V17	CC-100-16
C149	CAPACITOR, variable: air dielectric; 1 section; 19 plates; 3.2 - 50 mmfd., 500 wvdc.	Xtal. Freq. Adj.	CT-104-1
J5	CONNECTOR, receptacle: electrical; 1 female contact; 52 ohms; BNC type.	EXT HFO Input	UG-625/U
L36	COIL, RF: 750 microhenries; $\pm 20\%$ ; 100 ma. max. current; DC resistance approx. 17 ohms; bakelite body.	RF Choke V17	CL-100-5

SYM.	DESCRIPTION	FUNCTION & LOCATION	TMC PART NO.
R98	RESISTOR, fixed: composition; 120 ohms, $\pm 10\%$ ; 1/2 watt.	Cathode Bias V17	RC20GF121K
R99	RESISTOR, fixed: composition; 47,000 ohms, $\pm 10\%$ ; 1/2 watt.	Grid Res. V17	RC20GF473K
R100	RESISTOR, fixed: composition; 47 ohms, $\pm 10\%$ ; 1/2 watt.	Parasitic Supp. V17	RC20GF470K
R101	RESISTOR, fixed: composition; 22,000 ohms, $\pm 10\%$ ; 1 watt.	Plate Load V17	RC30GF223K
R102	RESISTOR, fixed: composition; 1,000 ohms, $\pm 10\%$ ; 1/2 watt.	B+ Decoupling V17	RC20GF102K
R103	RESISTOR, fixed: composition; 22,000 ohms, $\pm 10\%$ ; 1/2 watt.	Screen Res. V17	RC20GF223K
R104	RESISTOR, fixed: composition; 68 ohms, $\pm 10\%$ ; 2 watts.	EXT Input Res. J5	RC42GF680K
S12A, B	SWITCH, rotary: shorting; two sections; single pole; twelve positions; 30 deg angle of throw; Mycalex insulation; silver plated brass contacts and wipers; 1/4 in. diam shaft, 7/8 in. lg. from mtg. surface.	HFO Switch	SW-202
S13	SWITCH, rotary: non-shorting; one section; single pole; two positions; 30 deg. angle of throw; glass melamine insulation; silver alloy contacts and wipers; 1/8 in. diam shaft flated, 19/32 in. lg. from mtg. surface.	p/o HFO Switch	SW-203
V17	TUBE, electron: sharp cutoff RF pentode; 7 pin miniature.	Ampl. Xtal Osc.	6AG5
XV17	SOCKET, electron tube: 7 pin miniature.	Socket for V17	TS102P01
XY4 thru 13	SOCKET, crystal: .486" spacing for .050" pin diam.	Socket for Y4 thru Y13	TS-104-1
Y4 thru Y13	CRYSTAL UNIT: quartz: parallel resonance: .995 to 2 Mc., $\pm .005\%$ . (Supplied only on customers request)	HFO Xtal	CR-18/U

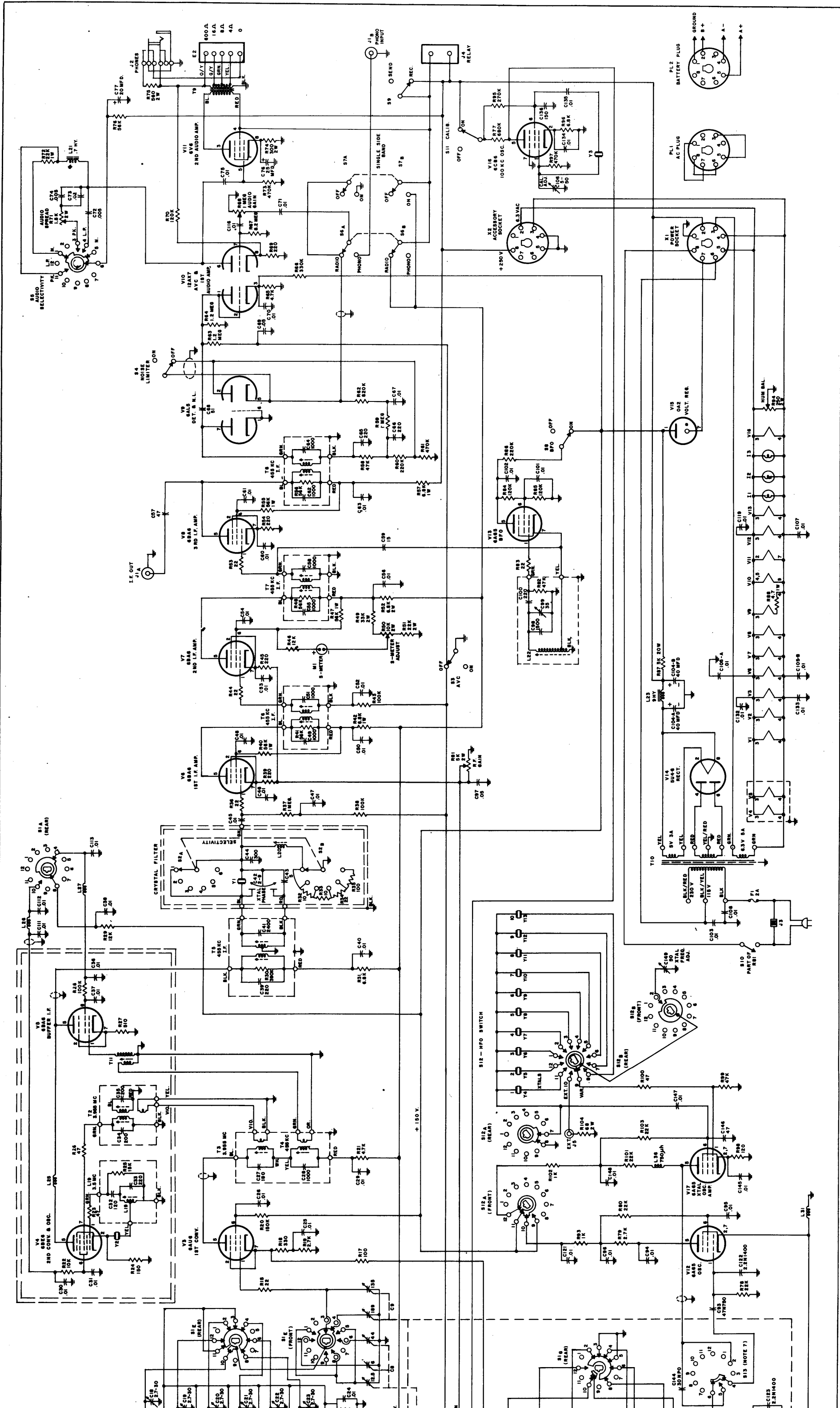

Schematic Diagram, Model GPR-90-RX

BAND	TUNING RANGE
1	.54 - 1.4 MC
2	1.4 - 3.3 MC
3	3.2 - 5.6 MC
4	5.4 - 9.7 MC
5	9.4 - 17.8 MC
6	17.3 - 31.5 MC

S1 - RANGE SELECTOR SWITCH

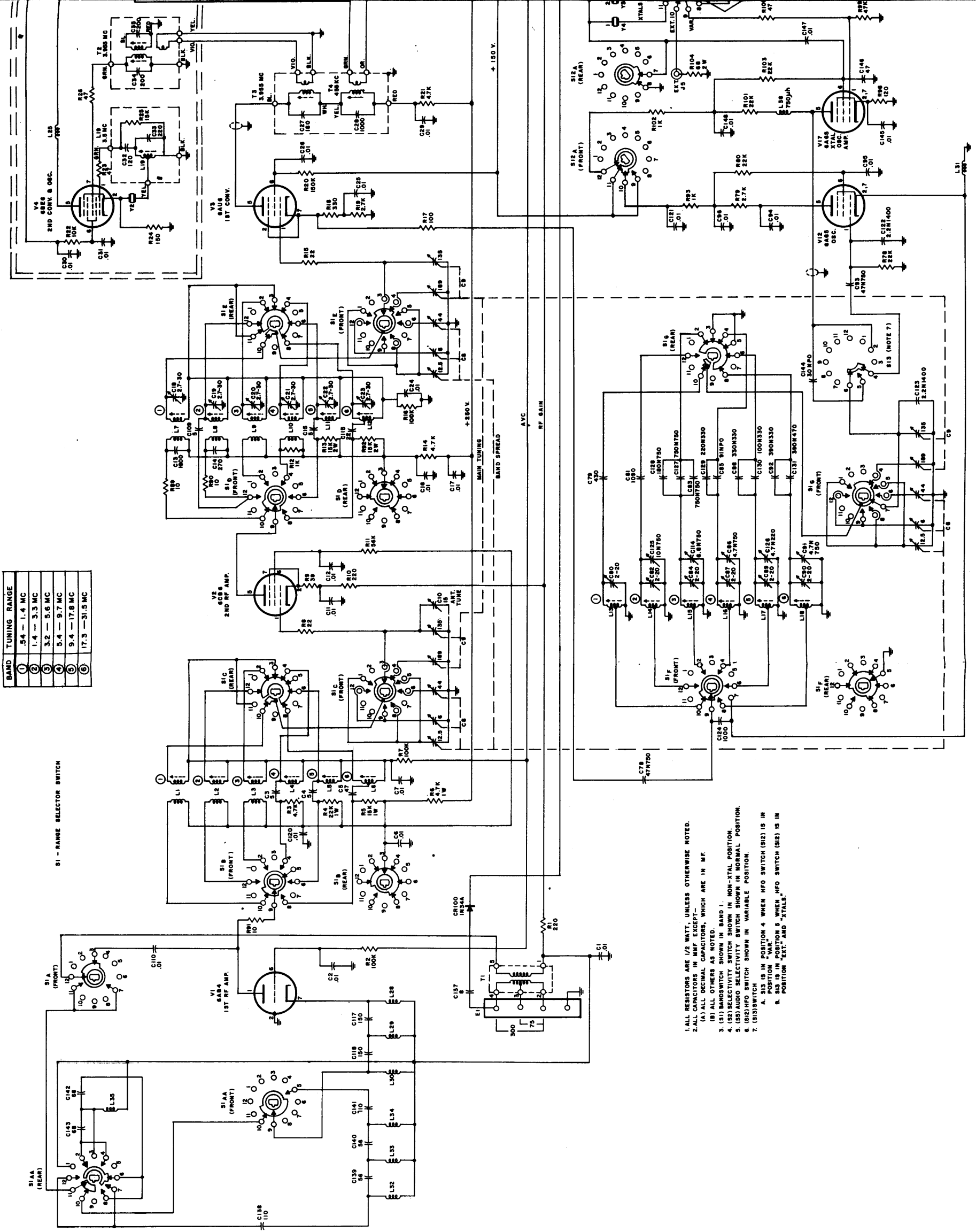

1. ALL RESISTORS ARE 1/2 WATT, UNLESS OTHERWISE NOTED.
2. ALL CAPACITORS IN MMF EXCEPT—
  - (A) ALL DECIMAL CAPACITORS, WHICH ARE IN MF.
  - (B) ALL OTHERS AS NOTED.
3. (S1) BANDSWITCH SHOWN IN BAND 1.
4. (S2) SELECTIVITY SWITCH SHOWN IN NON-XTAL POSITION.
5. (S3) AUDIO SELECTIVITY SWITCH SHOWN IN NORMAL POSITION.
6. (S1) SWITCH POSITION SHOWN IN VARIABLE POSITION.
  - A. S1 IS IN POSITION 4 WHEN MFO SWITCH (S12) IS IN POSITION "VAR."
  - B. S1 IS IN POSITION 5 WHEN MFO SWITCH (S12) IS IN POSITION "EXT. AND XTALS."