

UNCLASSIFIED

TECHNICAL MANUAL

for

CONTROL SYNTHESIZER
AND STANDARD

MODEL HFS-1

(0-941/UR)



THE TECHNICAL MATERIEL CORPORATION

MAMARONECK, N. Y.

OTTAWA, CANADA

★

UNCLASSIFIED

TECHNICAL MANUAL

for

**CONTROL SYNTHESIZER
AND STANDARD**

MODEL HFS-1

(0-941/UR)



THE TECHNICAL MATERIEL CORPORATION

MAMARONECK, N. Y.

OTTAWA, CANADA

★

IN-3001B

Issue Date: 15 April 1963
Revised: 15 Sept 1695

NOTICE

THE CONTENTS AND INFORMATION CONTAINED IN THIS INSTRUCTION MANUAL IS PROPRIETARY TO THE TECHNICAL MATERIEL CORPORATION TO BE USED AS A GUIDE TO THE OPERATION AND MAINTENANCE OF THE EQUIPMENT FOR WHICH THE MANUAL IS ISSUED AND MAY NOT BE DUPLICATED EITHER IN WHOLE OR IN PART BY ANY MEANS WHATSOEVER WITHOUT THE WRITTEN CONSENT OF THE TECHNICAL MATERIEL CORPORATION.



THE TECHNICAL MATERIEL CORPORATION

C O M M U N I C A T I O N S E N G I N E E R S

700 FENIMORE ROAD

MAMARONECK, N. Y.

Warranty

The Technical Materiel Corporation, hereinafter referred to as TMC, warrants the equipment (except electron tubes,* fuses, lamps, batteries and articles made of glass or other fragile or other expendable materials) purchased hereunder to be free from defect in materials and workmanship under normal use and service, when used for the purposes for which the same is designed, for a period of one year from the date of delivery F.O.B. factory. TMC further warrants that the equipment will perform in a manner equal to or better than published technical specifications as amended by any additions or corrections thereto accompanying the formal equipment offer.

TMC will replace or repair any such defective items, F.O.B. factory, which may fail within the stated warranty period, PROVIDED:

1. That any claim of defect under this warranty is made within sixty (60) days after discovery thereof and that inspection by TMC, if required, indicates the validity of such claim to TMC's satisfaction.
2. That the defect is not the result of damage incurred in shipment from or to the factory.
3. That the equipment has not been altered in any way either as to design or use whether by replacement parts not supplied or approved by TMC, or otherwise.
4. That any equipment or accessories furnished but not manufactured by TMC, or not of TMC design shall be subject only to such adjustments as TMC may obtain from the supplier thereof.

Electron tubes* furnished by TMC, but manufactured by others, bear only the warranty given by such other manufacturers. Electron tube warranty claims should be made directly to the manufacturer of such tubes.

TMC's obligation under this warranty is limited to the repair or replacement of defective parts with the exceptions noted above.

At TMC's option any defective part or equipment which fails within the warranty period shall be returned to TMC's factory for inspection, properly packed with shipping charges prepaid. No parts or equipment shall be returned to TMC, unless a return authorization is issued by TMC.

No warranties, express or implied, other than those specifically set forth herein shall be applicable to any equipment manufactured or furnished by TMC and the foregoing warranty shall constitute the Buyers sole right and remedy. In no event does TMC assume any liability for consequential damages, or for loss, damage or expense directly or indirectly arising from the use of TMC Products, or any inability to use them either separately or in combination with other equipment or materials or from any other cause.

*Electron tubes also include semi-conductor devices.

PROCEDURE FOR RETURN OF MATERIAL OR EQUIPMENT

Should it be necessary to return equipment or material for repair or replacement, whether within warranty or otherwise, a return authorization must be obtained from TMC prior to shipment. The request for return authorization should include the following information:

1. Model Number of Equipment.
2. Serial Number of Equipment.
3. TMC Part Number.
4. Nature of defect or cause of failure.
5. The contract or purchase order under which equipment was delivered.

PROCEDURE FOR ORDERING REPLACEMENT PARTS

When ordering replacement parts, the following information must be included in the order as applicable:

1. Quantity Required.
2. TMC Part Number.
3. Equipment in which used by TMC or Military Model Number.
4. Brief Description of the Item.
5. The *Crystal Frequency* if the order includes crystals.

PROCEDURE IN THE EVENT OF DAMAGE INCURRED IN SHIPMENT

TMC's Warranty specifically excludes damage incurred in shipment to or from the factory. In the event equipment is received in damaged condition, the carrier should be notified immediately. Claims for such damage should be filed with the carrier involved and not with TMC.

All correspondence pertaining to Warranty Claims, return, repair, or replacement and all material or equipment returned for repair or replacement, within Warranty or otherwise, should be addressed as follows:

THE TECHNICAL MATERIEL CORPORATION
Engineering Services Department
700 Fenimore Road
Mamaroneck, New York



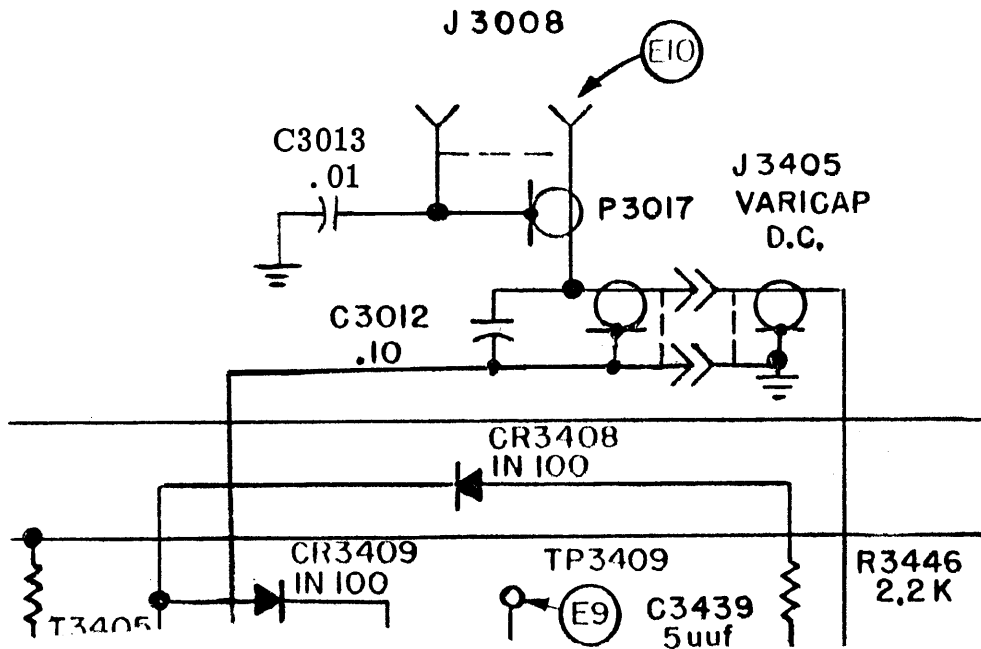
INSTRUCTION BOOK CHANGE NOTICE

Date 10/5/65

Manual affected: Control Synthesizer and Standard IN -3001B
Model HFS-1 (Rev. Date: 15 Sept. 1965)

Page 8-5/8-6, Figure 8-1 (Sheet 2 of 3).

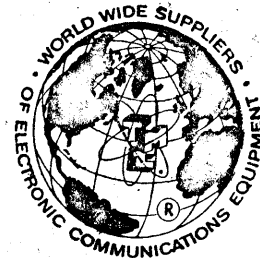
Add C3013 at .01 mfd to J3008 circuitry as shown below.



SHOULD ADDITIONAL COPIES OF THIS CHANGE NOTICE BE REQUIRED, PLEASE CONTACT:

THE TECHNICAL MATERIEL CORP., 700 Fenimore Road, Mamaroneck, New York

Attn.: Director of Eng. Services.



INSTRUCTION BOOK CHANGE NOTICE

Date 12/21/65

Manual affected: Control Synthesizer and Standard IN - 3001B
Model HFS-1 (Revision Date: 15 Sept 1965)

Page 4-3/4-4. Figure 4-2.

Change figure 4-2 to include 250-kc regenerative divider circuitry as indicated below:

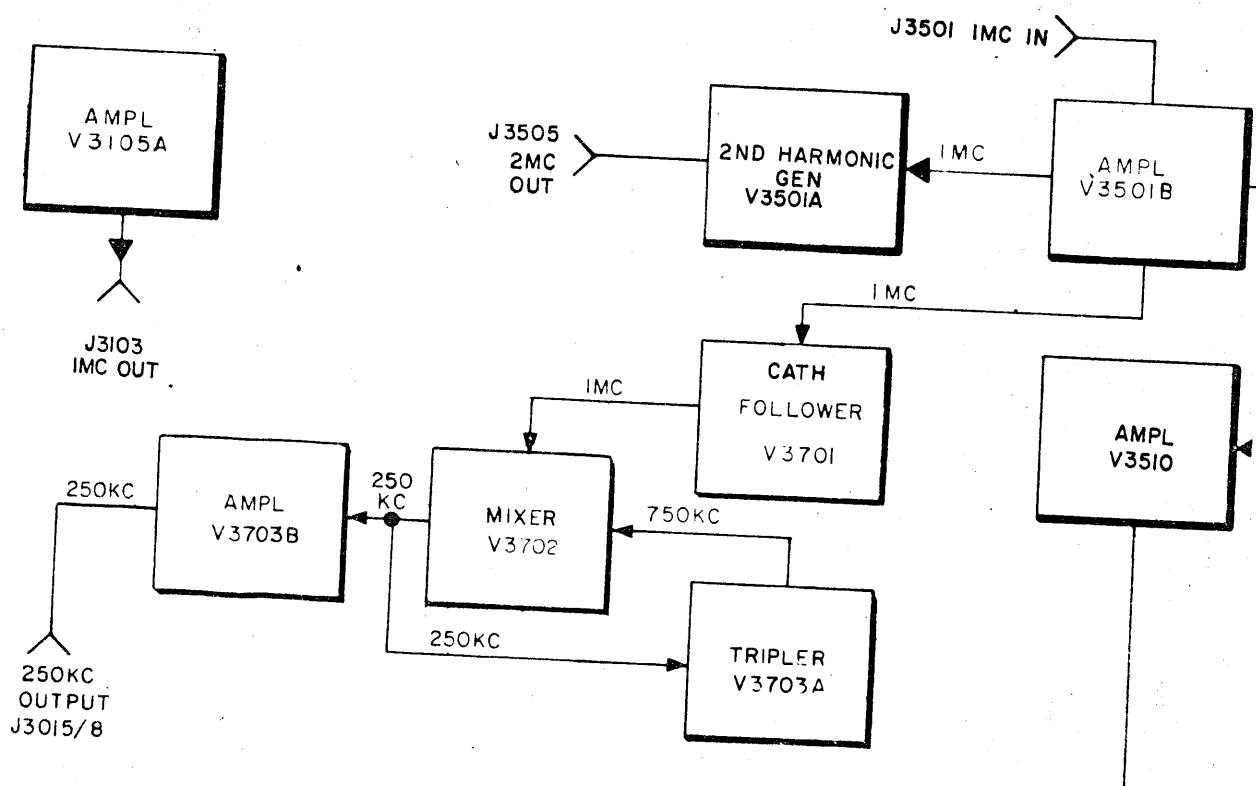


TABLE OF CONTENTS

Paragraph	Page	Paragraph	Page
SECTION 1—GENERAL INFORMATION		SECTION 4—PRINCIPLES OF OPERATION (Cont'd)	
1-1	Purpose of Equipment	1-1	
1-2	Description of Equipment	1-1	
1-3	Electrical Characteristics	1-1	
1-4	Mechanical Characteristics	1-1	
1-5	Electron Tube and Diode Complement	1-1	
SECTION 2—INSTALLATION		4-7 Detailed Circuit Analysis of 3500-3600 Deck 4-18	
2-1	Initial Inspection	2-1	
2-2	Mechanical Installation	2-1	
2-3	Electrical Installation	2-1	
2-4	Preoperational Checkout	2-1	
SECTION 3—OPERATOR'S SECTION		4-8 Detailed Circuit Analysis of 3700 Deck 4-18	
3-1	Operating Controls	3-1	
3-2	Sequence of Operation	3-1	
3-3	External 1-Mc Source	3-2	
3-4	Operator's Maintenance	3-2	
SECTION 4—PRINCIPLES OF OPERATION		4-9 Main Chassis (3000 Deck) Description 4-23/4-24	
4-1	Simplified Block Diagram Analysis	4-1	
4-2	Detailed Block Diagram Analysis	4-2	
4-3	Detailed Circuit Analysis of 3100 Deck	4-6	
4-4	Detailed Circuit Analysis of 3200 Deck	4-8	
4-5	Detailed Circuit Analysis of 3300 Deck	4-8	
4-6	Detailed Circuit Analysis of 3400 Deck	4-11	
		SECTION 5—TROUBLESHOOTING	
		5-1 General 5-1	
		5-2 Test Equipment Needed 5-1	
		5-3 Unit Troubleshooting 5-2	
		5-4 Functional Section Trouble- shooting 5-7	
		SECTION 6—MAINTENANCE	
		6-1 Introduction 6-0	
		6-2 Preventive Maintenance 6-0	
		6-3 Corrective Maintenance 6-0	
		6-4 Alignment of 3100 Deck 6-1	
		6-5 Alignment of 3200 Deck 6-1	
		6-6 Alignment of 3300 Deck 6-2	
		6-7 Alignment of 3500 Deck 6-3	
		6-8 Alignment of 3400 Deck 6-6	
		6-9 Alignment of 3700 Deck 6-7	
		SECTION 7—PARTS LIST	
		7-1 Parts List 7-1	
		SECTION 8—SCHEMATIC DIAGRAMS	
		8-1 Schematic Diagrams 8-1/8-2	

LIST OF ILLUSTRATIONS

Figure	Page	Figure	Page
SECTION 1—GENERAL INFORMATION		SECTION 4—PRINCIPLES OF OPERATION	
1-1	iv	(Cont'd)	
The HFS-1 Control Synthesizer and Standard		4-12	4-23/4-24
SECTION 2—INSTALLATION		4-13	3500-3600 Deck, Simplified Schematic Diagram (Sheet 1 of 2)
2-1	2-2	4-13	4-25/4-26
HFS-1, Outline Dimensional Drawing		4-13	3500-3600 Deck, Simplified Schematic Diagram (Sheet 2 of 2)
2-2	2-2	4-14	4-27/4-28
HFS-1, Interconnection Diagram		4-14	Regenerative Divider (High Frequency Loop)
SECTION 3—OPERATOR'S SECTION		4-15	4-29/4-30
3-1	3-2	4-15	Typical Nixie Indicator Connection
HFS-1, Front Panel Controls			4-29/4-30
SECTION 4—PRINCIPLES OF OPERATION		SECTION 5—TROUBLESHOOTING	
4-1	4-1	5-1	HFS-1, Top View Showing Test Points
4-2	4-3/4-4	5-2	5-14
HFS-1, Block Diagram		5-2	HFS-1, Bottom View Showing Decks
4-3	4-6		5-15
Simplified Schematic of Typical Phantastron and Accompanying Waveforms		SECTION 6—MAINTENANCE	
4-4	4-7	6-1	Identification of Piston Capacitors on 3500 Deck
1-Mc Frequency Standard Schematic Diagram Part of 3100 Deck		6-2	6-4
4-5	4-9/4-10	6-2	Identification of Piston Capacitors on 3400 Deck
3100 Deck, Simplified Schematic			6-5
4-6	4-11	SECTION 8—SCHEMATIC DIAGRAMS	
Balanced Modulator and Waveforms		8-1	HFS-1 Schematic Diagram (Sheet 1 of 3)
4-7	4-13/4-14	8-1	8-3/8-4
3200 Deck, Simplified Schematic		8-1	HFS-1 Schematic Diagram (Sheet 2 of 3)
4-8	4-15/4-16	8-1	8-5/8-6
3300 Deck, Simplified Schematic		8-1	HFS-1 Schematic Diagram (Sheet 3 of 3)
4-9	4-17		8-7/8-8
Multivibrator Circuit and Waveforms			
4-10	4-17		
Block Oscillator and Waveforms			
4-11	4-19/4-20		
3400 Deck, Simplified Schematic (Sheet 1 of 2)			
4-11	4-21/4-22		
3400 Deck, Simplified Schematic (Sheet 2 of 2)			

LIST OF TABLES

Table	Page	Table	Page
SECTION 1—GENERAL INFORMATION		SECTION 5—TROUBLESHOOTING	
1-1	1-2	5-1	5-1
			5-2
SECTION 2—INSTALLATION		5-2	5-2
2-1	2-1	5-3	5-2
2-2	2-3		5-3
2-3	2-3	5-4	5-3
2-4	2-4	5-5	5-6
2-5	2-4	5-6	5-6
2-6	2-5		5-7
SECTION 3—OPERATOR'S SECTION		SECTION 6—MAINTENANCE	
3-1	3-1	6-1	6-0
SECTION 4—PRINCIPLES OF OPERATION		6-2	6-1
4-1	4-2	6-3	6-2
4-2	4-6	6-4	6-2
		6-5	6-3
		6-6	6-6
		6-7	6-6
		6-8	6-6
		6-9	6-7



3001B-1

Figure 1-1. The HFS-1 Control Synthesizer and Standard

SECTION 1 GENERAL INFORMATION

1-1. PURPOSE OF EQUIPMENT.

The HFS-1 Control Synthesizer and Standard is a frequency synthesizer designed to operate with receivers in a 2 to 32 mc band. In systems such as the DDR-5, the HFS-1 is not used as a source of an oscillator frequency, but rather as a comparator that provides a dc correction voltage to stabilize a local oscillator such as that found in the HFR-1 Continuous RF Tuner.

1-3. ELECTRICAL CHARACTERISTICS.

Stability

RF Input from HFR-1 or HFF-1

Outputs

Meters and Indicators

Inputs Power

1-4. MECHANICAL CHARACTERISTICS.

Dimensions . . 19" x 20-1/4" x 10-1/2"

Weight 43 lbs.

1-2. DESCRIPTION OF EQUIPMENT.

The HFS-1 is a frequency synthesizer with a built-in oven controlled frequency standard that has a minimum accuracy of one part in 10^8 for a 24-hour period. It consists basically of a high-frequency loop and a basic synthesizer unit which provides the dc correction voltage to stabilize the local oscillator frequency of a receiver. The frequency being received is displayed by the front panel nixie indicators. The HFS-1 tunes between 2 and 32 mc, in 100-cycle steps.

10^8 for a 24-hour period.

3.75 to 33.75 mc at a level not greater than 10 millivolts.

- a. ± 3 vdc which is proportional to the phase difference between the input signal and the reference oscillator.
- b. Four 2-mc, 1-volt, outputs. Two high impedance and two low impedance.
- c. Four 250-kc outputs providing at least 1 volt into 25 ohms. Two high impedance and two low impedance.
- d. 1 mc, 1 volt, across 50 ohms.
- e. Audio output (frequency difference between input signal and internal reference).
- f. Sync indication control for HFR-1 or HFA-1 units.

Digital frequency readout and 1-mc phase comparator.

+28 vdc at 1 amp; +200 vdc; 6.3 vac, 60 cps.

1-5. ELECTRON TUBE AND DIODE COMPLEMENT.

The electron tubes and diodes comprising the HFS-1 are listed in table 1-1.

TABLE 1-1. ELECTRON TUBE AND DIODE COMPLEMENT

REFERENCE SYMBOL		
SEMICONDUCTOR DEVICES	TYPE	FUNCTION
CR3101, CR3102, CR3103, CR3201, CR3203, CR3204, CR3301, CR3403, CR3412, CR3413, CR3415, CR3416	1N463	
CR3202, CR3302	DD-100	
CR3303, CR3304	1N303	
CR3401, CR3402, CR3404, CR3405, CR3406, CR3407	1N100	
CR3414	1N2845B	
Q3002	2N697	
TUBES		
V3101, V3201, V3301, V3402	6AS6	Divider
V3102	6AB4	Amplifier
V3103, V3104, V3204, V3304, V3512	6AU6	Amplifier
V3105	6AW8A	Amplifier/Comparator
V3202, V3302, V3701	6AB4	Cathode Follower
V3203, V3303, V3404, V3405, V3406	6AH6	Amplifier
V3401	12AU7	Multivibrator/Amplifier
V3403	12AT7	Amplifier/Cathode Follower
V3501	6AW8	Harmonic Generator/ Amplifier
V3502	6EW6	Oscillator
V3503	6AB4	Pulse Generator
V3504, V3507, V3508, V3509, V3510	6AK5	Amplifier
V3511	6BE6	Converter
V3506	6AK5	Converter
V3505	6S4	Converter
V3702	6CS6	Converter
V3703	6U8A	Amplifier/Converter

SECTION 2 INSTALLATION

2-1. INITIAL INSPECTION.

Each HFS-1 unit has been calibrated and tested at the factory before shipment. Upon arrival at the operating site, inspect the packing case and contents for possible damage. Unpack the equipment carefully. Inspect all packing material for parts which may have been shipped as "loose item." With respect to damage to the equipment for which the carrier is liable, the Technical Materiel Corporation will assist in describing methods of repair and the furnishing of replacement parts.

The equipment is shipped with all tubes and other plug-in components installed. Check that all such components are properly seated in their sockets.

2-2. MECHANICAL INSTALLATION.

The HFS-1 is designed for rack mounting will all power and audio connections made to the rear. De-

signed with a standard 19-inch rack panel, the HFS-1's outline dimension drawing is shown in figure 2-1.

The HFS-1 can be supplied with slides for mounting in a suitable housing. To install an HFS-1 equipped with slides, set it in position on the tracks until the release buttons catch. Press the release buttons and push the HFS-1 into the equipment rack until the release buttons engage the holes in the equipment. After this, secure the front panel to the equipment rack with screws.

2-3. ELECTRICAL INSTALLATION.

All necessary input and output connections for the HFS-1 are shown in figure 2-2. The power interconnect cable is connected to jack J3001 at the rear of the unit. All signal inputs and outputs are also connected at the rear of the equipment. Refer to table 2-1, below, and figure 2-2 before making connections.

TABLE 2-1. INPUT AND OUTPUT CONNECTIONS

INPUT OR OUTPUT DESIRED:	CONNECT TO:
Use of internal 1-mc standard	J3019
Use of external 1-mc standard	J3020
250-kc outputs	J3015, J3016, J3017, J3018
Audio sync tone output	J3014
2-mc outputs	J3010, J3011, J3012, J3013
Oscillator control voltage (varicap dc out)	J3008
HFO output	J3009

2-4. PREOPERATIONAL CHECKOUT.

After properly installing the HFS-1 into the system, perform the following to simultaneously check the synthesizer and HFO tracking for all positions of the nixie selector switches.

a. Remove the 47-ohm termination from J1313 on the HFR-1 Continuous RF Tuner and connect a frequency counter to this jack.

b. Set HFS-1 to 02.000000 and the RF tuner to 2 mc. Place TUNE-SYNC-OPERATE switch in SYNC position.

c. Move the TUNE control about 2.0 mc until the sync tone is heard; adjust TUNE control to a zero beat. The SYNC IND light Relay may chatter during this operation. Place the TUNE-SYNC-OPERATE in OPERATE. The SYNC IND lamp should light. The counter should read 3.75 mc. Return the TUNE-SYNC-OPERATE switch to the SYNC position.

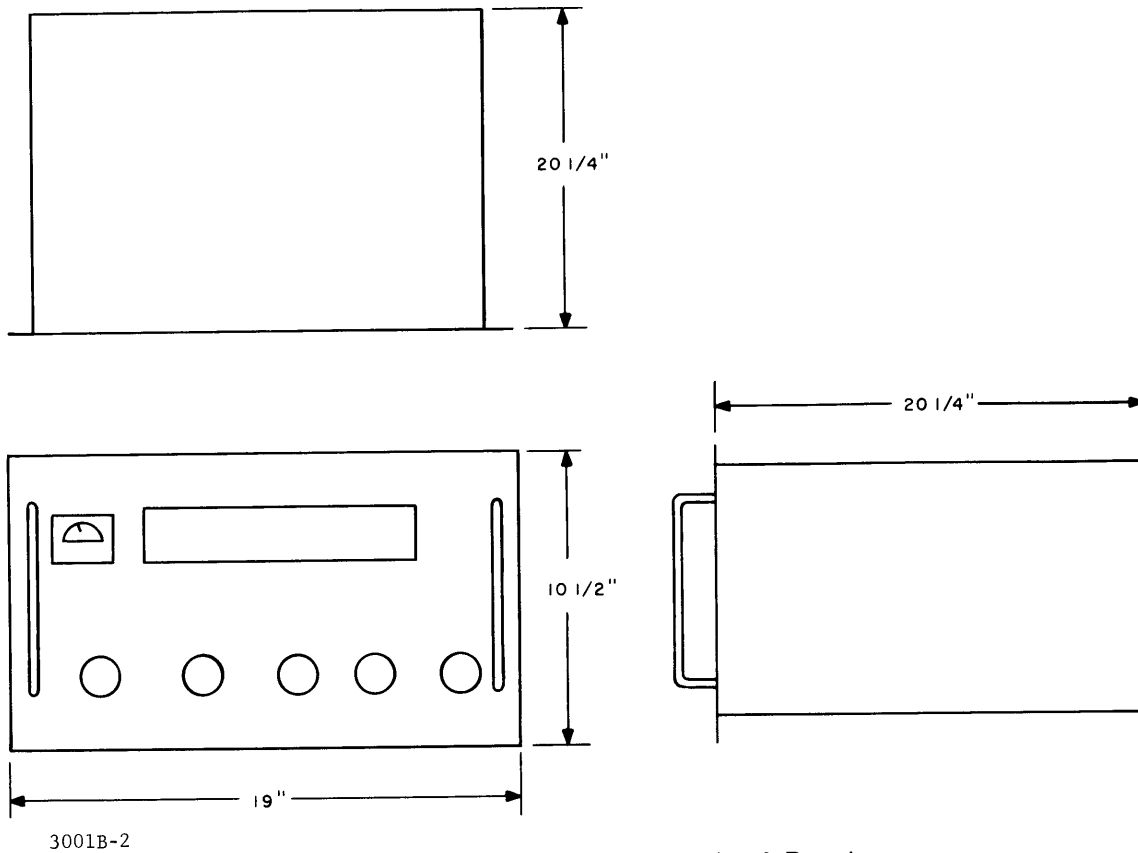


Figure 2-1. HFS-1, Outline Dimensional Drawing

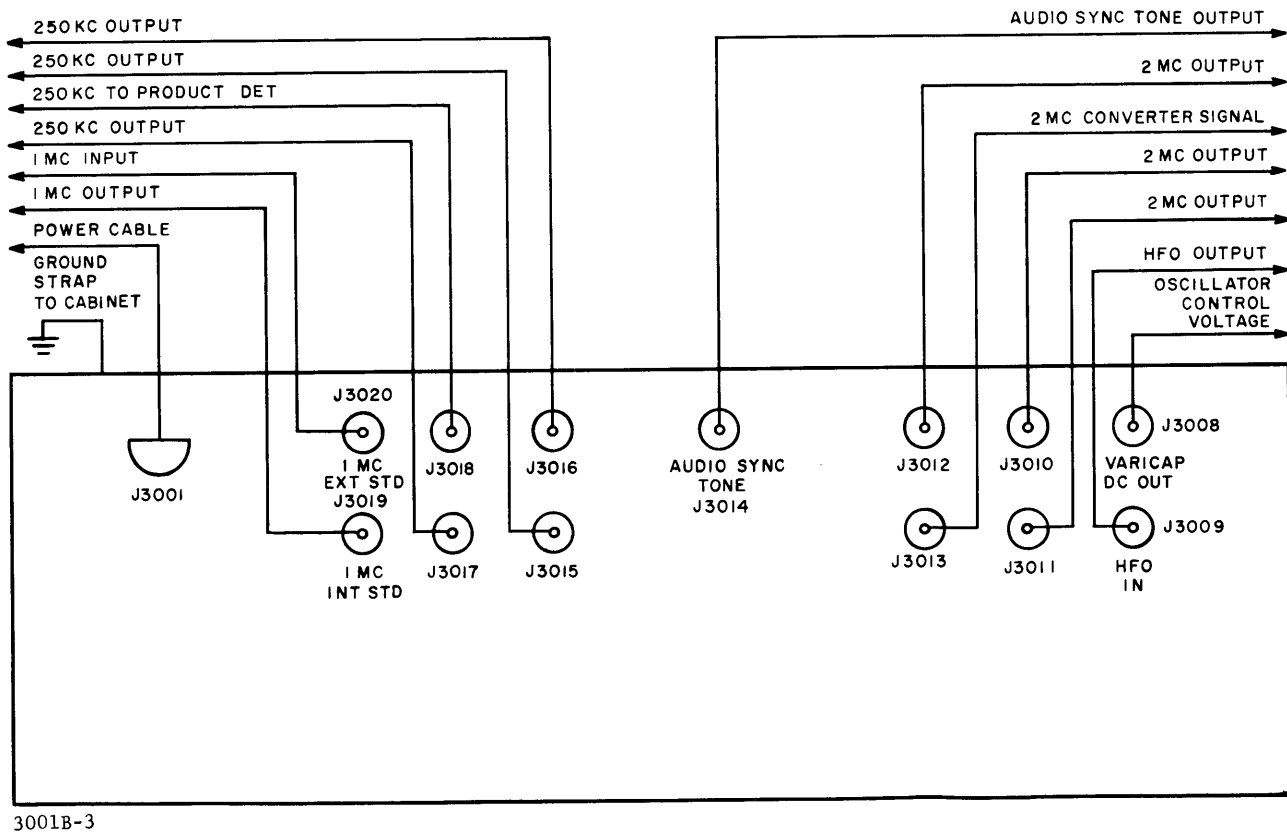


Figure 2-2. HFS-1, Interconnection Diagram

d. Place 100 KC switch in "1" position and move the TUNE control until a zero beat is obtained at 2.1 mc. Place TUNE-SYNC-OPERATE switch in OPERATE. The counter should read 3.85 mc. Return the TUNE-SYNC-OPERATE switch to the SYNC position.

e. Continue this procedure through the remaining positions of the 100 KC selector switch. For each position move the TUNE control to obtain a zero beat as indicated in table 2-2, below.

TABLE 2-2. 100 KC SELECTOR AND FREQUENCIES

100 KC SELECTOR POSITION	TUNE CONTROL SET TO: (MC)	COUNTER SET TO: (MC)
2	2.2	3.95
3	2.3	4.05
4	2.4	4.15
5	2.5	4.25
6	2.6	4.35
7	2.7	4.45
8	2.8	4.55
9	2.9	4.65

f. Place the 10 KC selector switch in position "1" and adjust the TUNE control to obtain a zero beat at 2.91 mc. Place the TUNE-SYNC-OPERATE switch in OPERATE. The counter should now read 4.66 mc. Put TUNE-SYNC-OPERATE switch in SYNC position.

g. Continue this procedure through the remaining positions of the 10 KC selector switch. For each position, move the TUNE control to obtain a zero beat as indicated in table 2-3, below.

TABLE 2-3. 10 KC SELECTOR AND FREQUENCIES

10 KC SELECTOR POSITION	TUNE CONTROL SET TO: (MC)	COUNTER SET TO: (MC)
2	2.92	4.67
3	2.93	4.68
4	2.94	4.69
5	2.95	4.70
6	2.96	4.71
7	2.97	4.72
8	2.98	4.73
9	2.99	4.74

h. Place the 1 KC selector in position "1" and adjust TUNE control until a zero beat is obtained at 2.991 mc. The counter should read 4.741 mc. Return the TUNE-SYNC-OPERATE switch to the SYNC position.

i. Continue this procedure through the remaining positions of the 1 KC selector switch. For each position, move the TUNE control to obtain a zero beat as indicated in table 2-4, below.

TABLE 2-4. 1 KC SELECTOR AND FREQUENCIES

1 KC SELECTOR POSITION	TUNE CONTROL SET TO: (MC)	COUNTER SET TO: (MC)
2	2.992	4.742
3	2.993	4.743
4	2.994	4.744
5	2.995	4.745
6	2.996	4.746
7	2.997	4.747
8	2.998	4.748
9	2.999	4.749

j. Place the .1 KC selector switch in position "1" and adjust TUNE control until a zero beat is obtained at 2.9991 mc. Place the TUNE-SYNC-OPERATE switch in OPERATE position. The counter should read 4.7491 mc. Return the TUNE-SYNC-OPERATE switch to the SYNC position.

k. Continue this procedure for the remaining positions of the .1 KC selector switch. For each position move the TUNE control to obtain a zero beat as indicated in table 2-5, below.

TABLE 2-5. .1 KC SELECTOR AND FREQUENCIES

.1 KC SELECTOR POSITION	TUNE CONTROL SET TO: (MC)	COUNTER SET TO: (MC)
2	2.9992	4.7492
3	2.9993	4.7493
4	2.9994	4.7494
5	2.9995	4.7495
6	2.9996	4.7496
7	2.9997	4.7497
8	2.9998	4.7498
9	2.9999	4.7499

l. Tune the synthesizer to 03.000000. Move the TUNE control to obtain a zero beat at 3 mc. Place the TUNE-SYNC-OPERATE switch in SYNC position.

m. Place BAND control in Band 2 position (3-4-mc). Adjust the TUNE control to obtain a zero beat at 3 mc. Place the TUNE-SYNC-OPERATE switch in OPERATE position. The counter should indicate

4.75 mc. Return the TUNE-SYNC-OPERATE switch to the SYNC position.

n. Continue this procedure for the remaining positions of the 1 MC selector switch, conducting the check at the high and low ends of each band. In each case; the counter should read 1.75 mc above the selected frequency when the TUNE-SYNC-OPERATE switch is placed in the OPERATE position. See table 2-6, below.

TABLE 2-6. 1 MC SELECTOR AND FREQUENCIES

1 MC SELECTOR POSITION	BAND	TUNE CONTROL SET TO: (MC)	COUNTER SET TO: (MC)
4	2	4	5.75
4	3	4	5.75
5	3	5	6.75
6	3	6	7.75
6	4	6	7.75
7	4	7	8.75
8	4	8	9.75
8	5	8	9.75
9	5	9	10.75
10	5	10	11.75
11	5	11	12.75
12	5	12	13.75
12	6	12	13.75
13	6	13	14.75
14	6	14	15.75
15	6	15	16.75
16	6	16	17.75
16	7	16	17.75
17	7	17	18.75
18	7	18	19.75
19	7	19	20.75
20	7	20	21.75
21	7	21	22.75
22	7	22	23.75
23	7	23	24.75

TABLE 2-6. 1 MC SELECTOR AND FREQUENCIES (CONT'D)

1 MC SELECTOR POSITION	BAND	TUNE CONTROL SET TO: (MC)	COUNTER SET TO: (MC)
24	8	24	25.75
24	8	24	25.75
25	8	25	26.75
26	8	26	27.75
27	8	27	28.75
28	8	28	29.75
29	8	29	30.75
30	8	30	31.75
31	8	31	32.75

o. To tune synthesizer to 15.000000; set BAND control of HFR-1 to BAND 6, and TUNE control to 15 mc. With the TUNE-SYNC-OPERATE switch at SYNC, obtain a zero beat. Place TUNE-SYNC-OPERATE in OPERATE. Carefully move the tune control until the SYNC IND light goes out; at this point the sync meter should return to the center of its scale $\pm 1/8$ inch. Tune synthesizer to 14.9999

the band control band 6 (12-18-mc), and the TUNE control to 14.9999 mc. With the TUNE-SYNC-OPERATE switch in SYNC obtain a zero beat. Place the TUNE-SYNC-OPERATE switch in OPERATE and repeat the proceeding tuning procedure to see if the SYNC needle will return to center scale $\pm 1/8$ inch.

p. Remove the counter from J1313 and replace 47-ohm termination.

SECTION 3 OPERATOR'S SECTION

3-1. OPERATING CONTROLS.

Table 3-1 indicates the component designations and functions of the front panel controls. See figure 3-1 and refer to this table.

3-2. SEQUENCE OF OPERATION.

If the equipment has been shut down for a considerable period of time, the ovens should be allowed to warm up before synthesized operation is attempted. A 24-hour period is ideal; however, proper operation can be expected after an initial warm-up of six hours. The system can be operated with a shorter warm up period if there is an operator on duty. To set the synthesizer in operation, perform the following:

a. Rotate the selector switches until desired frequency is indicated by nixies. For a frequency of 2 mc, for example, the indicators will read 02.000000.

b. Place the TUNE-SYNC-OPERATE switch on the RF tuner to the SYNC position. As the TUNE control is carefully moved to shift the dial pointer around 2 mc, an audio tone will be heard. The TUNE control is then adjusted for a zero beat. The SYNCHRONIZE indicator Relay on the HFS-1 may chatter during this operation.

c. The TUNE-SYNC-OPERATE switch is then placed in the OPERATE position. The SYNC IND will light and the SYNCHRONIZE meter will indicate approximately zero center scale.

d. Carefully move the TUNE control to bring the SYNCHRONIZE meter to zero center scale, then lock the TUNE control with the locking device. The system should now be operating synthesized at 2 mc.

TABLE 3-1. OPERATING CONTROLS

REFERENCE DESIGNATION	PANEL AND COMPONENT DESIGNATION	FUNCTION
1	.1 KC switch S3101	Tunes the synthesizer in 100-cycle steps.
2	1 KC switch S3201	Tunes the synthesizer in 1000-cycle steps.
3	10 KC switch S3301	Tunes the synthesizer in 10-kc steps.
4	100 KC switch S3401	Tunes the synthesizer in 100-kc steps.
5	1 MC switch S3501	Tunes the synthesizer in 1-mc steps between 2 and 32-mc.
6	1 MC COMPARATOR meter M3001	Indicates frequency error in internal 1-mc standard.
7	Nixie frequency indicator	Indicates with nixies the frequency of incoming signals.

3-3. EXTERNAL 1-MC SOURCE.

Normally the internally generated 1-mc source is used as the basic reference frequency for the synthesizer. However, should you want to use an external 1-mc signal instead of the internally generated one, throw Internal-External Switch S3102 into the External position. S3102 is located on the top right side of the chassis. However, when using an external 1-mc source, make sure that the stability of the signal is at least that of the internal source. (-1 part in 10^8 per 24-hour period.) By using a 1-mc source with a stability greater than the internal source, the error of the internal source can be determined. The external 1-mc source is connected to 1-mc ext jack

J3020 at the rear of the equipment. The 1 MC COMPARATOR meter (M3001), located on the front panel, shows the error in cycles per second. If one complete swing occurs in 5 seconds, the error is $1/5$ cycle.

3-4. OPERATOR'S MAINTENANCE.

If any malfunction occurs, immediately turn off equipment and visually inspect the equipment for simple defects. If conditions warrant, see the troubleshooting section (Section 5) of this manual. The operator should specifically observe whether the tubes, dial, and meter are functioning properly. Make sure, also, that all parts are clean.

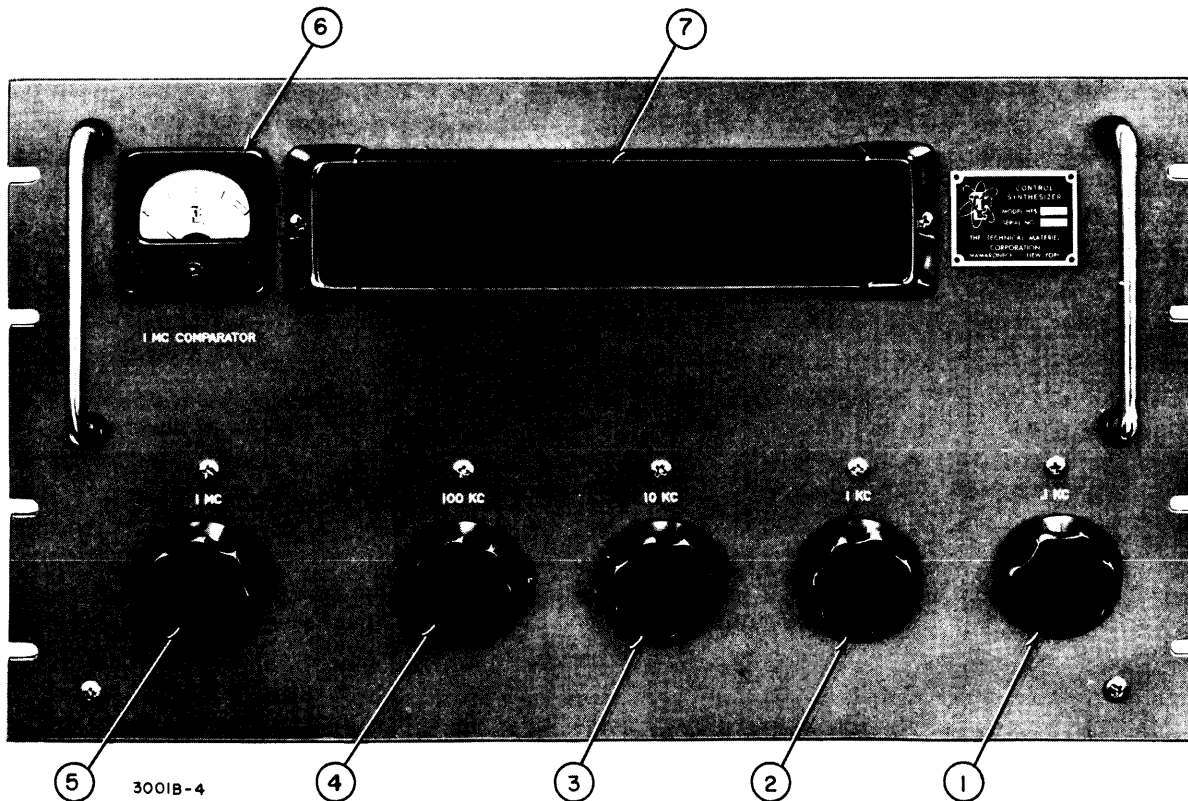


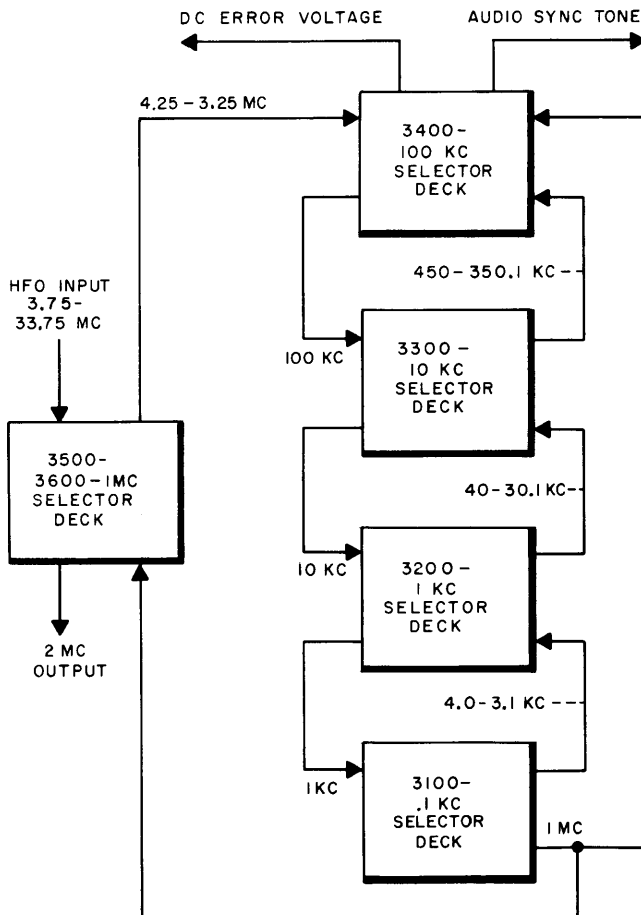
Figure 3-1. HFS-1 Front Panel Controls

635-17-1

SECTION 4 PRINCIPLES OF OPERATION

4-1. SIMPLIFIED BLOCK DIAGRAM ANALYSIS. (See figure 4-1.)

A 1-mc oscillator, which generates the basic reference signal for the synthesizer, is contained in the 3100 deck. This 1-mc standard is coupled to the 3400 deck where it is reduced to 100 kc; the 100-kc signal, in turn, is used to create synthesized frequencies in the 3400 deck. The same signal is also applied to the 3300 deck where it is reduced to 10-kc and used as a reference for synthesizer circuits in the 3300 deck. This signal is also applied to the 3100 deck where it is reduced to 100 cycles and subsequently used in the 3100 deck synthesizer circuits.



3001B-5

Figure 4-1. HFS-1, Simplified Block Diagram

In the 3100 deck, the 100-cycle signal is used in the synthesizer circuits to produce a signal between 4 and 3.1 kc, depending on the position of the .1 KC switch. This signal is applied to the 3200 deck where it is added to a synthesized 36 to 27-kc signal to produce a 40 to 30.1-kc output.

The 10-kc signal in the 3300 deck is used in the synthesizer circuits to produce a 410 to 320-kc signal, depending on the position of the 10 KC switch. This signal is added to the 40 to 30.1-kc signal to produce a 450 to 350.1-kc signal. In the 3400 deck, the 100-kc signal is used in the synthesizer circuits to produce a frequency in the range of 3.8 mc to 2.9 mc, depending on the position of the 100 KC switch. This signal is added to the 450 to 350.1-kc signal to produce a 4.25 to 3.2501-mc signal which is subsequently applied to a phase detector.

The same 1-mc signal which is generated in the 3100 deck is also coupled to the 3500-3600 deck where it is used in the synthesizer circuits and applied to a second harmonic generator. These circuits also employ a 48.5 - 77.5-mc oscillator, tuned in 30 one-megacycle steps. Another input to the synthesizer circuits arrives from the HFO circuits in the HFR-1 Continuous RF Tuner. Since the HFO is always operating 1.75 mc above the incoming signal, the HFO frequency input will range from 3.75 to 33.75 mcs.

The synthesizer circuits of the high frequency loop produce frequencies between 4.25 and 3.25 mc, tunable in 30 one-megacycle steps. This 4.25 to 3.25-mc frequency contains the error, if any, of the HFO circuit. It is delivered to the phase detector circuit of the 3400 deck. The phase detector compares the two normally identical frequencies and develops a correction voltage, the amplitude and polarity of which is determined by the error of the HFO. The correction voltage is used to correct the HFO error. The phase detector circuit also produces an audio sync tone for tuning and alignment purposes. The tone frequency is proportional to the error voltage; no tone is produced when the error is zero.

The switching is coded so that the received signal frequency is displayed on the synthesizer front panel. The actual frequency output of each synthesizer deck is indicated in table 4-1. The indicator position refers to the nixie lamp lit at each selector deck.

TABLE 4-1. PRODUCT CHART OF BASIC SYNTHESIZER

INDICATOR POSITION	DECK 3400	DECK 3300	DECK 3200	DECK 3100
0	3.8 mc	410 kc	36 kc	4.0 kc
1	3.7 mc	400 kc	35 kc	3.9 kc
2	3.6 mc	390 kc	34 kc	3.8 kc
3	3.5 mc	380 kc	33 kc	3.7 kc
4	3.4 mc	370 kc	32 kc	3.6 kc
5	3.3 mc	360 kc	31 kc	3.5 kc
6	3.2 mc	350 kc	30 kc	3.4 kc
7	3.1 mc	340 kc	29 kc	3.3 kc
8	3.0 mc	330 kc	28 kc	3.2 kc
9	2.9 mc	320 kc	27 kc	3.1 kc

The following examples should clarify the operation of the unit.

EXAMPLE NO. 1

If the indicator readout pertaining to the basic synthesizer reads 0 0 0 0, the output of the 3400 deck to the phase detector would be $3.8 \pm .41 + .036 + .004 = 4.25$ mc.

The output of the 3300 deck to the 3400 deck would be $.41 + .036 + .004 = .45$ mc.

The output of the 3200 deck to the 3300 deck would be $.036 + .004 = .04$ mc.

The output of the 3100 deck would be .004 mc.

EXAMPLE NO. 2

To obtain .44 mc to the 3400 deck from the 3300 deck:

- Set the 3100 deck to position 0 .004
- Set the 3200 deck to position 0 .036
- Set the 3300 deck to position 1 $\frac{.400}{.44}$ mc

EXAMPLE NO. 3

To obtain .36 mc to the 3400 deck from the 3300 deck:

- Set the 3100 deck to position 0 .004
- Set the 3200 deck to position 0 .036
- Set the 3300 deck to position 9 $\frac{.320}{.360}$ mc

4-2. DETAILED BLOCK DIAGRAM ANALYSIS.

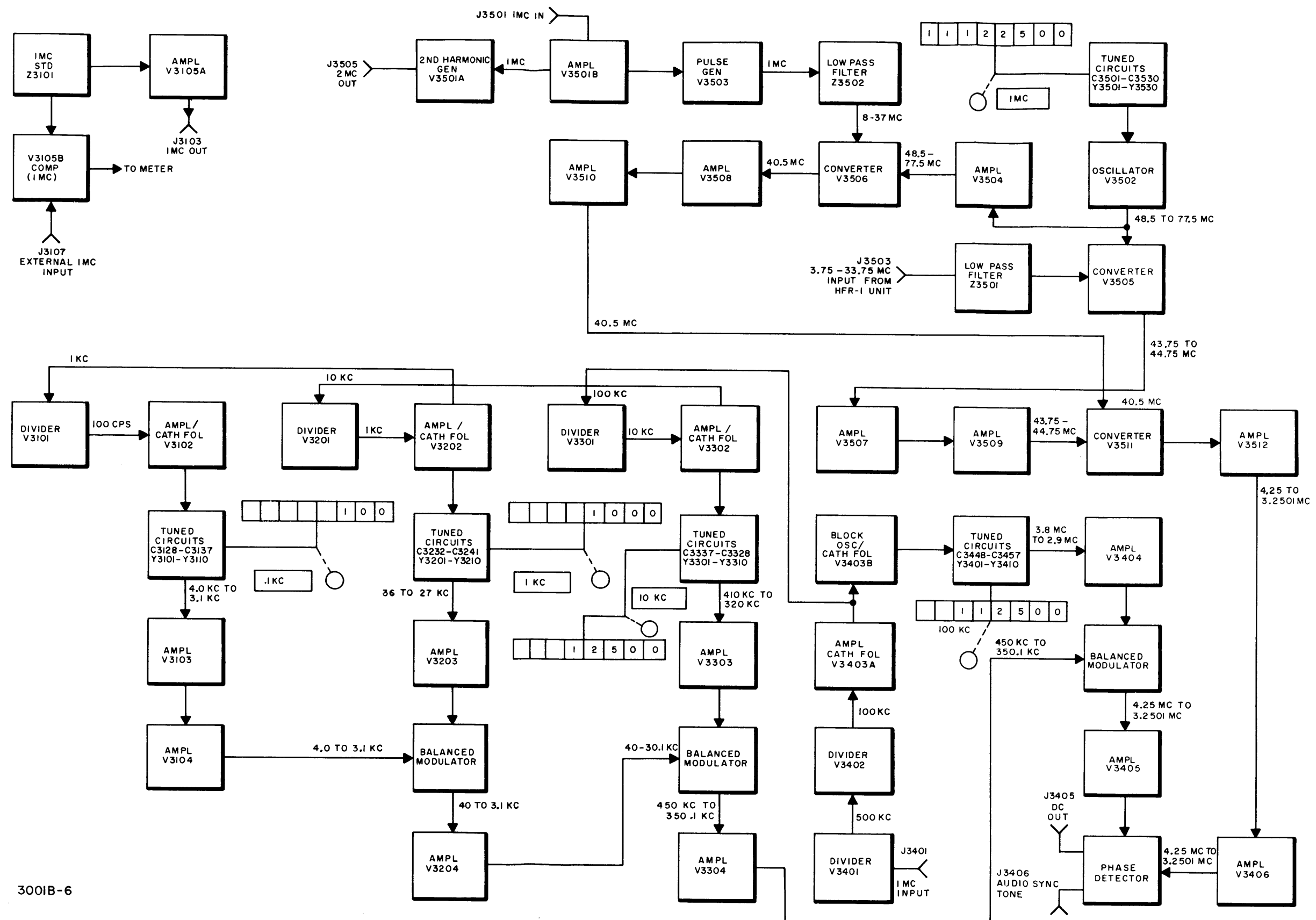
(See figure 4-2.)

a. 3100 DECK. The .1 kc selector deck (3100 deck) receives pulses at a frequency of 1 kc from the 3200 deck. The 3100 deck delivers an output in ten .1-kc steps from 4.0-kc to 3.1 kc to the 3200 deck. The actual output frequency is dependent on the setting of the .1 KC selector switch (S3101).

The 1-kc pulses from the 3200 deck are applied to V3101, a 10:1 divider circuit. The 100-cycle output is applied through cathode follower V3102 to a tuned circuit consisting of capacitors C3128 to C3137 and crystals Y3101 to Y3110. The output frequencies between 4.0 and 3.1 kc, dependent on the position of the .1 kc switch, are generated by this network. This tuned signal is amplified through V3103 and V3104 and applied to the balanced modulator in the 3200 deck.

Included in the 3100 deck is the 1-mc standard, which acts as a reference for the entire system. The output from Z3101 is applied to phase comparator V3105B and amplifier V3105A, where it is amplified and then coupled to J3103. An external 1-mc signal can be connected at J3107. Both the internal and external 1-mc signals are connected to the phase comparator which couples the signals to a phase comparator meter on the front panel.

b. 3200 DECK. The 1-kc selector deck receives 10-kc pulses from the 3300 deck and signals between 4 and 3.1 kc from the 3100 deck. The 10-kc pulses are applied to divider V3201 which produces a 1-kc output which is coupled to amplifier-cathode follower



300IB-6

Figure 4-2. HFS-1, Block Diagram

V3202 and divider V3101 in the 3100 deck. The harmonic-rich, 1-kc pulses at the cathode of V3202 are applied to tuned circuits consisting of capacitors C3232 to C3241 and crystals Y3201 to Y3210. Frequencies between 36 and 27 kc are generated by these tuned circuits; the selected frequency dependent on the position of the 1 KC control.

The 36 to 27-kc signal is amplified through V3203 and coupled to a balanced modulator network along with a 4.0 to 3.1-kc signal from amplifier V3104 in the 3100 deck. The balanced modulator circuit produces sum and difference frequencies; however, a tuned network passes only the sum frequencies. Thus the output of the balanced modulator consists of signals in a 40 to 30.1-kc frequency range. These signals are coupled to amplifier V3204.

c. 3300 DECK. The 3300 deck (10-kc selector deck) receives 100-kc pulses from the 3400 deck. These 100-kc pulses are applied to 10:1 divider V3301 which produce a 10-kc output. This 10-kc signal is then coupled through amplifier and cathode follower V3302 to a tuned network consisting of capacitors C3337 to C3328 and crystals Y3301 to Y3310. Frequencies between 410 and 320 kc are generated by this network; the output frequency is dependent on the position of the 10 KC selector switch. This signal is amplified in V3303 and applied to a balanced modulator. Signals between 40 and 30.1 KC are also coupled to this particular modulator which generates a 450 to 350.1-kc output. This signal is amplified in amplifier V3304.

d. 3400 DECK. In the 3400 deck (100-kc selector deck), a 1-mc signal is coupled through J3401 to divider V3401 which, in turn, generates a 500-kc signal. This 500-kc signal is then further divided to 100 kc by divider V3402. This signal is then coupled through amplifier-cathode follower V3403A to divider V3301 in the 3300 deck and to block oscillator V3403B, which generates harmonically-rich pulses. The 100-kc pulse output from V3403B is coupled to tuned filters consisting of capacitors C3448 to C3457 and crystals Y3401 to Y3410. These narrow band filters are tuned to the 29th through 38th harmonics of 100 kc. The output frequency from these circuits, dependent on the position of the 100 KC front panel, is between 2.9 and 3.8 mc.

These signals are amplified in V3404 and coupled to a balanced modulator along with a 450 to 350.1-kc signal from amplifier V3304 in the 3300 deck. The balanced modulator generates signals between 4.25 and 3.2501 mc. These signals are amplified

in V3405 and coupled to a phase detector. A 4.25 to 3.2501-mc signal is also applied to the phase detector through amplifier V3406. The phase detector compares the phases of these two normally identical frequencies. A dc correction voltage output, the amplitude and polarity of which is determined by the error between the two signals, is generated by the phase detector. This dc voltage, coupled to J3405, is used to correct the HFO frequency by changing the bias on a VARICAP in that circuit. The phase detector also generates an audio sync tone, the frequency of which is proportional to the error between the two signals. This audio sync tone can be monitored at J3406.

e. 3500 - 3600 DECK. The 3500 - 3600 deck, also known as the high frequency loop or 1-mc selector deck, receives: (1) A 1-mc signal from the frequency standard circuits; and, (2) A sample of the HFO circuit in the HFR-1 Continuous RF Tuner in the range 3.75 to 33.75-mc. The 3500 - 3600 deck delivers: (1) A 2-mc signal for use in the second converter circuit of the Model HFI-1; and, (2) A frequency between 4.25 and 3.25-mc (the selected frequency is dependent on the position of the 1-mc switch).

The 1-mc input is coupled through J3501 and amplified in V3501B. The output from V3501B is applied to V3501A and V3503. V3501A, a second harmonic generator, provides a 2-mc output at J3505. V3503, a pulse generator, shapes the 1-mc signal to provide a signal rich in harmonics. These 1-mc pulses are applied to low pass filter Z3502 which passes signals between the 8th and 37th harmonics of the 1-mc signal. These signals are applied to converter V3506.

A 48.5 to 77.5-mc signal is generated by oscillator V3502 and applied to converter V3505 and amplifier V3504. V3506 always generates a 40.5-mc signal, regardless of the operation frequency. This 40.5-mc output is amplified through cascade amplifiers V3508 and V3510 and coupled to converter V3511.

The output from oscillator V3502 is also applied to converter V3505. The second input to this converter, a signal between 3.75 and 33.75 MC, comes from the HFO circuits in the HFR-1. This input is coupled through low pass filter Z3401 to V3501. The converter generates a 43.75 to 44.75-mc output. The local oscillator frequency is always 1.75 MC above the received signal. Note the relationships of the various signals in table 4-2 below. All frequencies in the following table are in megacycles.

TABLE 4-2. FREQUENCY RELATIONSHIPS

RECEIVER FREQUENCIES	LOCAL OSCILLATOR FREQUENCIES	OSCILLATOR V3502 FREQUENCIES	CONVERTER V3505 OUTPUT
2	3.75	48.5	44.75
3	4.75	49.5	44.75
4	4.75	50.5	44.75
4.2	5.95	50.5	44.55
4.8	6.55	50.5	43.95
4.9	6.65	50.5	43.85
4.95	6.70	50.5	43.70
4.99	6.74	50.5	43.76

The 43.75 to 44.75-mc output from V3505 is amplified through cascade amplifiers V3507 and V3509 and coupled to converter V3511. The second input to V3511 (a 40.5 mc signal) is coupled from amplifier V3510. The output from V3511 is a signal between 4.25 and 3.2501 mc. This signal is coupled through amplifier V3406 to the phase comparator in the 3400 deck.

4-3. DETAILED CIRCUIT ANALYSIS OF 3100 DECK.
(See figure 4-5.)

a. DIVIDER 3101. The 1-kc input signal from the 3200 deck is coupled through J3101 to phantastron divider V3101. Frequency division is accomplished in the HFS-1 unit by phantastrons such as that found in the 3100 deck. Figure 4-3 shows a simplified schematic of a typical cathode-coupled phantastron along with some significant waveforms. To gain an understanding of how a typical phantastron works, refer to this illustration along with the following explanation.

When the negative portion of pulse 1 reaches the control grid of V1, the grid's potential is dropped. A trigger impulse of 30 volts is needed to drive the grid downward. The initial drop in grid and plate voltage for this cathode-coupled circuit must be large enough for the cathode to fall a sufficient amount to raise the relative level of the suppressor grid into the region where plate current can flow. (Note that the suppressor is returned to a more negative point than the plate, so that initially the plate current in V1 is cut-off.) As in a cathode follower, cathode voltage follows that of the control grid voltage.

The first negative pulse now cuts off the cathode's electrons to the suppressor and switches them to the plate, since the suppressor voltage is higher than that of the cathode. Consequently, the plate voltage drops as shown in the illustration. It should be noted that the first negative pulse charges capacitor C so that the "left hand" plate is negative

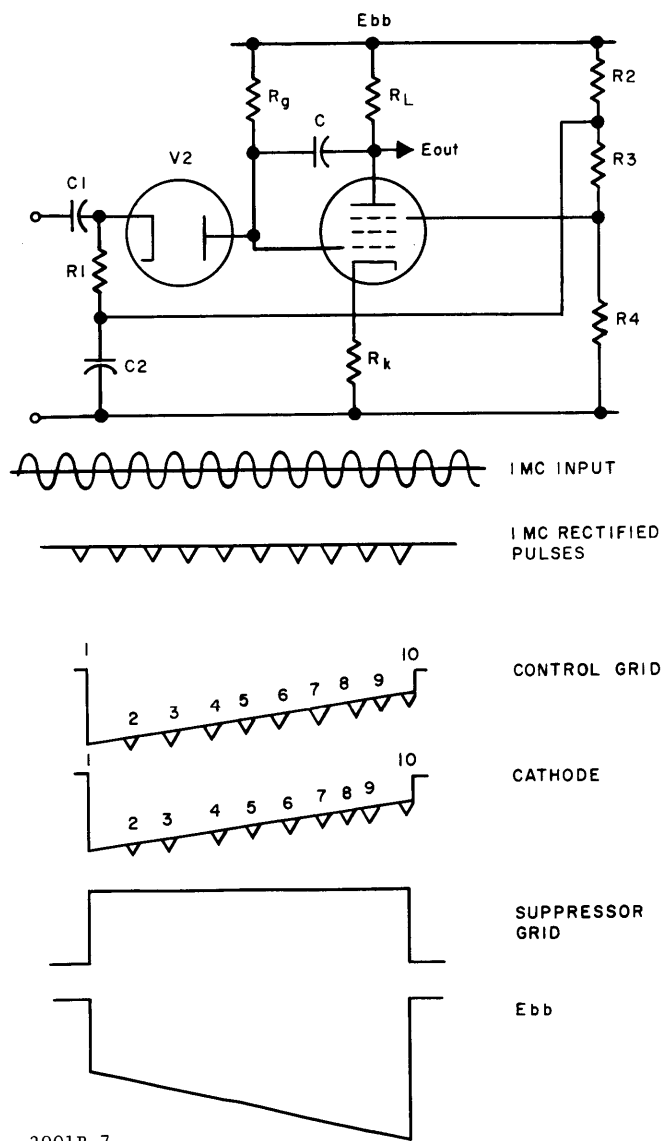


Figure 4-3. Simplified Schematic of Typical Phantastron and Accompanying Waveforms

whereas the "right-hand" plate is positive. It should also be noted that the potential at the junction of R₂/R₃ increases to the point where V₂ responds feebly to incoming pulses 2, 3, through 9. Furthermore, the potential at the junction of R₁ and C is lower than that of E_{bb}. As a result, voltage E_{bb} charges capacitor C via R_g and the potential on VI's control grid rises, as shown in the illustration. Naturally the potential on VI's cathode follows.

At the tenth negative pulse, the relative potentials at VI's cathode and suppressor grids are such that the electrons from the cathode are switched from the plate to the suppressor. This completes the time delay switching action.

It should be noted that the potential at the junction of R_L and C is variable where as that at the "top end" of R_g is fixed. If the potential at the junction of R_L and C was constant, the same as the potential at the "top end" of R_g, an exponential voltage would have been applied to the control grid of V₁. The contrary being the case, the voltage applied to the control grid of V₁ is linear, as shown in the illustration. This characteristic makes the phantastron circuit ideal for frequency-dividing purposes. In HFS's phantastron circuits, the one-tenth frequency output is taken from the screen grid, instead of at the plate, as shown in the illustration.

b. AMPLIFIERS V3102 - V3104. The 100-cycle output at pin 6 of V3101 is applied to the grid of amplifier-cathode follower V3102 through a differentiator network consisting of R3110 and C3104. With a time constant of 500 microseconds, the dif-

ferentiator generates positive and negative spikes occurring at a frequency of 100 cps. This harmonic rich output is applied to a filter network consisting of crystals Y3101 through Y3110 and trimmers C3128 through C3137. Operating between 3.1 and 4 kc, the output frequency from the filter network is determined by the position of the front panel .1 KC control (S3101E and S3101D).

The selected frequency from the wiper of S3101D is applied to amplifier V3103. The amplified output from V3103 is coupled to the grid (pin 1) of amplifier V3104. The plate circuit of V3104 is tuned by shunting the primary of T3101 with various capacitances selected by S3101B. The 3.1 to 4-kc output from V3104 is coupled to J3102 where it is used in the balanced modulator in the 3200 deck.

V3104 employs an AGC network to insure a reasonably constant output amplitude regardless of the frequency selected. When the signal amplitude at C3119 exceeds 25 volts, the capacitor charges on the positive excursions through CR3102 and discharges through CR3103 on the negative excursions, into C3117. The pulsating AGC voltage, filtered by R3125 and C3116, is coupled to the grid of the tube.

c. 1-MC FREQUENCY STANDARD (See figure 4-4.)

The 3100 deck also houses the 1-mc standard and comparator circuits. A James Knight sealed 1-mc Standard (Z3101), an octal plug-in unit containing the crystal standard, a transistor oscillator, oven circuits, and trimmer adjustments, is used as the basic reference source. This standard supplied a 1-mc signal accurate to one part in 10⁸ per day.

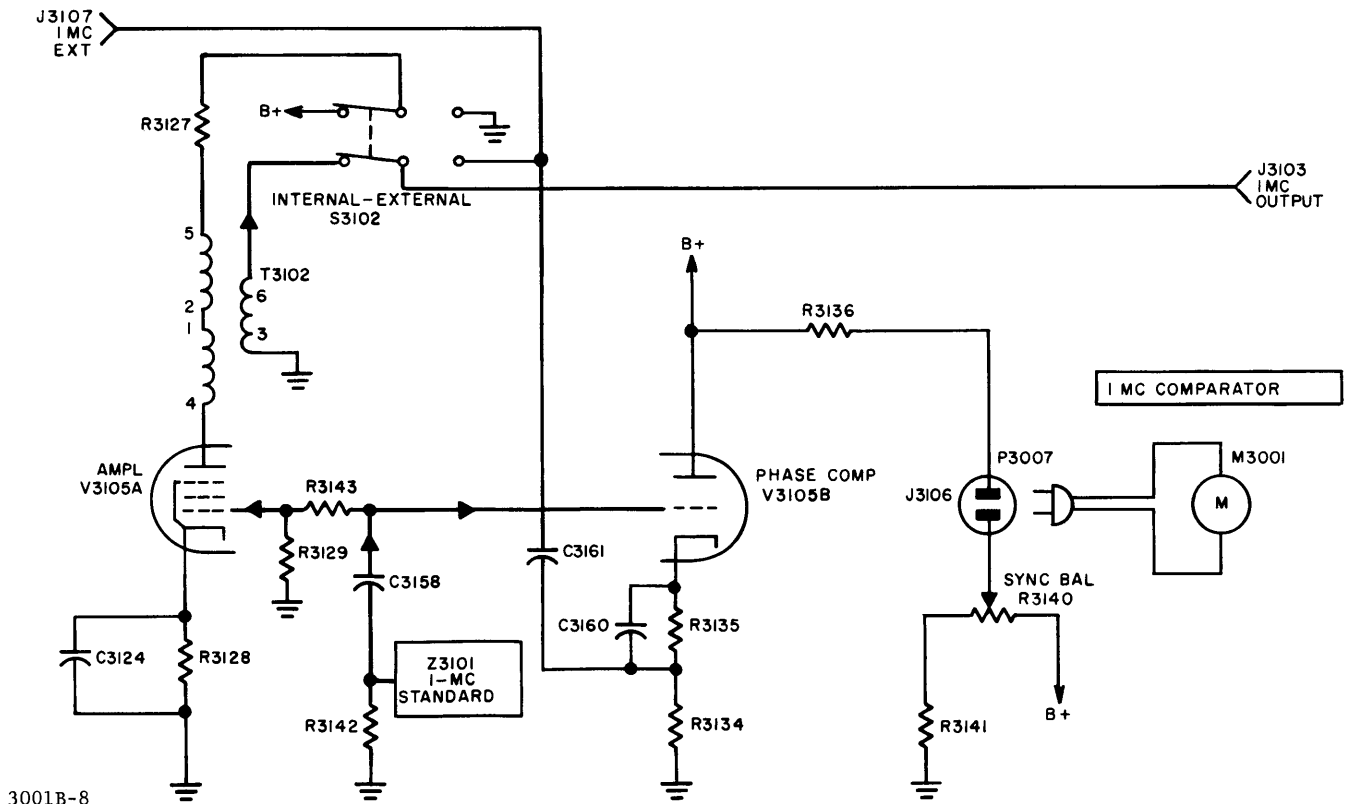


Figure 4-4. 1-Mc Frequency Standard Schematic Diagram (Part of 3100 Deck)

Amplifier V3105A amplifies the 1-mc signal and couples it through T3102 to Internal-External switch S3102. With S3102 in the Internal position, B+ is applied to V3105A and the output is coupled to 1-mc output jack J3103. With S3102 in the External position, B+ is removed from V3105A and a 1-mc external signal, connected to J3107, can be used as a standard.

The phase comparator circuit (V3105B) receives the internal signal at the control grid (pin 2) and the external signal at the cathode. With no signal inputs, the voltage at the plate (pin 3) rests at some value of static plate voltage. Sync balance control R3140 is adjusted to give a zero center reading on the 1 MC COMPARATOR meter. With two normally identical 1-mc inputs, the plate voltage at pin 3 will swing higher and lower, as the two inputs swing in and out of phase. The rate of swing is a measure of the error in the internal standard. If, for example, one complete swing occurs in five seconds, the error is 1/5 cycle.

4-4. DETAILED CIRCUIT ANALYSIS OF 3200 DECK. (See figure 4-7.)

a. DIVIDER 3201, CATHODE FOLLOWER V3202 and AMPLIFIER V3203. Triggers at a frequency of 10 kc arrive at J3201 from the 3300 deck. These triggers which may be monitored at TP3201 are applied to V3201, a 10:1 phantastron divider circuit. A divider adjust control (R3203) in the grid circuit of V3201 adjusts the output frequency to 1 kc. For a thorough explanation of the operation of a phantastron circuit, see paragraph 4-3a. The 1-kc output at pin 6 is applied through a differentiator circuit to amplifier-cathode follower circuit V3202. This differentiator, consisting of C3204 and R3210, generates positive and negative spikes. The plate output at V3202, consisting of negative triggers, is coupled to 1-kc output jack J3202 for use in the 3100 deck. The cathode output, consisting of positive triggers, is applied to a crystal filter operating between 27 and 36 kc. This filter network is composed of crystals Y3201 through Y3210 and capacitors C3232 through C3241. The operating frequency is determined by switches S3201F and S3201E. The selected frequency at the wiper of S3201E is applied to amplifier V3203. The plate circuit of the stage is tuned by the primary of T3201 and selected values of capacitance, connected in shunt by S3201D.

b. BALANCED MODULATOR CR3202 AND AMPLIFIER V3204. The plate output of V3205 is coupled through T3201 to a balanced modulator circuit consisting of plug-in diode bank CR3202 and associated components. The second input to the balanced modulator is coupled from J3203 to the wiper of balance adjust control R3219. This signal, the output of the 3100 deck, is at a frequency between 3.1 and 4 kc, as selected by S3101 on the 3100 deck.

The rectifying units (CR3202) used in the balanced modulator operate as carrier-controlled switches. The two signals (27 to 36 kc and 3.1 to 4 kc) are combined in such a manner that the output contains the original 3.1 to 4 kc signal and the upper and

lower sidebands at 30.1 to 40 kc and 23.9 to 32 kc respectively. The original carrier frequency is not in the output. Figure 4-6 shows a balanced-bridge modulator. The carrier signal (27 to 30 kc) is coupled to T3201 while the "audio" signal (3.1 to 4 kc) is coupled to balance adjust control R3219. The series and shunt-connected diodes comprising CR3202 alternately "open" and "close," depending on the instantaneous polarity of the carrier source. This causes the output polarities to reverse at a 30.1 to 40-kc rate with respect to the 3.1 to 4-kc input polarities.

The multiple-frequency output from the balanced modulator is coupled to the grid circuit of V3204. The grid circuit of V3204 is tuned between 30.1 and 40 kc (the upper sideband) by T3202 and capacitances selected by S3201C. Its plate circuit is tuned by the primary of T3203 and selected capacitances inserted by S3201B. The output from V3204 is coupled through T3203 and to 30.1 to 40-kc output jack J3204.

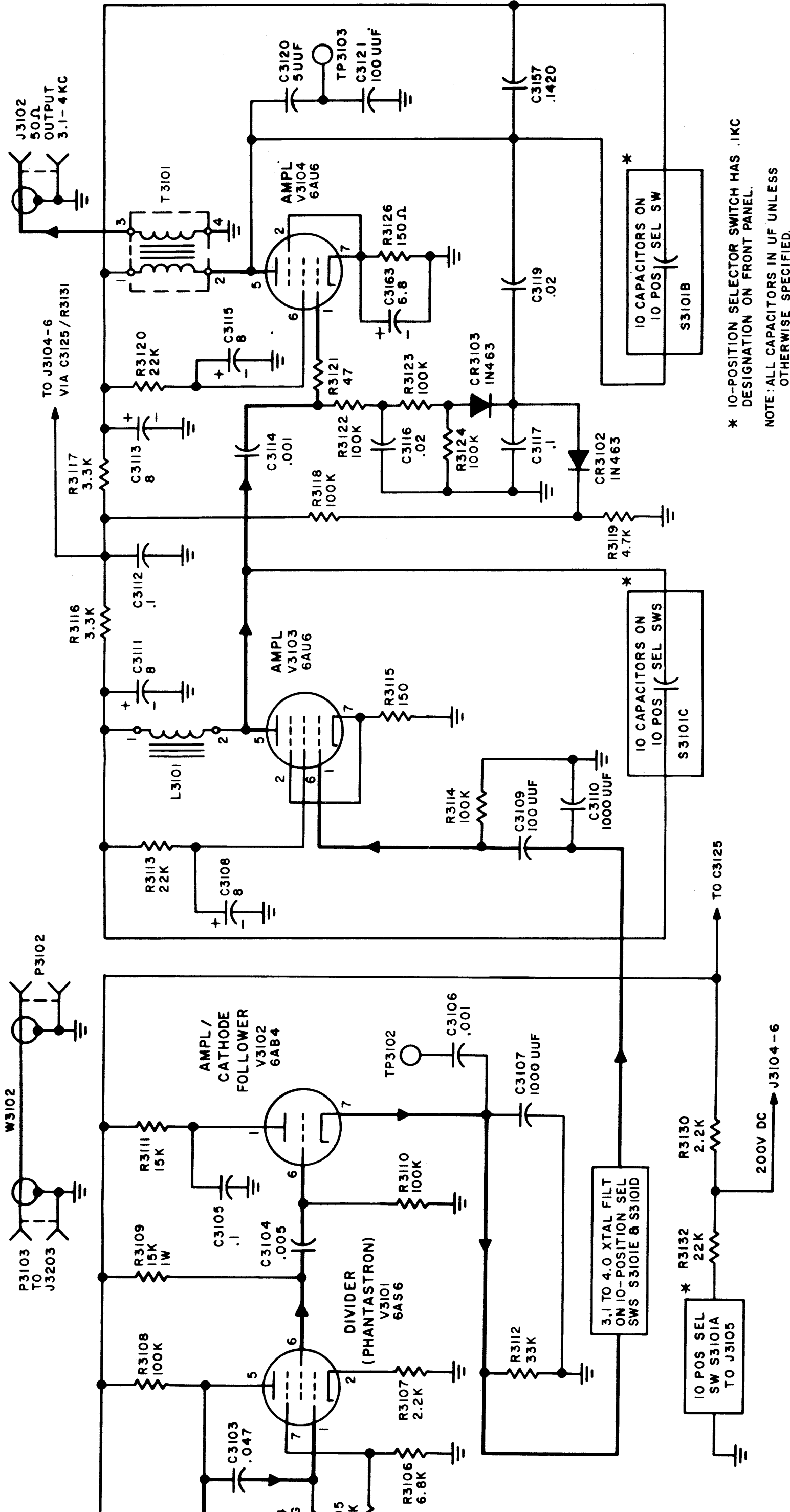
Associated with V3204 is an AGC network similar to that encountered in the 3100 deck. The signal at the plate of V3204 is coupled to an AGC network. CR3204 is the delay diode, back-biased by voltage divider R3220 and R3221. CR3203 is the AGC diode and C3218 the AGC capacitor, which discharges through R3231.

4-5. DETAILED CIRCUIT ANALYSIS OF 3300 DECK. (See figure 4-8.)

a. DIVIDER V3301, CATHODE FOLLOWER V3302, AMPLIFIER V3303. Triggers at a frequency of 100-kc are coupled from J3301 and applied to V3301, a 10:1 phantastron divider. A divider adjust control (R3303) in the grid circuit of V3301 adjusts the output frequency to 10 kc. For a thorough explanation of the phantastron circuit, see paragraph 4-3a in this manual.

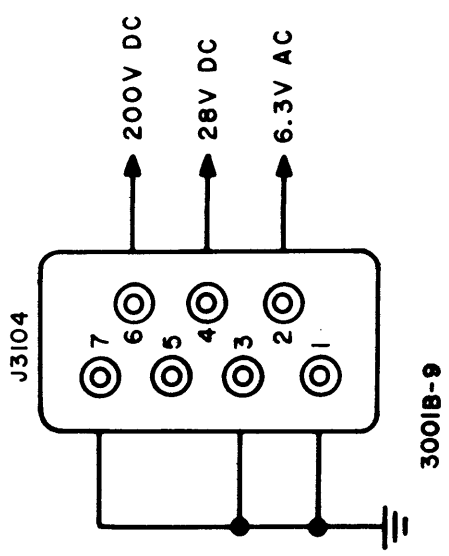
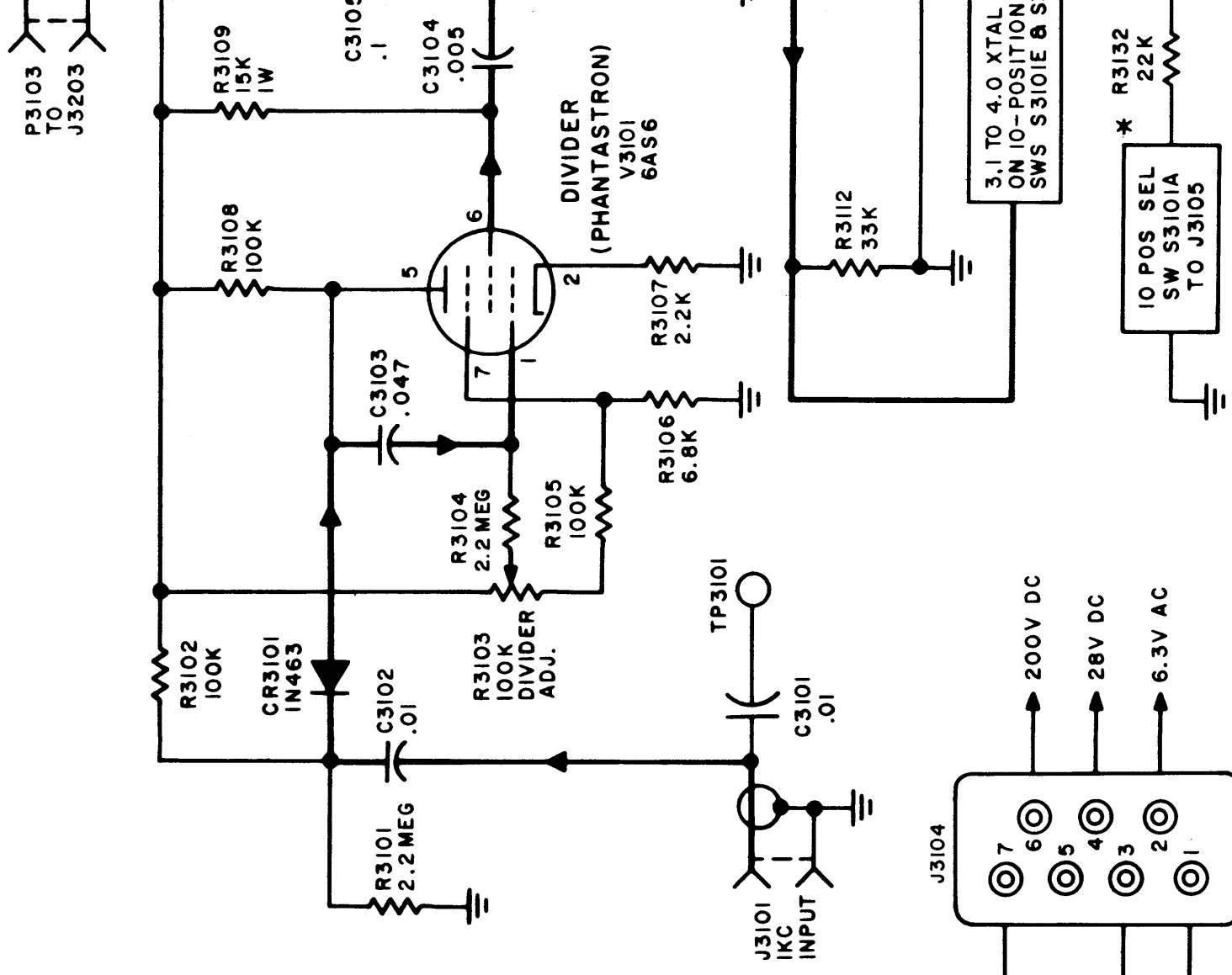
The 10-kc output at pin 6 is applied through a differentiator circuit to cathode follower V3302. The differentiator, consisting of C3304 and R3310, generates a spike output. The plate output of V3302, consisting of negative triggers, is coupled to 10-kc output jack J3302 for use in the 3200 deck. The cathode output, consisting of positive peaks, is applied to a crystal filter operating between 320 and 410 kc. Tunable in 10-kc steps, the crystal filter is composed of crystals Y3301 to Y3310 and capacitors C3328 to C3337. The operating frequency is determined by switch sections S3301E and S3301F. The selected frequency at the wiper of S3301E is applied to amplifier V3303. The plate circuit of this stage is tuned by the primary of T3301 and selected values of capacitance, connected in shunt by S3301D.

b. BALANCED MODULATOR AND AMPLIFIER V3304. The plate output of V3303 is coupled through T3301 to a balanced modulator circuit consisting of plug-in diode unit CR3302 and associated components. The second input to the balanced modulator circuit is applied from J3303 to the wiper of balanced adjust potentiometer R3330. This signal, the output of the

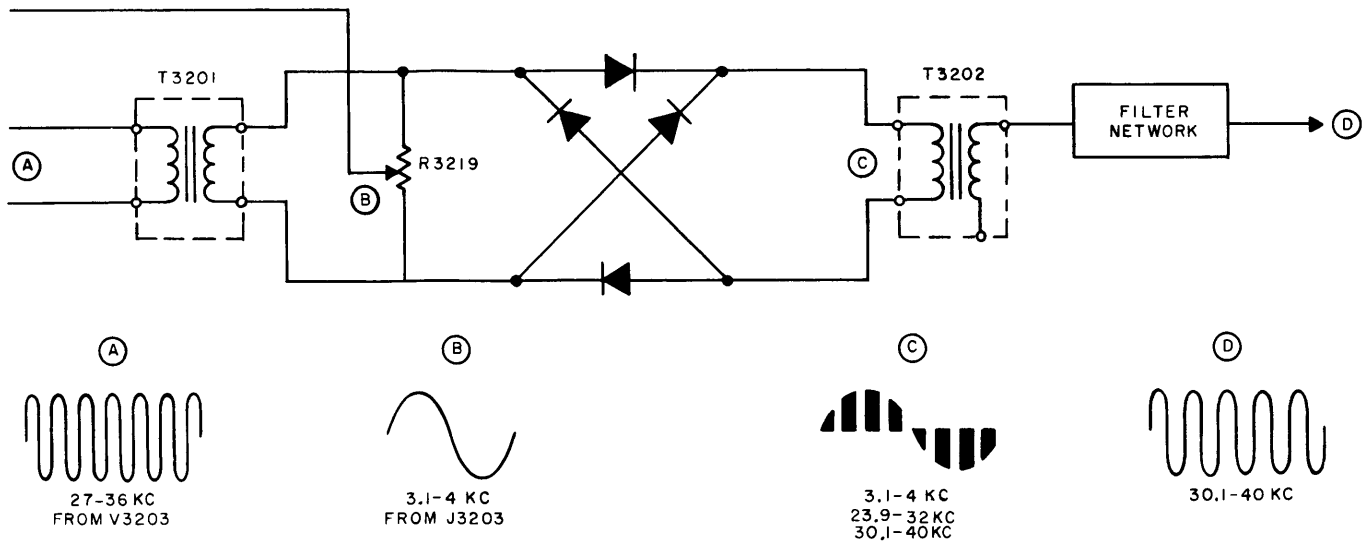


* 10-POSITION SELECTOR SWITCH HAS .1KC DESIGNATION ON FRONT PANEL.
 NOTE: ALL CAPACITORS IN UF UNLESS OTHERWISE SPECIFIED.

Figure 4-5. 3100 Deck, Simplified Schematic Diagram



109653001B



30C1B-10

Figure 4-6. Balanced Modulator and Waveforms

3100 deck, is a frequency between 30.1 and 40 kc, as selected by S3101 on the 3100 deck and S3201 on the 3200 deck. The balanced modulator produces sum and difference frequencies, but only the sum frequencies are passed. The significant output, then, is a signal between 350.1 and 450 kc. The output frequency, which depends on the setting of S3101, S3201, and S3301, is coupled through T3302 to V3304, the output amplifier. This range of frequencies represents an overall bandwidth of 100 kc. The grid circuit of V3304 is tuned by the secondary of T3302 and selected capacitances inserted by S3301C. The plate circuit of V3304 is tuned by the primary of T3303 and various capacitances inserted by S3301B.

Associated with V3304 is an AGC network similar to that encountered in the 3200 deck. The signal at the plate of V3304 is coupled back to the AGC network through C3323. CR3304 is the delay diode, back biased by voltage divider network R3332 and R3322. CR3303 is the AGC diode and C3319 the AGC capacitor, which is allowed to discharge through R3320 as necessary.

4-6. DETAILED CIRCUIT ANALYSIS OF 3400 DECK. (See figure 4-11.)

a. MULTIVIBRATOR V3401. The 1-mc reference signal from the standard circuit in the 3100 deck (see paragraph 4-3d, this manual) is coupled through 1-mc input jack J3401 to step-up transformer T3401 and 1-mc output jack J3402. The 1-mc signal at J3402 is applied to the 3500-3600 deck. The 1-mc signal at the secondary of J3401 is coupled through diodes CR3401 and CR3402 to the grids of multivibrator V3401. See figure 4-9.

V3401, basically an Eccles-Jordan trigger circuit, is a driven oscillator whose operation and frequency is controlled by the 1-mc trigger input. This trigger input is rectified through CR3401 and CR3402 and the resulting negative pulses are coupled to the grids

(pins 2, 7) of V3401. The circuit possesses two conditions of stable equilibrium. One condition is when V3401A is conducting and V3401B is cut-off; the other when V3401A is cut-off and V3401B is conducting. The sudden reversal of this flip-flop circuit is triggered by the 1-mc negative trigger inputs.

Initially, due to inherent unbalance in the tube, one portion of the tube will conduct while the other is cut-off. Therefore, only the conducting tube will produce an output. When the negative trigger acts on the conducting tube, it causes a sudden decrease in plate current and a corresponding rise in plate voltage. This voltage rise is coupled to the tube in cut-off. Therefore, the tube which was conducting is now cut-off and the tube in cut-off begins to conduct. This reversing from one state of equilibrium to another results in a 500-kc square wave output.

b. DIVIDER V3402 AND CATHODE FOLLOWER V3403A. The 500-kc squarewave is applied through C3406 through C3408 and CR3403 to 5:1 phantastron divider circuit V3402. The cathode of CR3403 is back-biased by the positive excursions of the square-wave input while the negative excursions trigger the phantastron. Divider adjust control R3411 is set for an output frequency of 100-kc from pin 6 of V3402. This 100-kc signal, differentiated by C3409 and R3418, is applied to cathode follower V3403A. The plate output of V3403A, consisting of positive triggers at 100-kc, is coupled to 100-kc output jack J3403. This 100-kc signal is used in the 3300 deck. The cathode output of V3403A, consisting of positive triggers at 100-kc, is applied to V3403B, a blocking oscillator.

c. BLOCKING OSCILLATOR V3403B AND AMPLIFIER V3404. Blocking oscillator V3403B is a free-running blocking oscillator which can be synchronized by the 100-kc output from amplifier V3403A. The natural frequency of the blocking oscillator is lower than the actual triggered frequency.

As indicated in figure 4-10, V3403B consists of a triode with transformer T3402 to provide coupling between plate and grid circuits. This transformer develops a positive voltage at the plate of the tube when an increasing current flows in the primary; a negative voltage is developed with a decreasing primary current. The dots at each winding indicate similar polarities. The transformer provides regenerative feedback between the plate and grid circuits, that is, an increase in plate current causes the grid to become more positive. A positive increase in grid voltage further increases the plate current. In this way a cumulative action takes place. Once the current starts increasing, it continues until plate-current saturation is reached.

T3402, with its distributed capacitance across its windings, acts as a resonant circuit. The high voltage developed across the secondary charges up this shunt capacitance. When this voltage decreases, the circuit begins to oscillate. The grid then swings from a positive voltage to a highly negative voltage.

Capacitor C3413 charges up to the positive grid voltage during the positive half-cycle. The charge path is through the low grid-to-cathode resistance of the tube. When the grid voltage swings negative, the full negative voltage is applied to the grid because the charge of the capacitor cannot charge instantaneously. This drives the tube beyond cut-off. Since the negative voltage makes the grid-to-cathode resistance very high, C3413 discharges through R3426.

The tube remains in the cut-off condition for a period of time that depends on the R3426-C3413 time constant. As the capacitor discharges through the resistor, the grid voltage increases until, after a period of time, the cut-off value is reached. At this time the tube starts to conduct. The increase in plate current causes an increase in grid voltage. This starts the cycle over again.

In the paragraphs above, it is assumed that V3403B is completely free-running and not synchronized. However, during normal operation, the blocking oscillator is synchronized to a 100-kc reference signal. As mentioned before, in a free-running blocking oscillator the grid is driven far beyond cut-off by the action of the grid-transformer winding and is maintained at a negative voltage by the charge in C3413. As C3413 discharges, the grid voltage increases until cut-off is reached.

If, however, a positive pulse is applied to the grid circuit before the grid reached cut-off, and is of sufficient magnitude to drive the grid above cut-off, the tube starts conducting at an earlier timer. The output, therefore, can be synchronized to the 100-kc pulse series; the output synchronized to each sync pulse that changes the tube from a cut-off to conducting state.

The output, consisting of a series of one-microsecond pulses with a time between pulses of ten microseconds, is taken from the cathode and applied to one of ten crystals operating between 2.9 and 3.8 mc. The crystals respond to the 29th through 38th

harmonics of 100 kc. S3401G and S3401F select the operating frequency which is turnable in 100-kc steps. The output at the wiper of S3401F is applied to amplifier V3404. The plate circuit of V3404 is tuned by the primary of T3403 and selected capacitances inserted by S3401E. The output of V3404 is coupled through T3403 to a balanced modulator.

d. BALANCED MODULATOR AND AMPLIFIER V3405. The second input to the balanced modulator circuit arrives at the wiper of balance adjust control R3432 from J3404. The input, a signal between 350.1 and 450 kc, comes from the 3300 deck. The exact frequency depends on the settings of S3101, S3201, and S3301. The balanced modulator produces sum and difference frequencies but only sum frequencies are passed. The signal outputs, then, are signals between 3.2501 and 4.25 mc, and are tunable in 100-cycle steps.

The balanced modulator output is applied through the secondary of T3404 to V3405, the basic synthesizer output tube. The grid input is tuned by the secondary of T3404 and selected capacitances inserted into the circuit by S3401D. The plate output is tuned by the primary of T3405 and selected capacitances inserted by S3401C.

Associated with V3405 is an AGC loop similar to those encountered in other decks. The signal at the plate of V3405 is coupled to the loop by C3432. CR3413 is the delay diode, back-biased by voltage divider R3437 and R3438. CR3412 is the AGC diode; R3436 and C3428 form a filter storage network. R3435 provides a path for C3428 to discharge. The AGC voltage is applied to the grid of V3405 through T3404. The output from V3405 is applied to a phase detector circuit through T3405.

e. AMPLIFIER V3406 AND PHASE DETECTOR NETWORK. The 3.25 to 4.25-mc output of the 3500-3600 deck is coupled through J3407 and T3406 to the grid of amplifier V3406. The plate circuit of this amplifier uses a single inductor (L3401) and trimmer capacitances selected by S3401B. The plate output from V3406 is applied jointly to a basic phase detector, comprised of CR3409 and CR3410, and to a tandem phase detector, comprised of CR3408 and CR3411.

The basic phase detector compares the phase of the two input signals which are at a frequency between 3.25 and 4.25 mc. The signal from the basic synthesizer is locked to the 1-mc reference standard. The frequency from the high frequency loop contains the error of the HFO circuit; this is the signal to be corrected. The correction voltage is developed across the wiper of balance adjust control R3444. The amplitude and polarity of the correction voltage depends on the direction and amount of the phase error. The correction voltage is applied through low pass filter R3445, C3438, and C3437 to J3405. From this point it is delivered to the VARICAP in the HFO circuits in the HFR-1 Continuous RF Tuner. It should be noted that, for zero correction voltage from the basic phase detector, the two input signals are 90 degrees out of phase.

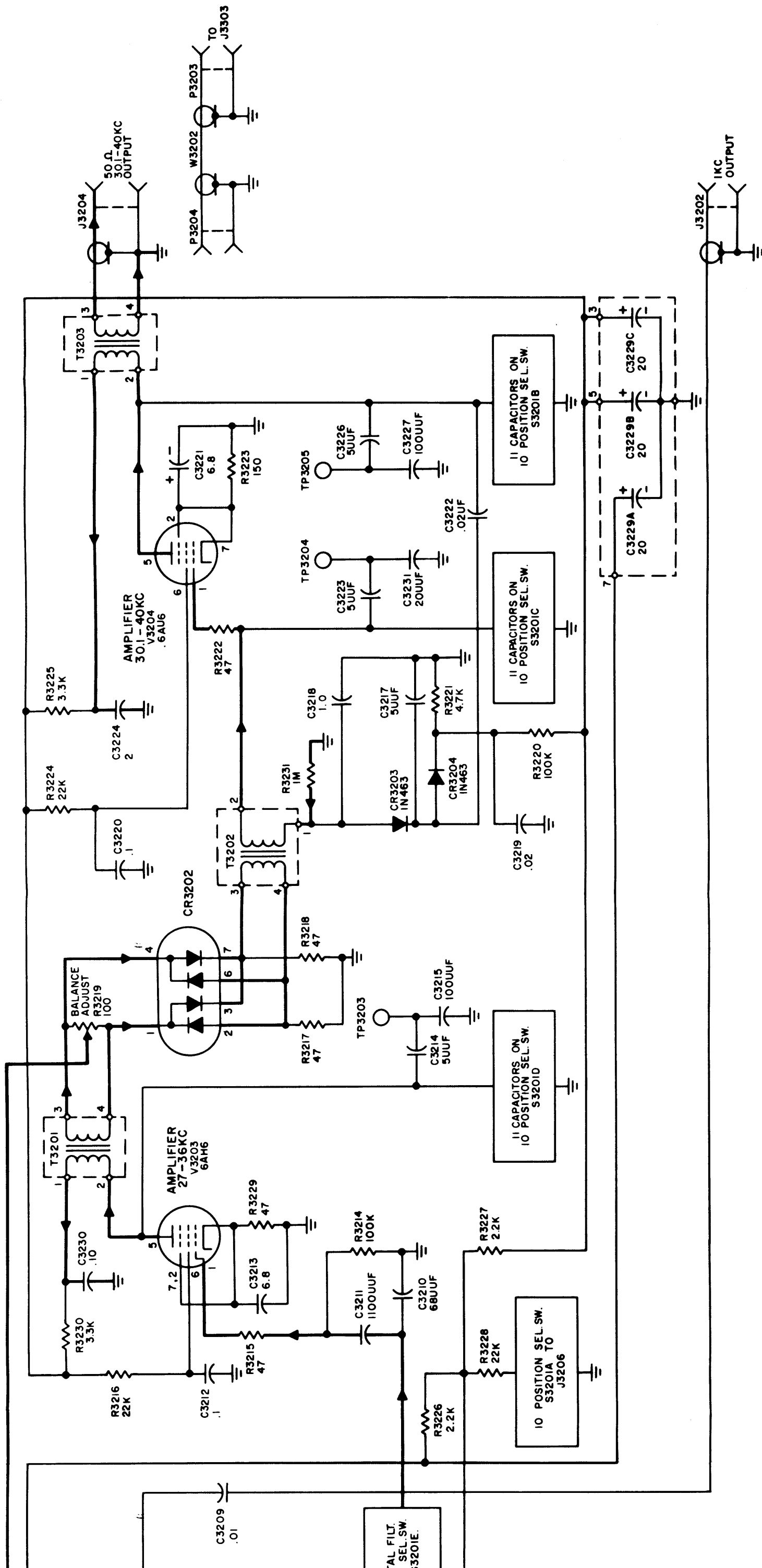
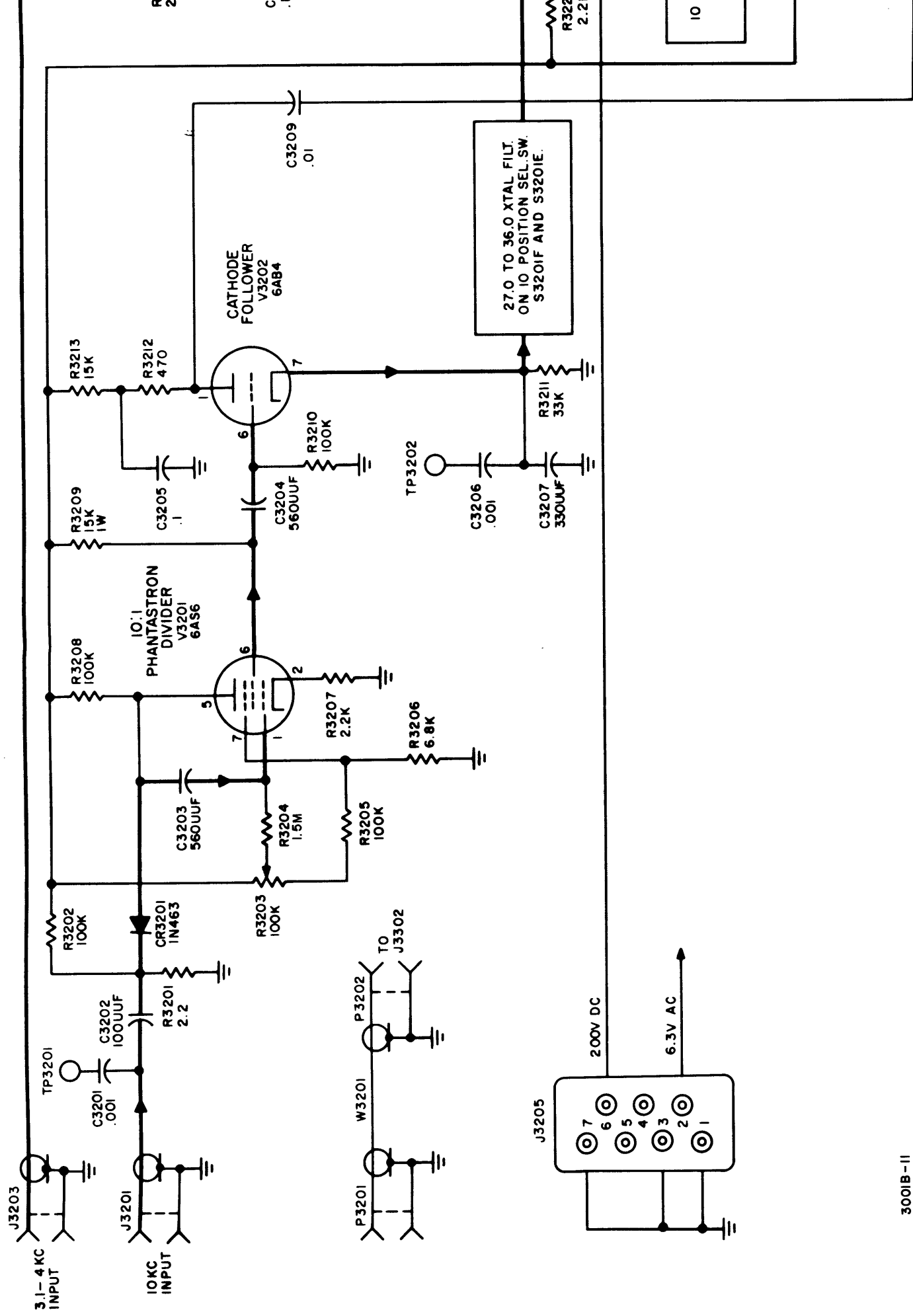


Figure 4-7. 3200 Deck, Simplified Schematic Diagram



3001B-11

109653001B

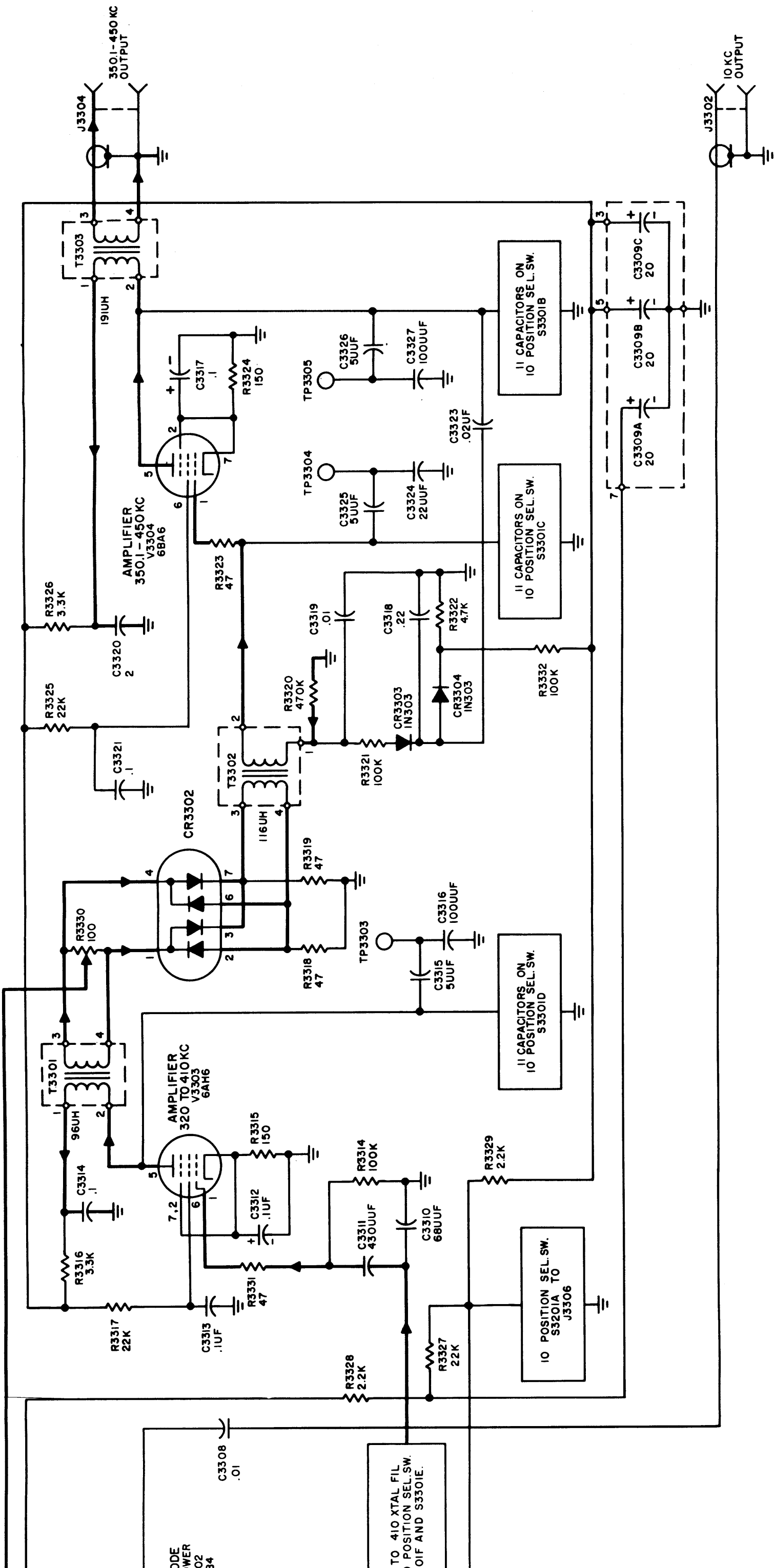
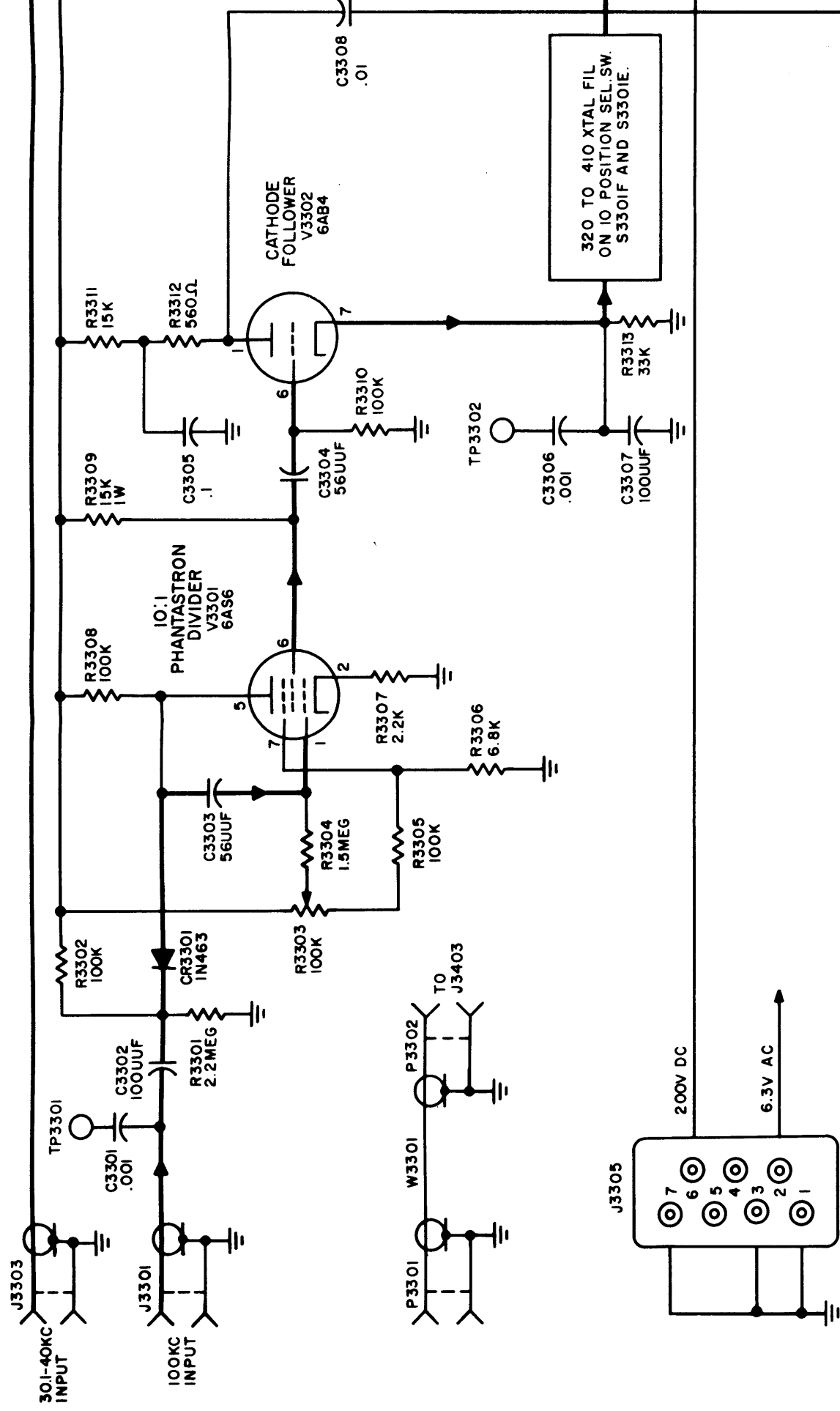


Figure 4-8. 3300 Deck, Simplified Schematic Diagram

4-15/4-16



3001B-12

109653001B

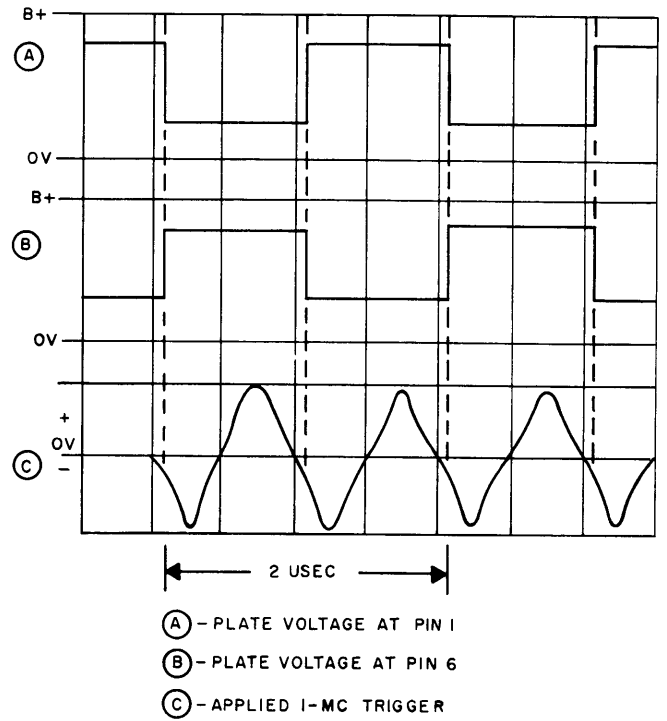
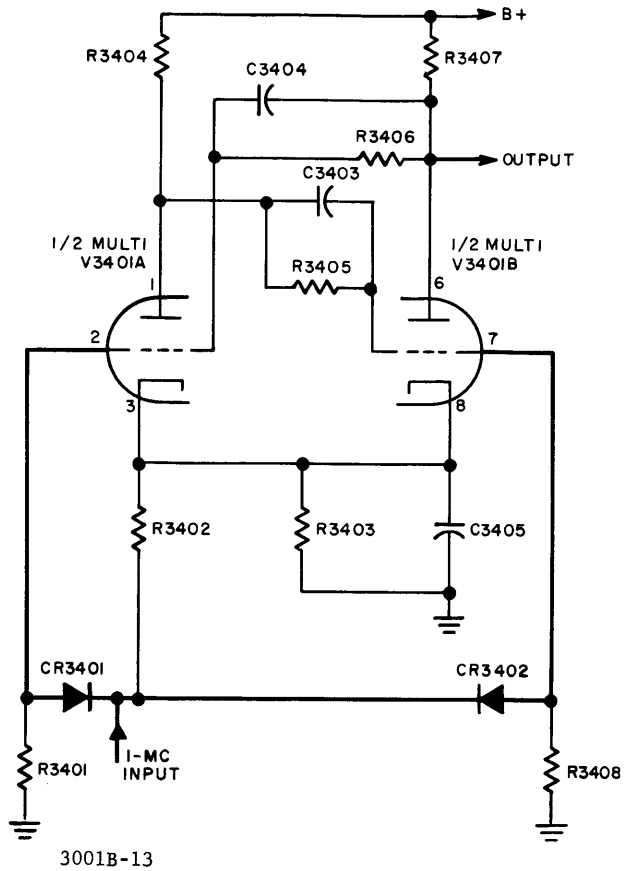


Figure 4-9. Multivibrator Circuit and Waveforms

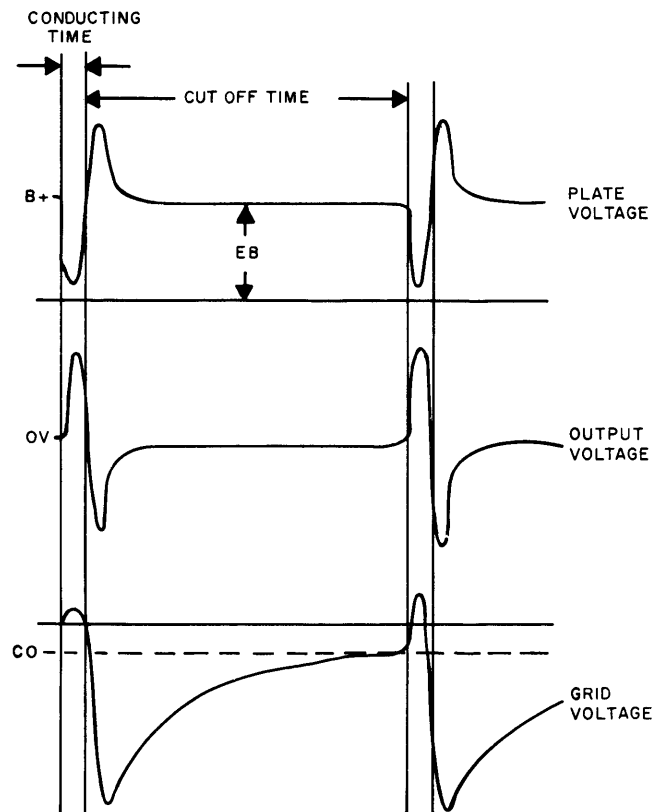
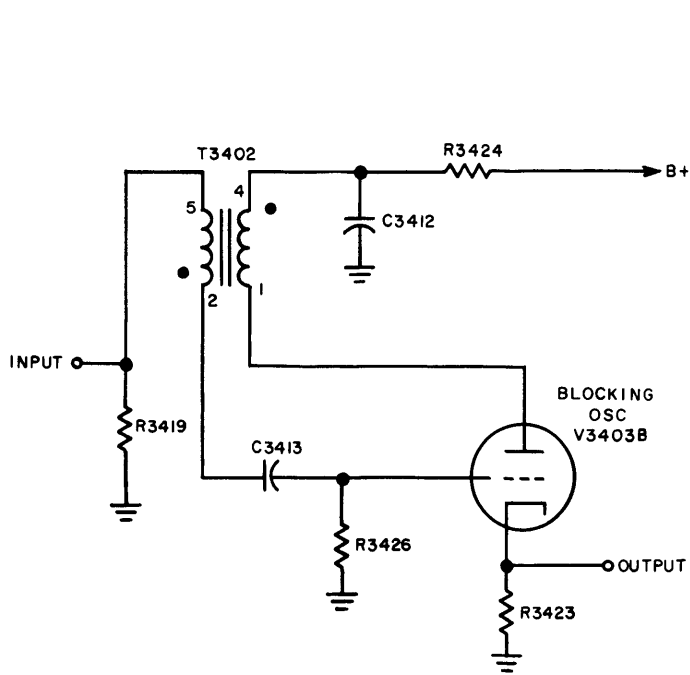


Figure 4-10. Block Oscillator and Waveforms

In this circuit, the 3.25 to 4.25-mc output from V3405 is coupled through T3405 to CR3409 and CR3410 which alternately conduct on each half-cycle. Thus the output at the wiper of the balance adjust is zero. The 3.25 to 4.25-mc output from V3406 is coupled through diodes CR3408 to CR3411. Normally, this signal is in phase with the other 3.25 to 4.25-mc signal and no voltage appears at R3442. Any difference in phase between the two signals is coupled through R3443 to the VARICAP output jack J3405 and to audio sync tone jack J3406.

4-7. DETAILED CIRCUIT ANALYSIS OF 3500-3600 DECK. (See figure 4-13.)

a. AMPLIFIER V3501B AND HARMONIC GENERATOR V3501A. The 1-mc standard signal from the 3100 deck is coupled from J3501 to amplifier V3501B through C3569, R3506, and parasitic suppressor PS3501. The plate circuit of V3501B is tuned by the primary of T3505. One output from V3501B is coupled to 1-mc output jack J3502; another output is coupled to V3503; and still another output is coupled through C3562 to the grid of second harmonic generator V3501A. T3503, in the plate circuit of V3501A, is tuned to 2 mc. The 2-mc output at the secondary of T3503 is coupled to 2-mc output jack J3505.

b. PULSE GENERATOR V3503. The 1-mc signal coupled to pulse generator V3503 is purposely distorted to produce harmonics of the 1-mc signal since the 8th through 37th harmonics of the 1-mc input is needed. The output from V3503 is applied to low pass filter Z3502 through a differentiator network comprised of C3610 and R3530. The differentiator network has an exceptionally short time constant in comparison with the 1-usec period of the 1-mc signal. The output of the low pass filter is coupled to the cathode circuit of 40.5-mc converter V3506.

c. OSCILLATOR V3502, AMPLIFIER V3504, CONVERTER V3506. Crystal oscillator V3502 generates frequencies between 48.5 and 77.5 mc. Selector switches S3501D and S3501C select one of 30 crystals operating between 48.5 and 77.5 mc. The output from V3502 is applied to V3505 and V3504. The signal is amplified through V3504 and coupled to the screen grid of converter V3506. The 8 to 37-mc signal from V3503 is heterodyned with the 48.5 to 77.5-mc signal to produce a 40.5-mc output.

Since V3502 is an independent oscillator and not locked to the 1-mc standard, it is subject to drift and, as a result, it is important that any error introduced by this drift be cancelled out. Figure 4-12, below, illustrates how this error is cancelled out. F1, in the illustration, is the HFO frequency; F2 is the output of V3502; and F3 is the appropriate harmonic of 1-mc.

d. AMPLIFIERS V3508 AND V3510. The 40.5-mc converter signal is amplified through pentode amplifiers V3508 and V3510. V3508 is tuned by L3528 and C3628 while V3510 is tuned by L3522 and C3625. Parasitic suppressors are incorporated in the grid and plate circuits of these two stages. The output from V3510 is coupled to the control grid of V3511, the final converter stage in the frequency synthesizer.

e. CONVERTER V3505, AMPLIFIER V3507, V3509. A sample of the HFO frequency in the Model HFR-1 arrives at J3503. This signal is between 3.75 and 33.75 mc, and is maintained 1.75 mc above the assigned receiver frequency. From J3503, this signal is coupled to low pass filter Z3501 which has a cut-off frequency of 34 mc. The output from Z3501 is applied to the cathode circuit of 43.75 to 44.75-mc converter V3505. The HFO input, a signal between 48.5 and 77.5 mc as selected by S3501, is coupled to the cathode of V3505. The plate circuit of V3505 contains a double-tuned circuit, configured by T3501, C3581, and C3582.

The output of V3505 is applied to cascaded amplifiers V3507 and V3509. The plate circuit of V3507 contains a double-tuned circuit, configured by T3502, C3588 and C3590. The plate circuit of V3509 contains a resonant tank, configured by L3520, C3594, and trimmer C3593. The resonant tank is damped by R3519 to obtain the required bandpass characteristic.

f. CONVERTER V3511 AND AMPLIFIER V3512. The 43.75 to 44.75-mc signal from V3509 is applied to the grid (pin 7) of converter V3511. V3511 also receives the 40.5-mc signal from amplifier V3510. This converter produces a difference frequency between 3.25 and 4.25 mc which is coupled to the grid (pin 1) of amplifier V3512. The 3.25 to 4.25-mc output from V3512 is taken from T3504 and coupled to J3504. The output signal which contains any errors of the HFO circuit, is coupled to the phase detector circuit in the 3400 deck.

4-8. DETAILED CIRCUIT ANALYSIS OF 3700 DECK. (See figure 4-14.)

The 3700 deck is a regenerative divider circuit which generates a 250-kc output from the 1-mc reference input. The 250-kc output is used as: (1) a synthesized carrier in the Model HFA-1 Audio Amplifier, and (2) as a synthesized injection frequency in the alignment generator section of the Model HFR-1 Continuous RF Tuner.

The 1-mc input is coupled through J3701 and voltage step-up transformer T3701 to cathode follower V3701, V3701 acts as a buffer for V3702. The output from V3701 is coupled through C3702 to the control grid (pin 1) of converter V3702.

V3702 operates in conjunction with tripler V3703A. Initially V3703A acts as a noise generator (this is before the tube stabilizes). When power is first applied, plate current flows and the resultant noise at 750 kc is amplified and coupled to the grid (pin 7) of V3702. With a 1-mc signal applied at the control grid of V3702, and a 750-kc noise signal at the screen grid, a mixing action occurs producing a small 250-kc signal at the plate. This small 250-kc signal is applied to the control grids of V3703A and V3703B.

The small component of 250 kc delivered to the grid of V3703A is tripled to produce an increased value of 750-kc signal in the plate circuit. This

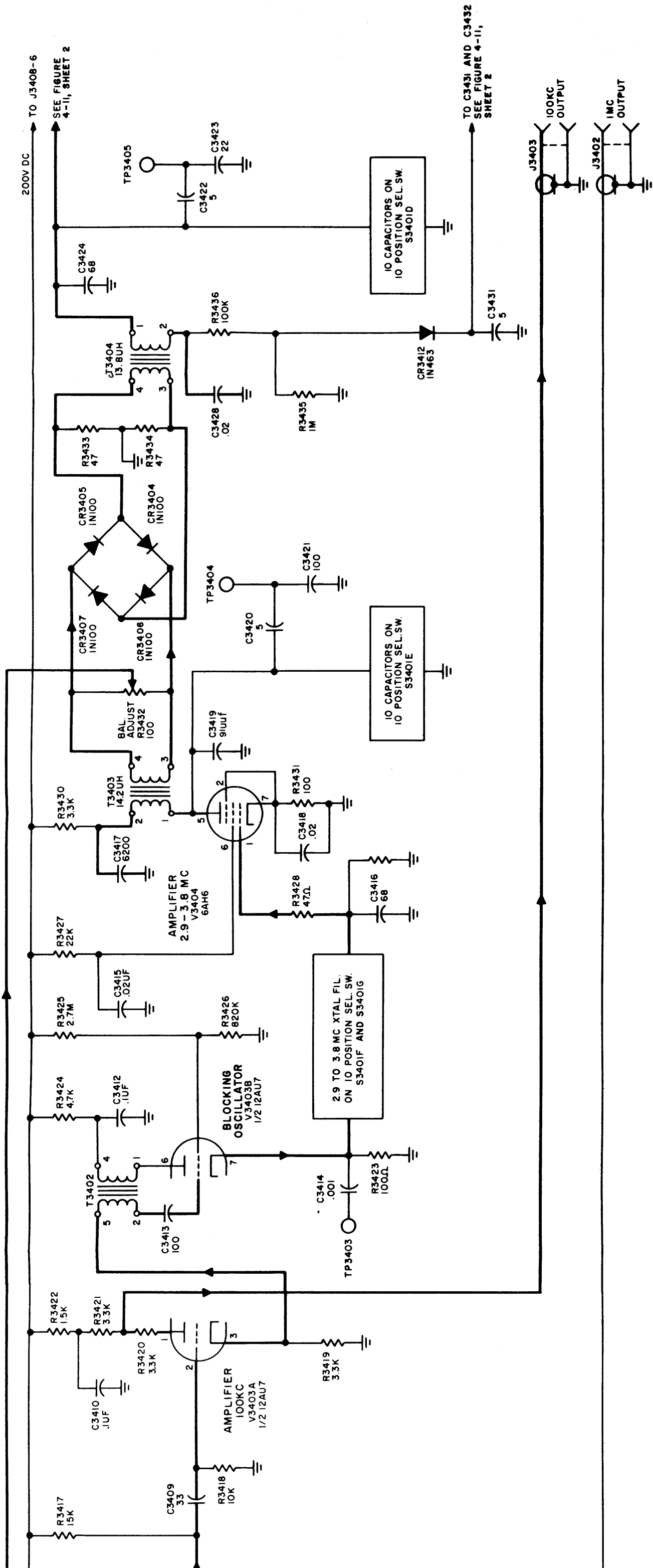
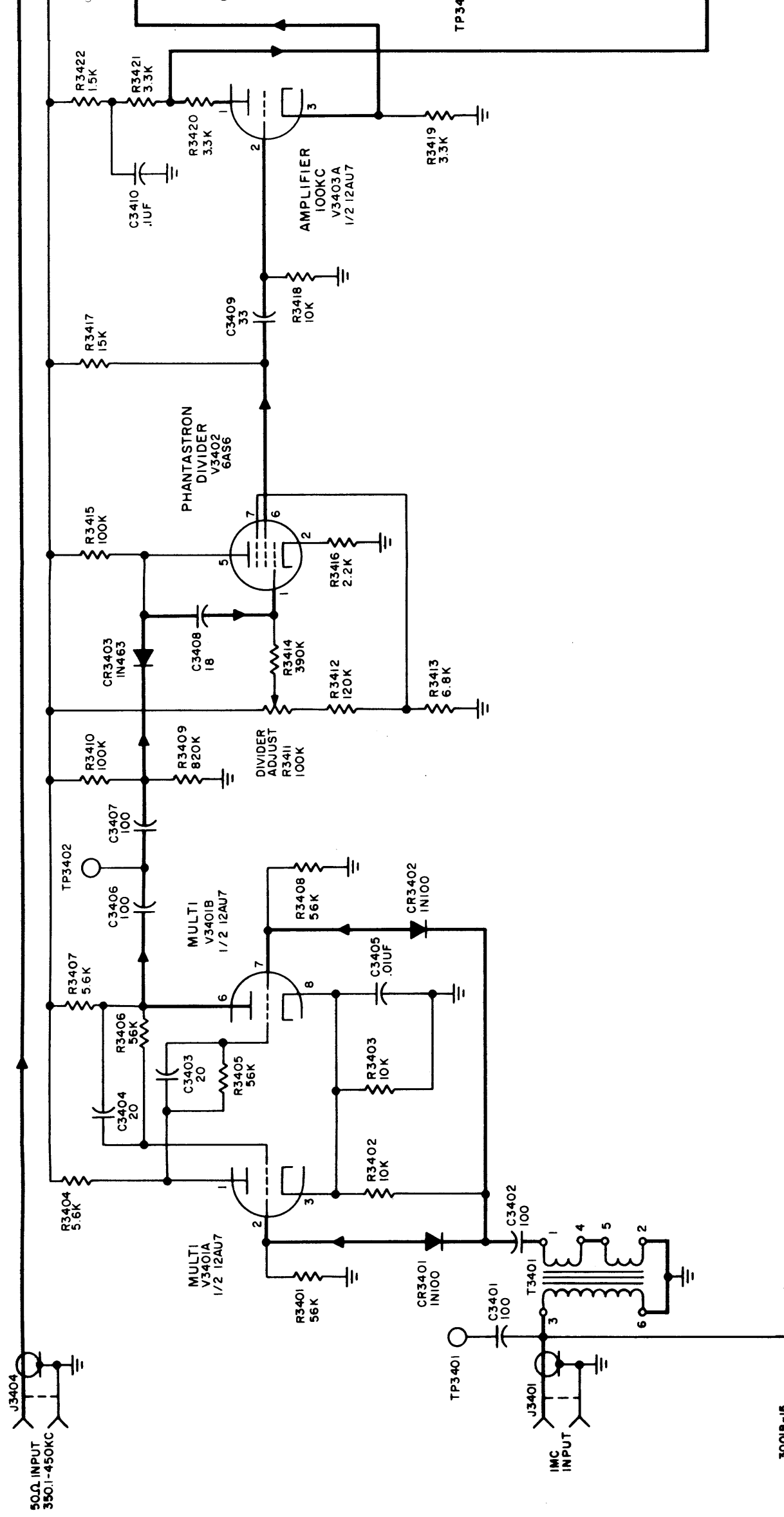


Figure 4-11. 3400 Deck, Simplified Schematic Diagram (Sheet 1 of 2)



3001B-15

109653001B

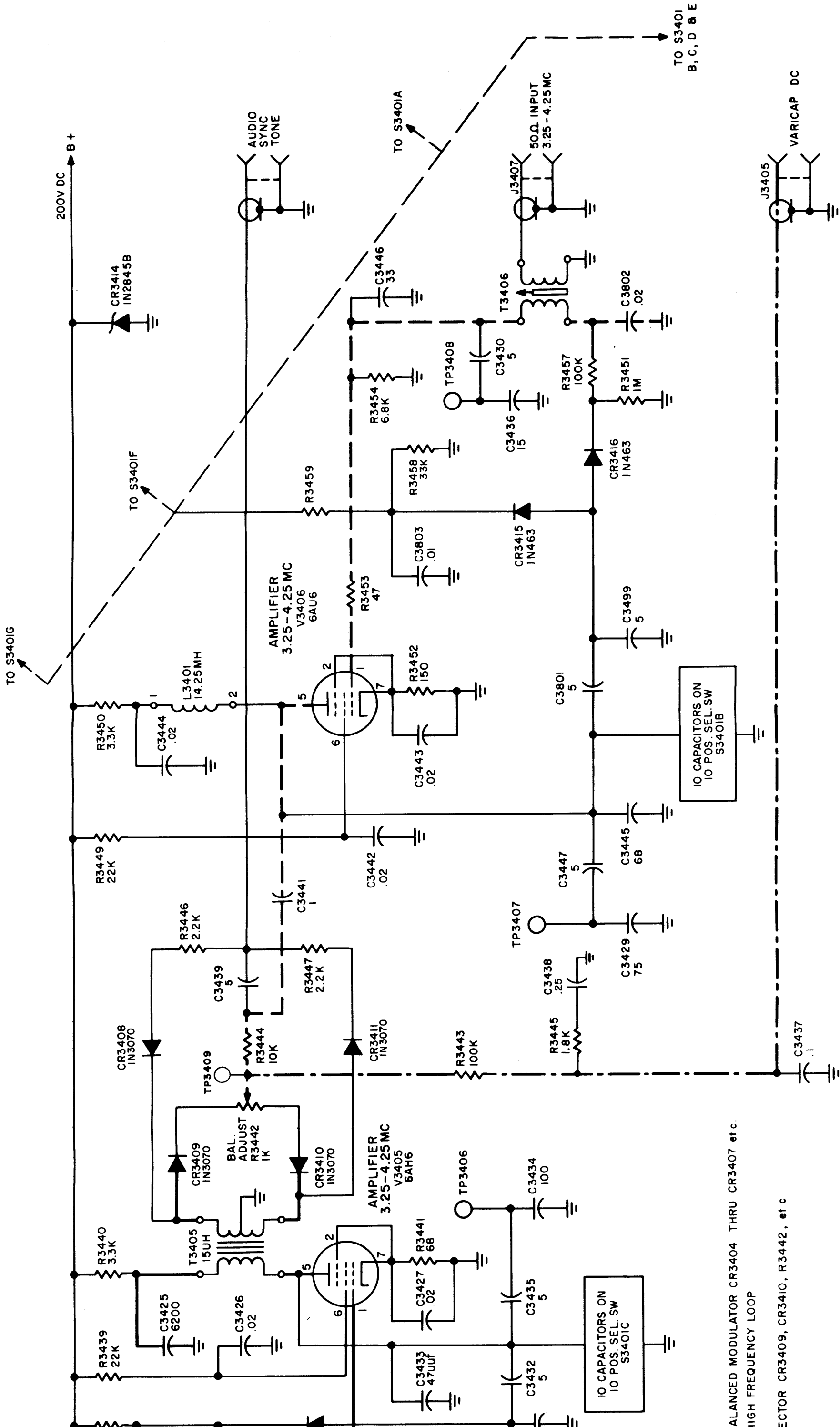
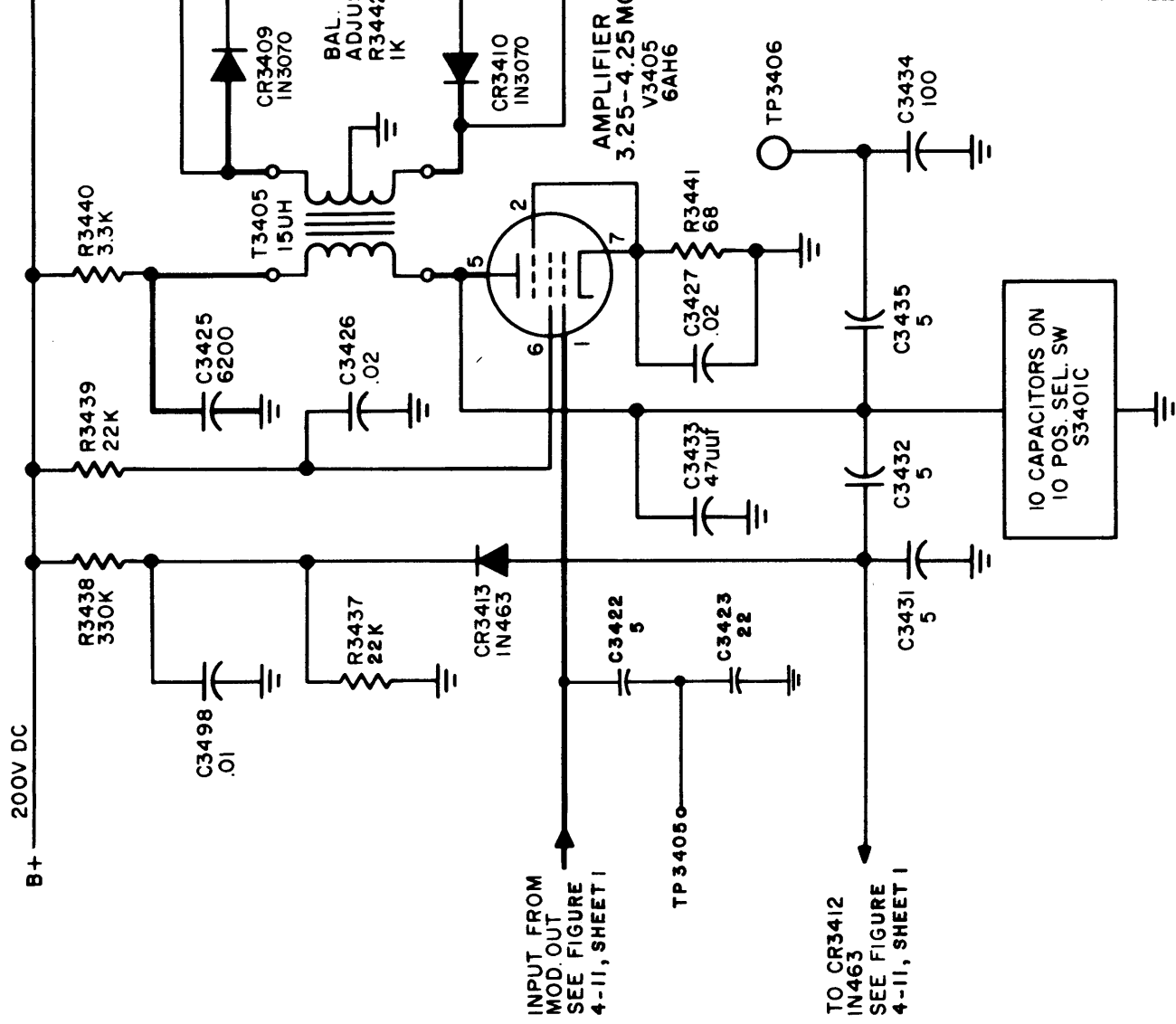


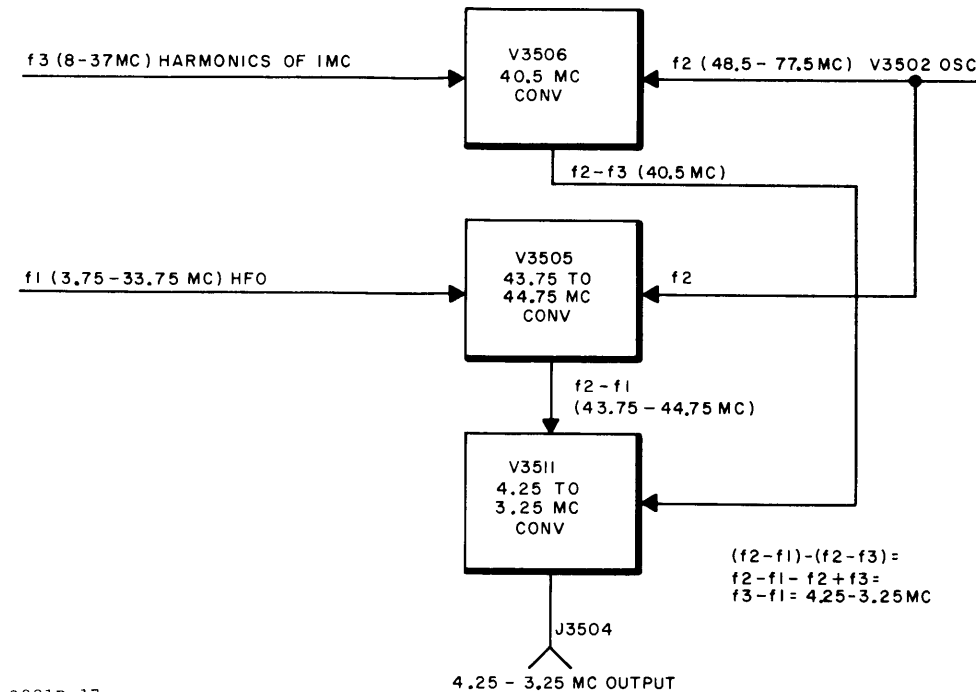
Figure 4-11. 3400 Deck, Simplified Schematic Diagram (Sheet 2 of 2)



- 3.25-4.25 MC FROM BALANCED MODULATOR CR3404 THRU CR3407 et
- - - 3.25-4.25 MC FROM HIGH FREQUENCY LOOP
- · - · - DC FROM PHASE DETECTOR CR3409, CR3410, R3442, et c

3001B-16

109653001B



3001B-17

Figure 4-12. Drift Cancelling Network

signal is fed back to a grid (pin 7) of V3702. This cycle continues until the circuit stabilizes and a healthy 750-kc signal is produced at the plate of V3703A. The 250-kc signal is finally amplified in V3703B. The output from V3703B is coupled to 250-kc output jack J3702 which, in turn, connects to output jacks J3015 through J3018.

4-9. MAIN CHASSIS (3000 DECK) DESCRIPTION.

The 3000 deck contains the input and output terminal connections, nixie indicators, the 1 MC COMPARATOR front panel meter, the filter panel, and the transistor operated sync relay (K3001).

Figure 4-15 shows a typical nixie selector indicator with its associated circuitry. Six of these type nixies are found in the HFS-1. The nixies indicate the frequency of the incoming signal, not the synthesizer frequency, and are controlled by the .1 KC, 1 KC, 10 KC, 100 KC, and 1 MC front panel controls. In the 3400 deck, wafers S3401A through S3401G are interconnected into various tuned networks and by placing S3401 in various positions, various signals corresponding to the desired digit is coupled to the nixie. This signal, in the illustration shown, is coupled through JP3408 to the appropriate pin on nixie base XDS3400. Twenty-eight volts dc, coupled through J3409, is used as the nixie operating voltage. In the 3100 deck, switch wafers S3101A through S3101D are interconnected into various tuned net-

works in V3102 through V3104. In the 3200 deck, switch wafers S3201A through S3201E are connected to tuned circuits in the balanced modulator and in V3202 and V3204. In the 3300 deck, switch wafers S3301A through S3301F are connected to tuned circuits in V3302 through V3304 and the balanced modulator. In the 3500 deck, switch wafers S3501A through S3501D are connected into various tuned circuits.

The 1 MC COMPARATOR meter (M3001) is coupled to the phase comparator circuit in the 3100 deck through J3106. The phase difference between the two 1-mc signals is indicated by the rate of swing at the meter. Sync balance control R3140 is used as a meter zero adjust.

Transistor Q3001 and relay K3001 form an audio sync control network. With no audio sync tone from the quadrature phase detector (see paragraph 4-6e) in the 3400 deck, the collector circuit of Q3001 passes in sufficient current to energize K3001. Hence contact N of J3001 is grounded and contact J is open. This results in the SYNC IND light at the HFR-1 Continuous RF Tuner extinguishing an indication that the unit is not in sync. With an audio sync tone output coupled to the base of Q3001, Q3001 activates thus grounding contact J of J3001. This results in relay K7001 in the HFA-1 Audio Amplifier activating and the SYNC IND light at the HFR-1 lighting. With K7001 activated, the audio sync tone connected to J7002 at the HFA-1 is substituted for the demodulated audio.

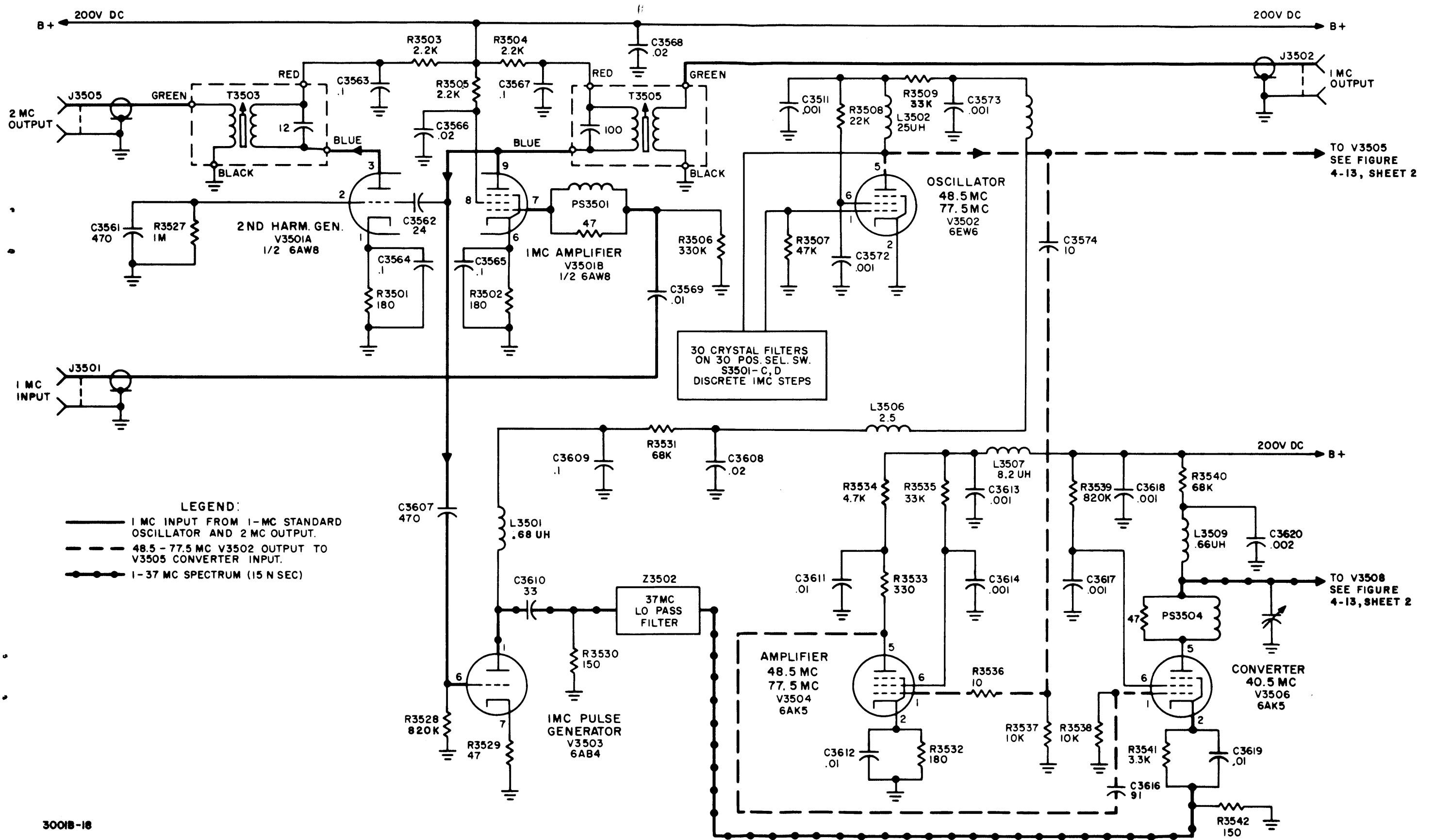
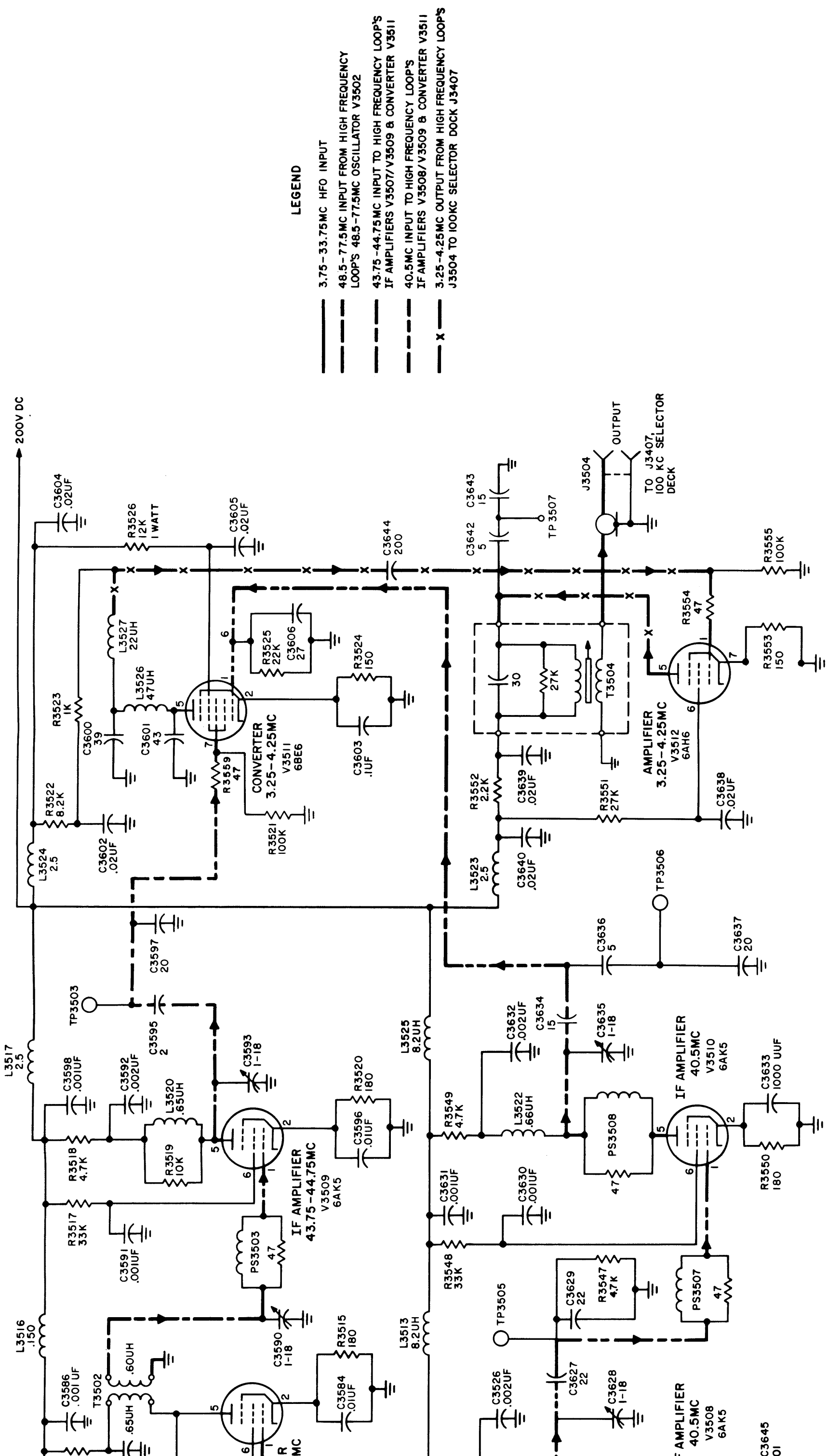


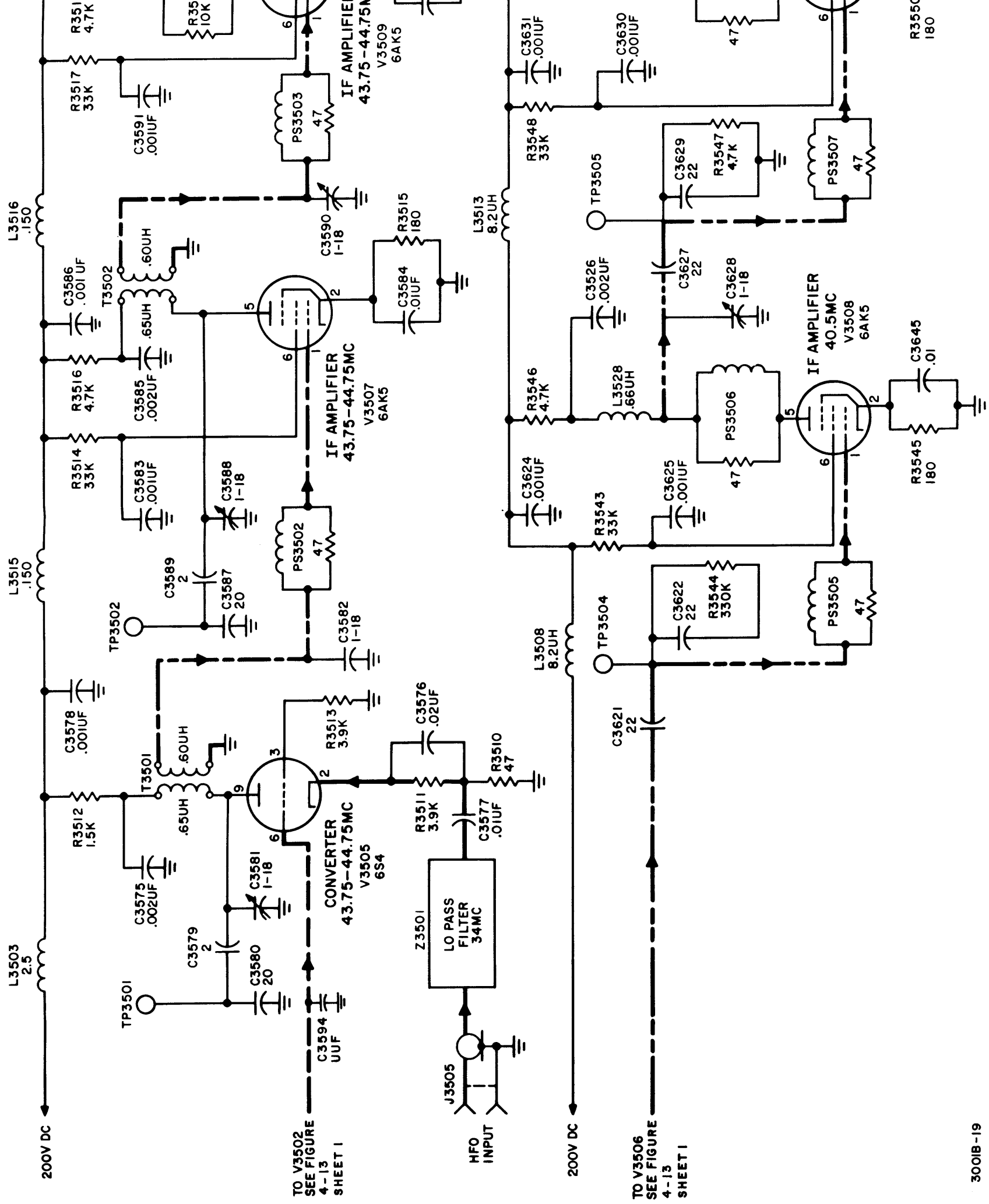
Figure 4-13. 3500-3600 Deck, Simplified Schematic Diagram (Sheet 1 of 2)

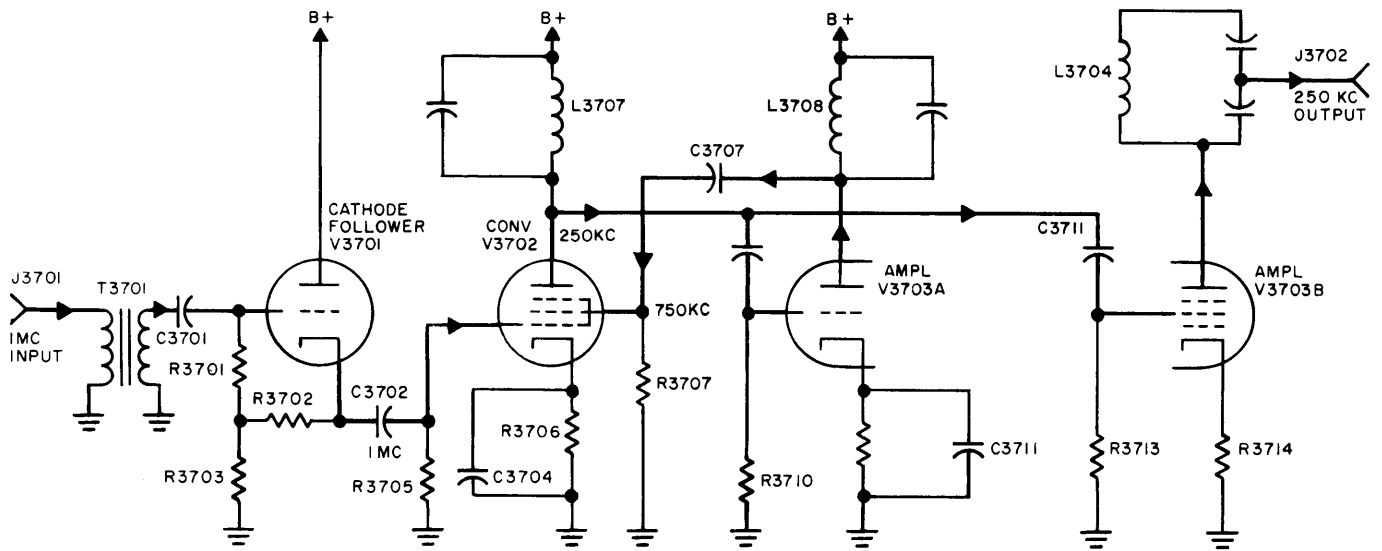


LEGEND

- 3.75-33.75MC HFO INPUT
- 48.5-77.5MC INPUT FROM HIGH FREQUENCY LOOPS 48.5-77.5MC OSCILLATOR V3502
- 43.75-44.75MC INPUT TO HIGH FREQUENCY LOOP'S IF AMPLIFIERS V3507/V3509 & CONVERTER V3511
- 40.5MC INPUT TO HIGH FREQUENCY LOOP'S IF AMPLIFIERS V3508/V3509 & CONVERTER V3511
- X 3.25-4.25MC OUTPUT FROM HIGH FREQUENCY LOOP'S J3504 TO 100KC SELECTOR DOCK J3407

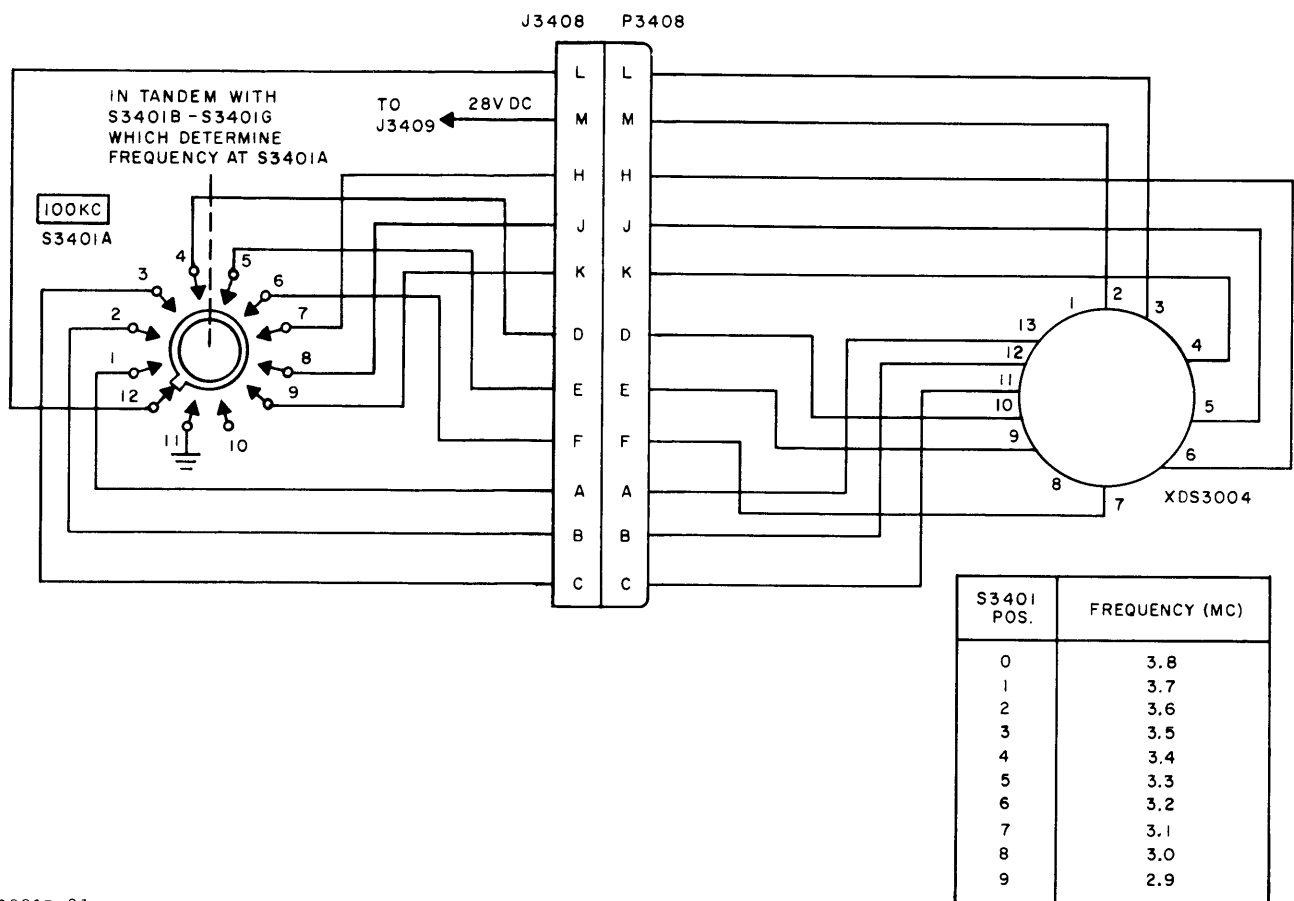
Figure 4-13. 3500-3600 Deck, Simplified Schematic Diagram (Sheet 2 of 2)





3001B-20

Figure 4-14. Regenerative Divider (High Frequency Loop)



3001B-21

Figure 4-15. Typical Nixie Indicator Connection

SECTION 5 TROUBLESHOOTING

5-1. GENERAL.

This section discusses troubleshooting techniques to be used in determining malfunctions in the equipment. As part of these troubleshooting procedures, a preliminary inspection is given as a visual aid to determine conditions which may have caused equipment breakdown. This preliminary inspection is followed by a procedure for verification of required voltage and resistance measurements. This is followed by a systematic analysis of troubleshooting which should indicate the possible functional section at fault

within the equipment. Once the particular functional section at fault is located, by following table 5-5, the particular component at fault within the functional section can be determined.

5-2. TEST EQUIPMENT NEEDED.

The test equipment required for verifying voltage and resistance measurements is listed in table 5-1, below. This is followed by table 5-2 which lists the test equipment required for troubleshooting the HFS-1.

TABLE 5-1. VOLTAGE AND RESISTANCE TEST EQUIPMENT.

QUANTITY REQUIRED	EQUIPMENT	TYPE
2	Signal generator	Must provide 1 mc. at 1.5 vrms and 3.75 mc. at 20 mv. rms.
1	Power supply	Must provide +200 vdc at 0.5a. and 6.3 vac at 15 a., 60 cps.
1	Simpson Model 260	Volt-ohm-milliammeter, 20,000 ohms-per-volt.
1	Dummy load	47 ohm, 1/2 watt resistor, mounted on RG-174/U cable. Cable equipped with TMC-PL-204 plug or equivalent.
1	Dummy load	56 ohm, 1/2 watt resistor, mounted on RG-174/U cable. Cable equipped with TMC-PL-204 plug or equivalent.
1	Dummy load	27 ohm, 1/2 watt resistor, mounted on RG-174/U cable. Cable equipped with TMC-PL-204 plug or equivalent.
1	Test socket adapter	7-pin miniature.
1	Test socket adapter	9-pin miniature.
1	Power cable	Must provide: (1). +200 vdc from power supply to pin K of J3001 on HFS. (2). 6.3 vac from power supply to pin A, pin B, pin E and pin R of J3001 on HFS. (3). Common ground connection between power supply and HFS at pin D, pin F, pin H and pin P of J3001 on HFS.

TABLE 5-2. TROUBLESHOOTING TEST EQUIPMENT

NAME	MODEL
Oscilloscope	Tektronics Type 545A or equivalent
RF VTVM	Ballantine 314 or equivalent

5-3. UNIT TROUBLESHOOTING .

a. **PRELIMINARY CHECK.** A preliminary check should be performed on the HFS-1, while it is turned off, in an effort to correct conditions which might lead to a breakdown of components. Table 5-3 lists the preliminary inspection procedures.

TABLE 5-3. PRELIMINARY INSPECTION PROCEDURES

WHAT TO INSPECT	DEFECTS TO LOOK FOR	REMEDIES
All electrical connections at rear of equipment.	Open connections, dirt, oil, frayed cables.	Replace or clean as necessary.
Knobs, screws, connectors.	Loose or missing hardware.	Tighten or replace.
Wiring	Loose or frayed wires.	Resolder or rewire.
Solder joints	Loose or cold solder connections.	Resolder or clean as necessary.
Switches	Bad connections, broken wipers.	Fix or replace as necessary.
Frequency Indicator	Burned out nixies or loose connections.	Replace nixie or fix connection as necessary.
Resistors	Cracks, chipping, blistering, discolorations, and other signs of overheating.	Replace defective resistor.
Capacitors	Leaks, bulges, discoloration.	Replace defective capacitor.
Tubes	Poor seating. Burned out or shorted.	Press tube firmly in socket. Replace defective tube.
Cables	Broken or loose cabling or connectors.	Tighten or replace.
Front panel meter.	Bent indicators, cracked case, broken glass.	Replace defective meter.

b. **VOLTAGE AND RESISTANCE CHART.** Table 5-4 lists each vacuum tube in the HFS and the voltage and resistance from each pin of the tube to ground. Refer to table 5-1 and the following procedure to verify required values.

(1) Remove top dust cover from HFS, and set 1 MC EXT/INT switch (located inside, on right side of chassis deck) at EXT.

(2) Connect 47 ohm dummy load to J3019 on rear of HFS chassis.

(3) Connect 27 ohm dummy load to J3012 on rear of HFS chassis.

(4) Connect 56 ohm dummy load to J3016 on rear of HFS chassis.

(5) Connect power cable from power supply to J3001 on rear of HFS chassis.

(6) Remove tube from socket at which voltage or resistance is to be measured.

WARNING

Make sure that power supply is turned off before performing step 7. If power supply is

turned on, 200 vdc will be present on the exposed contacts of the adapter when it is plugged in.

(7) Plug test adapter into tube socket, and plug tube into adapter.

(8) With power supply off, measure resistances from test adapter contacts to ground, and compare with readings in HFS-1 VOLTAGE AND RESISTANCE CHART.

(9) Remove meter leads from test adapter.

(10) (a) Connect first signal generator to J3009 on rear of HFS chassis.

(b) Adjust first signal generator output to 3.75 mc. at 20 mv.

(11) (a) Connect second signal generator to J3030 on rear of HFS chassis.

(b) Adjust second signal generator output to 1 mc. at approximately 1.5 v.

(12) Turn power supply on.

(13) Set HFS front panel controls so that nixie indicators indicate 2 mc.

(14) Measure voltages from test adapter contacts to ground, and compare with readings in HFS-1 VOLTAGE AND RESISTANCE CHART.

(15) Remove meter leads from test adapter.

(16) Turn power supply off.

(17) Remove test adapter and replace tube in socket.

(18) Remove dummy loads and signal generators.

c. TROUBLESHOOTING CHART. Table 5-5 outlines a systematic approach for troubleshooting the unit to find what particular functional section is at fault within the unit. Before troubleshooting the equipment, make sure that all external power and signal connections are made both at the rear of the equipment and on the chassis itself. There is no power switch on the HFS-1 and it is turned on and off at the power supply.

Since the HFS-1 is an integral part of the DDR-5 Receiver, any malfunction in the synthesizer will ultimately manifest itself at the DDR-5. Indications of synthesizer malfunction occur when (1) The SYNC IND light on the HFR-1 goes out; (2) The 1 MC COMPARATOR meter on the HFS-1 stops fluctuating and drops to zero; or (3) Sideband intelligence becomes garbled.

TABLE 5-4. VOLTAGE AND RESISTANCE CHART.

SYM. NO.		PIN NUMBER								
		1	2	3	4	5	6	7	8	9
V3101	V	+1.6	+14	6.3AC	0	+170	+75	+5.6		
	R	2.5 MEG	2.2K	0	0	65K	26K	7.5K		
V3102	V	+180	NC	6.3AC	0	NC	0	+6		
	R	26K	NC	0	0	NC	100K	32K		
V3103	V	0	+0.7	6.3AC	0	+125	+95	+0.7		
	R	110K	150	0	0	14K	25K	+150		
V3104	V	-3	+0.7	6.3AC	0	+125	+95	+0.7		
	R	130K	150	0	0	14K	36K	150		
V3105	V	+1.2	-0.6	+115	0	6.3AC	+1.1	-0.3	+90	+125
	R	500	65K	20K	0	0	150	63K	32K	13K
V3201	V	+2.8	+6.3	6.3AC	0	+125	+160	+5.5		
	R	1.8 MEG	2.2K	0	0	64K	28K	7.5K		

TABLE 5-4. VOLTAGE AND RESISTANCE CHART (CONT)

SYM. NO.		PIN NUMBER								
		1	2	3	4	5	6	7	8	9
V3202	V	+185	NC	6.3AC	0	NC	0	+8.4		
	R	28K	NC	0	0	NC	95K	32K		
V3203	V	-0.1	+0.55	6.3AC	0	+135	+115	+0.55		
	R	110K	45	0	0	15K	34K	45		
V3204	V	-3.8	+0.1	6.3AC	0	+165	+162	+0.1		
	R	23K	150	0	0	15K	35K	150		
V3301	V	+3.6	+7	6.3AC	0	+120	+150	+5.5		
	R	1.8 MEG	2.2K	0	0	62K	28K	7K		
V3302	V	+185	NC	6.3AC	0	NC	0	+8		
	R	27K	NC	0	0	NC	95K	31K		
V3303	V	0	+1.2	6.3AC	0	+140	+120	+1.2		
	R	110K	150	0	0	15K	35K	150		
V3304	V	-3.9	+1.1	6.3AC	0	+145	+120	+1.1		
	R	110K	150	0	0	15K	33K	150		
V3401	V	+155	+70	+75	0	6.3AC	+150	+70	+75	0
	R	14K	14K	10K	0	0	14K	14K	10K	0
V3402	V	+17	+16	6.3AC	0	+160	+80	+4.3		
	R	440K	2.4K	0	0	65K	26K	6.5K		
V3403	V	+165	-0.15	+5.2	0	6.3AC	+175	-8.4	0	0
	R	18K	10K	3.3K	0	0	15K	650K	100	0
V3404	V	0	+1.15	6.3AC	0	+150	+125	+1.15		
	R	105K	100	0	0	14K	32K	100		
V3405	V	0	+0.8	6.3AC	0	+145	+120	+0.8		
	R	150K	65	0	0	14K	34K	65		
V3406	V	0	+1.4	6.3AC	0	+155	+130	+1.4		
	R	160K	150	0	0	14K	32K	150		
V3501	V	+0.6	-1.6	+175	0	6.3AC	+3.4	0	+175	+150
	R	200	1.1 MEG	12K	0	0	200	330K	12K	12K

TABLE 5-4. VOLTAGE AND RESISTANCE CHART (CONT)

SYM. NO.		PIN NUMBER								
		1	2	3	4	5	6	7	8	9
V3502	V	-1.8	0	6.3AC	0	+150	+135	0		
	R	50K	0	0	0	14K	34K	0		
V3503	V	+70	NC	6.3AC	0	NC	-15	+0.1		
	R	75K	NC	0	0	NC	125K	50		
V3504	V	-0.15	+1.65	6.3AC	0	+153	+110	+1.65		
	R	11K	190	0	0	15K	45K	190		
V3505	V	NC	+10	0	0	6.3AC	0	NC	NC	+180
	R	NC	3.9K	108K	0	0	108K	NC	NC	12K
V3506	V	0	+2.4	6.3AC	0	+150	+36	+2.4		
	R	10K	3.8K	0	0	80K	900K	3.8K		
V3507	V	0	+1.75	6.3AC	0	+155	+90	+1.75		
	R	0	190	0	0	16K	45K	190		
V3508	V	0	+1.7	6.3AC	0	+155	+110	+1.7		
	R	350K	190	0	0	15K	43K	190		
V3509	V	0	+1.5	6.3AC	0	+155	+112	+1.5		
	R	0	190	0	0	15K	43K	190		
V3510	V	0	+1.6	6.3AC	0	+155	+110	+1.6		
	R	325K	190	0	0	15K	45K	190		
V3511	V	0	+1.55	6.3AC	0	+155	+85	0		
	R	23K	145	0	0	20K	23K	110K		
V3512	V	0	+1.3	6.3AC	0	+172	+115	+1.3		
	R	110K	150	0	0	12K	38K	150		
V3701	V	+195	NC	6.3AC	0	NC	+22	+38		
	R	12K	NC	0	0	NC	115K	8.5K		
V3702	V	-10	+1.1	6.3AC	0	+145	+70	-14		
	R	22K	150	0	0	19K	31K	105K		
V3703	V	+200	-0.1	+130	0	6.3AC	+200	+1.7	+5.8	0
	R	10K	108K	41K	0	0	10K	210	680	350K



Note: Voltage readings are in volts, $\pm 10\%$, to ground.

Resistance readings are in ohms, $\pm 10\%$, to ground. Resistance measurements in stages containing diodes will vary depending upon polarity of meter.

TABLE 5-5. UNIT TROUBLESHOOTING CHART

STEP	PRELIMINARY ACTION	NORMAL INDICATION	NEXT STEP
1	Connect HFS-1 into DDR-5 system. Make all connections and apply power.	Tubes should light and B+ should be applied to the various stages within the HFS-1. Check B+ line to ground with ohmmeter - reading should be infinite.	If indication is abnormal, check HFR-1 and system and unit cabling and connections. If indications are normal, proceed to step 2.
2	Tune system to any desired frequency between 2 and 32 mc. Place TUNE-SYNC-OPERATE switch on HFR-1 in OPERATE position. Tune HFR-1 in 100 cps increments between 000 and 900 cycles. Thus turn .1 KC switch to selected frequency and determine sync at each frequency. (.1 KC switch should be rotated between "0" and "9.")	Sideband intelligence is readily discernable at each frequency. SYNC IND light at HFR-1 should remain lit. 1 MC COMPARATOR meter at HFS-1 working properly.	If indication is abnormal, see step 1 in table 5-6. If indication is normal, proceed to step 3.
3	Repeat "preliminary action" in step 2, above. However, tune HFR-1 in 1-kc increments between 0 and 9000 cycles. Thus turn 1 KC switch to selected frequency and determine sync at each frequency. (1 KC switch should be rotated between "0" and "9.")	Same as "normal indication" in step 2, above.	If indication is abnormal, see step 6 in table 5-6. If indication is normal, proceed to step 4.
4	Repeat "preliminary action" in step 2, above. However, tune HFR-1 in 100-kc increments between 0 and 900-kc. Thus turn 100 KC switch to selected frequency and determine sync at each frequency. (100 KC switch should be	Same as "normal indication" in step 2, above.	If indication is abnormal, see step 16 in table 5-6. If indication is normal, proceed to step 5.

TABLE 5-5. UNIT TROUBLESHOOTING CHART (CONT'D)

STEP	PRELIMINARY ACTION	NORMAL INDICATION	NEXT STEP
4 (cont.)	rotated between "0" and "9.")		
5	Repeat "preliminary action" in step 2, above. However, tune HFR-1 in 1-mc steps between 2 and 32-mc. Thus turn 1 MC switch to selected frequency and determine sync at each frequency.	Same as "normal indication" in step 2, above.	If indication is abnormal, see step 28 in table 5-6. If indication is normal, proceed to step 6.
6	Connect on oscilloscope alternately to 250-kc output jacks J3015 through J3018 and note signals.		If indication is abnormal, see step 38 in table 5-6. If indication is normal, proceed to step 7.
7	Connect oscilloscope alternately to 2-mc output jacks J3010 through J3013 and note signals.		If indication is abnormal, see step 28 in table 5-6.

5-4. FUNCTIONAL SECTION TROUBLESHOOTING.

a. **PRELIMINARY CHECK.** The functional sections of the HFS-1 should be visually checked in an effort to locate trouble-spots. A handy guide for this preliminary check is shown in table 5-3.

b. **FUNCTIONAL SECTION TROUBLESHOOTING CHART.** Table 5-6 outlines a systematic approach to troubleshooting the various functional sections of

the HFS-1. Before troubleshooting make sure that all external power and signal connections are made. If it is indicated that a particular functional section is not tuned for an optimum output or there is indication that alignment is needed, see section 6 of this manual. Note that all oscilloscope readings in table 5-6 are given in peak-to-peak voltages unless otherwise specified. Refer to figures 5-1 and 5-2 which show test points and component locations.

TABLE 5-6. FUNCTIONAL SECTION TROUBLESHOOTING CHART


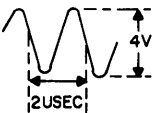

STEP	POINT	PRELIMINARY ACTION	NORMAL INDICATION	NEXT STEP
1	1	Connect oscilloscope at J3103.		If indication is normal, proceed to step 3. If indication is abnormal, proceed to step 2.
2	A1	Connect oscilloscope to terminal 6 on Z3101 and adjust scope for .5 usec/cm.		If indication is normal, check V3105, T3102, and associated circuitry. If indication is abnormal, check Z3103.
3	2	Connect oscilloscope to TP3103 and adjust scope for 50 usec/cm. Place .1 KC switch at "0."		If indication is normal, proceed to step 6. If indication is abnormal, see step 4.

TABLE 5-6. FUNCTIONAL SECTION TROUBLESHOOTING CHART (CONT'D)


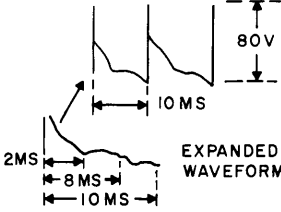
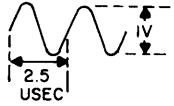
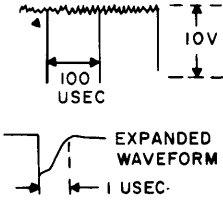
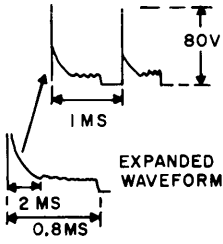
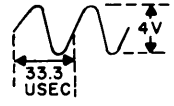
STEP	POINT	PRELIMINARY ACTION	NORMAL INDICATION	NEXT STEP
3 (cont.)		Vary .1 KC switch.		If indication is abnormal, see step 4.
4	(B1)	Connect oscilloscope to TP3101 and adjust scope for .5 ms/cm.		If indication is normal, proceed to step 5. If indication is abnormal, any of the other decks may be at fault.
5	(B2)	Connect oscilloscope to TP3102 and adjust scope for 2 ms/cm.		If indication is normal, check V3103, V3104 and associated circuitry. If indication is abnormal, readjust R3104.
6	3	Connect oscilloscope to TP3205 and adjust scope for 5 usec/cm. .1 KC switch in 0 position and 1 KC switch in 0 position. (This is equivalent to 40 kc).		If indication is normal, proceed to step 11 below. If indication is abnormal, check V3204, T3203 and J3204.
7	(C1)	Connect oscilloscope to TP3201 and adjust scope for 20 us/cm.		If indication is normal, proceed to step 8. If indication is abnormal, one of the other decks, J3201, or cabling is at fault.
8	(C2)	Connect oscilloscope to TP3202 and adjust scope for .2 ms/cm.		If indication is normal, proceed to step 9. If abnormal indication exists, adjust T3203.
9	(C3)	Connect oscilloscope to TP3203 and adjust scope for 5 usec/cm. Place 1 KC switch in "7" position. This corresponds to a frequency of 30 kc.		If indication is normal, proceed to step 10. If indication is abnormal, check V3203, T3201, and associated tuned circuits.

TABLE 5-6. FUNCTIONAL SECTION TROUBLESHOOTING CHART (CONT'D)

STEP	POINT	PRELIMINARY ACTION	NORMAL INDICATION	NEXT STEP
10	(C4)	<p>Connect oscilloscope to TP3204 and adjust scope for 5 usec/ cm.</p> <p>Set .1 KC selector to "0" and 1 KC selector to "0." This corresponds to a frequency of 40 kc.</p>		<p>If indication is normal, check V3204.</p> <p>If indication is abnormal, first check that a 3.1 to 4-kc signal exists at R3219. Then check CR3202, T3202 and associated tuned circuits.</p>
11	(4)	<p>Connect oscilloscope at TP3305 and adjust scope for 1 usec/cm.</p> <p>Place .1 KC in "0" position, 1 KC in "0" and 10 KC in "5." This corresponds to a frequency of 400 kc.</p>		<p>If indication is normal, proceed to step 16.</p> <p>If indication is abnormal, check V3304, T3303, J3304, and associated circuitry.</p> <p>If indication is still abnormal, proceed to step 12.</p>
12	(D1)	<p>Connect oscilloscope at TP3301 and adjust scope for 2 usec/cm.</p>		<p>If indication is normal, proceed to step 13.</p> <p>If indication is abnormal, check J3301, cabling, and other decks.</p>
13	(D2)	<p>Connect oscilloscope at TP3302 and adjust scope for 20 usec/cm.</p>		<p>If indication is normal, proceed to step 14.</p> <p>If abnormal indication exists, readjust divider adjust control R3303.</p> <p>If indication is abnormal, check V3301, V3302, CR3301, and associated circuitry.</p>
14	(D3)	<p>Connect oscilloscope to TP3303 and adjust scope for 1 usec/cm.</p> <p>Place 10 KC selector in "1" position. This corresponds to 400-kc.</p>		<p>If indication is normal, proceed to step 15.</p> <p>If indication is abnormal, check V3303 and associated tuned circuits.</p>
15	(D4)	<p>Connect oscilloscope to TP3304.</p> <p>Place .1 KC selector in "0", 1 KC selector in "0", and 10 KC selector in "5." This corresponds to 400 kc.</p>		<p>If indication is normal, check V3304.</p> <p>If indication is abnormal, first check to see that a 30.1 to 40-kc signal is coupled across R3330. Then check T3301, CR3302, and associated balanced modulator circuitry.</p>

TABLE 5-6. FUNCTIONAL SECTION TROUBLESHOOTING CHART (CONT'D)

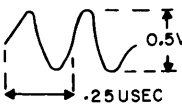
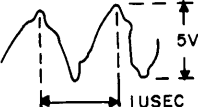
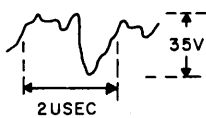
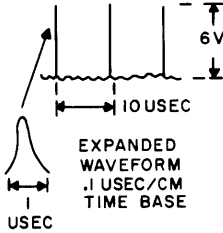


STEP	POINT	PRELIMINARY ACTION	NORMAL INDICATION	NEXT STEP
16	5	<p>Connect oscilloscope to TP3408 and adjust scope for .1 usec/cm.</p> <p>Nixies set to 02.2600.</p>		<p>If indication is normal, proceed to step 28.</p> <p>If indication is abnormal, proceed to step 17.</p>
17	E1	<p>Connect oscilloscope to TP3401 and adjust scope for .5 usec/cm.</p>		<p>If indication is normal, proceed to step 18.</p> <p>If indication is abnormal, check cabling, J3401, and 1-mc source in 3100 deck.</p>
18	E2	<p>Connect oscilloscope to TP3402.</p>		<p>If indication is normal, proceed to step 19.</p> <p>If indication is abnormal, check V3401, T3401, CR3401, CR3402, and associated circuitry.</p>
19	E3	<p>Connect oscilloscope to TP3403 and adjust scope to 2 usec/cm.</p>		<p>If indication is normal, proceed to step 20.</p> <p>If indication is abnormal, adjust divider adjust control R3411.</p> <p>If indication is still abnormal, check CR3403, V3402, V3403 and associated tuned circuits.</p>
20	E4	<p>Connect oscilloscope to TP3404 and adjust scope to 0.1 usec/cm.</p> <p>Set 100 kc selector at position "8." This corresponds to 3 mc.</p>		<p>If indication is normal, proceed to step 21.</p> <p>If indication is abnormal, check V3404 and associated circuitry.</p>
21	E5	<p>Connect oscilloscope to TP3405.</p> <p>Place .1 KC in "0," 1 KC in "0," 10 KC in "5," and 100 KC in "2." This corresponds to a frequency of 4 mc.</p>		<p>If indication is normal, proceed to step 22.</p> <p>If indication is abnormal, first check that a 350.1 to 450-kc signal exists on R3432.</p> <p>If indication is still abnormal, check R3432, CR3404 through CR3407, T3404, R3433, R3434 and associated tuned circuits.</p>

TABLE 5-6. FUNCTIONAL SECTION TROUBLESHOOTING CHART (CONT'D)

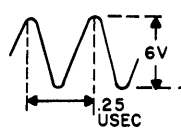
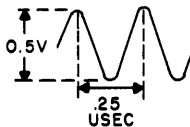
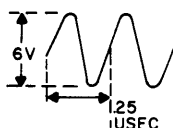

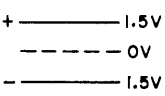
STEP	POINT	PRELIMINARY ACTION	NORMAL INDICATION	NEXT STEP
22	(E6)	Connect oscilloscope to TP3406.		If indication is normal, proceed to step 23. If indication is abnormal, check CR3412, C3431, CR3413, C3432, C3435, and C3434.
23	(E7)	Connect oscilloscope to TP3408. Nixie selectors set at 02.2500 mc. Receiver tuned to 2.25 mc; system in sync; TUNE-SYNC-OPERATE switch in OPERATE.		If indication is normal, proceed to step 24. If indication is abnormal, first check J3407 to determine if a 3.25-4.25-mc signal exists there. If so, check T3406.
24	(E8)	Connect oscilloscope to TP3407.		If indication is normal, proceed to step 28. If indication is normal, yet no VARICAP or audio sync-tone exists, proceed to step 25. If indication is abnormal, check V3406 and associated tuned circuits.
25	(E9)	Connect oscilloscope to TP3409 and adjust scope for .1 usec/cm. Set synthesizer to 02.2500 mc. Place TUNE-SYNC-OPERATE switch in OPERATE.		If indication is normal, proceed to step 28. If indication is abnormal, check V3405, CR3408, CR3411, R3442, and associated circuitry. If indication is normal, yet no VARICAP output exists, see step 26. If no audio sync tone, see step 27.
26	(E10)	Connect oscilloscope to VARICAP d-c output jack J3008. Set synthesizer to 02.2500 mc. Place TUNE-SYNC-OPERATE switch in OPERATE. Move TUNE control in both directions.	 The reference should shift before system drops out of sync.	If indication is normal, proceed to step 28. If indication is abnormal, check R3443, R3445, C3437, C3438, J3405, P3017, J3008 and associated cabling.
27	(E11)	Connect oscilloscope to audio sync tone output J3014 and adjust scope for 2 ms/cm.		If indication is normal, proceed to step 28.

TABLE 5-6. FUNCTIONAL SECTION TROUBLESHOOTING CHART (CONT'D)

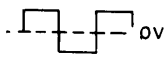

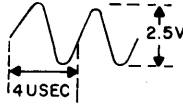
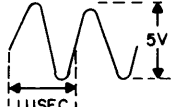
STEP	POINT	PRELIMINARY ACTION	NORMAL INDICATION	NEXT STEP
27 (cont.)		Set up synthesizer as in step 26, above. Place TUNE-SYNC-OPERATE switch to SYNC. With this switch in OPERATE, dc reference will be +3 volts instead of 0 volts.	 <p>As TUNE control is varied to get a zero beat, frequency decreases.</p>	If indication is abnormal, check R3444, C3439, J3406, P3016, J3014, and associated cabling and circuitry.
28	6	Connect oscilloscope to 2-mc output jacks J3010 through J3013. Adjust scope for .1 usec/cm.	 <p>Signal should have unequal peaks on upper trace and nearly equal lower peaks. Adjust T3503 for proper indication if necessary.</p>	<p>If indication is normal, proceed to step 29.</p> <p>If indication is abnormal, first check J3019 to see if a 5 volt peak-to-peak, 1-mc source exists there.</p> <p>If indication is still abnormal, check T3505, V3501, T3503, J3505, P3008.</p> <p>If indication is abnormal at any of the four 250-kc output jacks, check individual jack.</p>
29	7	Connect VTVM at TP3507 and measure r-f voltage. Set synthesizer to 2.25 mc. Place TUNE-SYNC-OPERATE in OPERATE.	VTVM indicates 0.24 volts rms.	<p>If indication is normal, proceed to step 28.</p> <p>If indication is abnormal, proceed to step 30.</p>
30	F1	Connect VTVM at TP3501 and measure signal.	VTVM indicates 0.14 volts rms.	<p>If indication is normal, proceed to step 33.</p> <p>If indication is abnormal, check V3505. If still abnormal, proceed to step 31.</p>
31	F2	Connect VTVM to HFO in jack J3009 and measure voltage.	VTVM indicates 20 to 50 mv (rms)	If indication is normal, check HFO input from HFR-1.
32	F3	Connect VTVM to TP3504 and measure voltage.	VTVM indicates 0.1 volt rms.	<p>If indication is normal, proceed to step 33.</p> <p>If indication is abnormal, check V3503, Z3502, V3506, V3504, V3502, and associated tuned circuits.</p>
33	F4	Connect VTVM to TP3502 and measure voltage.	VTVM indicates 0.22 volts rms.	If indication is normal, proceed to step 34.

TABLE 5-6. FUNCTIONAL SECTION TROUBLESHOOTING CHART (CONT'D)

STEP	POINT	PRELIMINARY ACTION	NORMAL INDICATION	NEXT STEP
33 (cont.)				If indication is abnormal, check V3507, T3502, and associated circuitry.
34	F5	Connect VTVM to TP3503 and measure voltage.	VTVM indicates 0.5 volts rms.	If indication is normal, proceed to step 35. If indication is abnormal, check V3509 and associated circuitry.
35	F6	Connect VTVM to TP3505.	VTVM indicates 0.17 volts rms.	If indication is normal, proceed to step 36. If indication is abnormal, check V3508 and associated circuitry.
36	F7	Connect VTVM to TP3506.	VTVM indicates 0.95 volts rms.	If indication is normal, proceed to step 37. If indication is abnormal, check V3510 and its associated circuitry.
37	F8	Connect VTVM to TP3507.	VTVM indicates 0.24 volts rms.	If indication is normal, proceed to step 38. If indication is abnormal, check V3511, V3512, and associated circuitry.
38	8	Connect oscilloscope to 250-kc output jacks J3015 through J3018 and determine signal at each jack.		If indication is abnormal, proceed to step 39.
39	G1	Connect oscilloscope to P3020 and adjust scope for .5 usec/cm.		If indication is normal, proceed to step 40. If indication is abnormal, check 1-mc source in 3100 deck and cabling.
40	G2	Connect VTVM to TP3701 and measure voltage.	VTVM indicates 20 volts rms.	If indication is normal, proceed to step 41. If indication is abnormal, check J3701, T3701, C3701, R3701, R3703.
41	G3	Connect VTVM to TP3702 and measure voltage.	VTVM indicates 0.74 volts rms.	If indication is normal, yet no output at any of jacks (J3015-J3018), check J3702, P3021, and cabling. If indication is abnormal, check V3701, V3702, V3703, and associated circuitry.

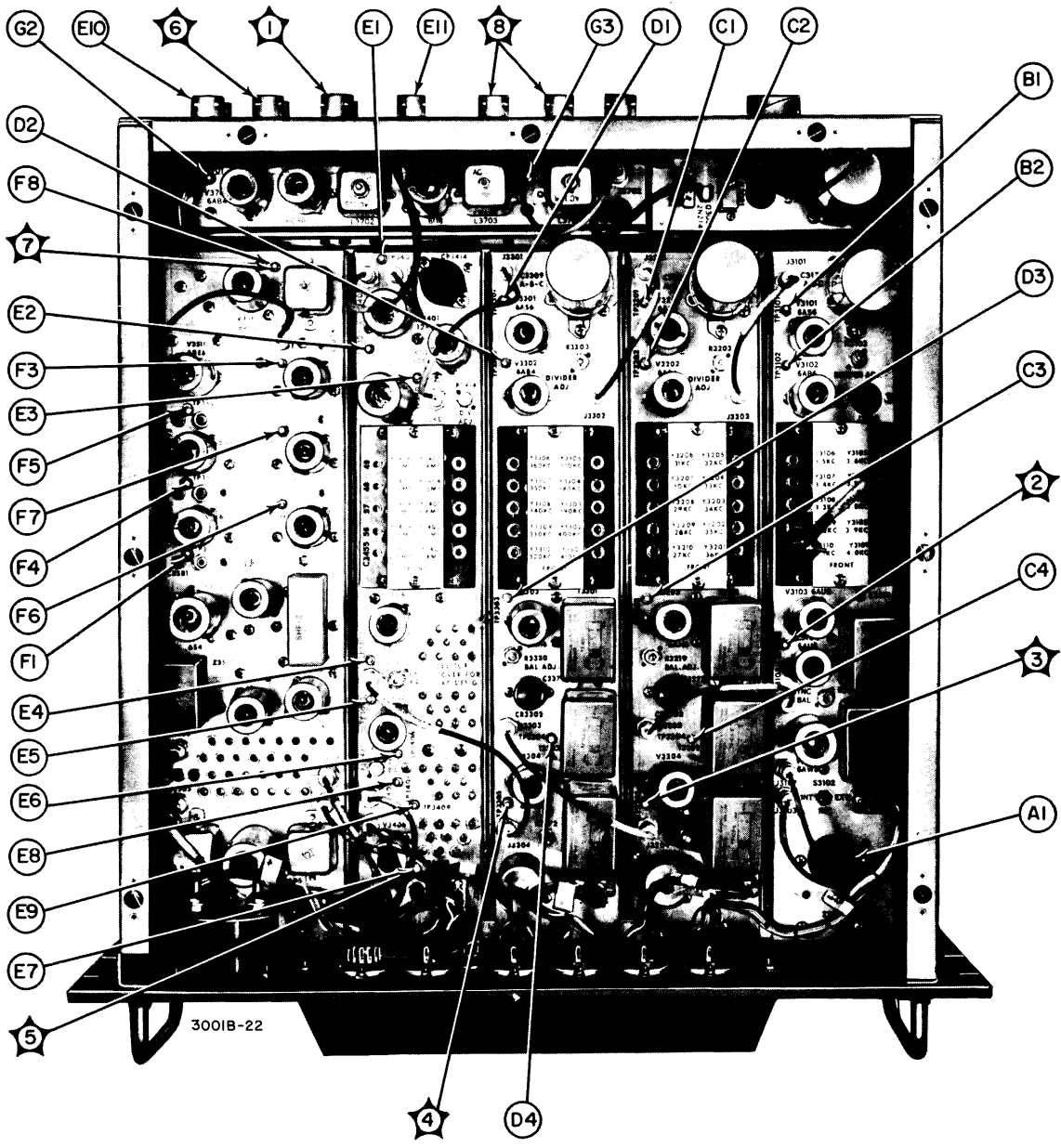


Figure 5-1. HFS-1, Top View Showing Test Points

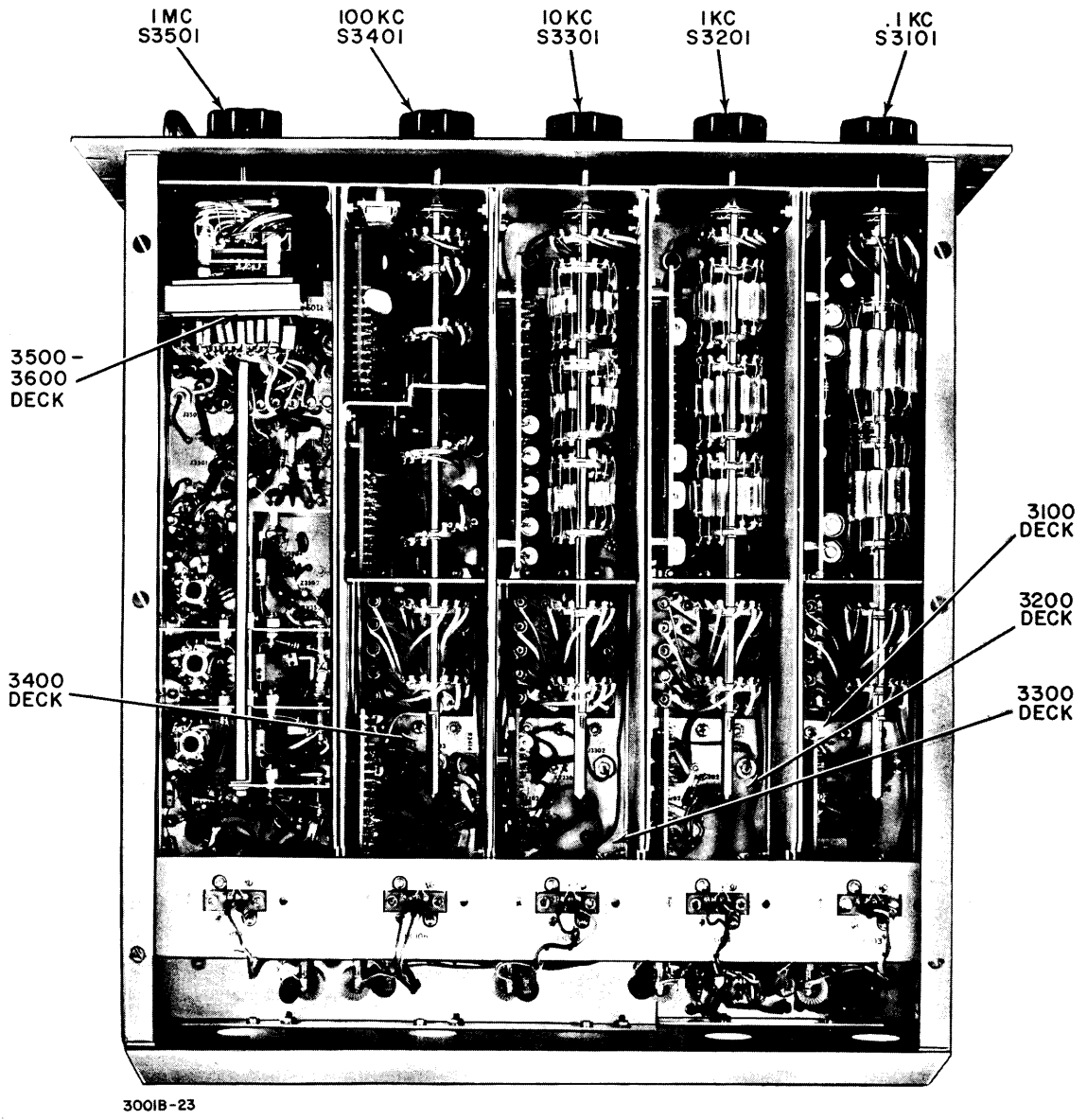


Figure 5-2. HFS-1, Bottom View Showing Decks

629.14-18

SECTION 6 MAINTENANCE

6-1. INTRODUCTION.

Maintenance may be divided into three categories: operator's maintenance, preventive maintenance, and corrective maintenance. The operator's maintenance, normally the maintenance carried out by the operator as he works with the equipment, is in Section 3 of this manual. Preventive and corrective maintenance procedures are given in this section.

The HFS-1 has been designed to provide long-term, trouble-free operation under continuous duty conditions. It is recommended that any necessary maintenance be done by a competent maintenance technician familiar with troubleshooting techniques. If the trouble cannot be corrected by following the procedures in this section and section 5, it is recommended that the HFS-1 be returned to the Technical Materiel Corporation for servicing.

6-2. PREVENTIVE MAINTENANCE.

In order to prevent failure of the equipment due to corrosion, tube failure, dust, or other destructive elements, it is suggested that a schedule of preventive maintenance be set up and adhered to. At periodic intervals (at least every six months) the equipment should be removed from the rack for cleaning and inspection. All accessible covers should

be removed and the wiring and all components inspected for dirt, corrosion, charring, discoloring, or grease. Dust may be removed with a soft brush. Remove dirt or grease from electrical parts with trichlorethylene. Remove dirt or grease from other parts with any good dry cleaning fluid.

WARNING

When using carbon trichlorethylene, make certain that adequate ventilation exists. Avoid prolonged contact with skin.

The preliminary inspection procedure, as outlined in table 5-2 can be used as a guide to preventive maintenance.

6-3. CORRECTIVE MAINTENANCE.

a. GENERAL. The corrective maintenance procedures are essentially Technical Materiel Corporation's factory alignment procedures modified for use in the field. Alignment procedures for the various functional sections are given in paragraphs 6-4 through 6-9.

b. TEST EQUIPMENT AND TOOLS. Table 6-1 lists the test equipment and tools necessary for alignment.

TABLE 6-1. TEST EQUIPMENT AND TOOLS

EQUIPMENT OR TOOL	MODEL
RF signal generator	Measurements Corp., Model 82 or equivalent
Frequency counter	Hewlett-Packard, Model 424C or equivalent
Oscilloscope	Tektronics Type 545A or equivalent
RF Vtvm	Ballantine 314 or equivalent
50-ohm, 1/2 watt, resistor with miniature RG-174/U cable and TMC-PL-204 Plug	
JFD Tool No. 5824 3/16 hollow spintite with concentric screwdriver	
5/16 hollow spintite to receive concentric screwdriver	

c. PRELIMINARY ALIGNMENT PROCEDURES. Before attempting any alignment procedures, make sure that the following steps are performed.

(1) Unit is completely installed and all cables and interconnections are made.

(2) The receiver must have had a least six hours warm-up in a STANDBY condition prior to alignment.

(3) The voltage at TP8001 and TP8002 on the power supplies must read exactly 200 volts dc. If it is not, adjust regulator potentiometers R8014 and R8025 as necessary.

(4) Connect an oscilloscope to 1 mc int. std. jack J3019 at rear of HFS-1. Scope should indicate a "clean" 1-mc signal with a peak-to-peak voltage of 5 volts. If any abnormal indication is present, refer to section 5 of this manual before continuing.

(5) Connect an oscilloscope to TP3401 and check waveform. See step 17 in table 5-4 for correct waveform.

(6) Connect an oscilloscope to TP3402 and check waveform. See step 18 in table 5-4 for correct waveform.

(7) Connect an oscilloscope to TP3403 and check waveform. See step 19 in table 5-4 for correct waveform. If abnormal indication exists, unlock R3411 and adjust it until proper waveform exists.

(8) Connect oscilloscope to TP3301 and check waveform. See step 12 in table 5-4.

(9) Connect oscilloscope to TP3302 and check waveform. See step 13 in table 5-4. If abnormal indication exists, unlock and readjust R3303 until proper waveform is indicated.

(10) Connect oscilloscope to TP3201 and check waveform. See step 7 in table 5-4.

(11) Connect oscilloscope to TP3202 and check waveform. See step 8 in table 5-4. If abnormal indication is present, unlock and adjust R3203 until proper waveform exists.

(12) Connect oscilloscope to TP3101 and check waveform. See step 4 in table 5-4.

(13) Connect oscilloscope to TP3102 and check waveform. See step 5 in table 5-4. If abnormal indication is present, unlock and adjust R3104 until proper waveform exists.

NOTE

The alignment of the 3500 deck should be undertaken before the alignment of the 3400 deck in order to simplify overall procedures.

6-4. ALIGNMENT OF 3100 DECK.

a. Disconnect P3105 from J3105 and insert indicator tube plug into J3105. Also connect a 56-ohm resistor (1/2 watt) load at J3102. Connect oscilloscope across J3102.

b. Set .1 KC switch so indicator tube reads "0." With the alignment tool, adjust C3128. The waveform should be a "clean" 4-kc signal with a peak-to-peak amplitude between 0.5 and 0.8 volts.

c. Set the .1 KC switch to the indicator position listed in table 6-2 below and adjust the particular capacitor to its corresponding frequency. The oscilloscope should indicate signals between 0.5 and 0.8 volts at each frequency.

TABLE 6-2. CAPACITORS TO BE ALIGNED

NIXIE INDICATION	CAPACITOR	FREQUENCY (KC)
1	C3129	3.9
2	C3130	3.8
3	C3131	3.7
4	C3132	3.6
5	C3133	3.3
6	C3134	3.4
7	C3135	3.3
8	C3136	3.2
9	C3137	3.1

d. Remove dummy load and reconnect P3102 to J3102.

6-5. ALIGNMENT OF 3200 DECK

a. Connect the oscilloscope to TP3203. Set 1 KC nixie selector switch to "0."

b. Adjust C3232 and C3272 for a maximum indication of TP3203.

c. Set the 1 KC switch to the positions indicated in table 6-3 below and adjust corresponding capacitors for a maximum indication at TP3203.

TABLE 6-3. CAPACITORS TO BE ALIGNED

NIXIE INDICATION	CAPACITOR	FREQUENCY (KC)
1	C3233	35
2	C3234	34
3	C3235	33
4	C3236	32
5	C3237	31
6	C3238	30
7	C3239	29
8	C3240	28
9	C3241	27

d. Set the 1 KC selector to "0." Then run the selector through all positions, observing the amplitude of the waveform at TP3203. Adjust C3272 to maintain the amplitudes of the signals within ± 1.5 db of each other.

e. Remove P3103 from J3203 and connect oscilloscope to J3203. Adjust balance adjust control R3219 for a minimum indication on the oscilloscope. Then reconnect P3103 to J3203.

f. Set the .1 KC selector on the 3100 deck to "8" (3.2 kc) and the 1 KC selector to "0" (38 kc). Connect the oscilloscope to TP3204 and adjust C3273 for a maximum indication of TP3204.

g. Rotate the 1 KC selector through positions "1" through "9" and observe the signal amplitude on the oscilloscope at each position. If necessary, readjust C3273 to maintain the amplitudes within ± 1.5 db of each other.

h. Connect the oscilloscope to TP3205. Set the .1 KC selector to "1" (3.9 kc) and 1 KC selector to "0" (36 kc). Adjust C3274 for a maximum indication at TP3205.

i. Rotate the 1 KC selector through positions "1" through "9" and observe the signal amplitude on the oscilloscope at each position. If necessary, readjust C3274 to assure that the amplitudes remain within ± 1.5 db of each other.

j. Remove P3204 from J3204. Connect the 50-ohm dummy load to J3204 and connect the oscilloscope across the dummy load.

k. Set the 1 KC selector to "0" and the .1 KC selector to "9." Rotate the .1 KC selector through all positions. The output voltage should be at least 0.56 volts peak-to-peak.

l. Set the 1 KC selector to "0" and the .1 KC selector to "9." Rotate the 1 KC to all positions.

The output voltage should be at least 0.56 volts peak-to-peak.

m. Remove the oscilloscope and dummy load from J3204. Reconnect P3204 and J3204.

6-6. ALIGNMENT OF 3300 DECK.

a. Connect the oscilloscope to TP3303. Set the 10 KC selector to "0" (410 kc).

b. Adjust C3328 and then C3370 for a maximum indication at TP3303. Then set the 10 KC selector to the positions indicated in table 6-4, below, and adjust corresponding capacitors for a maximum indication at TP3303.

TABLE 6-4. CAPACITORS TO BE ALIGNED

NIXIE INDICATION	CAPACITOR	FREQUENCY (KC)
1	C3329	400
2	C3330	390
3	C3331	380
4	C3332	370
5	C3333	360
6	C3334	350
7	C3335	340
8	C3336	330
9	C3337	320

c. Move the 10 KC selector through positions "9" through "0" again, observing the indications at TP3303. If necessary, adjust C3370 to maintain the amplitudes within 3 db of each other.

d. Disconnect P3203 from J3303 and connect oscilloscope to J3303. Adjust R3330 for a minimum indication on the oscilloscope. Then remove oscilloscope and reconnect P3203 to J3303.

e. Set the .1 KC switch to "0" (4 kc), the 1 KC switch to "9" (27 kc), and the 10 KC switch to "9" (310 kc). These settings correspond to a frequency of 351 kc.

f. Connect the oscilloscope to TP3304 and adjust C3371 for a maximum indication.

g. Move the 10 KC selector through the remaining nine positions, observing the amplitudes of the signals at TP3304. If necessary, readjust C3371 to maintain the amplitudes within 3 db of each other.

h. Connect the oscilloscope to TP3305. Set the .1 KC selector to "0" (4 kc), the 1 KC selector to "1" (35 kc), and the 10 kc to "0" (410 kc). These settings correspond to a frequency of 449 kc.

i. Adjust C3372 for a maximum indication with the oscilloscope at TP3305.

j. Move the 10 KC selector through the remaining nine positions, observing the signal at TP3305. If necessary, readjust C3372 to maintain the signal amplitudes within 3 db of each other.

k. Disconnect P3304 from J3304 and connect the 50-ohm load to J3304. Connect the oscilloscope across the load.

l. Set the .1 KC selector to "0" (4 kc), the 1 KC selector to "0" (36 kc), and 10 KC selector to "0" (410 kc). This corresponds to a frequency of 450 kc.

m. While observing the indication on the oscilloscope, rotate the .1 KC selector through all its positions to "9." Then rotate the 1 KC selector through all its positions to "9." The signal amplitude at each position should be 0.56 volts peak-to-peak.

n. Place the 10 KC selector in position "1." Then, like in step m, above, while observing the indication on the oscilloscope, rotate the .1 KC selector through all its positions to "9." Then rotate the 1 KC selector through all its positions to "9." The signal amplitude should be 0.56 volts peak-to-peak.

o. Move the 10 KC selector to position "2." Repeat step m, above, with the 10-kc selector in this position.

p. Continue this procedure for the remaining positions of the 10 KC selector.

q. Remove oscilloscope, dummy load, and reconnect P3304 to J3304.

6-7. ALIGNMENT OF 3500 DECK.

a. GENERAL.

(1) Disconnect P301 from J3503. This removes the HFO input from the tuner. Set MC selector to a blank position.

(2) Disconnect P3014 from J3501. This removes the 1-mc input to the 3500 deck.

b. 40.5-MC IF AMPLIFIER CHAIN.

(1) Connect an RF generator to TP3509 and set the generator frequency to 40.5-mc. Reduce the signal generator output to a minimum required for an adequate indication to prevent overloading and oscillation.

(2) Connect an oscilloscope to TP3504 and adjust C3623 for a maximum indication.

(3) Connect the oscilloscope to TP3505 and adjust C3628 for a maximum indication.

(4) Connect the oscilloscope to TP3506 and adjust C3634 for a maximum indication.

(5) Connect the frequency counter to TP3506. Counter should read 40.5 mc \pm 3 kc. Then remove the signal generator and counter. (This "strip" will be "peaked" again after alignment of the 3400 deck.)

c. ALIGNMENT OF MC SELECTOR (See figure 6-1.)

(1) Connect an RF VTVM at pin 6 of V3505.

(2) Set the MC selector to the positions indicated in table 6-5, below, and adjust corresponding capacitor for a maximum indication.

TABLE 6-5. CAPACITORS TO BE ALIGNED

NIXIE INDICATION	CAPACITOR	FREQUENCY (KC)
3	C3502	49.5
4	C3503	50.5
5	C3504	51.5
6	C3505	52.5
7	C3506	53.5
8	C3507	54.5
9	C3508	55.5
10	C3509	56.5
11	C3510	57.5
12	C3511	58.5
13	C3512	59.5
14	C3513	60.5
15	C3514	61.5
16	C3515	62.5
17	C3516	63.5
18	C3517	64.5
19	C3518	65.5
20	C3519	66.5
21	C3520	67.5
22	C3521	68.5
23	C3522	69.5

**TABLE 6-5. CAPACITORS TO BE ALIGNED
(CONT'D)**

NIXIE INDICATION	CAPACITOR	FREQUENCY (KC)
24	C3523	70.5
25	C3524	71.5
26	C3525	72.5
27	C3526	73.5
28	C3527	74.5
29	C3528	75.5
30	C3529	76.5
31	C3530	77.5

d. ALIGNMENT OF 43.75 - 44.75-MC AMPLIFIER.

(1) Connect an RF generator at TP3508 and set the frequency to 44.25 mc (the amplifier mean frequency). Maintain the generator output of the minimum required for an indication of tuning during subsequent steps. Set the 1 MC nixie selector to a blank position.

(2) Connect a VTVM to TP3501 and adjust C3581 for a maximum indication. Reduce the signal output to zero. The VTVM should indicate zero; if it does not, the stage is oscillating. Repeat this step at another point in the circuit until an indication can be obtained which follows the signal generator output amplitude. Then adjust C3582 for a minimum indication.

(3) Connect the RF VTVM to TP3502 and adjust C3588 for a maximum indication and C3590 for a minimum indication.

(4) Connect the RF VTVM to TP3503 and adjust C3593 for a maximum indication. Then remove VTVM.

(5) Reconnect P3011 to J3503 and P3014 to J3501. Connect the frequency counter to TP3503. Remove signal generator.

(6) Tune the RF tuner to any even mc; for example, 2.0 mc. Set up the nixie selectors to the same frequency: 02000000.

(7) The counter should read in the vicinity of 44.75 mc. Tune the RF tuner to 2.99 mc and the synthesizer to 02.990000. The counter should now read in the vicinity of 43.75 mc.

e. ALIGNMENT OF T3504 AND T3406 (3400, 3500 DECK).

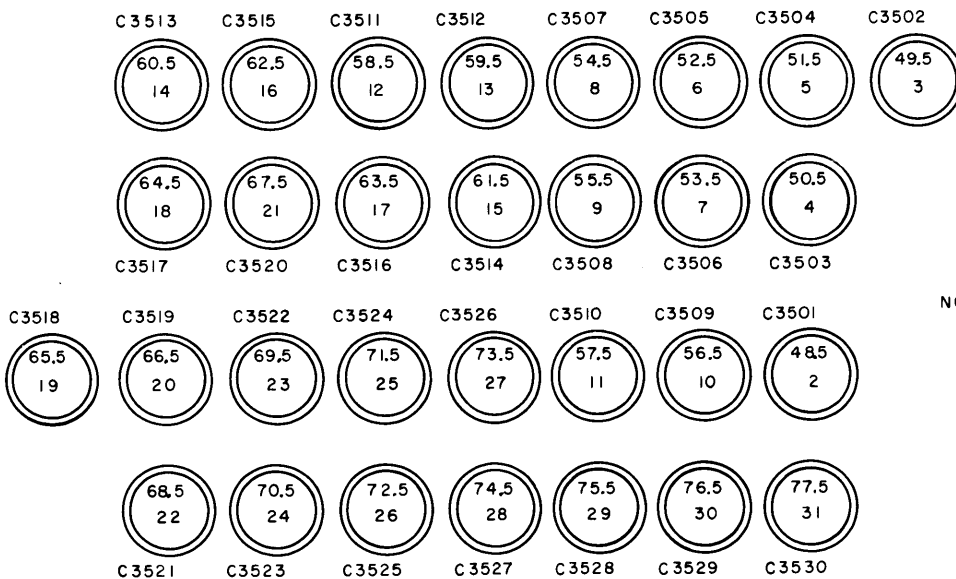
(1) Connect a VTVM to TP3507.

(2) Set the nixie selectors to 02.000000 and the RF tuner to 2.5 mc.

(3) Adjust T3504 for a maximum indication.

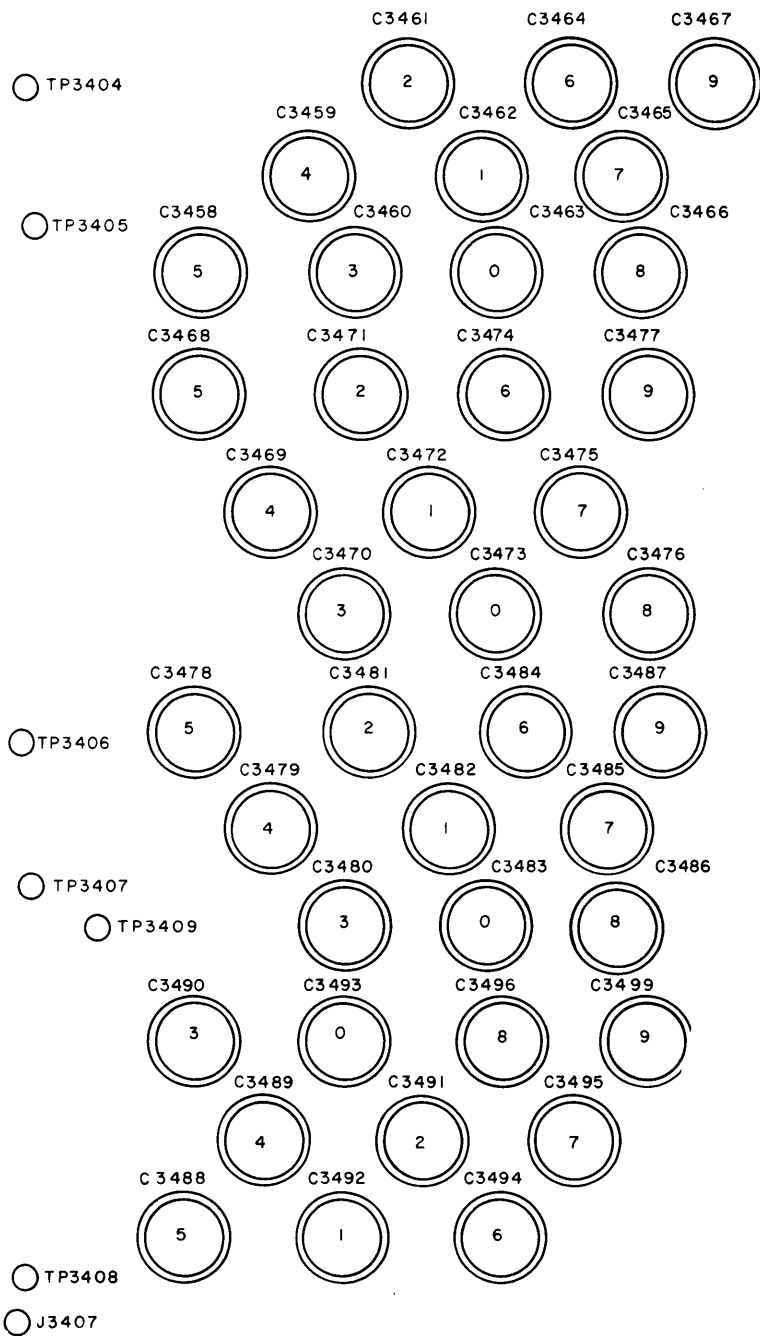
(4) Connect VTVM to TP3408 and adjust T3406 for maximum indication.

(5) Rotate the TUNE control between 2.0 and 2.99 mc. The indication should be constant, with a peak at 2.5 mc. If the drop-off at the ends is extreme, T3504 and T3405 may be adjusted to emphasize either the "highs" or "lows."



NOTE
UNIT VIEWED FROM TOP FRONT. UPPER NUMERAL ON EACH CAPACITOR IDENTIFIES CRYSTAL FREQUENCY WHILE LOWER NUMERAL ON EACH CAPACITOR IDENTIFIES THE NIXIE INDICATOR POSITION.

Figure 6-1. Identification of Piston Capacitors on 3500 Deck



NOTE
 UNITS VIEWED FROM TOP FRONT.
 NUMERAL IN CENTER INDICATES NIXIE
 INDICATION AT WHICH CAPACITOR IS
 ALIGNED.

Figure 6-2. Identification of Piston Capacitors on 3400 Deck

f. ALIGNMENT OF 1 AND 2-MC CIRCUITS.

(1) Connect an oscilloscope to rear panel jack J3010, J3011, J3012, or J3013. Adjust T3505 for a maximum indication.

(2) Connect the oscilloscope to 2-mc output jacks J3010, J3011, J3012, or J3013. Adjust T3503 for a maximum indication. Note the waveform and compare it with the 2-mc signal shown in step 38, table 5-4. Then remove the oscilloscope.

6-8. ALIGNMENT OF 3400 DECK.(See figure 6-2.)

a. Connect oscilloscope to TP3404. Place the 100 KC nixie selector in the "0" position. Adjust C3454 and C3463 for a maximum indication.

b. Set the 100-kc nixie selector to the positions listed below in table 6-6 and adjust the corresponding capacitors for maximum indication on the oscilloscope.

TABLE 6-6. CAPACITORS TO BE ALIGNED

NIXIE INDICATION	CAPACITOR	FREQUENCY (MC)
1	C3453 C3462	3.7
2	C3452 C3461	3.6
3	C3451 C3460	3.5
4	C3450 C3459	3.4
5	C3449 C3458	3.3
6	C3448 C3464	3.2
7	C3457 C3465	3.1
8	C3456 C3466	3.0
9	C3455 C3467	2.9

c. Remove P3303 from J3404. Connect the oscilloscope to J3404. Adjust R3432 for MINIMUM indication on the oscilloscope. Then remove oscilloscope and reconnect P3303 and J3404.

d. Connect the oscilloscope to TP3405. Set the .1 KC selector to "0" (4 kc); the 1 KC selector to "0" (36 kc) the 10 KC selector to "9" (320 kc); and the 100 KC selector to "0" (3.8 mc). This corresponds to a frequency of 4.16 mc.

e. Locate CR3413 on the terminal board beneath the 3400 deck and ground its anode. This disables the AGC loop to obtain an indication of tuning.

f. Adjust C3473 for a maximum indication on the oscilloscope.

g. Set the 100 KC nixie selector to the positions listed below in table 6-7 and adjust the corresponding capacitors for maximum indication on the oscilloscope.

TABLE 6-7. CAPACITORS TO BE ALIGNED

NIXIE INDICATION	CAPACITORS	FREQUENCY (MC)
1	C3472	4.06
2	C3471	3.96
3	C3470	3.86
4	C3469	3.76
5	C3468	3.66
6	C3474	3.56
7	C3475	3.46
8	C3476	3.36
9	C3477	3.26

h. Connect the oscilloscope to TP3406. Set the .1 KC selector to "0" (4 kc); the 1 KC selector to "0" (36 kc); the 10 KC selector to "1" (400 kc); and 100 KC selector to "0" (3.8 mc). This corresponds to a frequency of 4.24 mc. Adjust C3483 for a maximum indication.

i. Turn the 100 KC selector to "1" (4.14 mc) and adjust C3482 for a maximum indication.

j. Advance the 100 KC selector to the positions indicated below in table 6-8 and adjust the corresponding capacitors for a maximum indication on the oscilloscope.

TABLE 6-8. CAPACITORS TO BE ALIGNED

NIXIE INDICATION	CAPACITORS	FREQUENCY (MC)
2	C3481	4.04
3	C3480	3.94
4	C3479	3.84
5	C3478	3.74
6	C3484	3.64
7	C3485	3.54
8	C3486	3.44
9	C3487	3.34

k. Remove the ground from the anode of CR3413. Leave the scope probe at TP3406. Set the 100 KC, 10 KC, 1 KC, and .1 KC selectors to "0."

l. While observing the oscilloscope, advance the 10 KC, 1 KC and .1 KC selectors, in succession, to "9." The amplitude should not change more than 3 db.

m. Advance the 100 KC selector to "1." Then retard in succession the 10 KC, 1 KC, and .1 KC selectors to "0." The amplitude should not change more than 3 db.

n. Advance the 100 KC selector to "2." Then advance in succession the 10 KC, 1 KC, and .1 KC selectors to "9." The amplitude should not change more than 3 db.

o. Advance the 100 KC selector to "3." Then retard in succession the 10 KC, 1 KC, and .1 KC selectors to "8." The amplitude should not change more than 3 db.

p. Continue this procedure for the remaining positions ("4" to "9") of the 100 KC selector.

q. Alignment of the 4.25 to 3.25-mc amplifier.

(1) Set the 100 KC selector to "0," the 1 MC selector to "02."

(2) On the RF tuner, set the BAND and TUNE controls for a frequency of 2.05 mc. This corresponds to a synthesizer frequency of 4.2 mc from the 3500 deck into J3407.

(3) Connect a VTVM to TP3407 and adjust C3493 for a maximum indication.

(4) Carefully rock the TUNE control ± 50 kc around 2.05 mc. The amplitude at TP3407 should remain within 3 db.

(5) Repeat this procedure for the remaining positions of the 100 KC selector. Set the 100 KC selector to the positions indicated below in table 6-9 and adjust the corresponding capacitors for maximum indication on the oscilloscope.

6-9. ALIGNMENT OF 3700 DECK.

a. Connect a 56-ohm resistor (1/2 watt) across J3702. Connect oscilloscope to pin 1 of V3703.

b. Connect a signal generator to pin 9 of V3703. Set frequency of generator to 750-kc at an amplitude of 0.2 volts rms.

c. Tune L3702 for a maximum output (approximately 1.8 volts peak-to-peak) on the scope.

d. Connect the signal generator to J3701 and tune it to an output frequency of 250-kc at an amplitude of 50 millivolts (rms).

e. Tune L3701 for a maximum output (approximately 3.3 volts peak-to-peak) on the scope.

f. Retune the signal generator to 1-mc at an amplitude of 3 volts rms (as measured at TP3701). Connect oscilloscope to TP3702.

g. Tune L3703 for maximum output (approximately 3.5 volts peak-to-peak) on the scope.

h. Retune L3701, L3702, and L3703 and lock tuning adjustments carefully.

i. Measure output voltage. It should be between 1 and 1.5 volts rms at J3702.

TABLE 6-9. CAPACITORS TO BE ALIGNED

NIXIE INDICATION	CAPACITORS	RF TUNER FREQUENCY (MC)	SYNTHESIZER FREQUENCY (MC)
1	C3492	2.15	4.1
2	C3491	2.25	4.0
3	C3490	2.35	3.9
4	C3489	2.45	3.8
5	C3488	2.55	3.6
6	C3494	2.65	3.6
7	C3495	2.75	3.5
8	C3496	2.85	3.4
9	C3497	2.95	3.3

SECTION 7 PARTS LIST

7-1. INTRODUCTION.

The parts list presented in this section is a cross-reference list of parts identified by a reference designation and TMC part number. In most cases, parts appearing on schematic diagrams are assigned reference designations in accordance with MIL-STD-16. Wherever practicable, the reference designation is marked on the equipment, close to the part it identifies. In most cases, mechanical and electro-mechanical parts have TMC part numbers stamped on them.

To expedite delivery when ordering any part, specify the following:

- a. Generic name.

- b. Reference designation.
- c. TMC part number.
- d. Model and serial numbers of the equipment containing the part being replaced, this can be obtained from the equipment name-plate.

For replacement parts not covered by warranty (refer to warranty sheet in front of manual), address all purchase orders to:

The Technical Materiel Corporation
Attention: Sales Department
700 Fenimore Road
Mamaroneck, New York

<u>Assembly or Sub-assembly</u>	<u>Page</u>
Front Panel and Main Frame Assembly (Symbol Series 3000)	7-1
100 Cycle Selector Deck (Symbol Series 3100)	7-4
1 Kc Selector Deck (Symbol Series 3200)	7-12
10 Kc Selector Deck (Symbol Series 3300)	7-19
100 Kc Selector Deck (Symbol Series 3400/3800)	7-27
1 Mc Selector Deck (Symbol Series 3500/3600)	7-35
Regenerative Divider (Symbol Series 3700)	7-47

FRONT PANEL AND MAIN FRAME ASSEMBLY

REF SYMBOL	DESCRIPTION	TMC PART NUMBER
AT3000	DUMMY LOAD, ELECTRICAL: 47 ohms, $\pm 10\%$; 1/2 watt; BNC connector type; 3-1/2" chain.	DL100-4
AT3001	Same as AT3000.	
C3001	CAPACITOR, FIXED, ELECTROLYTIC: triple section; 20 uf each section; 450 VDCW; polarized; tubular case; plug-in type.	CE-108-1
C3002	CAPACITOR, FIXED, CERAMIC DIELECTRIC: 10,000 uuf; GMV 500 VDCW.	CC-100-16
C3003 thru C3011	Same as C3002.	
C3012	CAPACITOR, FIXED, CERAMIC DIELECTRIC: 100,000 uuf, $+80\% -20\%$; 500 WVDC.	CC-100-32
C3013	CAPACITOR, FIXED, CERAMIC DIELECTRIC: 100,000 uuf, $+80\% -20\%$; 100 VDCW.	CC-100-28
DS3001	INDICATOR, DIGITAL DISPLAY: ionization voltage, 170 VDC min; anode current 4.0 ma individual cathode wattage, 0.4 watts max; plug-in type; 13 pins.	BI-109-2
DS3002	Same as DS3001.	

PARTS LIST (CONT'D)

FRONT PANEL AND MAIN FRAME ASSEMBLY

REF SYMBOL	DESCRIPTION	TMC PART NUMBER
DS3003	LAMP, GLOW: 110/125 v, 1/15 watts; midget flange base; T-2 bulb.	BI-111-1
DS3004 thru DS3007	Same as DS3001.	
J3001	CONNECTOR, RECEPTACLE, ELECTRICAL: 14 #16 contacts, rated at 17.0 amperes.	JJ-200-2
J3002	CONNECTOR, RECEPTACLE, ELECTRICAL: 11 round #20 female contacts, straight type.	JJ-242-1S
J3003	CONNECTOR, RECEPTACLE, ELECTRICAL: 7 round #16 female contacts, straight type.	JJ-216
J3004 thru J3007	Same as J3003.	
J3008	CONNECTOR, RECEPTACLE, ELECTRICAL: RF type; 1 round female contact; straight type; series BNC to BNC.	UG-625/U
J3009 thru J3021	Same as J3008.	
K3001	RELAY, ARMATURE: coil operating voltage 26.5 VDC, coil resistance, 1825 ohms dc; current rating low level; double pole, double throw, min. operating amps .012.	RL-143-2
L3001	COIL, RADIO FREQUENCY: fixed; 50,000 uuf, $\pm 5\%$; 110 ohms dc resistance, 75 ma current.	CL-226-5
L3002 thru L3005	Same as L3001.	
M3001	METER, ARBITRARY SCALE: movement 0-50 microamps; approximate resistance 2000 ohms $\pm 5\%$; black scale on white background; rectangular case.	MR-162
P3001	CONNECTOR, PLUG, ELECTRICAL: 11 round #20 contacts; straight type; with hood.	PL-225-3P
P3002 thru P3006	Same as P3001.	
P3007	CONNECTOR, PLUG, ELECTRICAL: two flat male contacts; polarized; with cable clamp; straight type.	PL-105-1

PARTS LIST (CONT'D)

FRONT PANEL AND MAIN FRAME ASSEMBLY

REF SYMBOL	DESCRIPTION	TMC PART NUMBER
P3008	CONNECTOR, PLUG, ELECTRICAL: 1 round female coaxial contact; straight type.	PL-204
P3009 thru P3021	Same as P3008.	
Q3001	NOT USED	
Q3002	TRANSISTOR: NPN; silicon mesa; collector to base voltage 60 V; collector to emitter voltage 40 V; emitter to base voltage 5 V; collector current 175 ma; power dissipation 2 watts at 25°C; junction temperature 175°C; hermetically sealed metal case.	2N697
R3001	RESISTOR, FIXED, COMPOSITION: 1000,000 ohms; ±10%, 1/2 watt.	RC20GF104K
R3002	RESISTOR, FIXED, COMPOSITION: 12 ohms; ±10%, 1/2 watt.	RC20GF120K
W3001	WIRING HARNESS: consists of 1 connector symbol P3001, 1 socket electron tube symbol XDS3001 and various lengths and colors of MIL type MWC wire.	CA-667
W3002	WIRING HARNESS: consists of 1 connector symbol P3002, 1 socket electron tube symbol XDS3002; and 6.75 in. of various colors of MIL type MWC wire.	CA-668
W3003	Same as W3002, uses 1 connector P3003, socket XDS3004.	
W3004	Same as W3002, uses 1 connector P3004, socket XDS3005.	
W3005	Same as W3002, uses 1 connector P3005, socket XDS3006.	
W3006	WIRING HARNESS: consists of 1 connector symbol P3006, 1 socket electron tube symbol XDS3007; and 11.75 in. of various colors of MIL type MWC wire.	CA-695
W3007	CABLE ASSEMBLY, RADIO FRE- QUENCY: consists of 7 inches of RF wire RG174/U; and 1 connector symbol P3021.	CA-480-71-7.00
W3008	CABLE ASSEMBLY, SPECIAL PURPOSE ELECTRICAL BRANCHED: consists of various lengths and colors of insulated standed MIL type MWC wire, various lengths of coaxial cable MIL type RG174/U, connectors symbols P3007 thru P3020.	CA-700

PARTS LIST (CONT'D)

FRONT PANEL AND MAIN FRAME ASSEMBLY

REF SYMBOL	DESCRIPTION	TMC PART NUMBER
XC3001 A, B, C	SOCKET, ELECTRON TUBE: octal type.	TS101P01
XDS3001	SOCKET, ELECTRON TUBE: 13 pin.	TS-157
XDS3002	Same as XDS3001.	
XDS3003	LAMPHOLDER: accommodates midget flange base T-2 type lamp; consists of holder, TMC no. TS-159, and lamp retaining bushing, TMC no. PO-230-1.	TS-156
XDS3004 thru XDS3007	Same as XDS3001.	
XQ3001	NOT USED	
XQ3002	SOCKET, TRANSISTOR: 4 silver plated beryllium copper w/gold clash contacts; molded mica filled phenolic.	TS-147

100 CYCLE SELECTOR DECK

C3101	CAPACITOR, FIXED, CERAMIC DIELECTRIC: 1000 uuf; $\pm 10\%$; 500 VDCW.	CC-100-9
C3102	CAPACITOR, FIXED, CERAMIC DIELECTRIC: 10,000 uuf; GMV: 500 VDCW.	CC-100-16
C3103	CAPACITOR, FIXED, MICA DIELECTRIC: 4700 uuf; $\pm 5\%$; 500 VDCW.	CM35B472J
C3104	CAPACITOR, FIXED, CERAMIC DIELECTRIC: 5000 uuf; GMV; 500 VDCW.	CC-100-15
C3105	CAPACITOR, FIXED, CERAMIC DIELECTRIC: 100,000 uuf, +80% -20%; 300 VDCW.	CC-100-37
C3106	Same as C3101.	
C3107	CAPACITOR, FIXED, MICA DIELECTRIC: 1000 uuf; $\pm 10\%$; 500 VDCW.	CM20B102K
C3108	CAPACITOR, FIXED, ELECTROLYTIC: 8 uf; 250 VDCW; polarized tubular metal case with plastic sleeve.	CE-116-1VN
C3109	CAPACITOR, FIXED, MICA DIELECTRIC: 100 uuf; $\pm 5\%$; 500 VDCW.	CM15B101J
C3110	Same as C3107.	
C3111	Same as C3108.	
C3112	Same as C3105.	
C3113	Same as C3108.	
C3114	Same as C3101.	

PARTS LIST (CONT'D)

100 CYCLE SELECTOR DECK

REF SYMBOL	DESCRIPTION	TMC PART NUMBER
C3115	Same as C3108.	
C3116	NOT USED	
C3117	CAPACITOR, FIXED PLASTIC DI-ELECTRIC: mylar, metallized; 0.10 uf; $\pm 20\%$; 400 VDCW.	CN114-R10-4M
C3118	NOT USED	
C3119	CAPACITOR, FIXED, CERAMIC DI-ELECTRIC: 20,000 uuf; +80% -20%; 500 VDCW.	CC-100-24
C3120	CAPACITOR, FIXED, CERAMIC DI-ELECTRIC: 5 uuf; $\pm 20\%$; 500 VDCW.	CM15B050M
C3121	Same as C3109.	
C3122	Same as C3119.	
C3123	NOT USED	
C3124	Same as C3102.	
C3125	CAPACITOR, FIXED, ELECTROLYTIC: triple section; 20 uf each section; 450 VDCW; polarized; tubular case; plug-in type.	CE-108-1
C3126	Same as C3119.	
C3127	Same as C3119.	
C3128	CAPACITOR, VARIABLE, GLASS DI-ELECTRIC: 1 to 30 uuf; 1000 VDCW.	CV-108-4
C3129 thru C3137	Same as C3128.	
C3138	CAPACITOR, FIXED, PLASTIC DI-ELECTRIC: 5400 uuf; $\pm 1\%$; 200 VDCW.	CX-104-55
C3139	CAPACITOR, FIXED, PLASTIC DI-ELECTRIC: 5000 uuf; $\pm 1\%$; 200 VDCW.	CX-104-54
C3140	CAPACITOR, FIXED, PLASTIC DI-ELECTRIC: 4500 uuf; $\pm 1\%$; 200 VDCW.	CX-104-53
C3141	CAPACITOR, FIXED, PLASTIC DI-ELECTRIC: 4250 uuf; $\pm 1\%$; 200 VDCW.	CX-104-52
C3142	CAPACITOR, FIXED, PLASTIC DI-ELECTRIC: 3750 uuf; $\pm 1\%$; 200 VDCW.	CX-104-51
C3143	CAPACITOR, FIXED, PLASTIC DI-ELECTRIC: 3500 uuf; $\pm 1\%$; 200 VDCW.	CX-104-50
C3144	CAPACITOR, FIXED, PLASTIC DI-ELECTRIC: 3300 uuf; $\pm 1\%$; 200 VDCW.	CX-104-49

PARTS LIST (CONT'D)

100 CYCLE SELECTOR DECK

REF SYMBOL	DESCRIPTION	TMC PART NUMBER
C3145	CAPACITOR, FIXED, PLASTIC DI-ELECTRIC: 3000 uuf; $\pm 1\%$; 200 VDCW.	CX-104-48
C3146	CAPACITOR, FIXED, PLASTIC DI-ELECTRIC: 2700 uuf; $\pm 1\%$; 200 VDCW.	CX-104-47
C3147	CAPACITOR, FIXED, PLASTIC DI-ELECTRIC: 53,000 uuf; $\pm 1\%$; 200 VDCW.	CX-104-56
C3148	CAPACITOR, FIXED, PLASTIC DI-ELECTRIC: 14,500 uuf; $\pm 1\%$; 200 VDCW.	CX-104-45
C3149	CAPACITOR, FIXED, PLASTIC DI-ELECTRIC: 13,900 uuf; $\pm 1\%$; 200 VDCW.	CX-104-44
C3150	CAPACITOR, FIXED, PLASTIC DI-ELECTRIC: 12,500 uuf; $\pm 1\%$; 200 VDCW.	CX-104-43
C3151	CAPACITOR, FIXED, PLASTIC DI-ELECTRIC: 11,100 uuf; $\pm 1\%$; 200 VDCW.	CX-104-42
C3152	CAPACITOR, FIXED, PLASTIC DI-ELECTRIC: 10,200 uuf; $\pm 1\%$; 200 VDCW.	CX-104-41
C3153	CAPACITOR, FIXED, PLASTIC DI-ELECTRIC: 9400 uuf; $\pm 1\%$; 200 VDCW.	CX-104-40
C3154	CAPACITOR, FIXED, PLASTIC DI-ELECTRIC: 8600 uuf; $\pm 1\%$; 200 VDCW.	CX-104-39
C3155	CAPACITOR, FIXED, PLASTIC DI-ELECTRIC: 8000 uuf; $\pm 1\%$; 200 VDCW.	CX-104-38
C3156	CAPACITOR, FIXED, PLASTIC DI-ELECTRIC: 7300 uuf; $\pm 1\%$; 200 VDCW.	CX-104-46
C3157	CAPACITOR, FIXED, PLASTIC DI-ELECTRIC: 142,000 uuf; $\pm 1\%$; 200 VDCW.	CX-104-57
C3158	Same as C3102.	
C3159	Same as C3119.	
C3160	CAPACITOR, FIXED, CERAMIC DI-ELECTRIC: 20,000 uuf; $+60\%$ -40% ; 150 VDCW.	CC-100-35
C3161	Same as C3102.	
C3162	NOT USED	
C3163	CAPACITOR, FIXED, ELECTROLYTIC: tantalum; 6.8 uf; $\pm 20\%$; 6 VDCW; polarized, insulated tubular case.	CE-106

PARTS LIST (CONT'D)

100 CYCLE SELECTOR DECK

REF SYMBOL	DESCRIPTION	TMC PART NUMBER
CR3101	SEMICONDUCTOR DEVICE, DIODE: silicon; 175 v max peak inverse voltage; 30 ma at 25°C and 15 ma at 150°C, two axial wire lead type terminals; hermetically sealed glass case.	1N463
CR3102	Same as CR3101.	
CR3103	Same as CR3101.	
J3101	CONNECTOR, RECEPTACLE, ELECTRICAL: RF type; 1 round male contact; straight type; series BNC to BNC.	JJ-211
J3102	Same as J3101.	
J3103	Same as J3101.	
J3104	CONNECTOR, RECEPTACLE, ELECTRICAL: 7 round #16 male contacts; straight type.	JJ-245
J3105	CONNECTOR, RECEPTACLE, ELECTRICAL: 11 round #20 female contacts; straight type.	JJ-242-3S
J3106	CONNECTOR, RECEPTACLE, ELECTRICAL: 2 female contacts; straight type.	JJ-119-2
J3107	Same as J3101.	
L3101	COIL, RADIO FREQUENCY: fixed; 29.82 mh, ±1%; 1 ohm dc resistance; 200 ma current rating, hermetically sealed metal case.	CL-286
P3101	CONNECTOR, PLUG, ELECTRICAL: RF; 1 round female coaxial contact; straight type; series miniature bayonet lock. (Part of W3101)	PL-204
P3102	Same as P3101. (Part of W3101)	
P3103	Same as P3101. (Part of W3102)	
P3104	Same as P3101. (Part of W3102)	
R3101	RESISTOR, FIXED, COMPOSITION: 2.2 megohm; ±10%; 1/2 watt.	RC20GF225K
R3102	RESISTOR, FIXED, COMPOSITION: 100,000 ohms; ±10%; 1/2 watt.	RC20GF104K
R3103	RESISTOR, VARIABLE, COMPOSITION: 100,000 ohms; ±10%; 1/2 watt.	RV106UX8B104A
R3104	Same as R3101.	
R3105	Same as R3102.	

PARTS LIST (CONT'D)

100 CYCLE SELECTOR DECK

REF SYMBOL	DESCRIPTION	TMC PART NUMBER
R3106	RESISTOR, FIXED, COMPOSITION: 6800 ohms; ±10%; 1/2 watt.	RC20GF682K
R3107	RESISTOR, FIXED, COMPOSITION: 2200 ohms; ±10%; 1/2 watt.	RC20GF222K
R3108	Same as R3102.	
R3109	RESISTOR, FIXED, COMPOSITION: 15,000 ohms; ±10%; 1 watt.	RC32GF153K
R3110	Same as R3102.	
R3111	RESISTOR, FIXED, COMPOSITION: 15,000 ohms; ±10%; 1/2 watt.	RC20GF153K
R3112	RESISTOR, FIXED, COMPOSITION: 33,000 ohms; ±10%; 1/2 watt.	RC20GF333K
R3113	RESISTOR, FIXED, COMPOSITION: 22,000 ohms; ±10%; 1/2 watt.	RC20GF223K
R3114	Same as R3102.	
R3115	RESISTOR, FIXED, COMPOSITION: 150 ohms; ±10%; 1/2 watt.	RC20GF151K
R3116	RESISTOR, FIXED, COMPOSITION: 3300 ohms; ±10%; 1/2 watt.	RC20GF332K
R3117	Same as R3116.	
R3118	Same as R3102.	
R3119	RESISTOR, FIXED, COMPOSITION: 4,700 ohms; ±10%; 1/2 watt.	RC20GF472K
R3120	Same as R3113.	
R3121	RESISTOR, FIXED, COMPOSITION: 47 ohms; ±10%; 1/2 watt.	RC20GF470K
R3122	Same as R3102.	
R3123	NOT USED	
R3124	Same as R3102.	
R3125	Same as R3113.	
R3126	Same as R3115.	
R3127	Same as R3107.	
R3128	Same as R3115.	
R3129	Same as R3102.	
R3130	RESISTOR, FIXED, COMPOSITION: 2200 ohms; ±10%; 1 watt.	RC32GF222K

PARTS LIST (CONT'D)

100 CYCLE SELECTOR DECK

REF SYMBOL	DESCRIPTION	TMC PART NUMBER
R3131	Same as R3130.	
R3132	Same as R3113.	
R3133	Same as R3102.	
R3134	Same as R3121.	
R3135	RESISTOR, FIXED, COMPOSITION: 470 ohms; $\pm 10\%$; 1/2 watt.	RC20GF471K
R3136	Same as R3102.	
R3137	Same as R3106.	
R3138	RESISTOR, FIXED, COMPOSITION: 3900 ohms; $\pm 10\%$; 1/2 watt.	RC20GF392K
R3139	Same as R3107.	
R3140	RESISTOR, VARIABLE, COMPOSITION: 10,000 ohms; $\pm 10\%$; 1/2 watt.	RV106UX8B103A
R3141	RESISTOR, FIXED, COMPOSITION: 27,000 ohms; $\pm 10\%$; 1/2 watt.	RC20GF273K
R3142	RESISTOR, FIXED, COMPOSITION: 10,000 ohms; $\pm 10\%$; 1/2 watt.	RC20GF103K
R3143	Same as R3113.	
S3101 A, B, C, D, E, F, G	SWITCH, ROTARY: 7 sections; 12 position; non-shorting type contacts; contacts rated 1 amp, 28 volts dc or 5 amp at 110 volts ac.	SW-293
S3102	SWITCH, TOGGLE: SPDT: 5A-125 vac; 5A-250 vac.	ST-106
T3101	TRANSFORMER, RADIO FREQUENCY: inductance 11.4 mh; hermetically sealed metal case.	TZ-104
T3102	TRANSFORMER PULSE: 3 windings; winding no. 1, 4.7 mh; turns ratio 5:5:1.	TF-228-K15
TB3101	TERMINAL BOARD ASSEMBLY	A2254-4
TB3102	TERMINAL BOARD ASSEMBLY	A2271-4
TP3101	TERMINAL, FEEDTHRU, INSULATED: 0.740" lg x 3/16" dia; 3.32 press-fit stud; teflon insulated, 2000 v.	TE-169-1
TP3102	Same as TP3101.	
TP3103	Same as TP3101.	
V3101	TUBE, ELECTRON: radio frequency amplifier pentode; 7 pin miniature.	6AS6

PARTS LIST (CONT'D)

100 CYCLE SELECTOR DECK

REF SYMBOL	DESCRIPTION	TMC PART NUMBER
V3102	TUBE, ELECTRON: high-mu triode; 7 pin miniature.	6AB4
V3103	TUBE, ELECTRON: sharp-cutoff pentode; 7 pin miniature.	6AU6
V3104	Same as V3103.	
V3105 A, B	TUBE, ELECTRON: high-mu triode sharp-cutoff pentode; 9 pin miniature.	6AW8A
W3101	CABLE ASSEMBLY, RADIO FREQUENCY: consists of 7' of RF cable RG174/U and two connectors symbol #P3101, P3102.	CA-480-68-7
W3102	Same as W3101. Consists of two connectors symbol #P3103, P3104.	
XC3101 thru XC3124	NOT USED	
XC3125A, B, C	SOCKET, ELECTRON TUBE: octal type.	TS101P01
XV3101	SOCKET, ELECTRON TUBE: 7 pin miniature.	TS102P01
XV3102 thru XV3104	Same as XV3101.	
XV3105	SOCKET, ELECTRON TUBE: 9 pin miniature.	TS103P01
XY3101	SOCKET, CRYSTAL: 2 contacts; 0.050" dia spaced 0.486" c to c.	TS-104-2
XY3102 thru XY3110	Same as XY3101.	
XZ3101	Same as XC3125A, B, C.	
Y3101	CRYSTAL UNIT, QUARTZ: 4.000 kc, $\pm 0.005\%$; 0° to +50°C operating temperature range; parallel resonance, 10 uuf, ± 0.5 uuf load capacitance; fundamental operation; type HC-13/U holder.	CR-109-15
Y3102	CRYSTAL UNIT, QUARTZ: 3.900 kc, $\pm 0.005\%$; 0° to +50°C operating temperature range; parallel resonance, 10 uuf, ± 0.5 uuf load capacitance; fundamental operation; type HC-13/U holder.	CR-109-14

PARTS LIST (CONT'D)

100 CYCLE SELECTOR DECK

REF SYMBOL	DESCRIPTION	TMC PART NUMBER
Y3103	CRYSTAL UNIT, QUARTZ: 3.800 kc, $\pm .005\%$; 0° to +50°C operating temperature range; parallel resonance, 10 uuf, +0.5 uuf load capacitance; fundamental operation; type HC-13/U holder.	CR-109-13
Y3104	CRYSTAL UNIT, QUARTZ: 3.700 kc, $\pm .005\%$; 0° to +50°C operating temperature range; parallel resonance, 10 uuf; ± 0.5 uuf load capacitance; fundamental operation; type HC-13/U holder.	CR-109-12
Y3105	CRYSTAL UNIT, QUARTZ: 3.600 kc, $\pm .005\%$; 0° to +50°C operating temperature range; parallel resonance, 10 uuf, ± 0.5 uuf load capacitance; fundamental operation; type HC-13/U holder.	CR-109-11
Y3106	CRYSTAL UNIT, QUARTZ: 3.500 kc, $\pm .005\%$; 0° to +50°C operating temperature range; parallel resonance, 10 uuf, ± 0.5 uuf load capacitance; fundamental operation; type HC-13/U holder.	CR-109-10
Y3107	CRYSTAL UNIT, QUARTZ: 3.400 kc, $\pm .005\%$; 0° to +50°C operating temperature range; parallel resonance, 10 uuf, ± 0.5 uuf load capacitance, fundamental operation; type HC-13/U holder.	CR-109-9
Y3108	CRYSTAL UNIT, QUARTZ: 3.300 kc, $\pm .005\%$; 0° to +50°C operating temperature range; parallel resonance, 10 uuf, ± 0.5 uuf load capacitance, fundamental operation; type HC-13/U holder.	CR-109-8
Y3109	CRYSTAL UNIT, QUARTZ: 3.200 kc, $\pm .005\%$; 0° to +50°C operating temperature range; parallel resonance, 10 uuf, ± 0.5 uuf load capacitance, fundamental operation; type HC-13/U holder.	CR-109-7
Y3110	CRYSTAL UNIT, QUARTZ: 3.100 kc, $\pm .005\%$; 0° to +50°C operating temperature range; parallel resonance, 10 uuf, ± 0.5 uuf load capacitance, fundamental operation; type HC-13/U holder.	CR-109-6

PARTS LIST (CONT'D)

100 CYCLE SELECTOR DECK

REF SYMBOL	DESCRIPTION	TMC PART NUMBER
Z3101	CALIBRATOR, FREQUENCY: operating frequency 1 mc; frequency stability 1×10^{-8} after 24 hours warm-up period; ambient temperature range $+15^{\circ}\text{C}$ to $+65^{\circ}\text{C}$, hermetically sealed metal case; standard 6 pin plug-in type.	NF-109-1

1 KC SELECTOR DECK

C3201	CAPACITOR, FIXED, CERAMIC DIELECTRIC: 1000 uuf; $\pm 10\%$; 500 VDCW.	CC-100-9
C3202	CAPACITOR, FIXED, MICA DIELECTRIC: 100 uuf; $\pm 10\%$; 500 VDCW.	CM15C101K
C3203	CAPACITOR, FIXED, MICA DIELECTRIC: 560 uuf; $\pm 5\%$; 500 VDCW.	CM20B561J
C3204	Same as C3203.	
C3205	CAPACITOR, FIXED, PLASTIC DIELECTRIC: mylar, metallized; 1.0 uf; $\pm 10\%$; 200 VDCW.	CN112A105K2
C3206	Same as C3201.	
C3207	CAPACITOR, FIXED, MICA DIELECTRIC: 330 uuf; $\pm 10\%$; 500 VDCW.	CM15C331K
C3208	NOT USED	
C3209	CAPACITOR, FIXED, CERAMIC DIELECTRIC: 10,000 uuf; GMV; 500 VDCW.	CC-100-16
C3210	CAPACITOR, FIXED, MICA DIELECTRIC: 68 uuf; $\pm 5\%$; 500 VDCW.	CM15C680J
C3211	CAPACITOR, FIXED, MICA DIELECTRIC: 1100 uuf; $\pm 5\%$; 500 VDCW.	CM20B112J
C3212	Same as C3205.	
C3213	CAPACITOR, FIXED, ELECTROLYTIC: tantalum; 6.8 uf, $\pm 20\%$; 6 VDCW polarized; insulated tubular case.	CE-106
C3214	CAPACITOR, FIXED, MICA DIELECTRIC: 5 uuf; $\pm 5\%$; 500 VDCW.	CM15C050J
C3215	Same as C3202.	
C3216	NOT USED	

PARTS LIST (CONT'D)

1 KC SELECTOR DECK

REF SYMBOL	DESCRIPTION	TMC PART NUMBER
C3217	Same as C3214.	
C3218	Same as C3205.	
C3219	CAPACITOR, FIXED, CERAMIC DIELECTRIC: 20,000 uuf; +80% -20%; 500 VDCW.	CC-100-24
C3220	Same as C3205.	
C3221	Same as C3213.	
C3222	Same as C3219.	
C3223	Same as C3214.	
C3224	CAPACITOR, FIXED, METALIZED PAPER DIELECTRIC: 2.0 uf; ±20%; 200 VDCW.	CP106H205-4
C3225	NOT USED	
C3226	Same as C3214.	
C3227	Same as C3202.	
C3228	NOT USED	
C3229 A, B, C	CAPACITOR, FIXED, ELECTROLYTIC: triple section; 20 uf each section; 450 VDCW; polarized, tubular case, plug-in type.	CE-108-1
C3230	Same as C3205.	
C3231	CAPACITOR, FIXED, MICA DIELECTRIC: 20 uuf; ±5%; 500 VDCW.	CM15C200J
C3232	CAPACITOR, VARIABLE GLASS DIELECTRIC: 2 to 30 uuf; ±100%; 1000 VDCW.	CV-108-4
C3233 thru C3241	Same as C3232.	
C3242	CAPACITOR, FIXED, PLASTIC DIELECTRIC: 9400 uuf; ±1%; 200 VDCW.	CX-104-40
C3243	CAPACITOR, FIXED, GLASS DIELECTRIC: 595 uuf; ±1%; 500 VDCW.	CY15C5950F
C3244	CAPACITOR, FIXED, GLASS DIELECTRIC: 645 uuf; ±1%; 500 VDCW.	CY15C6450F
C3245	CAPACITOR, FIXED, GLASS DIELECTRIC: 705 uuf; ±1%; 500 VDCW.	CY15C6050F
C3246	CAPACITOR, FIXED, GLASS DIELECTRIC: 770 uuf; ±1%; 500 VDCW.	CY15C771F

PARTS LIST (CONT'D)

1 KC SELECTOR DECK

REF SYMBOL	DESCRIPTION	TMC PART NUMBER
C3247	CAPACITOR, FIXED, GLASS DIELECTRIC: 885 uuf; $\pm 1\%$; 500 VDCW.	CY15C8850F
C3248	CAPACITOR, FIXED, GLASS DIELECTRIC: 930 uuf; $\pm 1\%$; 500 VDCW.	CY15C931F
C3249	CAPACITOR, FIXED, GLASS DIELECTRIC: 1035 uuf; $\pm 1\%$; 500 VDCW.	CY20C10350F
C3250	CAPACITOR, FIXED, GLASS DIELECTRIC: 1145 uuf; $\pm 1\%$; 500 VDCW.	CY20C11450F
C3251	CAPACITOR, FIXED, GLASS DIELECTRIC: 1275 uuf; $\pm 1\%$; 500 VDCW.	CY20C12750F
C3252	CAPACITOR, FIXED, PLASTIC DIELECTRIC: 12, 500 uuf; $\pm 1\%$; 200 VDCW.	CX-104-43
C3253	CAPACITOR, FIXED, GLASS DIELECTRIC: 740 uuf; $\pm 1\%$; 500 VDCW.	CY15C741J
C3254	CAPACITOR, FIXED, GLASS DIELECTRIC: 790 uuf; $\pm 1\%$; 500 VDCW.	CY15C791F
C3255	CAPACITOR, FIXED, GLASS DIELECTRIC: 865 uuf; $\pm 1\%$; 500 VDCW.	CY15C8650F
C3256	CAPACITOR, FIXED, GLASS DIELECTRIC: 940 uuf; $\pm 1\%$; 500 VDCW.	CY15C941F
C3257	CAPACITOR, FIXED, GLASS DIELECTRIC: 1025 uuf; $\pm 1\%$; 500 VDCW.	CY20C10250F
C3258	CAPACITOR, FIXED, GLASS DIELECTRIC: 1110 uuf; $\pm 1\%$; 500 VDCW.	CY20C1111F
C3259	CAPACITOR, FIXED, GLASS DIELECTRIC: 1230 uuf; $\pm 1\%$; 500 VDCW.	CY20C1231F
C3260	CAPACITOR, FIXED, GLASS DIELECTRIC: 1345 uuf; $\pm 1\%$; 500 VDCW.	CY20C13450F
C3261	CAPACITOR, FIXED, GLASS DIELECTRIC: 1470 uuf; $\pm 1\%$; 500 VDCW.	CY20C1471F
C3262	CAPACITOR, FIXED, PLASTIC DIELECTRIC: 8600 uuf; $\pm 1\%$; 500 VDCW.	CX-104-39
C3263	CAPACITOR, FIXED, GLASS DIELECTRIC: 490 uuf; $\pm 1\%$; 500 VDCW.	CY15C941F
C3264	CAPACITOR, FIXED, GLASS DIELECTRIC: 535 uuf; $\pm 1\%$; 500 VDCW.	CY15C5350F
C3265	CAPACITOR, FIXED, GLASS DIELECTRIC: 575 uuf; $\pm 1\%$; 500 VDCW.	CY15C5750F
C3266	CAPACITOR, FIXED, GLASS DIELECTRIC: 620 uuf; $\pm 1\%$; 500 VDCW.	CY15C621F

PARTS LIST (CONT'D)

1 KC SELECTOR DECK

REF SYMBOL	DESCRIPTION	TMC PART NUMBER
C3267	CAPACITOR, FIXED, GLASS DIELECTRIC: 675 uuf; $\pm 1\%$; 500 VDCW.	CY15C6750F
C3268	CAPACITOR, FIXED, GLASS DIELECTRIC: 735 uuf; $\pm 1\%$; 500 VDCW.	CY15C7350F
C3269	CAPACITOR, FIXED, GLASS DIELECTRIC: 810 uuf; $\pm 1\%$; 500 VDCW.	CY15C811F
C3270	CAPACITOR, FIXED, GLASS DIELECTRIC: 880 uuf; $\pm 1\%$; 500 VDCW.	CY15C881F
C3271	CAPACITOR, FIXED, GLASS DIELECTRIC: 970 uuf; $\pm 1\%$; 500 VDCW.	CY15C971F
C3272	CAPACITOR, VARIABLE, MICA DIELECTRIC: compression type; capacitance less than 190 uuf to more than 900 uuf; 350 VDCW.	CV-111-11
C3273	CAPACITOR, VARIABLE, MICA DIELECTRIC: compression type; capacitance less than 390 uuf to more than 1400 uuf; 350 VDCW.	CV-111-16
C3274	Same as C3272.	
CR3201	SEMICONDUCTOR DEVICE, DIODE: silicone; 175 v max peak inverse voltage; 30 ma at 25°C and 15 ma at 150°C; two axial wire lead type terminals; hermetically sealed glass case.	1N463
CR3202	SEMICONDUCTOR DEVICE, SET: 4 matched diodes; 80 v max continuous working voltage; peak rectified current, 90 ma; max power dissipation; 80 mw; max FWD current plug 1 volt, 4 ma; max reverse current at minus 5 volts, 5 ua; min reverse voltage for zero dynamic resistance; 100 volts.	DD-100
CR3203	Same as CR3201.	
CR3204	Same as CR3201.	
J3201	CONNECTOR, RECEPTACLE: ELECTRICAL: RF type; 1 round male contact; straight type; series BNC to BNC.	JJ-211
J3202 thru J3204	Same as J3201.	
J3205	CONNECTOR, RECEPTACLE, ELECTRICAL: 7 round #16 male contacts; straight type.	JJ-245
J3206	CONNECTOR, RECEPTACLE, ELECTRICAL: 11 round #20 female contacts; straight type.	JJ-242-3S

PARTS LIST (CONT'D)

1 KC SELECTOR DECK

REF SYMBOL	DESCRIPTION	TMC PART NUMBER
P3201	CONNECTOR, PLUG, ELECTRICAL: RF: 1 round female coaxial contact; straight type; series miniature bayonet lock. Part of W3201.	PL-204
P3202	Same as P3201. Part of W3201.	
P3203	Same as P3201. Part of W3202.	
P3204	Same as P3201. Part of W3202.	
R3201	RESISTOR, FIXED, COMPOSITION: 2.2 megohms; $\pm 10\%$; 1/2 watt.	RC20GF225K
R3202	RESISTOR, FIXED, COMPOSITION: 100,000 ohms; $\pm 10\%$; 1/2 watt.	RC20GF104K
R3203	RESISTOR, VARIABLE, COMPOSITION: 100,000 ohms; $\pm 20\%$; 1/2 watt.	RV106UX8B104B
R3204	RESISTOR, FIXED, COMPOSITION: 1.5 megohms; $\pm 10\%$; 1/2 watt.	RC20GF155K
R3205	Same as R3202.	
R3206	RESISTOR, FIXED, COMPOSITION: 6800 ohms; $\pm 10\%$; 1/2 watt.	RC20GF682K
R3207	RESISTOR, FIXED, COMPOSITION: 2200 ohms; $\pm 10\%$; 1/2 watt.	RC20GF222K
R3208	Same as R3202.	
R3209	RESISTOR, FIXED, COMPOSITION: 15,000 ohms; $\pm 10\%$; 1 watt.	RC32GF153K
R3210	Same as R3202.	
R3211	RESISTOR, FIXED, COMPOSITION: 33,000 ohms; $\pm 10\%$; 1/2 watt.	RC20GF333K
R3212	RESISTOR, FIXED, COMPOSITION: 470 ohms; $\pm 10\%$; 1/2 watt.	RC20GF471K
R3213	RESISTOR, FIXED, COMPOSITION: 15,000 ohms; $\pm 10\%$; 1/2 watt.	RC20GF153K
R3214	Same as R3202.	
R3215	RESISTOR, FIXED, COMPOSITION: 47 ohms; $\pm 10\%$; 1/2 watt.	RC20GF470K
R3216	RESISTOR, FIXED, COMPOSITION: 22,000 ohms; $\pm 10\%$; 1/2 watt.	RC20GF223K
R3217	Same as R3215.	
R3218	Same as R3215.	
R3219	RESISTOR, VARIABLE, COMPOSITION: 100 ohms; $\pm 20\%$; 1/2 watt.	RV106UX8B101B

PARTS LIST (CONT'D)

1 KC SELECTOR DECK

REF SYMBOL	DESCRIPTION	TMC PART NUMBER
R3220	Same as R3202.	
R3221	RESISTOR, FIXED, COMPOSITION: 4,700 ohms; $\pm 10\%$; 1/2 watt.	RC20GF472K
R3222	Same as R3215.	
R3223	RESISTOR, FIXED, COMPOSITION: 150 ohms; $\pm 10\%$; 1/2 watt.	RC20GF151K
R3224	Same as R3216.	
R3225	RESISTOR, FIXED, COMPOSITION: 3300 ohms; $\pm 10\%$; 1/2 watt.	RC20GF332K
R3226	RESISTOR, FIXED, COMPOSITION: 2200 ohms; $\pm 10\%$; 1 watt.	RC32GF222K
R3227	Same as R3226.	
R3228	Same as R3216.	
R3229	Same as R3215.	
R3230	Same as R3225.	
R3231	RESISTOR, FIXED, COMPOSITION: 1 megohm; $\pm 10\%$; 1/2 watt.	RC20GF105K
S3201A, B, C, D, E, F	SWITCH, ROTARY: 9 sections; 12 positions; non-shorting type contact rating; 1 amp at 28 volts dc or 5 amp at 110 vac.	SW-291
T3201	TRANSFORMER, RADIO FREQUENCY: operation frequency range 27 kc to 36 kc; inductance 1.90 mh; hermetically sealed metal case.	TZ-103-4
T3202	TRANSFORMER, RADIO FREQUENCY: operating frequency range 30.5 kc to 39.5 kc; inductance 1.20 mh; hermetically sealed metal case.	TZ-103-5
T3203	TRANSFORMER, RADIO FREQUENCY: operating frequency range 30.5 kc to 39.5 kc; inductance 1.65 mh; hermetically sealed metal case.	TZ-103-6
TB3201	TERMINAL BOARD ASSEMBLY	A2263-4
TB3202	TERMINAL BOARD ASSEMBLY	A2268-4
TP3201	TERMINAL, FEEDTHRU, INSULATED: 0.740" lg x 3/16" dia; 3/32 press-fit stud; teflon insulated, 2000 v.	TE-169-1
TP3202 thru TP3205	Same as TP3201.	

PARTS LIST (CONT'D)

1 KC SELECTOR DECK

REF SYMBOL	DESCRIPTION	TMC PART NUMBER
V3201	TUBE, ELECTRON: radio frequency amplifier pentode; 7 pin miniature.	6AS6
V3202	TUBE, ELECTRON: high-mu triode; 7 pin miniature.	6AB4
V3203	TUBE, ELECTRON: sharp-cutoff pentode; 7 pin miniature.	6AH6
V3204	TUBE, ELECTRON: sharp-cutoff pentode; 7 pin miniature.	6AU6
W3201	CABLE ASSEMBLY, RADIO FREQUENCY: consists of 7' of RF cable RG174/U, and two connectors symbol #P3201, P3202.	CA-480-68-7
W3202	Same as W3201 consists of two connectors symbol #P3203, P3204.	
XC3201 thru XC3228	NOT USED	
XC3229	SOCKET, ELECTRON TUBE: octal type.	TS101P01
XCR3201	NOT USED	
XCR3202	SOCKET ELECTRON TUBE: 7 pin miniature.	TS-130-MBW
XV3201	SOCKET, ELECTRON TUBE: 7 pin miniature.	TS102P01
XV3202 thru XV3204	Same as XV3201.	
XY3201	SOCKET, CRYSTAL: 2 contacts; 0.050" dia spaced 0.486" c to c.	TS-104-2
XY3202 thru XY3210	Same as XY3201.	
Y3201	CRYSTAL UNIT, QUARTZ: 36.000 kc, $\pm 0.005\%$; 0° to +50°C operating temperature range; parallel resonance; 10 uuf; ± 0.5 uuf load capacitance; fundamental operation; type HC-13/U holder.	CR-109-25
Y3202	CRYSTAL UNIT, QUARTZ: 35.000 kc, $\pm 0.005\%$; 0° to +50°C operating temperature range; parallel resonance; 10 uuf; ± 0.5 uuf load capacitance; fundamental operation; type HC-13/U holder.	CR-109-24

PARTS LIST (CONT'D)

1 KC SELECTOR DECK

REF SYMBOL	DESCRIPTION	TMC PART NUMBER
Y3203	CRYSTAL UNIT, QUARTZ: 34.000 kc, $\pm 0.005\%$; 0° to +50°C operating temperature range; parallel resonance; 10 uuf; ± 0.5 uuf load capacitance; fundamental operation; type HC-13/U holder.	CR-109-23
Y3204	CRYSTAL UNIT, QUARTZ: 33.000 kc, $\pm 0.005\%$; 0° to +50°C operating temperature range; parallel resonance; 10 uuf; ± 0.5 uuf load capacitance; fundamental operation; type HC-13/U holder.	CR-109-22
Y3205	CRYSTAL UNIT, QUARTZ: 32.000 kc, $\pm 0.005\%$; 0° to +50°C operating temperature range; parallel resonance; 10 uuf; ± 0.5 uuf load capacitance; fundamental operation; type HC-13/U holder.	CR-109-21
Y3206	CRYSTAL UNIT, QUARTZ: 31.000 kc, $\pm 0.005\%$; 0° to +50°C operating temperature range; parallel resonance; 10 uuf; ± 0.5 uuf load capacitance; fundamental operation; type HC-13/U holder.	CR-109-20
Y3207	CRYSTAL UNIT, QUARTZ: 30.000 kc, $\pm 0.005\%$; 0° to +50°C operating temperature range; parallel resonance; 10 uuf; ± 0.5 uuf load capacitance; fundamental operation; type HC-13/U holder.	CR-109-19
Y3208	CRYSTAL UNIT, QUARTZ: 29.000 kc, $\pm 0.005\%$; 0° to +50°C operating temperature range; parallel resonance; 10 uuf; ± 0.5 uuf load capacitance; fundamental operation; type HC-13/U holder.	CR-109-18
Y3209	CRYSTAL UNIT, QUARTZ: 28.000 kc, $\pm 0.005\%$; 0° to +50°C operating temperature range; parallel resonance; 10 uuf; ± 0.5 uuf load capacitance; fundamental operation; type HC-13/U holder.	CR-109-17
Y3210	CRYSTAL UNIT, QUARTZ: 27.000 kc, $\pm 0.005\%$; 0° to +50°C operating temperature range; parallel resonance; 10 uuf; ± 0.5 uuf load capacitance; fundamental operation; type HC-13/U holder.	CR-109-16

10 KC SELECTOR DECK

C3301	CAPACITOR, FIXED, CERAMIC DIELECTRIC: 1000 uuf; $\pm 10\%$; 500 VDCW.	CC-100-9
C3302	CAPACITOR, FIXED, MICA DIELECTRIC: 100 uuf; $\pm 10\%$; 500 VDCW.	CM15B101K

PARTS LIST (CONT'D)

10 KC SELECTOR DECK

REF SYMBOL	DESCRIPTION	TMC PART NUMBER
C3303	CAPACITOR, FIXED, MICA DIELECTRIC: 56 uuf; $\pm 5\%$; 500 VDCW.	CM15B560J
C3304	Same as C3303.	
C3305	CAPACITOR, FIXED, CERAMIC DIELECTRIC: 100,000 uuf; $+80\%$ -20% ; 300 VDCW.	CC-100-37
C3306	Same as C3301.	
C3307	Same as C3302.	
C3308	CAPACITOR, FIXED, CERAMIC DIELECTRIC: 10,000 uuf; GMV; 500 VDCW.	CC-100-16
C3309 A, B, C	CAPACITOR, FIXED, ELECTROLYTIC: triple section; 20 uf each section; 450 VDCW; polarized; tubular case; plug-in type.	CE-108-1
C3310	CAPACITOR, FIXED, MICA DIELECTRIC: 68 uuf; $\pm 5\%$; 500 VDCW.	CM15B680J
C3311	CAPACITOR, FIXED, MICA DIELECTRIC: 430 uuf; $\pm 5\%$; 500 VDCW.	CM15B431J
C3312 thru C3314	Same as C3305.	
C3315	CAPACITOR, FIXED, COMPOSITION: 05 uuf; $\pm 10\%$; 500 VDCW.	CM15B050K
C3316	Same as C3302.	
C3317	Same as C3305.	
C3318	CAPACITOR, FIXED, CERAMIC DIELECTRIC: 220,000 uuf; $+80\%$ -20% ; 10 VDCW.	CC-100-33
C3319	Same as C3308.	
C3320	CAPACITOR, FIXED, METALIZED PAPER DIELECTRIC: 2.0 uf; $\pm 20\%$; 200 VDCW.	CP-106-H-205-4
C3321	Same as C3305.	
C3322	NOT USED	
C3323	CAPACITOR, FIXED, CERAMIC DIELECTRIC: 20,000 uuf; $+80\%$ -20% ; 500 VDCW.	CC-100-24
C3324	CAPACITOR, FIXED, MICA DIELECTRIC: 22 uuf; $\pm 5\%$; 500 VDCW.	CM15B220J
C3325	Same as C3315.	
C3326	Same as C3315.	

PARTS LIST (CONT'D)

10 KC SELECTOR DECK

REF SYMBOL	DESCRIPTION	TMC PART NUMBER
C3327	Same as C3302.	
C3328	CAPACITOR, VARIABLE, GLASS DIELECTRIC: 1 to 30 uuf; $\pm 100\%$; 1000 VDCW.	CV-108-4
C3329 thru C3337	Same as C3328.	
C3338	CAPACITOR, FIXED, MICA DIELECTRIC: 1100 uuf; $\pm 5\%$; 500 VDCW.	CM20B112J
C3339	CAPACITOR, FIXED, GLASS DIELECTRIC: 75 uuf; $\pm 1\%$; 500 VDCW.	CY10C750F
C3340	CAPACITOR, FIXED, GLASS DIELECTRIC: 91 uuf; $\pm 1\%$; 500 VDCW.	CY10C910F
C3341	CAPACITOR, FIXED, GLASS DIELECTRIC: 96 uuf; $\pm 1\%$; 500 VDCW.	CY10C960F
C3342	CAPACITOR, FIXED, GLASS DIELECTRIC: 106 uuf; $\pm 1\%$; 500 VDCW.	CY10C1060F
C3343	CAPACITOR, FIXED, GLASS DIELECTRIC: 114 uuf; $\pm 1\%$; 500 VDCW.	CY10C1140F
C3344	CAPACITOR, FIXED, GLASS DIELECTRIC: 126 uuf; $\pm 1\%$; 500 VDCW.	CY10C1260F
C3345	CAPACITOR, FIXED, GLASS DIELECTRIC: 145 uuf; $\pm 1\%$; 500 VDCW.	CY10C1450F
C3346	CAPACITOR, FIXED, GLASS DIELECTRIC: 150 uuf; $\pm 1\%$; 500 VDCW.	CY10C151F
C3347	CAPACITOR, FIXED, GLASS DIELECTRIC: 180 uuf; $\pm 1\%$; 500 VDCW.	CY10C181F
C3348	CAPACITOR, FIXED, MICA DIELECTRIC: 820 uuf; $\pm 5\%$; 500 VDCW.	CM20B821J
C3349	CAPACITOR, FIXED, GLASS DIELECTRIC: 52 uuf; $\pm 1\%$; 500 VDCW.	CY10C520F
C3350	CAPACITOR, FIXED, GLASS DIELECTRIC: 56 uuf; $\pm 1\%$; 500 VDCW.	CY10C560F
C3351	CAPACITOR, FIXED, GLASS DIELECTRIC: 64 uuf; $\pm 1\%$; 500 VDCW.	CY10C640F
C3352	CAPACITOR, FIXED, GLASS DIELECTRIC: 66 uuf; $\pm 1\%$; 500 VDCW.	CY10C660F
C3353	CAPACITOR, FIXED, GLASS DIELECTRIC: 73 uuf; $\pm 1\%$; 500 VDCW.	CY10C730F
C3354	CAPACITOR, FIXED, GLASS DIELECTRIC: 76 uuf; $\pm 1\%$; 500 VDCW.	CY10C760F

PARTS LIST (CONT'D)

10 KC SELECTOR DECK

REF SYMBOL	DESCRIPTION	TMC PART NUMBER
C3355	CAPACITOR, FIXED, GLASS DIELECTRIC: 89 uuf; $\pm 1\%$; 500 VDCW.	CY10C890F
C3356	CAPACITOR, FIXED, GLASS DIELECTRIC: 88 uuf; $\pm 1\%$; 500 VDCW.	CY10C880F
C3357	CAPACITOR, FIXED, GLASS DIELECTRIC: 100 uuf; $\pm 1\%$; 500 VDCW.	CY10C101F
C3358	CAPACITOR, FIXED, MICA DIELECTRIC: 390 uuf; $\pm 5\%$; 500 VDCW.	CM20B391J
C3359	CAPACITOR, FIXED, GLASS DIELECTRIC: 34 uuf; $\pm 1\%$; 500 VDCW.	CY10C340F
C3360	Same as C3359.	
C3361	CAPACITOR, FIXED, GLASS DIELECTRIC: 38 uuf; $\pm 1\%$; 500 VDCW.	CY10C380F
C3362	CAPACITOR, FIXED, GLASS DIELECTRIC: 40 uuf; $\pm 1\%$; 500 VDCW.	CY10C400F
C3363	CAPACITOR, FIXED, GLASS DIELECTRIC: 44 uuf; $\pm 1\%$; 500 VDCW.	CY10C440F
C3364	CAPACITOR, FIXED, GLASS DIELECTRIC: 47 uuf; $\pm 1\%$; 500 VDCW.	CY10C470F
C3365	Same as C3349.	
C3366	Same as C3350.	
C3367	CAPACITOR, FIXED, GLASS DIELECTRIC: 61 uuf; $\pm 1\%$; 500 VDCW.	CY10C610F
C3368	NOT USED	
C3369	CAPACITOR, FIXED, CERAMIC DIELECTRIC: 2 uuf; $\pm .5$ uuf; 500 VDCW.	CC21SL020D
C3370	CAPACITOR, VARIABLE, MICA DIELECTRIC: compression type; capacitance less than 140 uuf to more than 680 uuf; 350 VDCW.	CV-111-9
C3371	CAPACITOR, VARIABLE MICA DIELECTRIC: compression type; capacitance less than 50 uuf to more than 380 uuf; 380 VDCW.	CV-111-6
C3372	Same as C3371.	
CR3301	SEMICONDUCTOR DEVICE, DIODE: silicon; 175 v max peak inverse voltage; 30 ma at 25°C and 15 ma at 150°C, two axial wire lead type terminals; hermetically sealed glass case.	1N463

PARTS LIST (CONT'D)

10 KC SELECTOR DECK

REF SYMBOL	DESCRIPTION	TMC PART NUMBER
CR3302	SEMICONDUCTOR DEVICE, SET: 4 matched diodes; 80 v max continuous working voltage; peak rectified current 90 ma; max power dissipation, 80 mw. max forward current plus 1 volt 4 ma; max reverse current at minus 5 volts; 5 ua; min reverse voltage for zero dynamic resistance 100 volts.	DD-100
CR3303	SEMICONDUCTOR DEVICE, DIODE: silicon; 100 max reverse voltage; 40 ma at 25°C; and 10 ma at 150°C; hermetically sealed metal case.	1N303
CR3304	Same as CR3303.	
J3301	CONNECTOR, RECEPTACLE, ELECTRICAL: RF type; 1 round male contact; straight type; series BNC to BNC.	JJ-211
J3302 thru J3304	Same as J3301.	
J3305	CONNECTOR, RECEPTACLE, ELECTRICAL: 7 round #16 male contacts; straight type.	JJ-245
J3306	CONNECTOR, RECEPTACLE, ELECTRICAL: 14 round #20 female contacts; straight type.	JJ-242-3S
P3301	CONNECTOR, PLUG, ELECTRICAL: RF: 1 round female coaxial contact; straight type; series miniature bayonet lock. Part of W3301.	PL-204
P3302	Same as P3301. Part of W3301.	
P3303	Same as P3301. Part of W3302.	
P3304	Same as P3301. Part of W3302.	
R3301	RESISTOR, FIXED, COMPOSITION: 2.2 megohms; ±10%; 1/2 watt.	RC20GF225K
R3302	RESISTOR, FIXED, COMPOSITION: 100,000 ohms; ±10%; 1/2 watt.	RC20GF104K
R3303	RESISTOR, VARIABLE, COMPOSITION: 100,000 ohms; ±10%; 1/2 watt.	RV106UX8B104A
R3304	RESISTOR, FIXED, COMPOSITION: 1.5 megohms; ±10%; 1/2 watt.	RC20GF155K
R3305	Same as R3302.	
R3306	RESISTOR, FIXED, COMPOSITION: 6800 ohms; ±10%; 1/2 watt.	RC20GF682K

PARTS LIST (CONT'D)

10 KC SELECTOR DECK

REF SYMBOL	DESCRIPTION	TMC PART NUMBER
R3307	RESISTOR, FIXED, COMPOSITION: 2200 ohms; $\pm 10\%$; 1/2 watt.	RC20GF222K
R3308	Same as R3302.	
R3309	RESISTOR, FIXED, COMPOSITION: 15,000 ohms; $\pm 10\%$; 1 watt.	RC32GF153K
R3310	Same as R3302.	
R3311	RESISTOR, FIXED, COMPOSITION: 15,000 ohms; $\pm 10\%$; 1/2 watt.	RC20GF153K
R3312	RESISTOR, FIXED, COMPOSITION: 560 ohms; $\pm 10\%$; 1/2 watt.	RC20GF561K
R3313	RESISTOR, FIXED, COMPOSITION: 33,000 ohms; $\pm 10\%$; 1/2 watt.	RC20GF333K
R3314	Same as R3302.	
R3315	RESISTOR, FIXED, COMPOSITION: 150 ohms; $\pm 10\%$; 1/2 watt.	RC20GF151K
R3316	RESISTOR, FIXED, COMPOSITION: 3300 ohms; $\pm 10\%$; 1/2 watt.	RC20GF332K
R3317	RESISTOR, FIXED, COMPOSITION: 22,000 ohms; $\pm 10\%$; 1/2 watt.	RC20GF223K
R3318	RESISTOR, FIXED, COMPOSITION: 47 ohms; $\pm 10\%$; 1/2 watt.	RC20GF470K
R3319	Same as R3318.	
R3320	RESISTOR, FIXED, COMPOSITION: 470,000 ohms; $\pm 10\%$; 1/2 watt.	RC20GF474K
R3321	Same as R3302.	
R3322	RESISTOR, FIXED, COMPOSITION: 4,700 ohms; $\pm 10\%$; 1/2 watt.	RC20GF472K
R3323	Same as R3318.	
R3324	Same as R3315.	
R3325	Same as R3317.	
R3326	Same as R3316.	
R3327	Same as R3317.	
R3328	RESISTOR, FIXED, COMPOSITION: 2200 ohms; $\pm 10\%$; 1 watt.	RC32GF222K
R3329	Same as R3328.	
R3330	RESISTOR, VARIABLE, COMPOSITION: 100 ohms; $\pm 10\%$; 1/2 watt.	RV106UX8B101A

PARTS LIST (CONT'D)

10 KC SELECTOR DECK

REF SYMBOL	DESCRIPTION	TMC PART NUMBER
R3331	Same as R3318.	
R3332	Same as R3302.	
S3301A, B, C, D, E, F	SWITCH, ROTARY: 9 section; 12 positions; non-shorting type contacts; contact rating, 1 amp at 28 volts dc or 5 amp at 110 volts ac.	SW-291
T3301	TRANSFORMER, RADIO FREQUENCY: operating frequency range 320 kc to 410 kc; inductance 96 uh; hermetically sealed metal case.	TZ-103-1
T3302	TRANSFORMER, RADIO FREQUENCY: operating frequency range 355 kc to 455 kc; inductance 116 uh; hermetically sealed metal case.	TZ-103-2
T3303	TRANSFORMER, RADIO FREQUENCY: operating frequency range 355 kc to 455 kc; inductance 191 uh; hermetically sealed metal case.	TZ-103-3
TB3301	TERMINAL BOARD ASSEMBLY	A2248-4
TB3302	TERMINAL BOARD ASSEMBLY	A2264-4
TP3301	TERMINAL, FEEDTHRU, INSULATED: 0.740" lg x 3/16" dia; 3/32 press-fit stud; teflon insulated 2000 v.	TE-169-1
TP3302 thru TP3305	Same as TP3301.	
V3301	TUBE, ELECTRON: radio frequency amplifier pentode; 7 pin miniature.	6AS6
V3302	TUBE, ELECTRON: high-mu triode; 7 pin miniature.	6AB4
V3303	TUBE, ELECTRON: sharp-cutoff pentode; 7 pin miniature.	6AH6
V3304	TUBE, ELECTRON: sharp-cutoff pentode; 7 pin miniature.	6AU6
W3301	CABLE ASSEMBLY, RADIO FREQUENCY: consists of 7" of RF cable RG174/U and two connectors symbol #P3301, P3302.	CA-480-68-7
W3302	Same as W3301 consists of two connectors symbol #P3303, P3304.	
XC3301 thru XC3308	NOT USED	
XC3309	SOCKET, ELECTRON: octal type	TS101P01

PARTS LIST (CONT'D)

10 KC SELECTOR DECK

REF SYMBOL	DESCRIPTION	TMC PART NUMBER
XCR3301	NOT USED	
XCR3302	SOCKET, ELECTRON TUBE: 7 pin miniature.	TS-130-MBW
XV3301	SOCKET, ELECTRON TUBE: 7 pin miniature.	TS102P01
XV3302 thru XV3304	Same as XV3301.	
XY3301	SOCKET, CRYSTAL: 2 contacts; 0.050 in. dia. spaced 0.468 in. c to c.	TS-104-2
XY3302 thru XY3310	Same as XY3301.	
Y3301	CRYSTAL UNIT, QUARTZ: 410,000 kc, $\pm 0.001\%$; 0° to +50°C operating temperature range; parallel resonance; 10 uuf; ± 0.5 uuf load capacitance; fundamental operation; type HC-6/U holder.	CR-109-35
Y3302	CRYSTAL UNIT, QUARTZ: 400,000 kc, $\pm 0.001\%$; 0° to +50°C operating temperature range; parallel resonance; 10 uuf; ± 0.5 uuf load capacitance; fundamental operation; type HC-6/U holder.	CR-109-34
Y3303	CRYSTAL UNIT, QUARTZ: 390,000 kc, $\pm 0.001\%$; 0° to +50°C operating temperature range; parallel resonance; 10 uuf; ± 0.5 uuf load capacitance; fundamental operation; type HC-6/U holder.	CR-109-33
Y3304	CRYSTAL UNIT, QUARTZ: 380,000 kc, $\pm 0.001\%$; 0° to +50°C operating temperature range; parallel resonance; 10 uuf; ± 0.5 uuf load capacitance; fundamental operation; type HC-6/U holder.	CR-109-32
Y3305	CRYSTAL UNIT, QUARTZ: 370,000 kc, $\pm 0.001\%$; 0° to +50°C operating temperature range; parallel resonance; 10 uuf; ± 0.5 uuf load capacitance; fundamental operation; type HC-6/U holder.	CR-109-31
Y3306	CRYSTAL UNIT, QUARTZ: 360,000 kc, $\pm 0.001\%$; 0° to +50°C operating temperature range; parallel resonance; 10 uuf; ± 0.5 uuf load capacitance; fundamental operation; type HC-6/U holder.	CR-109-30
Y3307	CRYSTAL UNIT, QUARTZ: 350,000 kc, $\pm 0.001\%$; 0° to +50°C operating temperature range; parallel resonance; 10 uuf; ± 0.5 uuf load capacitance; fundamental operation; type HC-6/U holder.	CR-109-29

PARTS LIST (CONT'D)

10 KC SELECTOR DECK

REF SYMBOL	DESCRIPTION	TMC PART NUMBER
Y3308	CRYSTAL UNIT, QUARTZ: 340,000 kc, $\pm 0.001\%$; 0° to +50°C operating temperature range; parallel resonance; 10 uuf; ± 0.5 uuf load capacitance; fundamental operation; type HC-6/U holder.	CR-109-28
Y3309	CRYSTAL UNIT, QUARTZ: 330,000 kc, $\pm 0.001\%$; 0° to +50°C operating temperature range; parallel resonance; 10 uuf; ± 0.5 uuf load capacitance; fundamental operation; type HC-6/U holder.	CR-109-27
Y3310	CRYSTAL UNIT, QUARTZ: 320,000 kc, $\pm 0.001\%$; 0° to +50°C operating temperature range; parallel resonance; 10 uuf; ± 0.5 uuf load capacitance; fundamental operation; type HC-6/U holder.	CR-109-26

100 KC SELECTOR DECK

C3401	CAPACITOR, FIXED, MICA DIELECTRIC: 100 uuf; $\pm 10\%$; 500 VDCW.	CM15B101K
C3402	Same as C3401.	
C3403	CAPACITOR, FIXED, MICA DIELECTRIC: 20 uuf; $\pm 5\%$; 500 VDCW.	CM15B200J
C3404	Same as C3403.	
C3405	CAPACITOR, FIXED, CERAMIC DIELECTRIC: 10,000 uuf; GMV; 500 VDCW.	CC-100-16
C3406	Same as C3401.	
C3407	Same as C3401.	
C3408	CAPACITOR, FIXED, MICA DIELECTRIC: 18 uuf; $\pm 5\%$; 500 VDCW.	CM15B180J
C3409	CAPACITOR, FIXED, MICA DIELECTRIC: 33 uuf; $\pm 5\%$; 500 VDCW.	CM15B330J
C3410	CAPACITOR, FIXED, CERAMIC DIELECTRIC: 100,000 uuf; +80% -20%; 300 VDCW.	CC-100-37
C3411	Same as C3405.	
C3412	Same as C3410.	
C3413	Same as C3401.	
C3414	CAPACITOR, FIXED, CERAMIC DIELECTRIC: 1000 uuf; $\pm 10\%$; 500 VDCW.	CC-100-9
C3415	CAPACITOR, FIXED, CERAMIC DIELECTRIC: 20,000 uuf; +80% -20%; 500 VDCW.	CC-100-24
C3416	CAPACITOR, FIXED, MICA DIELECTRIC: 68 uuf; $\pm 5\%$; 500 VDCW.	CM15B680J

PARTS LIST (CONT'D)

100 KC SELECTOR DECK

REF SYMBOL	DESCRIPTION	TMC PART NUMBER
C3417	CAPACITOR, FIXED, MICA DIELECTRIC: 6200 uuf; $\pm 10\%$; 300 VDCW.	CM112E622K3S
C3418	Same as C3415.	
C3419	CAPACITOR, FIXED, MICA DIELECTRIC: 91 uuf, $\pm 10\%$; 500 VDCW.	CM15B910K
C3420	CAPACITOR, FIXED, MICA DIELECTRIC: 05 uuf; $\pm 5\%$; 500 VDCW.	CM15B050J
C3421	Same as C3401.	
C3422	Same as C3420.	
C3423	CAPACITOR, FIXED, MICA DIELECTRIC: 22 uuf; $\pm 5\%$; 500 VDCW.	CM15B220J
C3424	Same as C3416.	
C3425	Same as C3417.	
C3426 thru C3428	Same as C3415.	
C3429	CAPACITOR, FIXED, MICA DIELECTRIC: 75 uuf, $\pm 5\%$; 500 VDCW.	CM15B750J
C3430 thru C3432	Same as C3420.	
C3433	CAPACITOR, FIXED, MICA DIELECTRIC: 47 uuf; $\pm 5\%$; 500 VDCW.	CM15B470J
C3434	Same as C3401.	
C3435	Same as C3420.	
C3436	CAPACITOR, FIXED, MICA DIELECTRIC: 15 uuf; $\pm 5\%$; 500 VDCW.	CM15B150J
C3437	CAPACITOR, FIXED, CERAMIC DIELECTRIC: 100,000 uuf; $+80\%$ -20% ; 100 VDCW.	CC-100-28
C3438	CAPACITOR, FIXED, PLASTIC DIELECTRIC: 250,000 uuf; $\pm 20\%$; 100 VDCW.	CN112A254M1
C3439	Same as C3420.	
C3440	Same as C3415.	
C3441	Same as C3414.	
C3442 thru C3444	Same as C3415.	

PARTS LIST (CONT'D)

100 KC SELECTOR DECK

REF SYMBOL	DESCRIPTION	TMC PART NUMBER
C3445	CAPACITOR, FIXED, MICA DIELECTRIC: 62 uuf, $\pm 5\%$; 500 VDCW.	CM15B620J
C3446	Same as C3409.	
C3447	Same as C3420.	
C3448	CAPACITOR, VARIABLE, GLASS DIELECTRIC: 2 to 30 uuf; $\pm 100\%$; 1000 VDCW.	CV-108-4
C3449 thru C3457	Same as C3448.	
C3458	CAPACITOR, VARIABLE, GLASS DIELECTRIC: 0.1 to 12 uuf; $\pm 100\%$; 1000 VDCW.	CV-108-2
C3459 thru C3497	Same as C3458.	
C3498	Same as C3405.	
C3499	Same as C3420.	
C3801	Same as C3420.	
C3802	Same as C3415.	
C3803	Same as C3405.	
CR3401	SEMICONDUCTOR DEVICE, DIODE: germanium; 100 v min. peak inverse voltage; 60 ma at 250°C; axial wire lead type terminals; hermetically sealed glass case.	1N100
CR3402	Same as CR3401.	
CR3403	SEMICONDUCTOR DEVICE, DIODE: silicon; 175 v max. peak inverse voltage; 30 ma at 25°C and 15 ma at 150°C; two axial wire lead type terminals; hermetically sealed glass case.	1N463
CR3404 thru CR3407	Same as CR3401.	
CR3408	SEMICONDUCTOR DEVICE, DIODE: silicon; 200 volts; min. forward current 100 ma, 1.0 volts at 25°C; max. reverse current 0.10 ua at 25°C; operating temperature 15°C.	1N3070
CR3409 thru CR3411	Same as CR3408.	
CR3412	Same as CR3403.	

PARTS LIST (CONT'D)

100 KC SELECTOR DECK

REF SYMBOL	DESCRIPTION	TMC PART NUMBER
CR3413	Same as CR3403.	
CR3414	SEMICONDUCTOR DEVICE, DIODE: silicon; 180 v zener voltage; zener voltage tolerance 5%; 68 ma. max. zener impedance 90 ohms; one solder stud and one 10-32 thd stud type terminal; hermetically sealed metal and glass case.	1N2845B
CR3415	Same as CR3403.	
CR3416	Same as CR3403.	
J3401	CONNECTOR, RECEPTACLE, ELECTRICAL: RF type; 1 round male contact; straight type; series BNC to BNC.	JJ-211
J3402 thru J3407	Same as J3401.	
J3408	CONNECTOR, RECEPTACLE, ELECTRICAL: 14 round #20 female contacts; straight type.	JJ-242-3S
J3409	CONNECTOR, RECEPTACLE, ELECTRICAL: 7 round #16 male contacts; straight type.	JJ-245
L3401	COIL, RADIO FREQUENCY: fixed; 14.25 uh; $\pm 5\%$; .2 ohms dc resistance, 25 ma current rating; molded bakelite case.	CL-287-1
R3401	RESISTOR, FIXED, COMPOSITION: 56,000 ohms; $\pm 5\%$; 1/2 watt.	RC20GF563J
R3402	RESISTOR, FIXED, COMPOSITION: 10,000 ohms, $\pm 10\%$; 1/2 watt.	RC20GF103K
R3403	Same as R3402.	
R3404	RESISTOR, FIXED, COMPOSITION: 5600 ohms, $\pm 10\%$; 1/2 watt.	RC20GF562K
R3405	Same as R3401.	
R3406	Same as R3401.	
R3407	Same as R3404.	
R3408	Same as R3401.	
R3409	RESISTOR, FIXED, COMPOSITION: 820,000 ohms, $\pm 5\%$; 1/2 watt.	RC20GF842J
R3410	RESISTOR, FIXED, COMPOSITION: 100,000 ohms; $\pm 10\%$; 1/2 watt.	RC20GF104K
R3411	RESISTOR, FIXED, COMPOSITION: 390,000 ohms; $\pm 10\%$; 1/2 watt.	RC20GF394K

PARTS LIST (CONT'D)

100 KC SELECTOR DECK

REF SYMBOL	DESCRIPTION	TMC PART NUMBER
R3412	RESISTOR, FIXED, COMPOSITION: 120,000 ohms; $\pm 10\%$; 1/2 watt.	RC20GF124K
R3413	RESISTOR, FIXED, COMPOSITION: 6800 ohms; $\pm 10\%$; 1/2 watt.	RC20GF682K
R3414	RESISTOR, VARIABLE, COMPOSITION: 100,000 ohms; $\pm 10\%$; 1/2 watt.	RV106UX8B104A
R3415	Same as R3410.	
R3416	RESISTOR, FIXED, COMPOSITION: 2200 ohms; $\pm 10\%$; 1/2 watt.	RC20GF222K
R3417	RESISTOR, FIXED, COMPOSITION: 15,000 ohms; $\pm 10\%$; 1 watt.	RC32GF153K
R3418	Same as R3402.	
R3419	RESISTOR, FIXED, COMPOSITION: 3300 ohms; $\pm 5\%$; 1/2 watt.	RC20GF332J
R3420	Same as R3419.	
R3421	Same as R3419.	
R3422	RESISTOR, FIXED, COMPOSITION: 1500 ohms; $\pm 10\%$; 1/2 watt.	RC20GF152K
R3423	RESISTOR, FIXED, COMPOSITION: 100 ohms; $\pm 10\%$; 1/2 watt.	RC20GF101K
R3424	RESISTOR, FIXED, COMPOSITION: 4700 ohms; $\pm 10\%$; 1 watt.	RC20GF472K
R3425	RESISTOR, FIXED, COMPOSITION: 2.7 megohms; $\pm 10\%$; 1/2 watt.	RC20GF275K
R3426	Same as R3409.	
R3427	RESISTOR, FIXED, COMPOSITION: 22,000 ohms; $\pm 10\%$; 1/2 watt.	RC20GF223K
R3428	RESISTOR, FIXED, COMPOSITION: 47 ohms; $\pm 10\%$; 1/2 watt.	RC20GF470K
R3429	Same as R3410.	
R3430	Same as R3419.	
R3431	Same as R3423.	
R3432	RESISTOR, VARIABLE, COMPOSITION: 100 ohms; $\pm 10\%$; 1/2 watt.	RV106UX8B101A
R3433	Same as R3428.	
R3434	Same as R3428.	
R3435	RESISTOR, FIXED, COMPOSITION: 1.0 megohms; $\pm 10\%$; 1/2 watt.	RC20GF105K

PARTS LIST (CONT'D)

100 KC SELECTOR DECK

REF SYMBOL	DESCRIPTION	TMC PART NUMBER
R3436	Same as R3410.	
R3437	Same as R3427.	
R3438	RESISTOR, FIXED, COMPOSITION: 330,000 ohms; $\pm 10\%$; 1/2 watt.	RC20GF334K
R3439	Same as R3427.	
R3440	Same as R3419.	
R3441	RESISTOR, FIXED, COMPOSITION: 68 ohms; $\pm 10\%$; 1/2 watt.	RC20GF680K
R3442	RESISTOR, VARIABLE, COMPOSITION: 1000 ohms; $\pm 10\%$; 1/2 watt.	RV106UX8B102A
R3443	Same as R3410.	
R3444	Same as R3402.	
R3445	RESISTOR, FIXED, COMPOSITION: 1800 ohms; $\pm 10\%$; 1/2 watt.	RC20GF182K
R3446	Same as R3416.	
R3447	Same as R3416.	
R3448	Same as R3402.	
R3449	Same as R3427.	
R3450	Same as R3419.	
R3451	Same as R3435.	
R3452	RESISTOR, FIXED, COMPOSITION: 150 ohms; $\pm 10\%$; 1/2 watt.	RC20GF151K
R3453	Same as R3428.	
R3454	Same as R3413.	
R3455	Same as R3427.	
R3456	RESISTOR, FIXED, COMPOSITION: 330 ohms; $\pm 10\%$; 2 watt.	RC42GF331K
R3457	Same as R3410.	
R3458	RESISTOR, FIXED, COMPOSITION: 33,000 ohms; $\pm 10\%$; 1/2 watt.	RC20GF333K
R3459	Same as R3438.	
S3401 A, B, C, D, E, F, G	SWITCH, ROTARY: 7 sections; 12 posi- tions; non-shorting type contacts; con- tact rated at 1 amp at 28 volts dc or 5 amp at 110 volts ac.	SW-292

PARTS LIST (CONT'D)

100 KC SELECTOR DECK

REF SYMBOL	DESCRIPTION	TMC PART NUMBER
T3401	TRANSFORMER, PULSE: 3 windings; winding no. 1, 4.7 mh; turns ratio 5:5:1.	TF-228K15
T3402	TRANSFORMER, PULSE: 3 windings; winding no. 1, 0.1 mh; turns ratio 3:3:1.	TF-228U13
T3403	TRANSFORMER, RADIO FREQUENCY: operating frequency range 2.9 mc to 3.8 mc; primary inductance 14.2 uh; molded bakelite case.	TZ-105-1
T3404	TRANSFORMER, RADIO FREQUENCY: operating frequency range 3.25 mc to 4.25 mc; primary inductance 13.8 uh; molded bakelite case.	TZ-105-2
T3405	TRANSFORMER, RADIO FREQUENCY: operating frequency range 3.25 mc to 4.25 mc; primary inductance 15.0 uf; molded bakelite case.	TZ-102
T3406	TRANSFORMER, RADIO FREQUENCY: tuned, operating frequency range 3.25-4.25 mc; primary inductance 39.0 uh, ± 2 uh.	TT-177
TB3401	TERMINAL BOARD ASSEMBLY	A2262-4
TB3402	TERMINAL BOARD ASSEMBLY	A2439-4
TB3403	TERMINAL BOARD ASSEMBLY	A2438-4
TB3404	TERMINAL BOARD ASSEMBLY	A3061-4
TP3401	TERMINAL, FEEDTHRU, INSULATED: 0.740" lg x 3/16" dia.; 3/32 press-fit stud; teflon insulated 200 v.	TE-169-1
TP3402 thru TP3409	Same as TP3401.	
V3401 A, B	TUBE, ELECTRON: high-mu twin-triode, 9 pin miniature.	12AU7
V3402	TUBE, ELECTRON: radio frequency amplifier pentode; 7 pin miniature.	6AS6
V3403 A, B	TUBE, ELECTRON: high-mu twin-triode; 9 pin miniature.	12AT7
V3404	TUBE, ELECTRON: sharp-cutoff pentode; 7 pin miniature.	6AH6
V3405	Same as V3404.	
V3406	Same as V3404.	
XV3401	SOCKET, ELECTRON TUBE: 9 pin miniature.	TS103P01

PARTS LIST (CONT'D)

100 KC SELECTOR DECK

REF SYMBOL	DESCRIPTION	TMC PART NUMBER
XV3402	SOCKET, ELECTRON TUBE: 7 pin miniature.	TS102P01
XV3403	Same as XV3401.	
XV3404 thru XV3406	Same as XV3402.	
XY3401	SOCKET, CRYSTAL: 2 contacts, 0.050 in. dia., spaced 0.486 in. c to c.	TS-104-2
XY3402 thru XY3410	Same as XY3401.	
Y3401	CRYSTAL UNIT, QUARTZ: 3.800000 mc; $\pm 0.001\%$; 0° to +50°C operating temperature range; parallel resonance; 10 uuf; ± 0.5 uuf load capacitance; fundamental operation; type HC-6/U holder.	CR-109-45
Y3402	CRYSTAL UNIT, QUARTZ: 3.700000 mc; $\pm 0.001\%$; 0° to +50°C operating temperature range; parallel resonance; 10 uuf; ± 0.5 uuf load capacitance; fundamental operation; type HC-6/U holder.	CR-109-44
Y3403	CRYSTAL UNIT, QUARTZ: 3.600000 mc, $\pm 0.001\%$; 0° to +50°C operating temperature range; parallel resonance; 10 uuf; ± 0.5 uuf load capacitance; fundamental operation; type HC-6/U holder.	CR-109-43
Y3404	CRYSTAL UNIT, QUARTZ: 3.500000 mc, $\pm 0.001\%$; 0° to +50°C operating temperature range; parallel resonance; 10 uuf; ± 0.5 uuf load capacitance; fundamental operation; type HC-6/U holder.	CR-109-42
Y3405	CRYSTAL UNIT, QUARTZ: 3.400000 mc, $\pm 0.001\%$; 0° to +50°C operating temperature range; parallel resonance; 10 uuf; ± 0.5 uuf load capacitance; fundamental operation; type HC-6/U holder.	CR-109-41
Y3406	CRYSTAL UNIT, QUARTZ: 3.300000 mc, $\pm 0.001\%$; 0° to +50°C operating temperature range; parallel resonance; 10 uuf; ± 0.5 uuf load capacitance; fundamental operation; type HC-6/U holder.	CR-109-40
Y3407	CRYSTAL UNIT, QUARTZ: 3.200000 mc, $\pm 0.001\%$; 0° to +50°C operating temperature range; parallel resonance; 10 uuf; ± 0.5 uuf load capacitance; fundamental operation; type HC-6/U holder.	CR-109-39

PARTS LIST (CONT'D)

100 KC SELECTOR DECK

REF SYMBOL	DESCRIPTION	TMC PART NUMBER
Y3408	CRYSTAL UNIT, QUARTZ: 3.100000 mc, $\pm .001\%$; 0° to +50°C operating temperature range; parallel resonance; 10 uuf; ± 0.5 uuf load capacitance; fundamental operation; type HC-6/U holder.	CR-109-38
Y3409	CRYSTAL UNIT, QUARTZ: 3.000000 mc, $\pm .001\%$; 0° to +50°C operating temperature range; parallel resonance; 10 uuf; ± 0.5 uuf load capacitance; fundamental operation; type HC-6/U holder.	CR-109-37
Y3410	CRYSTAL UNIT, QUARTZ: 2.900000 mc, $\pm .001\%$, 0° to +50°C operating temperature range; parallel resonance; 10 uuf; ± 0.5 uuf load capacitance; fundamental operation; type HC-6/U holder.	CR-109-36

1 MC SELECTOR DECK

C3501	CAPACITOR, VARIABLE, GLASS DIELECTRIC: 1 to 30 uuf; $\pm 100\%$; 1000 VDCW.	CV-108-4
C3502 thru C3508	Same as C3501.	
C3509	CAPACITOR, VARIABLE, GLASS DIELECTRIC: 0.8 to 18 uuf; $\pm 100\%$; 1000 VDCW.	CV-108-3
C3510 thru C3516	Same as C3509.	
C3517	CAPACITOR, VARIABLE, GLASS DIELECTRIC: 0.7 to 12 uuf; $\pm 75\%$, 1000 VDCW.	CV-108-2
C3518 thru C3530	Same as C3517.	
C3531	CAPACITOR, FIXED, MICA DIELECTRIC: 5 uuf; $\pm 5\%$; 500 VDCW.	CM15B050J
C3532 thru C3560	Same as C3531.	
C3561	CAPACITOR, FIXED, MICA DIELECTRIC: 470 uuf; $\pm 5\%$; 500 VDCW.	CM15B471J
C3562	CAPACITOR, FIXED, MICA DIELECTRIC: 24 uuf; $\pm 5\%$; 500 VDCW.	CM15B240J
C3563	CAPACITOR, FIXED, CERAMIC DIELECTRIC: 100,000 uuf; 80% -20%; 500 VDCW.	CC-100-32

PARTS LIST (CONT'D)

1 MC SELECTOR DECK

REF SYMBOL	DESCRIPTION	TMC PART NUMBER
C3564	Same as C3563.	
C3565	Same as C3563.	
C3566	CAPACITOR, FIXED, CERAMIC DI-ELECTRIC: 20,000 uuf; +80% -20%; 500 VDCW	CC-100-24
C3567	Same as C3563.	
C3568	Same as C3566.	
C3569	CAPACITOR, FIXED, CERAMIC DI-ELECTRIC: 10,000 uuf; GMV; 500 VDCW.	CC-100-16
C3570	NOT USED	
C3571	CAPACITOR, FIXED, CERAMIC DI-ELECTRIC: 1000 uuf; ±10%; 500 VDCW.	CC-100-9
C3572	Same as C3571.	
C3573	Same as C3471.	
C3574	CAPACITOR, FIXED, MICA DIELECTRIC: 10 uuf; ±5%; 500 VDCW.	CM15B100J
C3575	CAPACITOR, FIXED, MICA DIELECTRIC: 2000 uuf; ±10%; 300 VDCW.	CM112C202K3S
C3576	Same as C3566.	
C3577	Same as C3569.	
C3578	Same as C3571.	
C3579	CAPACITOR, FIXED, CERAMIC DI-ELECTRIC: 02 uuf; ±0.5 uuf; 500 VDCW.	CC21SL020D
C3580	CAPACITOR, FIXED, MICA DIELECTRIC: 20 uuf; ±5%; 500 VDCW.	CM15B200J
C3581	Same as C3509.	
C3582	Same as C3509.	
C3583	Same as C3571.	
C3584	Same as C3569.	
C3585	Same as C3575.	
C3586	Same as C3571.	
C3587	Same as C3580.	
C3588	Same as C3509.	
C3589	Same as C3579.	

PARTS LIST (CONT'D)

1 MC SELECTOR DECK

REF SYMBOL	DESCRIPTION	TMC PART NUMBER
C3590	Same as C3509.	
C3591	Same as C3571.	
C3592	Same as C3575.	
C3593	Same as C3509.	
C3594	Same as C3531.	
C3595	Same as C3579.	
C3596	Same as C3569.	
C3597	Same as C3580.	
C3598	Same as C3571.	
C3599	NOT USED	
C3600	CAPACITOR, FIXED, MICA DIELEC- TRIC: 39 uuf; ±5%; 500 VDCW.	CM15B390J
C3601	CAPACITOR, FIXED, MICA DIELEC- TRIC: 47 uuf; ±5%; 500 VDCW.	CM15B470J
C3602	Same as C3566.	
C3603	Same as C3563.	
C3604	Same as C3566.	
C3605	Same as C3566.	
C3606	CAPACITOR, FIXED, MICA DIELEC- TRIC: 27 uuf; ±5%; 500 VDCW.	CM15B270J
C3607	Same as C3561.	
C3608	Same as C3566.	
C3609	Same as C3563.	
C3610	CAPACITOR, FIXED, MICA DIELEC- TRIC: 33 uuf; ±5%; 500 VDCW.	CM15B330J
C3611	Same as C3569.	
C3612	Same as C3569.	
C3613	Same as C3571.	
C3614	Same as C3571.	
C3615	Same as C3569.	
C3616	CAPACITOR, FIXED, MICA DIELEC- TRIC: 91 uuf; ±5%; 500 VDCW.	CM15B910J
C3617	Same as C3571.	
C3618	Same as C3571.	

PARTS LIST (CONT'D)

1 MC SELECTOR DECK

REF SYMBOL	DESCRIPTION	TMC PART NUMBER	
C3619	Same as C3569.	CM15B220J	
C3620	Same as C3575.		
C3621	CAPACITOR, FIXED, MICA DIELEC- TRIC: 22 uuf; $\pm 5\%$; 500 VDCW.		
C3622	Same as C3621.		
C3623	Same as C3509.		
C3624	Same as C3571.		
C3625	Same as C3571.		
C3626	Same as C3575.		
C3627	Same as C3621.		
C3628	Same as C3509.		
C3629	Same as C3621.		
C3630	Same as C3571.		
C3631	Same as C3571.		
C3632	Same as C3575.		
C3633	Same as C3571.		
C3634	CAPACITOR, FIXED, MICA DIELEC- TRIC: 15 uuf; $\pm 5\%$; 500 VDCW.		CM15B150J
C3635	Same as C3509.		
C3636	Same as C3531.		
C3637	Same as C3580.		
C3638 thru C3640	Same as C3566.		
C3641	NOT USED		
C3642	Same as C3531.		
C3643	Same as C3634.		
C3644	CAPACITOR, FIXED, MICA DIELEC- TRIC: 200 uuf; $\pm 5\%$; 500 VDCW.	CM15B201J	
C3645	Same as C3571.		
C3646	Same as C3531.		
J3501	CONNECTOR, RECEPTACLE, ELEC- TRICAL: RF type; 1 round male contact; straight type; series BNC to BNC.	JJ-211	

PARTS LIST (CONT'D)

1 MC SELECTOR DECK

REF SYMBOL	DESCRIPTION	TMC PART NUMBER
J3502 thru J3505	Same as J3501.	
J3506	CONNECTOR, RECEPTACLE, ELECTRICAL: 7 round #16 male contacts; straight type.	JJ-245
J3507	CONNECTOR, RECEPTACLE, ELECTRICAL: 14 round #20 female contacts; straight type.	JJ-242-3S
J3508	Same as J3507.	
L3501	COIL, RADIO FREQUENCY: fixed; 0.68 uh, $\pm 20\%$; 0.08 ohms dc resistance; molded case.	CL-270-0.68
L3502	COIL, RADIO FREQUENCY: fixed, 48 to 78 mc; 0.17 uh ± 0.03 uh at 25.2 mc; phenolic.	CL-309
L3503	COIL, RADIO FREQUENCY: fixed; 2.5 mh; $\pm 10\%$; 26 ohms dc resistance; 100 ma current rating; molded case.	CL-140-1
L3504	COIL, RADIO FREQUENCY: fixed; .150 mh, $\pm 10\%$; 4.0 ohms dc resistance; 100 ma current rating; molded case.	CL-140-2
L3505.1	CORE, TOROID: bead type; powder iron.	CI-120-1
L3505.2 thru L3505.6	Same as L3505.1.	
L3506	Same as L3503.	
L3507	COIL, RADIO FREQUENCY: fixed; 8.2 uh; 2.10 ohms dc resistance.	CL-240-8.2
L3508	Same as L3507.	
L3509	COIL, RADIO FREQUENCY: fixed; 40.5 mc, ± 1 mc; 1 amp current rating.	CL-293
L3510.1 thru L3510.6	Same as L3505.1.	
L3511.1 thru L3511.6	Same as L3505.1.	
L3512.1 thru L3512.6	Same as L3505.1.	
L3513	Same as L3507.	

PARTS LIST (CONT'D)

1 MC SELECTOR DECK

REF SYMBOL	DESCRIPTION	TMC PART NUMBER
L3514.1 thru L3514.6	Same as L3505.1.	
L3515	Same as L3504.	
L3516	Same as L3504.	
L3517	Same as L3503.	
L3518.1 thru L3518.6	Same as L3505.1.	
L3519.1 thru L3519.6	Same as L3505.1.	
L3520	COIL, RADIO FREQUENCY: fixed; .65 uh, ±10%; 1/2 ohm dc resistance; 10 amp current rating; 44 mc operating frequency.	CL-295
L3521.1 thru L3521.6	Same as L3505.1.	
L3522	Same as L3509.	
L3523	Same as L3503.	
L3524	Same as L3503.	
L3525	Same as L3507.	
L3526	COIL, RADIO FREQUENCY: fixed; 47.0 uh, ±10%; 2.3 ohms dc resistance.	CL-240-47
L3527	COIL, RADIO FREQUENCY: fixed; 22.0 uh; ±10%; 0.9 ohms dc resistance.	CL-240-22
L3528	Same as L3509.	
L3529.1 thru L3529.6	Same as L3505.1.	
L3530.1 thru L3530.6	Same as L3505.1.	
L3531.1 thru L3531.6	Same as L3505.1.	
L3532.1 thru L3532.6	Same as L3505.1.	
PS3501	SUPPRESSOR, PARASITIC: 5 turns no. 22 wire on 47 ohm, 1/2 watt resistor.	AX-163

PARTS LIST (CONT'D)

1 MC SELECTOR DECK

REF SYMBOL	DESCRIPTION	TMC PART NUMBER
PS3502 thru PS3508	Same as PS3501.	
R3501	RESISTOR, FIXED, COMPOSITION: 180 ohms; $\pm 10\%$; 1/2 watt.	RC20GF181K
R3502	Same as R3501.	
R3503	RESISTOR, FIXED, COMPOSITION: 2200 ohms; $\pm 10\%$; 1/2 watt.	RC20GF222K
R3504	Same as R3503.	
R3505	Same as R3503.	
R3506	RESISTOR, FIXED, COMPOSITION: 330,000 ohms; $\pm 10\%$; 1/2 watt.	RC20GF334K
R3507	RESISTOR, FIXED, COMPOSITION: 47,000 ohms; $\pm 10\%$; 1/2 watt.	RC20GF473K
R3508	RESISTOR, FIXED, COMPOSITION: 22,000 ohms; $\pm 10\%$; 1/2 watt.	RC20GF223K
R3509	RESISTOR, FIXED, COMPOSITION: 3300 ohms; $\pm 10\%$; 1/2 watt.	RC20GF332K
R3510	RESISTOR, FIXED, COMPOSITION: 47 ohms; $\pm 10\%$; 1/2 watt.	RC20GF470K
R3511	RESISTOR, FIXED, COMPOSITION: 3900 ohms; $\pm 10\%$; 1/2 watt.	RC20GF392K
R3512	RESISTOR, FIXED, COMPOSITION: 1500 ohms; $\pm 10\%$; 1/2 watt.	RC20GF152K
R3513	Same as R3511.	
R3514	RESISTOR, FIXED, COMPOSITION: 33,000 ohms; $\pm 10\%$; 1/2 watt.	RC20GF333K
R3515	Same as R3501.	
R3516	RESISTOR, FIXED, COMPOSITION: 4700 ohms; $\pm 10\%$; 1/2 watt.	RC20GF472K
R3517	Same as R3514.	
R3518	Same as R3516.	
R3519	RESISTOR, FIXED, COMPOSITION: 10,000 ohms; $\pm 10\%$; 1/2 watt.	RC20GF103K
R3520	Same as R3501.	
R3521	Same as R3511.	
R3522	RESISTOR, FIXED, COMPOSITION: 8200 ohms; $\pm 10\%$; 1/2 watt.	RC20GF822K

PARTS LIST (CONT'D)

1 MC SELECTOR DECK

REF SYMBOL	DESCRIPTION	TMC PART NUMBER
R3523	RESISTOR, FIXED, COMPOSITION: 1000 ohms; ±10%; 1/2 watt.	RC20GF102K
R3524	RESISTOR, FIXED, COMPOSITION: 150 ohms; ±10%; 1/2 watt.	RC20GF151K
R3525	Same as R3508.	
R3526	RESISTOR, FIXED, COMPOSITION: 12,000 ohms; ±10%; 1 watt.	RC32GF123K
R3527	RESISTOR, FIXED, COMPOSITION: 1.0 megohms; ±10%; 1/2 watt.	RC20GF105K
R3528	RESISTOR, FIXED, COMPOSITION: 120,000 ohms; ±10%; 1/2 watt.	RC20GF124K
R3529	Same as R3510.	
R3530	Same as R3524.	
R3531	RESISTOR, FIXED, COMPOSITION: 68,000 ohms; ±10%; 1/2 watt.	RC20GF683K
R3532	Same as R3501.	
R3533	RESISTOR, FIXED, COMPOSITION: 330 ohms; ±10%; 1/2 watt.	RC20GF331K
R3534	Same as R3516.	
R3535	Same as R3514.	
R3536	RESISTOR, FIXED, COMPOSITION: 10 ohms; ±10%; 1/2 watt.	RC20GF100K
R3537	Same as R3519.	
R3538	Same as R3519.	
R3539	RESISTOR, FIXED, COMPOSITION: 820,000 ohms; ±10%; 1/2 watt.	RC20GF824K
R3540	Same as R3531.	
R3541	Same as R3509.	
R3542	Same as R3524.	
R3543	Same as R3514.	
R3544	Same as R3506.	
R3545	Same as R3501.	
R3546	Same as R3516.	
R3547	Same as R3506.	
R3548	Same as R3514.	
R3549	Same as R3516.	

PARTS LIST (CONT'D)

1 MC SELECTOR DECK

REF SYMBOL	DESCRIPTION	TMC PART NUMBER
R3550	Same as R3501.	
R3551	RESISTOR, FIXED, COMPOSITION: 27,000 ohms; $\pm 10\%$; 1/2 watt.	RC20GF273K
R3552	Same as R3503.	
R3553	Same as R3524.	
R3554	Same as R3510.	
R3555	Same as R3511.	
R3556 thru R3558	Same as R3508.	
R3559	Same as R3510.	
S3501 A, B C, D	SWITCH, ROTARY: 4 section; 32 positions; shorting type contacts; contact rating, 2 amps, 125 vac.	SW-300
T3501	TRANSFORMER, RADIO FREQUENCY: fixed, 43 mc operating frequency; primary inductance .65 mh; $\pm 10\%$; secondary inductance .60 mh, $\pm 10\%$.	AT-104
T3502	Same as T3501.	
T3503	TRANSFORMER, RADIO FREQUENCY: tuned; 2 mc operating frequency; primary inductance 140 uuf, $\pm 10\%$; consists of one 12 uuf capacitor in primary.	TT-176
T3504	TRANSFORMER, RADIO FREQUENCY: tuned; 3.25 to 4.25 mc operating frequency range; primary inductance 30.0 uh; consists of one 27,000 ohm 1/2 watt resistor and one 30 uuf capacitor in primary.	TT-178
T3505	TRANSFORMER, RADIO FREQUENCY: tuned; 1 mc operating frequency; primary inductance 140 uh; $\pm 10\%$; consists of 100 uuf capacitor in primary.	TT-175
TP3501	TERMINAL, FEEDTHRU, INSULATED: 0.740" lg. x 3/16" dia. ; 3/32 press-fit stad; teflon insulated 2000 v.	TE-169-1
TP3502 thru TP3509	Same as TP3501.	
V3501 A, B	TUBE, ELECTRON: high-mu triode sharp-cutoff pentode; 9 pin miniature.	6AW8
V3502	TUBE, ELECTRON: sharp-cutoff pentode; 7 pin miniature.	6EW6

PARTS LIST (CONT'D)

1 MC SELECTOR DECK

REF SYMBOL	DESCRIPTION	TMC PART NUMBER
V3503	TUBE, ELECTRON: high-mu triode; 7 pin miniature.	6AB4
V3504	TUBE, ELECTRON: sharp-cutoff pentode; 7 pin miniature.	6AK5
V3505	TUBE, ELECTRON: medium-mu triode; 9 pin miniature.	6S4
V3506 thru V3510	Same as V3504.	
V3511	TUBE, ELECTRON: pentagrid converter; 7 pin miniature.	6BE6
V3512	TUBE, ELECTRON: sharp-cutoff pentode; 7 pin miniature.	6AU6
XV3501	SOCKET, ELECTRON TUBE: 9 pin miniature.	TS103P01
XV3502	SOCKET, ELECTRON TUBE: 7 pin miniature.	TS102P01
XV3503	Same as XV3502.	
XV3504	Same as XV3502.	
XV3505	Same as XV3501.	
XV3506 thru XV3512	Same as XV3502.	
XY3501 A, B	JACK, TIP: nominal RMS voltage at 60 cps, 750 v; 0.5 uuf; with white teflon body.	JJ-219-18-9
XY3502 A, B thru XY3530 A, B	Same as XY3501A, B.	
Y3501	CRYSTAL UNIT, QUARTZ: 48.500 mc, $\pm 0.05\%$; 0° to +50°C operating temperature range; parallel resonance; 10 uuf, ± 20 uuf load capacitance; fundamental operation; type HC-18/U holder.	CR-109-46
Y3502	CRYSTAL UNIT, QUARTZ: 49.500 mc, $\pm 0.05\%$; 0° to +50°C operating temperature range; parallel resonance; 10 uuf, ± 20 uuf load capacitance; fundamental operation; type HC-18/U holder.	CR-109-47
Y3503	CRYSTAL UNIT, QUARTZ: 50.500 mc, $\pm 0.05\%$; 0° to +50°C operating temperature range; parallel resonance; 10 uuf, ± 20 uuf load capacitance; fundamental operation; type HC-18/U holder.	CR-109-48

PARTS LIST (CONT'D)

1 MC SELECTOR DECK

REF SYMBOL	DESCRIPTION	TMC PART NUMBER
Y3504	CRYSTAL UNIT, QUARTZ: 51.500 mc, $\pm .05\%$; 0° to +50°C operating temperature range; parallel resonance; 10 uuf, ± 20 uuf load capacitance; fundamental operation; type HC-18/U holder.	CR-109-49
Y3505	CRYSTAL UNIT, QUARTZ: 52.500 mc, $\pm .05\%$; 0° to +50°C operating temperature range; parallel resonance; 10 uuf, ± 20 uuf load capacitance; fundamental operation; type HC-18/U holder.	CR-109-50
Y3506	CRYSTAL UNIT, QUARTZ: 53.500 mc, $\pm .05\%$; 0° to +50°C operating temperature range; parallel resonance; 10 uuf, ± 20 uuf load capacitance; fundamental operation; type HC-18/U holder.	CR-109-51
Y3507	CRYSTAL UNIT, QUARTZ: 54.500 mc, $\pm .05\%$; 0° to +50°C operating temperature range; parallel resonance; 10 uuf, ± 20 uuf load capacitance; fundamental operation; type HC-18/U holder.	CR-109-52
Y3508	CRYSTAL UNIT, QUARTZ: 55.500 mc, $\pm .05\%$; 0° to +50°C operating temperature range; parallel resonance; 10 uuf, ± 20 uuf load capacitance; fundamental operation; type HC-18/U holder.	CR-109-53
Y3509	CRYSTAL UNIT, QUARTZ: 56.500 mc $\pm .05\%$; 0° to +50°C operating temperature range; parallel resonance; 10 uuf, ± 20 uuf load capacitance; fundamental operation; type HC-18/U holder.	CR-109-54
Y3510	CRYSTAL UNIT, QUARTZ: 57.500 mc, $\pm .05\%$; 0° to +50°C operating temperature range; parallel resonance; 10 uuf, ± 20 uuf load capacitance; fundamental operation; type HC-18/U holder.	CR-109-55
Y3511	CRYSTAL UNIT, QUARTZ: 58.500 mc, $\pm .05\%$; 0° to +50°C operating temperature range; parallel resonance; 10 uuf, ± 20 uuf load capacitance; fundamental operation; type HC-18/U holder.	CR-109-56
Y3512	CRYSTAL UNIT, QUARTZ: 59.500 mc, $\pm .05\%$; 0° to +50°C operating temperature range; parallel resonance; 10 uuf, ± 20 uuf load capacitance; fundamental operation, type HC-18/U holder.	CR-109-57
Y3513	CRYSTAL UNIT, QUARTZ: 60.500 mc, $\pm .05\%$; 0° to +50°C operating temperature range; parallel resonance; 10 uuf, ± 20 uuf load capacitance; fundamental operation, type HC-18/U holder.	CR-109-58

PARTS LIST (CONT'D)

1 MC SELECTOR DECK

REF SYMBOL	DESCRIPTION	TMC PART NUMBER
Y3514	CRYSTAL UNIT, QUARTZ: 61.500 mc, $\pm 0.05\%$; 0° to $+50^\circ\text{C}$ operating temperature range; parallel resonance; 10 uuf, ± 20 uuf load capacitance; fundamental operation; type HC-18/U holder.	CR-109-59
Y3515	CRYSTAL UNIT, QUARTZ: 62.500 mc, $\pm 0.05\%$; 0° to $+50^\circ\text{C}$ operating temperature range; parallel resonance; 10 uuf, ± 20 uuf load capacitance; fundamental operation; type HC-18/U holder.	CR-109-60
Y3516	CRYSTAL UNIT, QUARTZ: 63.500 mc, $\pm 0.05\%$; 0° to $+50^\circ\text{C}$ operating temperature range; parallel resonance; 10 uuf, ± 20 uuf load capacitance; fundamental operation; type HC-18/U holder.	CR-109-61
Y3517	CRYSTAL UNIT, QUARTZ: 64.500 mc, $\pm 0.05\%$; 0° to $+50^\circ\text{C}$ operating temperature range; parallel resonance; 10 uuf, ± 20 uuf load capacitance; fundamental operation; type HC-18/U holder.	CR-109-62
Y3518	CRYSTAL UNIT, QUARTZ: 65.500 mc, $\pm 0.05\%$; 0° to $+50^\circ\text{C}$ operating temperature range; parallel resonance; 10 uuf, ± 20 uuf load capacitance; fundamental operation; type HC-18/U holder.	CR-109-63
Y3519	CRYSTAL UNIT, QUARTZ: 66.500 mc, $\pm 0.05\%$; 0° to $+50^\circ\text{C}$ operating temperature range; parallel resonance; 10 uuf, ± 20 uuf load capacitance; fundamental operation; type HC-18/U holder.	CR-109-64
Y3520	CRYSTAL UNIT, QUARTZ: 67.500 mc, $\pm 0.05\%$; 0° to $+50^\circ\text{C}$ operating temperature range; parallel resonance; 10 uuf, ± 20 uuf load capacitance; fundamental operation; type HC-18/U holder.	CR-109-65
Y3521	CRYSTAL UNIT, QUARTZ: 68.500 mc, $\pm 0.05\%$; 0° to $+50^\circ\text{C}$ operating temperature range; parallel resonance; 10 uuf, ± 20 uuf load capacitance; fundamental operation; type HC-18/U holder.	CR-109-66
Y3522	CRYSTAL UNIT, QUARTZ: 69.500 mc, $\pm 0.05\%$; 0° to $+50^\circ\text{C}$ operating temperature range; parallel resonance; 10 uuf, ± 20 uuf load capacitance; fundamental operation; type HC-18/U holder.	CR-109-67
Y3523	CRYSTAL UNIT, QUARTZ: 70.500 mc, $\pm 0.05\%$; 0° to $+50^\circ\text{C}$ operating temperature range; parallel resonance; 10 uuf, ± 20 uuf load capacitance; fundamental operation; type HC-18/U holder.	CR-109-68

PARTS LIST (CONT'D)

1 MC SELECTOR DECK

REF SYMBOL	DESCRIPTION	TMC PART NUMBER
Y3524	CRYSTAL UNIT, QUARTZ: 71.500 mc, $\pm .05\%$; 0° to +50° C operating temperature range; parallel resonance; 10 uuf, ± 20 uuf load capacitance; fundamental operation; type HC-18/U holder.	CR-109-69
Y3525	CRYSTAL UNIT, QUARTZ: 72.500 mc, $\pm .05\%$; 0° to +50° C operating temperature range; parallel resonance; 10 uuf; ± 20 uuf load capacitance; fundamental operation; type HC-18/U holder.	CR-109-70
Y3526	CRYSTAL UNIT, QUARTZ: 73.500 mc, $\pm .05\%$; 0° to +50° C operating temperature range; parallel resonance; 10 uuf; ± 20 uuf load capacitance; fundamental operation; type HC-18/U holder.	CR-109-71
Y3527	CRYSTAL UNIT, QUARTZ: 74.500 mc, $\pm .05\%$; 0° to +50° C operating temperature range; parallel resonance; 10 uuf; ± 20 uuf load capacitance; fundamental operation; type HC-18/U holder.	CR-109-72
Y3528	CRYSTAL UNIT, QUARTZ: 75.500 mc, $\pm .05\%$; 0° to +50° C operating temperature range; parallel resonance; 10 uuf; ± 20 uuf load capacitance; fundamental operation; type HC-18/U holder.	CR-109-73
Y3529	CRYSTAL UNIT, QUARTZ: 76.500 mc, $\pm .05\%$; 0° to +50° C operating temperature range; parallel resonance; 10 uuf; ± 20 uuf load capacitance; fundamental operation; type HC-18/U holder.	CR-109-74
Y3530	CRYSTAL UNIT, QUARTZ: 77.500 mc, $\pm .05\%$; 0° to +50° C operating temperature range; parallel resonance; 10 uuf; ± 20 uuf load capacitance; fundamental operation; type HC-18/U holder.	CR-109-75
Z3501	FILTER, LOWPASS: cutoff frequency 33.75 mc; input impedance 50 ohms; output impedance 50 ohms; hermetically sealed metal case.	FX-179
Z3502	FILTER, LOWPASS: cutoff frequency 37 mc; input impedance 150 ohms; output impedance 150 ohms; hermetically sealed metal case.	FX-180

REGENERATIVE DIVIDER

C3701	CAPACITOR, FIXED, CERAMIC DIELECTRIC: 10,000 uuf; GMC; 500 VDCW.	CC-100-16
C3702	Same as C3701.	

PARTS LIST (CONT'D)

REGENERATIVE DIVIDER

REF SYMBOL	DESCRIPTION	TMC PART NUMBER
C3703	CAPACITOR, FIXED, PAPER DIELECTRIC: mylar type; 100,000 uuf; $\pm 20\%$; 300 VDCW.	CN106D104M
C3704	CAPACITOR, FIXED, CERAMIC DIELECTRIC: 100,000 uuf; $+80\%$ -20% ; 100 VDCW.	CC-100-28
C3705	Same as C3703.	
C3706	Same as C3703.	
C3707	CAPACITOR, FIXED, CERAMIC DIELECTRIC: 20,000 uuf; $+80\%$ -20% ; 500 VDCW.	CC-100-24
C3708	CAPACITOR, FIXED, MICA DIELECTRIC: 300 uuf, $\pm 5\%$; 500 VDCW.	CM15B301J
C3709	Same as C3703.	
C3710	Same as C3707.	
C3711	CAPACITOR, FIXED, MICA DIELECTRIC: 10 uuf; $\pm 10\%$; 500 VDCW.	CM15B100K
C3712	Same as C3703.	
C3713	Same as C3703.	
C3714	CAPACITOR, FIXED, CERAMIC DIELECTRIC: 100,000 uuf; $+80\%$ -20% ; 300 VDCW.	CC-100-37
J3701	CONNECTOR, RECEPTACLE, ELECTRICAL: RF type; 1 round male contact; straight type; series BNC to BNC.	JJ-211
J3702	Same as J3701.	
L3701	COIL, RADIO FREQUENCY: molded; 100 ma; 2.5 mh; $\pm 10\%$.	CL-140-1
L3702	COIL, RADIO FREQUENCY: tuned; 250 kc operating frequency; includes one 680 uuf capacitor.	AC-125
L3703	COIL, RADIO FREQUENCY: tuned; 750 kc operating frequency; includes one 3000 uuf capacitor.	AC-127
L3704	COIL, RADIO FREQUENCY: tuned; 250 kc operating frequency; includes two capacitors, one 680 uuf and 3000 uuf.	AC-126
L3705.1	CORE, TOROID: bead type; power iron.	CI-120-1
L3705.2 thru L3705.6	Same as L3705.1.	

PARTS LIST (CONT'D)

REGENERATIVE DIVIDER

REF SYMBOL	DESCRIPTION	TMC PART NUMBER
L3706.1 thru L3706.6	Same as C3705.1.	
L3707.1 thru L3707.6	Same as L3705.1.	
L3708.1 thru L3708.6	Same as L3705.1.	
L3709.1 thru L3709.6	Same as L3705.1.	
L3710.1 thru L3710.6	Same as L3705.1.	
P3701	CONNECTOR, PLUG, ELECTRICAL: 5 round #16 male contacts; straight type.	PL-225-1P
R3701	RESISTOR, FIXED, COMPOSITION: 100,000 ohms; $\pm 10\%$; 1/2 watt.	RC20GF104K
R3702	RESISTOR, FIXED, COMPOSITION: 680 ohms; $\pm 10\%$; 1/2 watt.	RC20GF681K
R3703	RESISTOR, FIXED, COMPOSITION: 6800 ohms; $\pm 10\%$; 1/2 watt.	RC20GF682K
R3704	RESISTOR, FIXED, COMPOSITION: 2200 ohms; $\pm 5\%$; 1/2 watt.	RC20GF222J
R3705	RESISTOR, FIXED, COMPOSITION: 22,000 ohms; $\pm 10\%$; 1/2 watt.	RC20GF223K
R3706	RESISTOR, FIXED, COMPOSITION: 150 ohms; $\pm 10\%$; 1/2 watt.	RC20GF151K
R3707	Same as R3701.	
R3708	RESISTOR, FIXED, COMPOSITION: 12,000 ohms; $\pm 10\%$; 1 watt.	RC32GF123K
R3709	RESISTOR, FIXED, COMPOSITION: 8200 ohms; $\pm 10\%$; 1/2 watt.	RC20GF822K
R3710	RESISTOR, FIXED, COMPOSITION: 330,000 ohms; $\pm 10\%$; 1/2 watt.	RC20GF334K
R3711	Same as R3702.	
R3712	RESISTOR, FIXED, COMPOSITION: 220 ohms; $\pm 10\%$; 1/2 watt.	RC20GF221K
R3713	Same as R3701.	
R3714	Same as R3712.	

PARTS LIST (CONT'D)

REGENERATIVE DIVIDER

REF SYMBOL	DESCRIPTION	TMC PART NUMBER
R3715	RESISTOR, FIXED, COMPOSITION: 33,000 ohms; ±10%; 1/2 watt.	RC20GF333K
R3716	RESISTOR, FIXED, COMPOSITION: 1000 ohms; ±10%; 1/2 watt.	RC20GF102K
T3701	TRANSFORMER, PULSE: 3 windings; winding no. 1, 4.7 mh; turns ratio 5:5:1.	TF-228-K15
TP3701	TERMINAL, FEEDTHRU, INSULATED: 0.740" lg x 3/16" dia; 3/32 press-fit stud; teflon insulated 2000 v.	TE-169-2
TP3702	Same as TP3701.	
V3701	TUBE, ELECTRON: high mu-triode; 7 pin miniature.	6AB4
V3702	TUBE, ELECTRON: pentagrid amplifier; 7 pin miniature.	6CS6
V3703 A, B	TUBE, ELECTRON: medium mu-triode sharp cutoff pentode; 9 pin miniature.	6U8A
XV3701	SOCKET, ELECTRON TUBE: 7 pin miniature.	TS102P01
XV3702	Same as XV3701.	
XV3703	SOCKET, ELECTRON TUBE: 9 pin miniature.	TS103P01

SECTION 8
SCHEMATIC DIAGRAMS

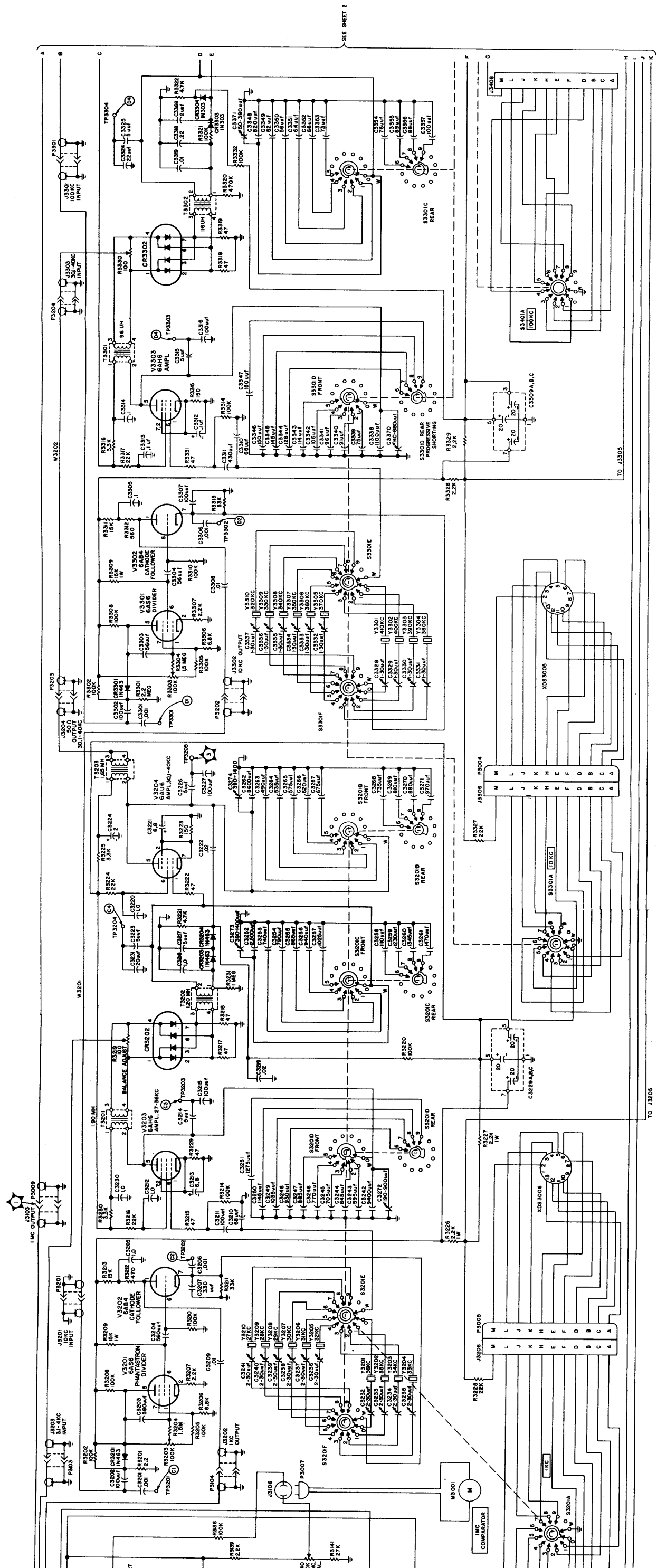
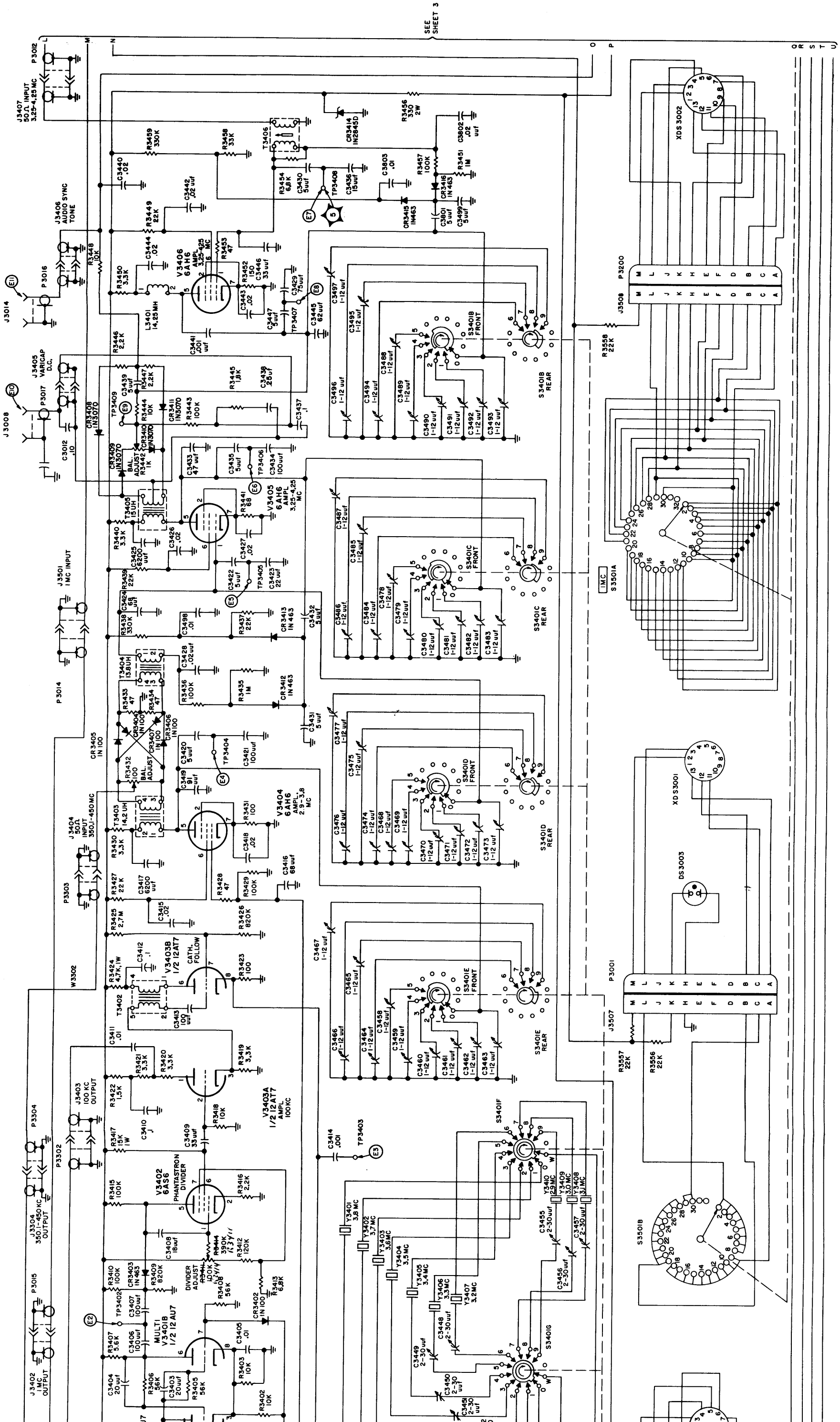


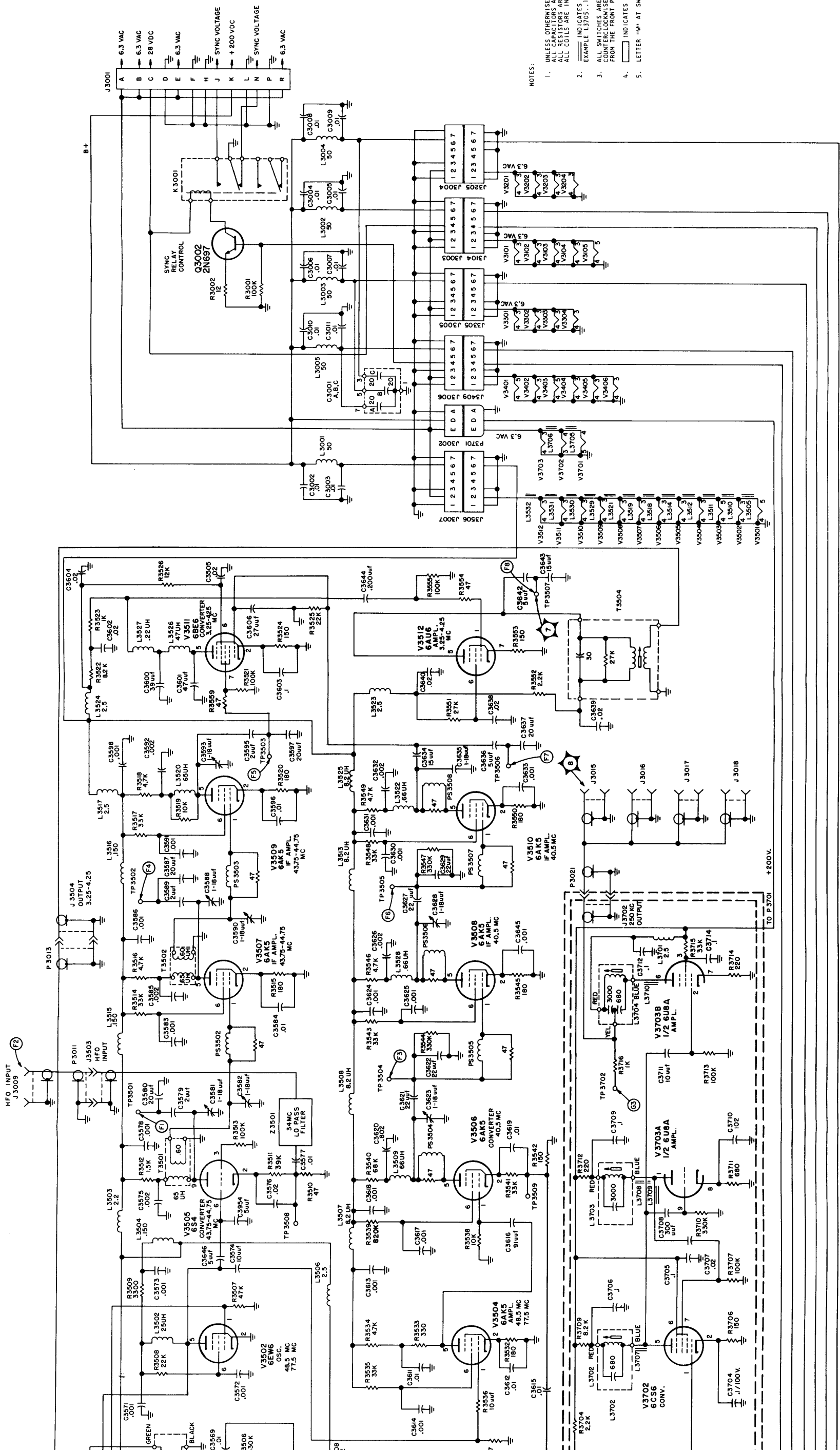
Figure 8-1. HFS-1 Schematic Diagram (Sheet 1 of 3)

8-3/8-4



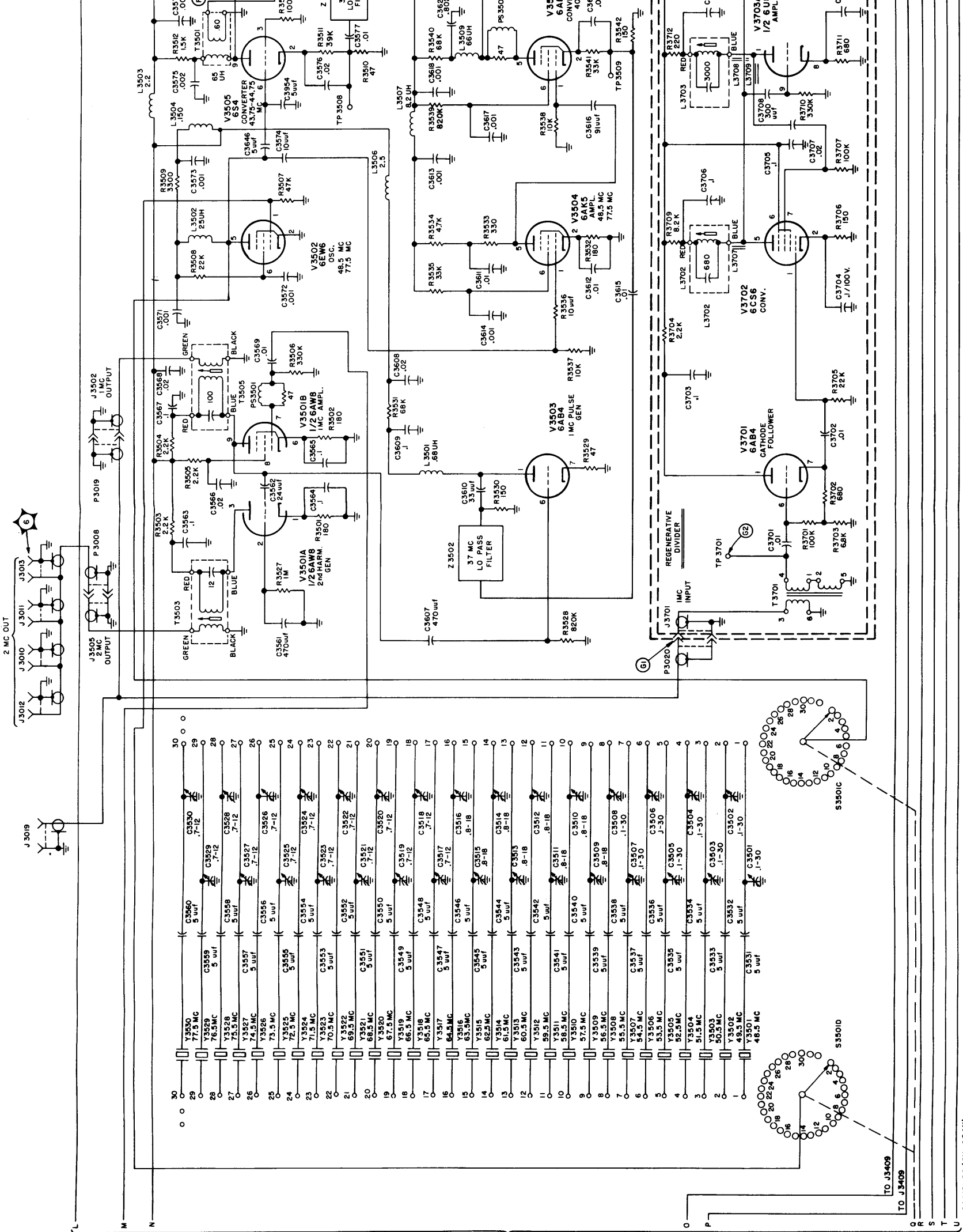
SEE SHEET 3

Figure 8-1. HFS-1 Schematic Diagram (Sheet 2 of 3)



- NOTES:
1. UNLESS OTHERWISE SPECIFIED ALL CAPACITORS ARE IN UF ALL RESISTORS ARE IN OHMS 1/2 WATT ALL COILS ARE IN MH
 2. EXAMPLE L3705-1, -2, -3, -4, -5, -6
 3. INDICATES 6 INDIVIDUAL BEADS
 4. ALL SWITCHES ARE SHOWN IN THEIR FULLY CENTERED OR NEUTRAL POSITIONS, AS VIEWED FROM THE FRONT PANEL.
 5. LETTER "M" AT SWITCH MEANS WIPER.

Figure 8-1. HFS-1 Schematic Diagram (Sheet 3 of 3)



30	V3530	77.5 MC	C3560	5 uF	7-12
29	V3529	77.5 MC	C3559	5 uF	7-12
28	V3528	76.5 MC	C3558	5 uF	7-12
27	V3527	75.5 MC	C3557	5 uF	7-12
26	V3526	74.5 MC	C3556	5 uF	7-12
25	V3525	73.5 MC	C3555	5 uF	7-12
24	V3524	72.5 MC	C3554	5 uF	7-12
23	V3523	71.5 MC	C3553	5 uF	7-12
22	V3522	70.5 MC	C3552	5 uF	7-12
21	V3521	69.5 MC	C3551	5 uF	7-12
20	V3520	68.5 MC	C3550	5 uF	7-12
19	V3519	67.5 MC	C3549	5 uF	7-12
18	V3518	66.5 MC	C3548	5 uF	7-12
17	V3517	65.5 MC	C3547	5 uF	7-12
16	V3516	64.5 MC	C3546	5 uF	7-12
15	V3515	63.5 MC	C3545	5 uF	8-18
14	V3514	62.5 MC	C3544	5 uF	8-18
13	V3513	61.5 MC	C3543	5 uF	8-18
12	V3512	60.5 MC	C3542	5 uF	8-18
11	V3511	59.5 MC	C3541	5 uF	8-18
10	V3510	58.5 MC	C3540	5 uF	8-18
9	V3509	57.5 MC	C3539	5 uF	8-18
8	V3508	56.5 MC	C3538	5 uF	8-18
7	V3507	55.5 MC	C3537	5 uF	11-30
6	V3506	54.5 MC	C3536	5 uF	11-30
5	V3505	53.5 MC	C3535	5 uF	11-30
4	V3504	52.5 MC	C3534	5 uF	11-30
3	V3503	51.5 MC	C3533	5 uF	11-30
2	V3502	50.5 MC	C3532	5 uF	11-30
1	V3501	49.5 MC	C3531	5 uF	11-30

SEE SHEET 2

TO J3409
TO J3409
300IB-28 (CK-604W)

109653001B