

200

UNCLASSIFIED

MASTER COPY

DO NOT DESTROY

TECHNICAL MANUAL

for

ANTENNA MULTICOUPLER

LMC-10

(O-714/UR)

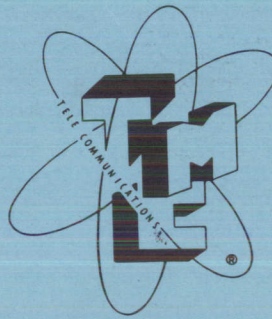

THE TECHNICAL MATERIEL CORPORATION
MAMARONECK, N.Y.

OTTAWA, ONTARIO

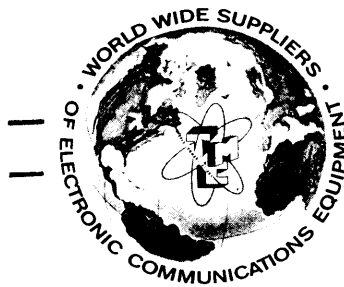

THE TECHNICAL MATERIEL CORPORATION

C O M M U N I C A T I O N S E N G I N E E R S

700 FENIMORE ROAD

MAMARONECK, N. Y.

W a r r a n t y

The Technical Materiel Corporation, hereinafter referred to as TMC, warrants the equipment (except electron tubes,*fuses, lamps, batteries and articles made of glass or other fragile or other expendable materials) purchased hereunder to be free from defect in materials and workmanship under normal use and service, when used for the purposes for which the same is designed, for a period of one year from the date of delivery F.O.B. factory. TMC further warrants that the equipment will perform in a manner equal to or better than published technical specifications as amended by any additions or corrections thereto accompanying the formal equipment offer.

TMC will replace or repair any such defective items, F.O.B. factory, which may fail within the stated warranty period, PROVIDED:

1. That any claim of defect under this warranty is made within sixty (60) days after discovery thereof and that inspection by TMC, if required, indicates the validity of such claim to TMC's satisfaction.
2. That the defect is not the result of damage incurred in shipment from or to the factory.
3. That the equipment has not been altered in any way either as to design or use whether by replacement parts not supplied or approved by TMC, or otherwise.
4. That any equipment or accessories furnished but not manufactured by TMC, or not of TMC design shall be subject only to such adjustments as TMC may obtain from the supplier thereof.

Electron tubes*furnished by TMC, but manufactured by others, bear only the warranty given by such other manufacturers. Electron tube warranty claims should be made directly to the manufacturer of such tubes.

TMC's obligation under this warranty is limited to the repair or replacement of defective parts with the exceptions noted above.

At TMC's option any defective part or equipment which fails within the warranty period shall be returned to TMC's factory for inspection, properly packed with shipping charges prepaid. No parts or equipment shall be returned to TMC, unless a return authorization is issued by TMC.

No warranties, express or implied, other than those specifically set forth herein shall be applicable to any equipment manufactured or furnished by TMC and the foregoing warranty shall constitute the Buyers sole right and remedy. In no event does TMC assume any liability for consequential damages, or for loss, damage or expense directly or indirectly arising from the use of TMC Products, or any inability to use them either separately or in combination with other equipment or materials or from any other cause.

*Electron tubes also include semi-conductor devices.

PROCEDURE FOR RETURN OF MATERIAL OR EQUIPMENT

Should it be necessary to return equipment or material for repair or replacement, whether within warranty or otherwise, a return authorization must be obtained from TMC prior to shipment. The request for return authorization should include the following information:

1. Model Number of Equipment.
2. Serial Number of Equipment.
3. TMC Part Number.
4. Nature of defect or cause of failure.
5. The contract or purchase order under which equipment was delivered.

PROCEDURE FOR ORDERING REPLACEMENT PARTS

When ordering replacement parts, the following information must be included in the order as applicable:

1. Quantity Required.
2. TMC Part Number.
3. Equipment in which used by TMC or Military Model Number.
4. Brief Description of the Item.
5. The *Crystal Frequency* if the order includes crystals.

PROCEDURE IN THE EVENT OF DAMAGE INCURRED IN SHIPMENT

TMC's Warranty specifically excludes damage incurred in shipment to or from the factory. In the event equipment is received in damaged condition, the carrier should be notified immediately. Claims for such damage should be filed with the carrier involved and not with TMC.

All correspondence pertaining to Warranty Claims, return, repair, or replacement and all material or equipment returned for repair or replacement, within Warranty or otherwise, should be addressed as follows:

THE TECHNICAL MATERIEL CORPORATION
Engineering Services Department
700 Fenimore Road
Mamaroneck, New York

TABLE OF CONTENTS

SECTION 1—GENERAL DESCRIPTION		SECTION 4—PRINCIPLES OF OPERATION (Cont.)			
Paragraph	Page	Paragraph	Page		
1-1.	Purpose and Basic Principles	1-0			
1-2.	Description of Unit	1-0			
1-3.	Reference Data	1-0			
SECTION 2—INSTALLATION		SECTION 5—TROUBLE-SHOOTING			
2-1.	Initial Inspection	2-1	5-1.	Introduction	5-0
2-2.	115-vs 230-Volt Power Supply Connections	2-1	5-2.	General Trouble-Shooting Procedure	5-0
2-3.	Installation Procedure	2-1	5-3.	Trouble-Shooting Based on Operational Procedure	5-0
2-4.	Initial Adjustment-Dynamic Checking Section	2-1	5-4.	Voltages	5-0
2-5.	Special Conditions.	2-3	5-5.	Trouble-Shooting Based on Circuit Sectionalization.	5-0
SECTION 3—OPERATOR'S SECTION		SECTION 6—MAINTENANCE			
3-1.	Operator's Instructions	3-0	6-1.	Introduction	6-0
3-2.	Operator's Maintenance.	3-0	6-2.	Preventive Maintenance.	6-0
			6-3.	Corrective Maintenance.	6-0
SECTION 4—PRINCIPLES OF OPERATION		SECTION 7—PARTS LIST			
4-1.	General	4-0			
4-2.	Input and Preamplifier Section	4-0			
4-3.	Output Distribution Section	4-0			
		SECTION 8—SCHEMATIC DIAGRAMS			

LIST OF ILLUSTRATIONS

SECTION 1—GENERAL DESCRIPTION

Figure		Page
1-1a.	Antenna Multicoupler LMC-10, Front Angle View	iv
1-1b.	Antenna Multicoupler LMC-10, Rear View	v
1-2.	Typical Insertion Gain Character- istics, LMC-10-70/U	1-3
1-3.	Typical Cross-Modulation Characteristics, LMC-10-70/U . .	1-3
1-4.	Typical Impedance Characteristics, LMC-10-70/U (Filter in).	1-4

SECTION 2—INSTALLATION

2-1.	Installation Diagram Showing 115- vs 230-Volt Power Supply Connections.	2-1
2-2.	Outline Dimensional Drawing, LMC-10	2-2

SECTION 3—OPERATOR'S SECTION

3-1.	Panel View of LMC-10 Showing Operating Controls.	3-1
------	---	-----

SECTION 4—PRINCIPLES OF OPERATION

4-1.	Block Diagram, Amplifier.	4-1
4-2.	Schematic Diagram, Amplifier Signal Input Section	4-2
4-3.	Schematic Diagram, Amplifier Preamplifier Section.	4-2

SECTION 4—PRINCIPLES OF OPERATION (Cont.)

Figure		Page
4-4.	Schematic Diagram, Output Dis- tribution Section Showing Typical Output Stage	4-3
4-5.	Schematic Diagram, Amplifier Dynamic Checking Station	4-4
4-6.	Schematic Diagram, Amplifier Power Input Section	4-5

SECTION 5—TROUBLE-SHOOTING

5-1.	Location Diagram of Major Elec- tronic Components, Amplifier, Top View	5-2
5-2.	Location Diagram of Major Elec- tronic Components, Amplifier, Bottom View	5-3
5-3.	Location Diagram of Major Elec- tronic Components, Power Supply, Top View	5-4

SECTION 6—MAINTENANCE

6-1.	Block Diagram, Preamplifier Alignment Setup	6-1
------	--	-----

SECTION 8—SCHEMATIC DIAGRAMS

8-1.	Schematic Diagram, Distributive Amplifier DA-101-70/U	8-3-8-4
8-2.	Schematic Diagram, Power Supply PS-7	8-5-8-6

LIST OF TABLES

SECTION 1—GENERAL DESCRIPTION

Table		Page
1-1.	Electrical Characteristics, Amplifier	1-1
1-2.	Electrical Characteristics, Power Supply	1-2
1-3.	Vacuum Tube and Diode Complement, Amplifier	1-2
1-4.	Diode Complement, Power Supply	1-2

SECTION 3—OPERATOR'S SECTION

Table		Page
3-1.	Equipment Control Designations . .	3-0

SECTION 5—TROUBLE-SHOOTING

5-1.	Tube Operating Voltages, Amplifier	5-1
5-2.	Output Voltages, Power Supply . .	5-1

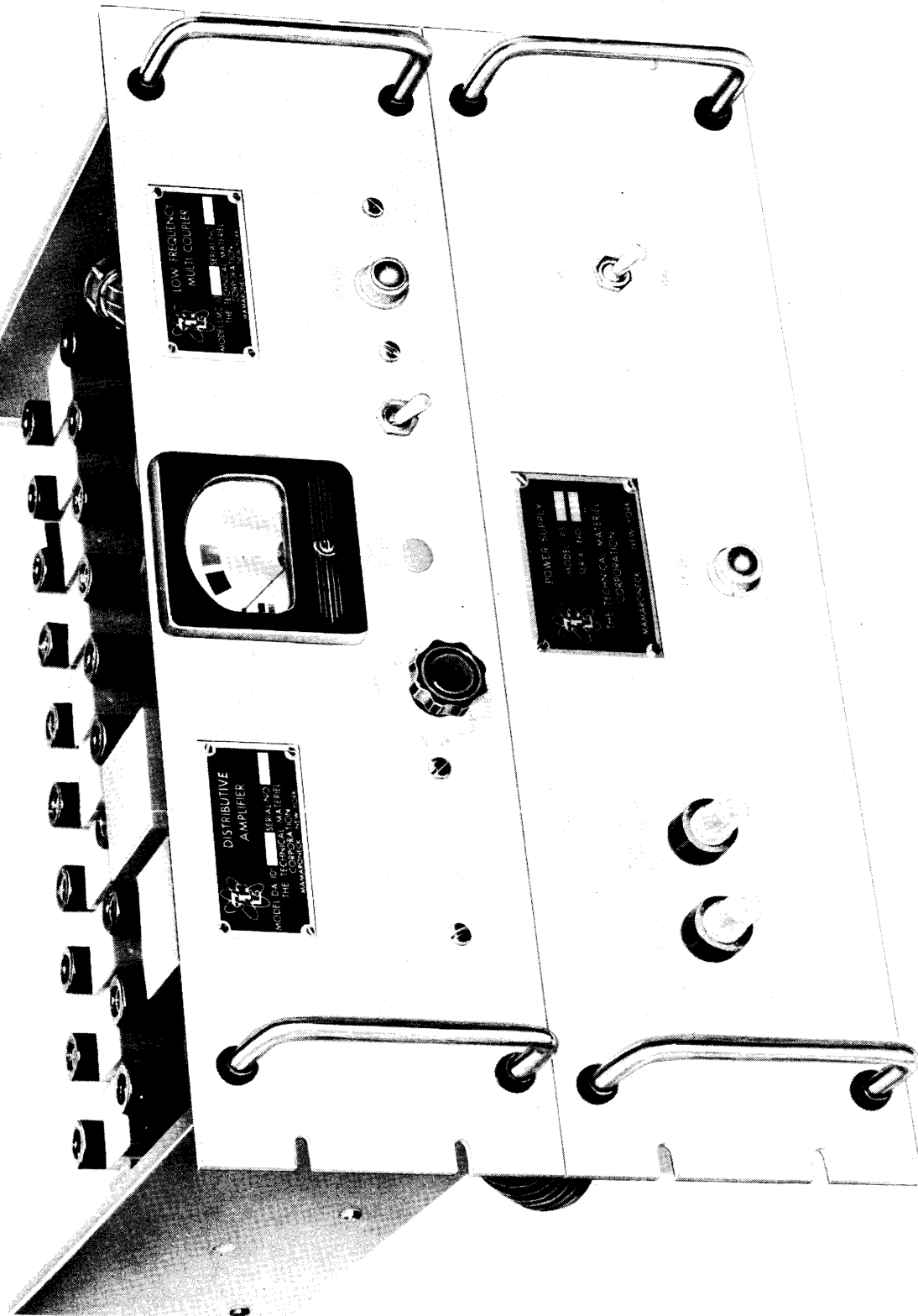

Figure 1-1a. Antenna Multicoupler LMC-10, Front Angle View

80-1A-1

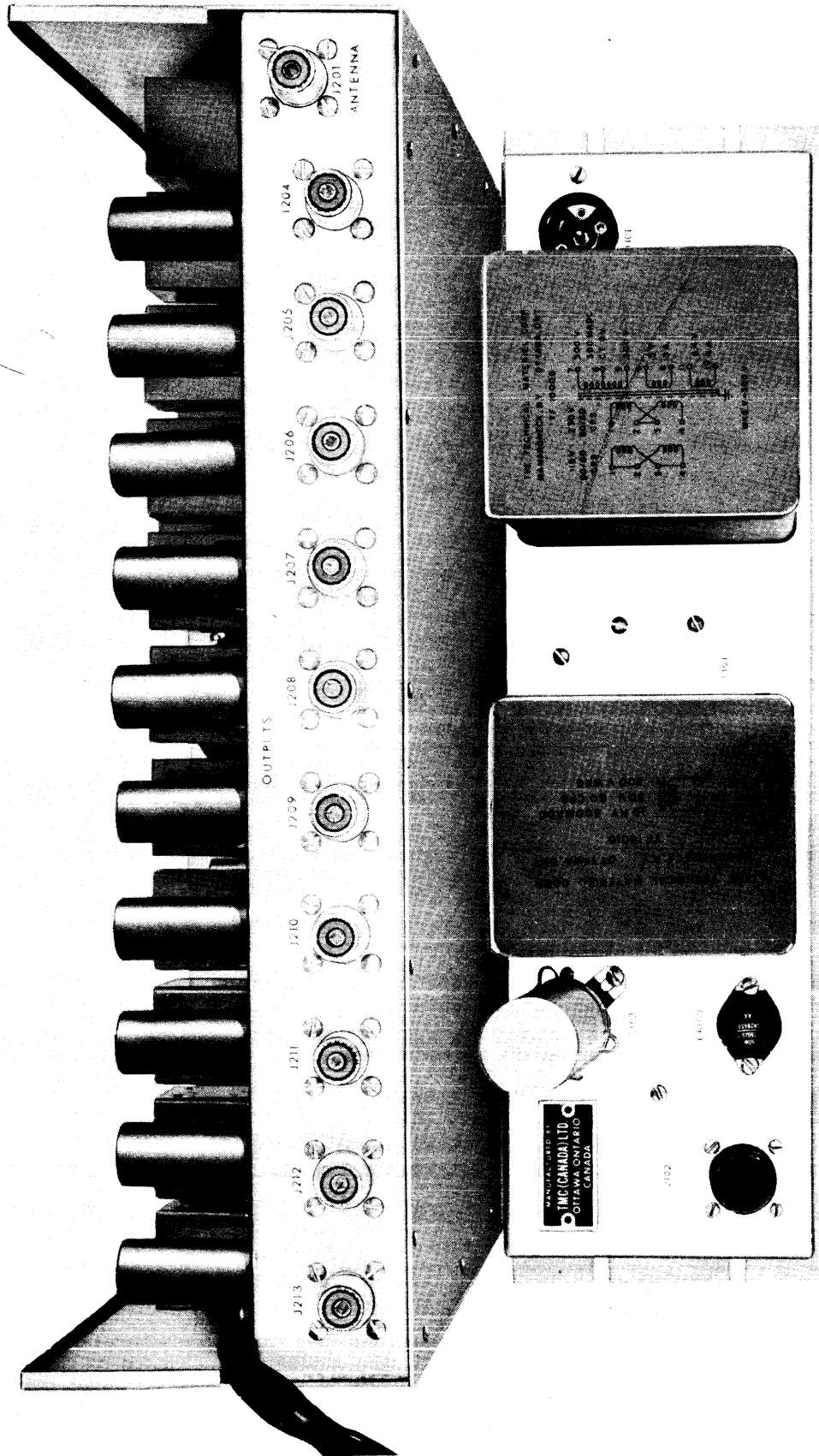

Figure 1-1b. Antenna Multicoupler LMC-10, Rear View

XCCIA-2

SECTION 1

GENERAL DESCRIPTION

1-1. PURPOSE AND BASIC PRINCIPLES.

Technical Materiel Corporation's Antenna Multi-coupler, LMC-10, is a broadband antenna-to-receiver coupling device. It consists of a broadband distributive amplifier, Model DA-101, and a solid state power supply, Model PS-7. It is normally used where it is desirable to employ a common antenna for several communications receivers.

The LMC-10 provides for ten receivers to be independently operated over a band of 100-kc to 2-mc from a non-resonant type antenna. Output impedances are 70-ohm unbalanced. LMC-10-70/U, consisting of DA-101-70/U and PS-7 has an input impedance of 70-ohms, unbalanced.

When the LMC-10 is used in a receiving system, it results in a general improvement in the noise factor and a 4-db improvement in overall gain. This gain is retained when driving one through ten receivers, if each receiver presents a true 70-ohm load. Spurious response generated in the multicoupler is kept to a minimum and the design of the LMC-10 results in a considerable reduction in the amplitude of signals re-radiated from receiver to receiver or receiver to the common antenna system. The LMC-10 has protection features against overloading by high-intensity RF signals. Operating frequency range is extended above 2-mc by operating a front panel switch.

If operation of more than 10 receivers from a common antenna is desired, LMC-10's may be cascaded. The output receptacles of the first LMC-10 are connected to the input receptacles of up to 10 other LMC-10's, which can provide outputs for as many as 100 receivers. Cascading LMC-10's in this manner does not seriously impair their performance.

1-2. DESCRIPTION OF UNIT.

The LMC-10 is shown in figure 1-1. It requires a total of 10-1/2 inches of height and 12 inches of depth in a standard 19-inch relay rack. The amplifier and the power supply are supported by their 3/16-inch thick front panels.

Controls and switches for the operation of the LMC-10 are located on the front panels. All vacuum tubes are readily accessible from the rear of the

LMC-10. The equipment is manufactured in accordance with JAN/MIL specifications.

a. Distributive Amplifier. The input requires 5-1/4 inches of height and 12 inches of depth in a standard 19-inch relay rack.

Front panel OUTPUTS/FILTER selector switch provides a bypass of the low pass filter in order to extend the operating frequency range above 2-mc. OUTPUTS 1 to 10 of this switch, together with the LOADED/UNLOADED meter and CAL switch provide a dynamic testing facility for each branch of the output while the equipment is in operation. CAL ADJUST potentiometer, on the front panel, is used for calibration of the LOADED/UNLOADED meter. All coaxial receptacles carrying RF signals to or from the amplifier are available at the rear of its chassis.

b. Power Supply. The unit requires 5-1/4 inches of height and 8-1/2 inches of depth in a standard 19-inch relay rack.

The power supply can operate from either 115V or 230V, 50/60 cps, single-phase main power. The only front panel control is the power ON/OFF switch. The main power fuse and a spare are located on the front panel. Power in and out receptacles are available at the rear of its chassis.

c. Equipment Supplied. Loose items shipped with the LMC-10 are as follows:

TMC PART NO	ITEM	QTY
CA-10125	AC Power Cord Assembly	1
CA-10133	Cable Assembly Amplifier to power supply interconnection	1
PL-259	Coaxial Plugs	11

1-3. REFERENCE DATA.

The crated dimensions of the LMC-10 are 17 by 22-1/4 by 23-1/4 inches. It weighs 122 pounds gross, packed for shipment. Tables 1-1 through 1-4 contain additional reference data pertinent to the LMC-10. Figures 1-2 through 1-4 illustrate performance characteristics.

TABLE 1-1. ELECTRICAL CHARACTERISTICS, AMPLIFIER

Connections:	
Antenna Input	Coaxial Receptacle, Type BNC.
Power Input	Receptacle, MS 3102A-16S-1P.
RF Outputs	Coaxial Receptacles (10), Type BNC.
Frequency response:	
Filter in	100-kc to 1.8-mc, flat within ± 2 -db. Insertion loss at 2-mc less than 4-db. Attenuation 50-db down at frequencies above 2.5-mc.
Filter out	100-kc to 2-mc, flat within ± 2 -db.
Gain:	100-kc to 2-mc, 4-db nominal.
Harmonic distortion:	Less than 1%.
Input impedance characteristic:	VSWR less than 1.8 to 1, referred to nominal impedance (see figure 1-4).
Insertion gain characteristics:	See figure 1-2.
Intermodulation:	Equivalent antenna voltage of intermodulated signal at least 50-db down with respect to the level of either of two equal amplitude signals whose equivalent antenna voltages to produce the intermodulated signal are 250K uv for a 70-ohm antenna. (See figure 1-3.)
Isolation:	
Output-to-input	Better than 60-db.
Output-to-output	45-db or better at 2-mc, increasing 3-db/octave to 60-db at 100-kc.
Noise factor:	
100-kc to 1.5-mc	Better than 7-db.
1.5-mc to 2-mc	
Filter in	Better than 8-db.
Filter out	Better than 7-db.
Nominal input impedance:	70-ohm, unbalanced. (Other impedances available on special order.)

TABLE 1-1. ELECTRICAL CHARACTERISTICS, AMPLIFIER (Cont.)

Output impedance characteristic:	Yields stated frequency response and gain when loaded with 70-ohms.
Uniformity of output signals:	Minimum signal voltage from any output receptacle not less than 75% of the signal voltage from any other output receptacle, when using electron tubes having at least 80% of their rated mutual conductance.

TABLE 1-2. ELECTRICAL CHARACTERISTICS, POWER SUPPLY

Input power:	115/230V, single-phase, 50/60 cps
Output voltages:	+300V DC (unregulated) +150V DC, nominal (regulated) 6.3V AC 5.0V AC
Power consumption:	120 watts

TABLE 1-3. VACUUM TUBE AND DIODE COMPLEMENT, AMPLIFIER

QTY	TYPE	FUNCTION	REFERENCE DESIGNATION
11	1N55A	RF Rectifier	CR201 thru CR210, CR212
2	5842/417A	Preamplifier	V201, V202
20	6C4	Cathode Follower	V203 thru V222
1	6922/6DJ8	1-mc Oscillator	V223

TABLE 1-4. DIODE COMPLEMENT, POWER SUPPLY

QTY	TYPE	FUNCTION	REFERENCE DESIGNATION
8	1N1084	Rectifier	CR101 thru CR108
1	1N2843B	Voltage Regulator	CR109

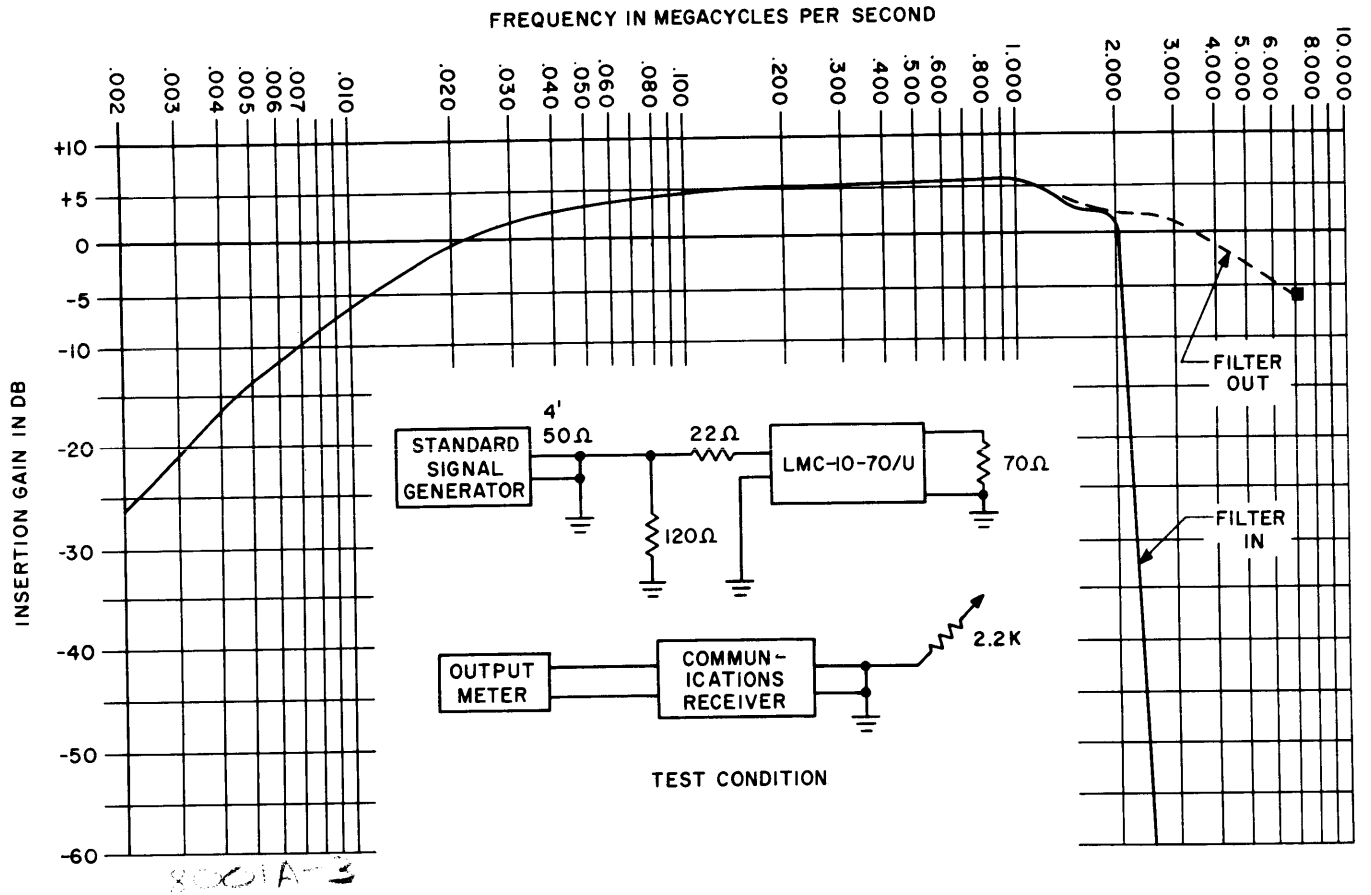

Figure 1-2. Typical Insertion Gain Characteristics, LMC-10-70/U

HIGH LEVEL SPURIOUS RESPONSE OF A SYSTEM EMPLOYING THE LMC-10-70/U

$$\text{SPURIOUS RESPONSE DB} = 20 \log_{10} \frac{E_1 \text{ OR } E_2}{E_3}$$

$\frac{E_1 \text{ OR } E_2}{E_3} = \frac{\text{AMPLITUDE OF } f_1 \text{ OR } f_2 \text{ AT THE ANTENNA JACK OF THE LMC-10-70/U}}{\text{AN EQUIVALENT VOLTAGE OF FREQUENCIES } (f_1, f_2) \text{ AT THE ANTENNA JACK OF THE LMC-10-70/U THAT WILL PRODUCE THE SAME OUTPUT AS WHEN } E_1 \text{ AND } E_2 \text{ ARE SIMULTANEOUSLY APPLIED TO THE INPUT}}$

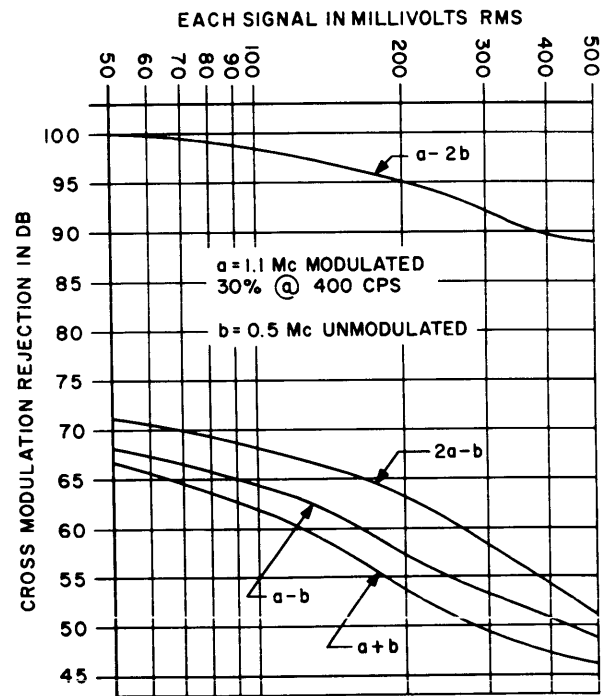
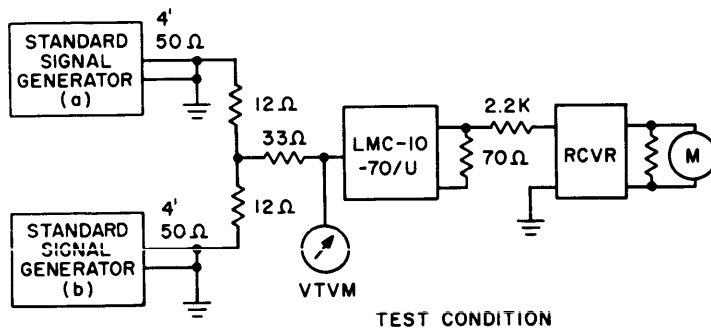

Figure 1-3. Typical Cross-Modulation Characteristics, LMC-10-70/U

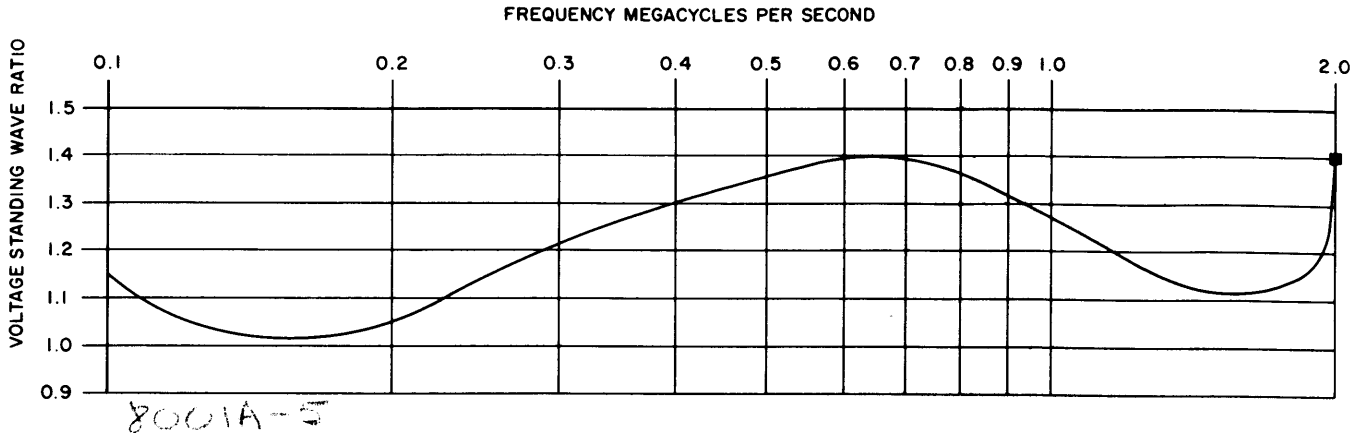

Figure 1-4. Typical Input Impedance Characteristics, LMC-10-70/U (Filter In)

MS 106

SECTION 2 INSTALLATION

2-1. INITIAL INSPECTION.

Each LMC-10 has been calibrated and tested at the factory before shipment. Upon arrival at the operating site, inspect the packing case and its contents immediately for possible damage. Unpack the equipment carefully. Inspect all packing material for parts which may have been shipped as "loose items" (See paragraph 1-2c for list). Although the carrier is liable for any damage to the equipment, Technical Materiel Corporation will assist in describing and providing for repair or replacement of damaged items.

The equipment is shipped with all tubes installed. Check that all tubes are properly seated in their sockets.

2-2. 115- VS. 230-VOLT POWER SUPPLY CONNECTIONS.

The power supply is designed for 115- or 230-volt, 50- or 60-cps, single-phase power; it is factory-wired for 115 volts. If 230-volt operation is required, minor wiring changes at transformer T101 are necessary. These are shown in figure 2-1.

NOTE

For 230-volt operation, fuse F101 should be changed to a slow blow fuse rated at 0.6 ampere.

2-3. INSTALLATION PROCEDURES.

a. Install the LMC-10 in a standard 19-inch relay rack or other housing as desired. The equipment may be mounted by its panels, and requires no additional support. Figure 2-2 is an outline dimensional drawing of the LMC-10.

b. Attach one of the male type BNC coaxial plugs (TMC Part No. PL-259), furnished with the LMC-10, to the antenna cable. Insert this plug into ANTENNA jack J201 at the rear of the amplifier. Attach the remaining male type BNC coaxial plugs to the 70-ohm single conductor coaxial cables which are to be connected to the antenna input terminals of the receivers. If the receiver inputs are other than 70-ohms, it is desirable to use impedance matching transformers between the cables and the receivers. Insert the plugs into the OUTPUT jacks J204 through J213 at the rear of the amplifier. Corresponding OUTPUT markings on the front panel OUTPUTS/FILTER selector switch are 1 through 10, respectively. When attaching coaxial plugs to coaxial cable, solder both the inner and outer conductors to ensure trouble-free service.

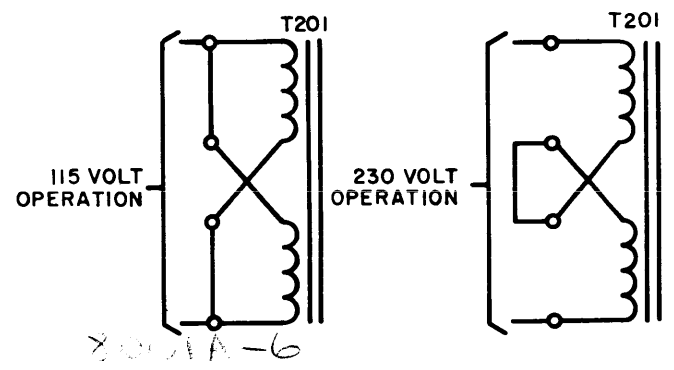

Figure 2-1. Installation Diagram Showing 115- vs 230-Volt Power Supply Connections

When less than 10 receivers are used with the LMC-10, the unused output jacks of the amplifier may be left open circuited without affecting performance of the equipment.

c. Cut the interconnection cable (TMC Part No. CA-10133), furnished with the LMC-10, to the desired length. Attach the straight 7-pin plug, MS3106B-16S-1P, to the cable and connect to receptacle J102 at the rear of the power supply. Attach the 90° 7-pin plug, MS3108B-16S-1S, to receptacle J214 located on the upper surface of the amplifier chassis. Secure the cable with the nylon cable clamp located near vacuum tube V222.

d. Determine main power supply voltage and check power supply for correct transformer connections (refer to paragraph 2-2). With power supply power ON-OFF switch in OFF position, connect LMC-10 to main power by installing power cord assembly (TMC Part No. CA-10125), furnished with LMC-10. Connect male plug to main power source and connect female plug to receptacle J101 at the rear of the power supply chassis. Lock plug at receptacle J101 by rotating it in a clockwise direction.

2-4. INITIAL ADJUSTMENT—DYNAMIC CHECKING SECTION.

a. Place power supply power ON-OFF switch in ON position. Allow 3 hours warmup time.

b. Disconnect load from output number 1 (J204).

c. Set the OUTPUTS/FILTER switch to OUTPUT 1. Adjust CAL ADJUST potentiometer R242 through the front panel until LOADED/UNLOADED meter indicates in the center of the green sector.

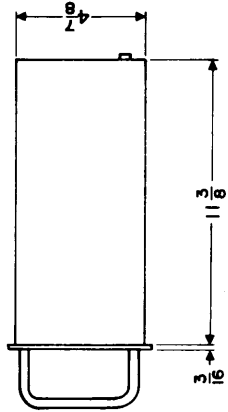
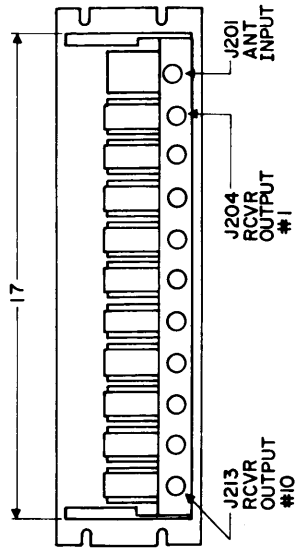

DA-101-70/U DISTRIBUTIVE AMPLIFIER

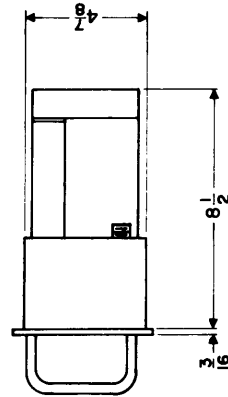
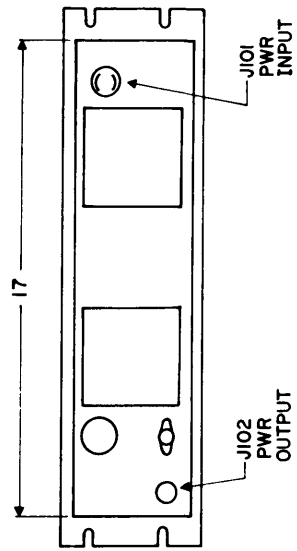

PS-7 POWER SUPPLY

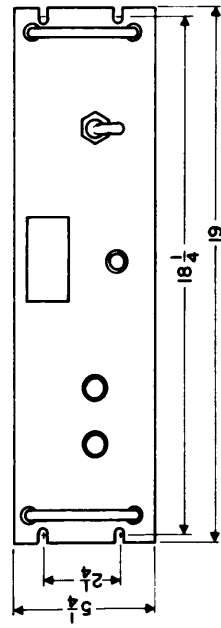
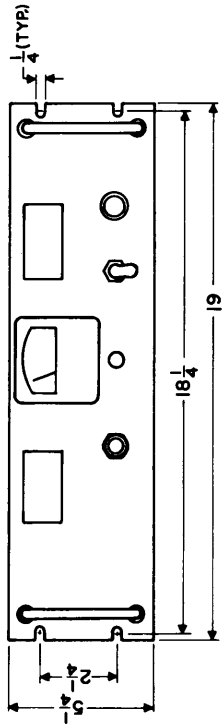

Figure 2-2. Outline Dimensional Drawing, LMC-10

d. Press CAL switch and adjust trimmer capacitor C267 from top of the chassis until meter indication coincides with CAL mark on dial. Release CAL switch.

e. Select OUTPUTS 1 through 10 with OUTPUTS/FILTER switch. Determine that the output indication on the LOADED/UNLOADED meter falls in the appropriate range for loaded and unloaded outputs.

NOTE

The loaded condition indication on the LOADED/UNLOADED meter is calibrated for a 70-ohm load. If the meter does not indicate in the loaded sector of the dial when calibrating in the loaded condition, determine that the indications is in the unloaded sector of the dial when the particular output is unloaded. The receiver being checked may not present a true 70-ohm load when tuned. Some receivers have low input impedance characteristics when not tuned to resonance. With such receivers it is necessary to tune the receiver to the calibration oscillator frequency (1.0-mc) to make this test.

When rechecking the LMC-10 after initial adjustment of the dynamic checking section, proceed as follows:

Set the OUTPUTS/FILTER switch to OUTPUT 1. Press CAL switch and adjust CAL ADJUST potentiometer R242 until indication coincides with CAL mark on dial. Release CAL switch. In the unloaded condition all output indications should fall in the green sector of the meter dial.

2-5. SPECIAL CONDITIONS.

a. Use of More Than 10 Receivers. LMC-10's may be cascaded. The outputs of the first LMC-10 are connected to the input jacks of up to 10 LMC-10's. These equipments can provide outputs for as many as 100 receivers. Cascading LMC-10's in this manner does not seriously impair their performance.

b. Signals of Over 3 Volts. A switching provision on the amplifier (FILTER IN position) makes it possible to attenuate signals of 2-mc and over to eliminate intermodulation in the receiving system caused by reception of the broadcast band. The LMC-10 has been designed to minimize any type of intermodulation. If intermodulation does occur, additional filters may be inserted in the antenna transmission line.

SECTION 3 OPERATOR'S SECTION

3-1. OPERATOR'S INSTRUCTIONS.

Table 3-1 provides equivalent control designations for the operating controls shown in figure 3-1 and the component designations of figures 8-1 and 8-2.

When the LMC-10 has been installed as discussed in Section 2, and the LOADED/UNLOADED meter calibrated as discussed in paragraph 2-4, the LMC-10 is operated by placing power supply power switch in the ON position. Leave OUTPUTS/FILTER switch in the FILTER IN during ordinary operation. Use the FILTER OUT position only when the operator wishes to tune his receiver above 2-mc.

A dynamic check of the LMC-10 can be made during operation. Controls for this purpose are the OUTPUTS/FILTER switch and the LOADED/UNLOADED meter. Check any or all branches of the LMC-10 by setting OUTPUTS/FILTER switch to the appropriate branch number and observing LOADED/UNLOADED meter. The meter has black and green sectors on its dial to indicate proper levels for loaded and unloaded amplifier output jacks J204 through J213. Positions 1 to 10 on OUTPUTS/FILTER switch correspond with jacks J204 to J213, respectively. In positions 1 through 10, the antenna input is disconnected from the LMC-10. A 1-mc test signal generated in the amplifier is substituted for the antenna signal.

NOTE

Some receivers have input impedance characteristics which are very low when not tuned to resonance. Such receivers must be tuned to 1-mc to check the LMC-10 for proper functioning.

CAL switch and CAL ADJUST potentiometer on the front panel of the amplifier are for calibrating the meter to the receivers. Refer to paragraph 2-4 for procedure.

3-2. OPERATOR'S MAINTENANCE.

The operator should note general condition of panel switches, observe whether the panel indicator lamps light, and check the tubes. The locations of all tubes in the amplifier are indicated by the tube location diagram of figure 5-1. There are no tubes in the power supply. Use the substitution method when checking tubes.

Power is supplied for operation of the amplifier by throwing the power switch on the power supply to the ON position. The "on" condition is indicated by the illuminated pilot lights on the front panels of the amplifier and power supply. Failure of the pilot lights to be illuminated may be due to failure of AC main power, defective switches, or burned-out lamps. A blown main power fuse is indicated by illumination of the fuse holder on the front panel of the power supply.

CAUTION

Do not replace a fuse with one of higher rating. If a fuse burns out immediately after replacement, do not replace it a second time until the trouble has been located and corrected.

TABLE 3-1. EQUIPMENT CONTROL DESIGNATIONS

SERIAL DESIGNATION (FIGURE 3-1)	PANEL DESIGNATION (FIGURE 3-1)	COMPONENT REFERENCE DESIGNATION ON OVERALL SCHEMATICS (FIGURES 8-1 AND 8-2)
1	OUTPUTS-FILTER knob control (OUT 1-10 IN)	Rotary switch S201A, B, C, D
2	Meter	Meter M201
3	CAL ADJUST adjustment	Potentiometer R242
4	CAL toggle switch	Toggle switch S202
5	POWER indicator	Indicator I201
6	ON-OFF toggle switch	Toggle switch S101
7	POWER indicator	Indicator I101
8	1.25A/115V .625A/230V fuseholder	Fuse holder XF101

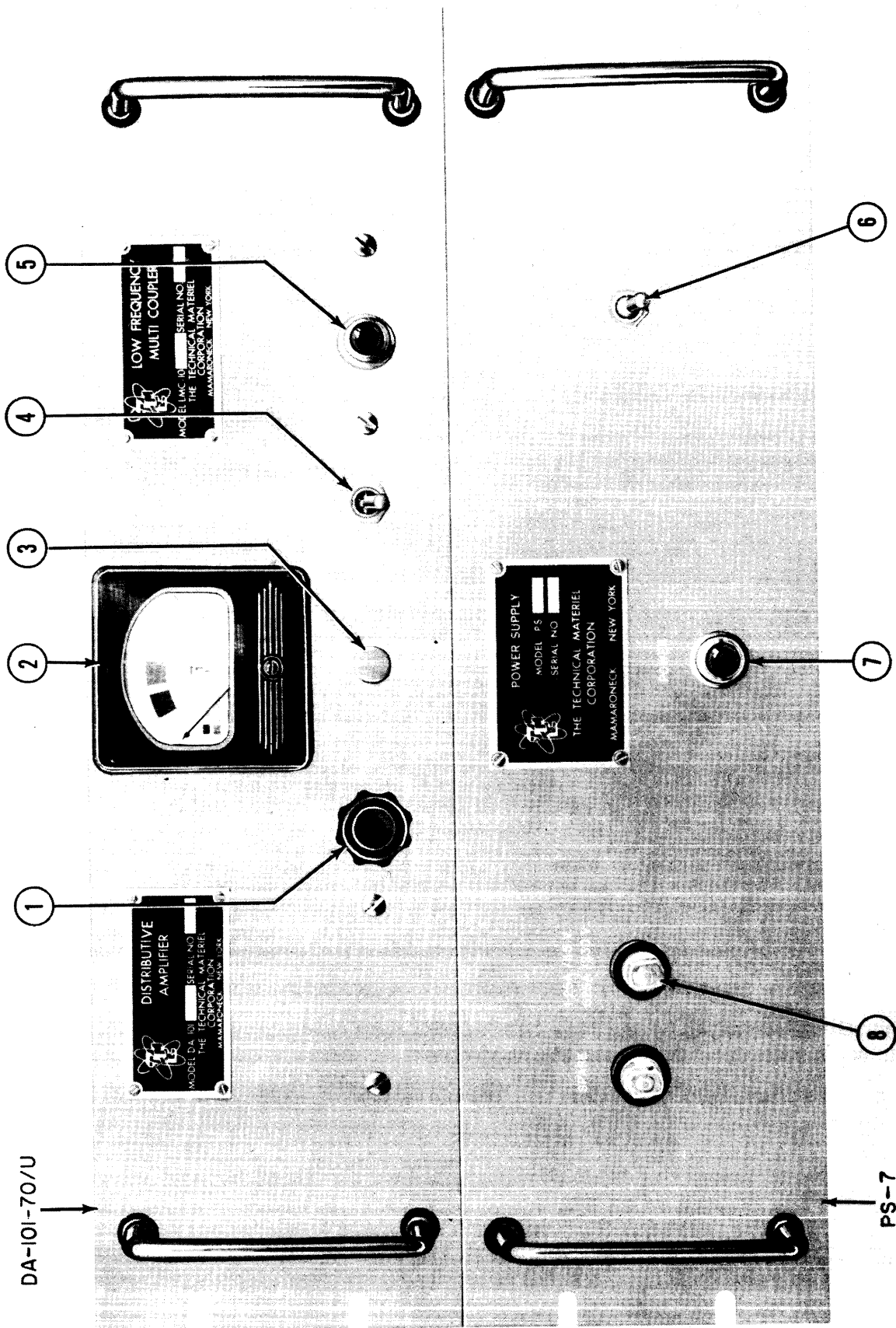

Figure 3-1. Panel View of LMC-10 Showing Operating Controls

SECTION 4

PRINCIPLES OF OPERATION

4-1. GENERAL.

The LMC-10 is a broadband amplifier interposed between an antenna and the antenna terminals of conventional communications receivers. Impedances into and out of the amplifier are flat over the specified operating range to insure high performance when operated in a receiving system. The amplifier, as shown in figure 4-1, has four major sections. The sections are described in detail in paragraphs 4-2 through 4-5, below. Paragraph 4-6, below, describes the power supply.

4-2. INPUT AND PREAMPLIFIER SECTION.

The antenna signal is routed to the preamplifier via a low-pass broadcast band filter whose cut-off frequency is 2-mc. As shown in figure 4-2, positions 1 and 2 of wafers A and B of selector switch S201 allow a switching in or out of the 2-mc cut-off filter Z201, as required. Switching in the filter attenuates the broadcast band; switching out the filter extends the high-frequency range of the LMC-10. The preamplifier amplifies the signal and is a low noise, push-pull type. Positions 3 through 12 of wafer B of selector switch S201 serve a purpose for the dynamic checking section, as described in paragraph 4-4, below. Filter Z201 attenuates all frequencies of 2-mc and higher, and has a 70-ohm unbalanced input and output.

The preamplifier, as shown in figure 4-3, is a push-pull, grounded grid type, having a 70-ohm input and output impedance, and a nominal gain of 11-db. The output from the signal input section is coupled to the preamplifier by impedance matching transformer T201. Potentiometer R201 balances the preamplifier circuitry for minimum cross-modulation effects resulting from more than one signal.

4-3. OUTPUT DISTRIBUTION SECTION.

The preamplifier output is coupled to the output distribution section by an impedance matching drive transformer T203. Delay lines DL201 and DL202 feed the ten push-pull cathode follower stages, which serve to isolate the LMC-10 from the effects of faulty receivers and varying loads. Cathode follower outputs are impedance matched to the amplifier outputs through transformers T204 through T213.

As shown in figure 4-4, two disconnect points are provided at the preamplifier output and impedance matching drive transformer T203 input, in the form of J202, P201, J203, and P202. In an emergency, due to component failure in the preamplifier during operation of the LMC-10, cable, TMC Part No. CA-10114, may be removed and the antenna lead connected to J203, bypassing the preamplifier.

Impedance matching drive transformer T203 drives the lumped constant delaylines DL201 and DL202, and matches the 70-ohm impedance of the preamplifier output to the 510-ohm characteristic impedance of the delaylines. The delay lines feed the ten output stages in parallel and are terminated by precision non-reactive resistors R233 and R234. Trimmer capacitors C202, C203, C208, C209, etc. are used to adjust the delay lines to 510-ohms ± 10 .

In the typical output stage shown in figure 4-4, a push-pull cathode follower circuit is driven by two delay lines and is coupled to the J204 70-ohm output by impedance matching transformer T204, which has a 1000-ohm primary and a 70-ohm secondary.

4-4. DYNAMIC CHECKING SECTION.

Checking of the LMC-10 during operation is provided for by an internally generated test signal of 1-mc, which can be inserted at the preamplifier input and the resulting current level read on panel meter M201 for each amplifier output stage. The 1-mc signal generated by the 1-mc oscillator is routed through any one of the ten output branches by positions 3 through 12 of selector switch S201. The 1-mc is converted to a d-c current through a low-pass filter and registers on meter M201. In positions 3 through 12 of selector switch S201, the antenna input is disconnected to prevent re-radiation into the antenna or malfunctioning of the LMC-10 due to component failure in the dynamic checking section.

Switch S202 is used in calibrating meter M201. Holding down switch S202 in the CAL position reroutes the 1-mc test signal directly through the meter, via a low-pass filter, which converts it to d-c current. While the switch is down, a calibration adjustment may be made with potentiometer R242 and capacitor C267, to compensate for line voltage variations and environmental conditions.

As shown in figure 4-5, V223A, CR211, C263, R236, C264, and R237 comprise a modified Pierce oscillator driving cathode follower V223B. The 1-mc output of the cathode follower at pin 8 of V223B is inserted into the preamplifier input through normally closed switch S202 and wafer B of selector switch S201 when this switch is in positions 3 through 12. Figure 4-5 has heavy lines to show the test signal path with selector switch S201 in position 3 for checking output no. 1. The resulting 1-mc appearing at J204 (see figure 4-4) is picked up and routed through low-pass filter CR201 and C207 (see figure 4-5), to meter M201 via wafer C of selector switch S201. The meter registers the resulting d-c current and has sectors on its dial indicating the normal ranges for loaded and unloaded outputs.

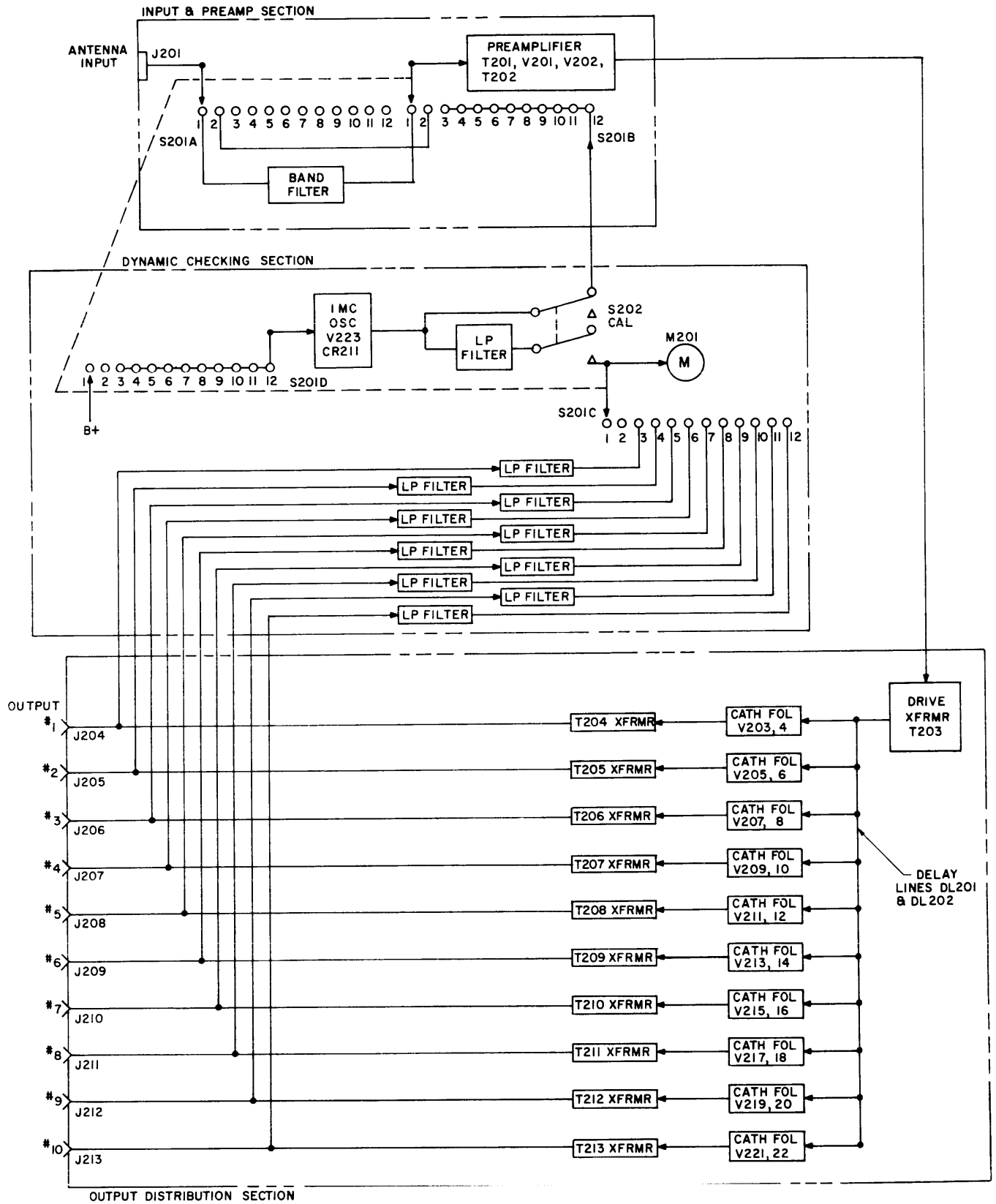

1001A-9

Figure 4-1. Block Diagram, Amplifier

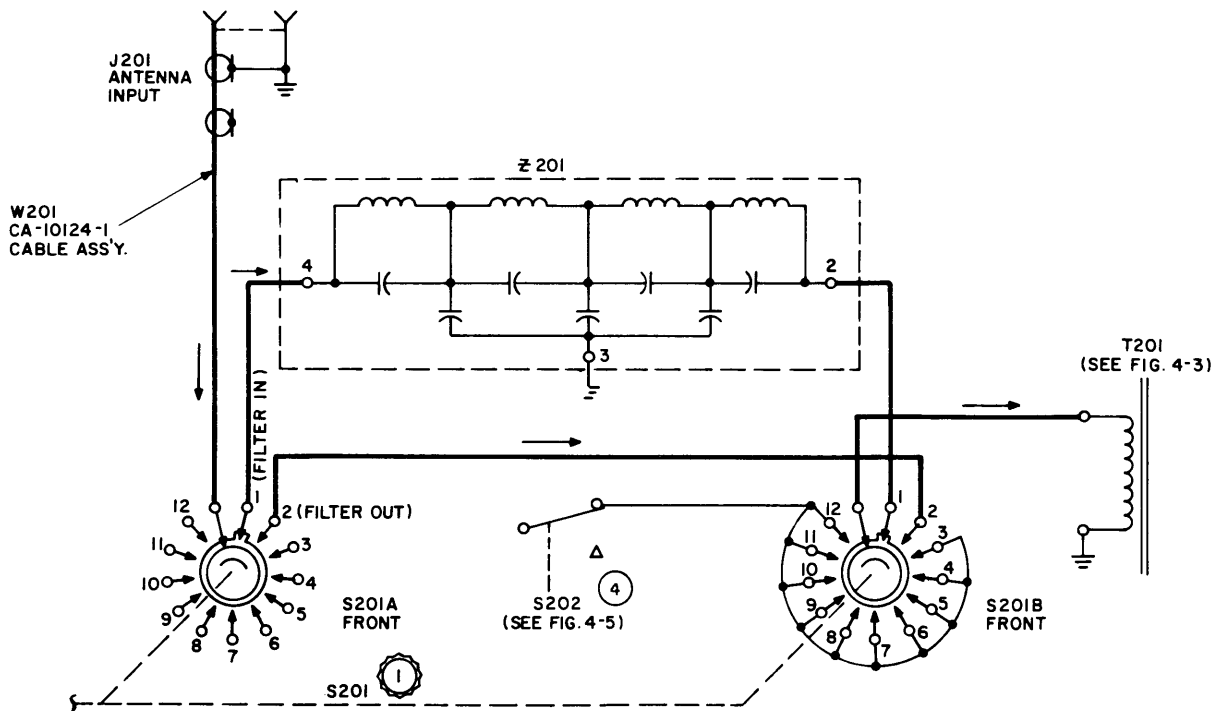

NOTE:
 1- SEE FIGURE 3-1 FOR LOCATION OF NUMBERED CONTROLS ON PANEL.

2001A-10

Figure 4-2. Schematic Diagram, Amplifier Signal Input Section

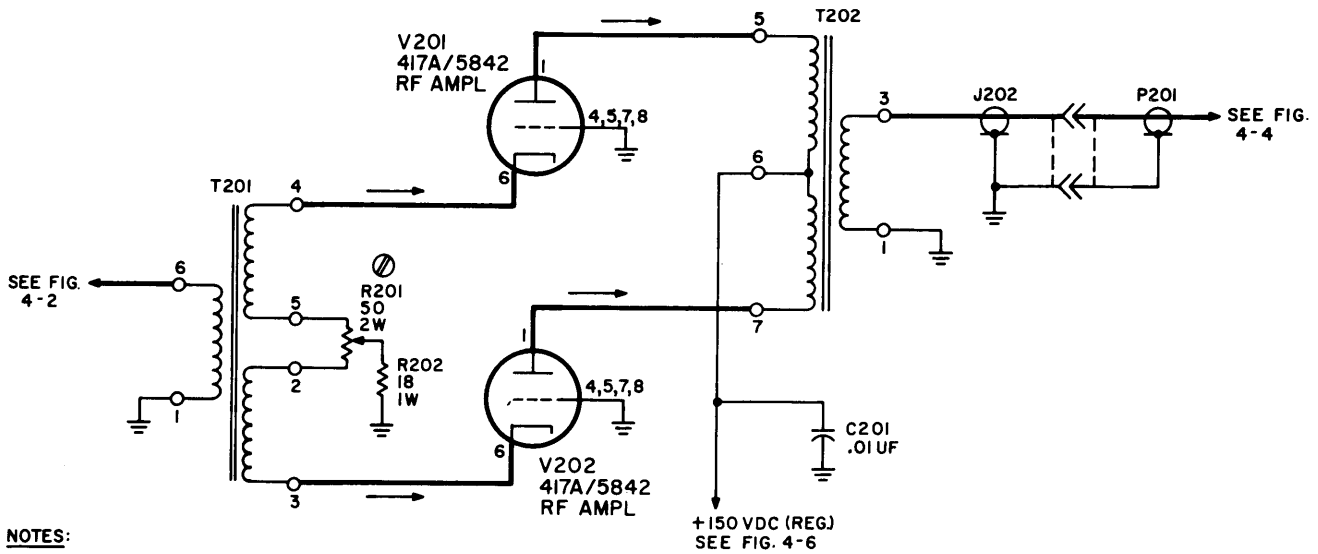

NOTES:
 1- Ⓛ INDICATES SCREWDRIVER CONTROL ON CHASSIS.

8001A-11

Figure 4-3. Schematic Diagram, Amplifier Preamplifier Section

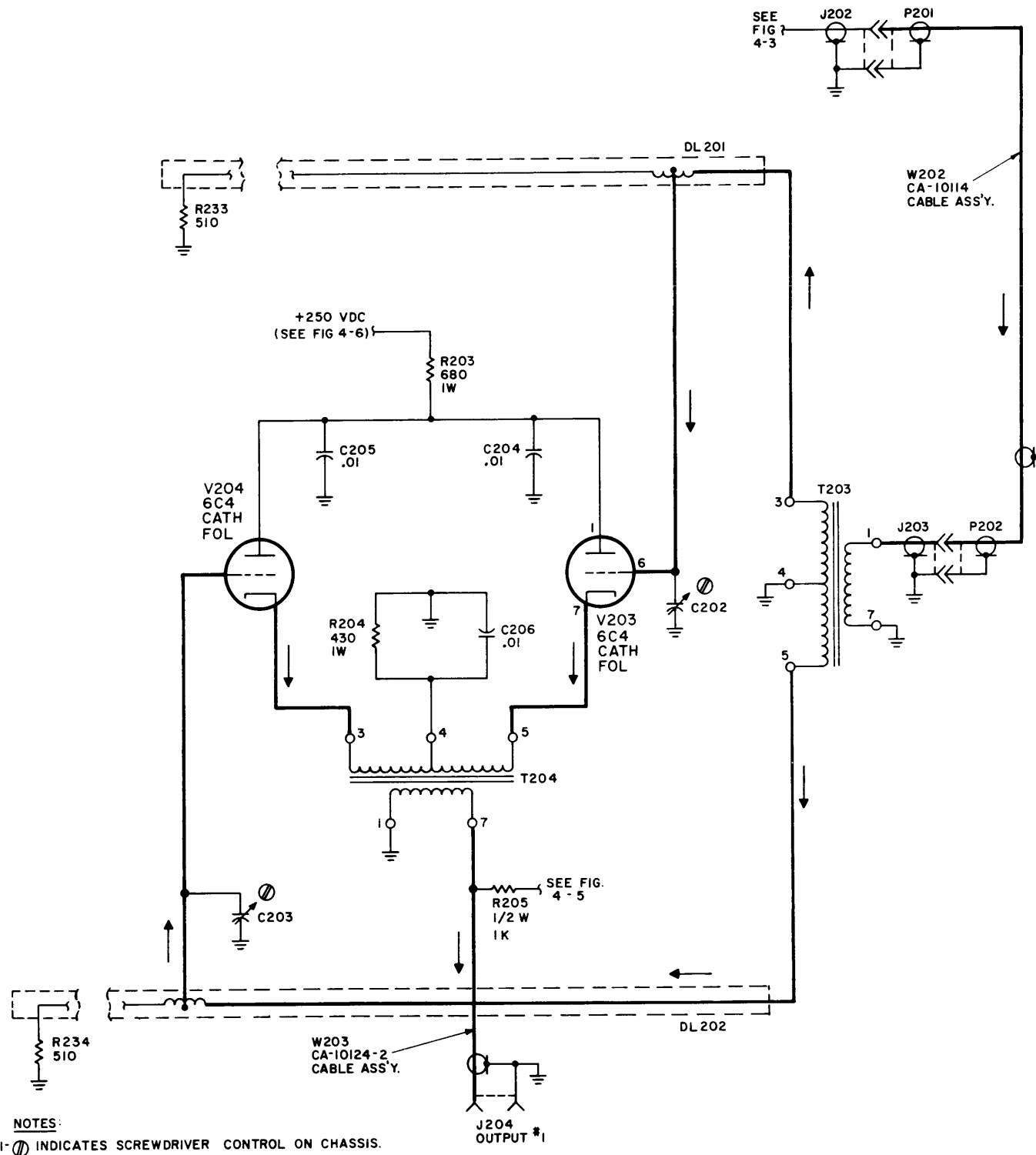

- NOTES:
- 1- Ⓢ INDICATES SCREWDRIVER CONTROL ON CHASSIS.
 - 2- UNLESS OTHERWISE NOTED ALL CAPACITOR VALUES ARE IN UF.

1001A-12

Figure 4-4. Schematic Diagram, Output Distribution Section Showing Typical Output Stage

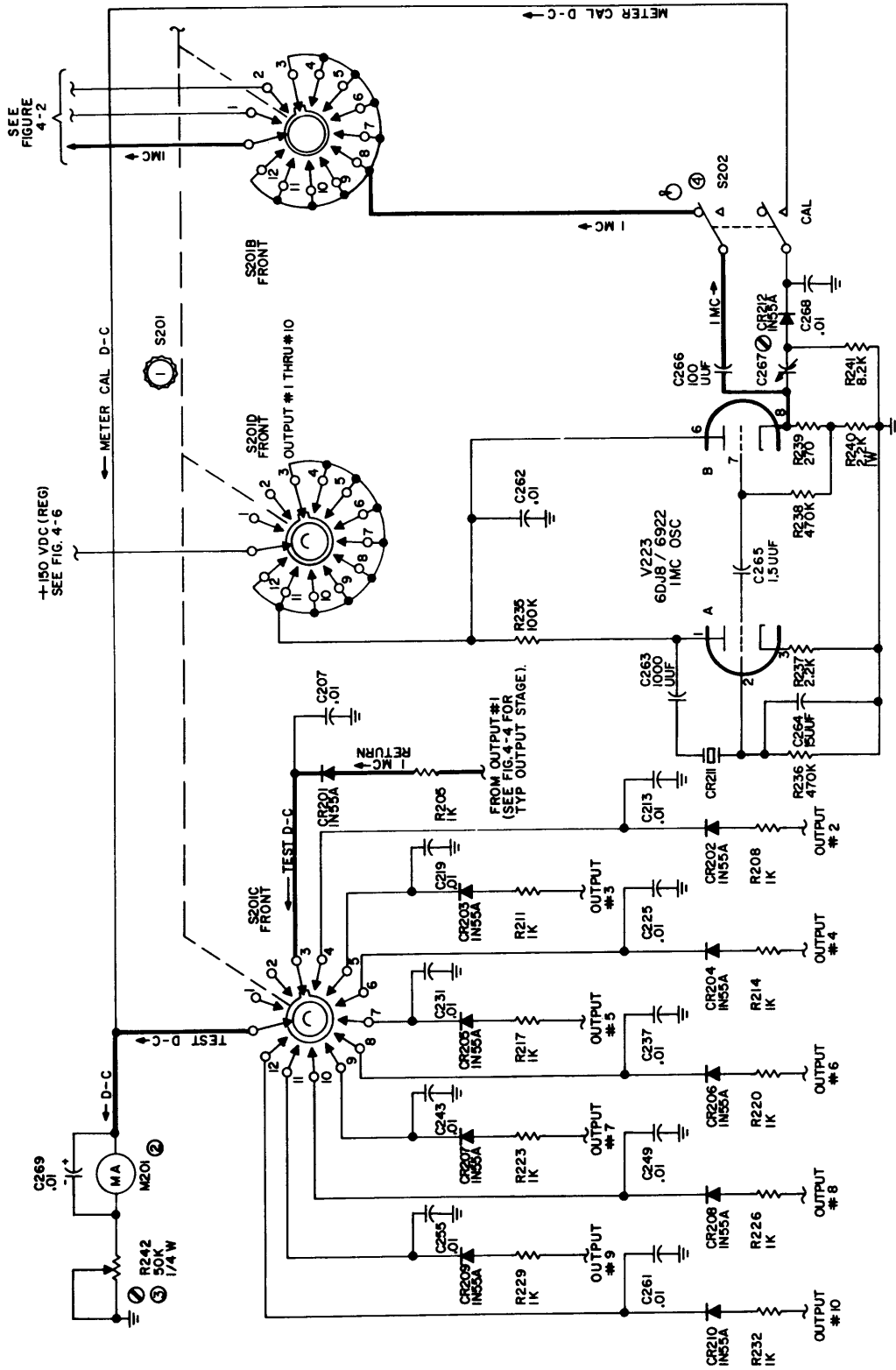

- NOTES
- 1- SEE FIGURE 3-1 FOR LOCATION OF NUMBERED CONTROLS ON PANEL.
 - 2- UNLESS OTHERWISE NOTED: ALL RESISTORS ARE 1/2 WATT ALL CAPACITOR VALUES ARE INUF.
 - 3- $\text{\textcircled{1}}$ INDICATES SCREWDRIIVER CONTROL ON CHASSIS
 - 4- S201 SWITCH SHOWN IN POSITION FOR CHECKING #1 OUTPUT.

FIGURE 4-5. SCHEMATIC DIAGRAM, DYNAMIC CHECKING SECTION, DA-301-7070-DISTRIBUTIVE-COMPLIANT

Figure 4-5. Schematic Diagram, Amplifier Dynamic Checking Section

8001A-13

4-5. POWER INPUT SECTION.

As shown in figure 4-6, power for the amplifier enters at J214 from the power supply. +250 VDC, unregulated, is used for plate supply to the ten cathode follower output stages. +150 VDC, regulated, is used for the plate supply to the preamplifier and 1-mc oscillator. 6.3 VAC is used for all tube filaments. L201, C274, L202, and C275 decouple any a-c hum produced in the V201 and V202 heater-type filaments. 5 VAC is used for the POWER indicating lamp I201.

4-6. POWER SUPPLY.

The power supply is a conventional solid-state circuit, designed for operation from either 115- or 230-volt line voltage.

The power supply employs a power transformer T101, and a full-wave bridge rectifier CR101 through CR108. CR109 is a zener diode that acts as a voltage regulator for +150 VDC. POWER lamp I101 indicates that the power supply is receiving line voltage.

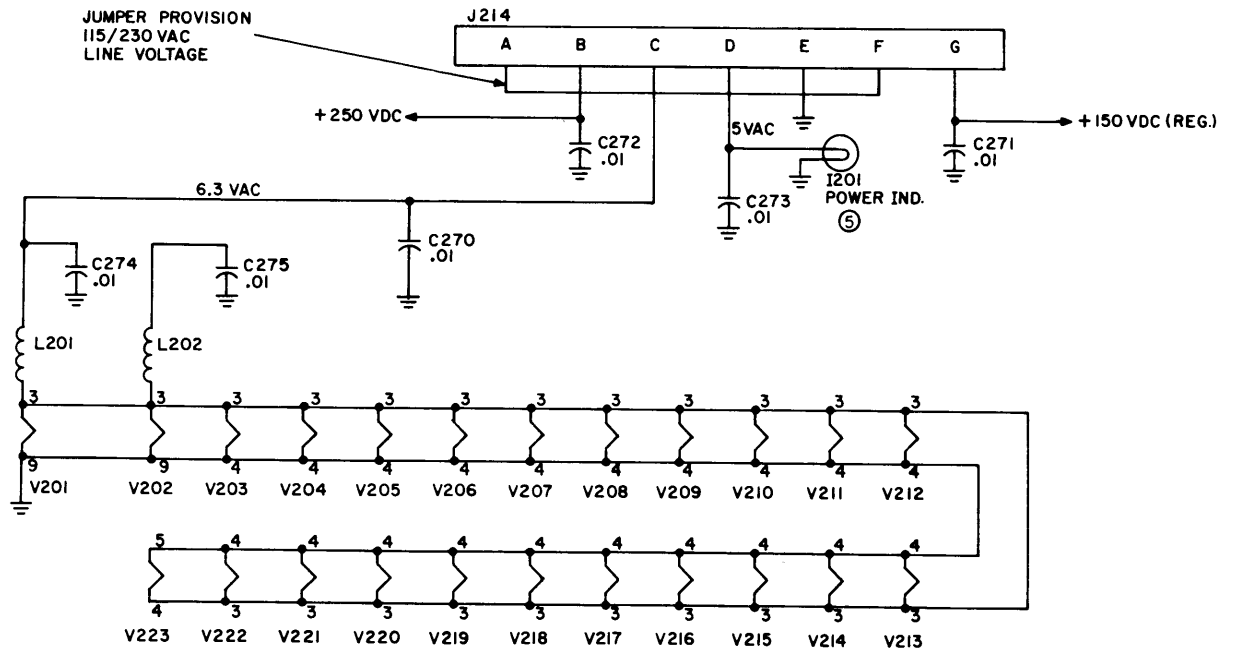

NOTES:

1- SEE FIG. 3-1 FOR LOCATION OF NUMBERED CONTROLS ON PANEL.

2001A-14

Figure 4-6. Schematic Diagram, Amplifier Power Input Section

SECTION 5 TROUBLE-SHOOTING

5-1. INTRODUCTION.

This section explains how to locate and diagnose equipment troubles and maladjustments. The information necessary to remedy the troubles and maladjustments will be found in Section 6 of this manual under the heading "Maintenance".

The following aids to trouble-shooting are provided:

- a. General trouble-shooting procedure.
- b. Trouble-shooting based on operational procedure.
- c. Voltages and resistances, amplifier.
- d. Voltages and resistances, power supply.
- e. Trouble-shooting based on circuit sectionalization.

5-2. GENERAL TROUBLE-SHOOTING PROCEDURE.

When a piece of equipment has been working satisfactorily and suddenly fails, the cause of failure may be apparent either because of circumstances occurring at the time of failure or because of symptoms analogous to past failures. In this case, it is unnecessary to follow a lengthy and orderly course of trouble-shooting in order to localize and isolate the faulty part. A second short cut in trouble-shooting is to ascertain that all tubes and fuses are in good condition; also that the equipment receives proper supply voltages. This may eliminate further investigation. A third short cut is to examine the equipment, section by section, for burned out elements, charring, corrosion, arcing, excessive heat, dirt, dampness, etc. Component defects may be internally or externally caused.

5-3. TROUBLE-SHOOTING BASED ON OPERATIONAL PROCEDURE.

The general purpose of this paragraph is to narrow the area of trouble to one or more sections of the equipment in order to minimize the labor of locating the source of trouble. The following information is based on specific troubles encountered during operation of the LMC-10.

a. Failure of one or more outputs. If low output is observed at one or more outputs when tested with OUTPUT/FILTER switch and LOADED/UNLOADED meter, it is most probably tube failure. Tubes in the defective stages should be checked.

b. Weak or noisy signals in all receivers. If weak or noisy signals occur in all receivers, make a rough check of the antenna system by connecting the antenna lead-in directly to the antenna terminals of a receiver. If the weakness or noise disappears, check the preamplifier of the LMC-10 for security of interconnecting cables and for noisy or low emission tubes.

c. Weak or noisy signal in one receiver. When only one receiver in the system gives faulty performance, check the receiver itself or the particular output tubes in the LMC-10 that supply signals to the particular receiver.

d. Complete loss of signals in all receivers. If the system fails (indicated by loss of signals in all receivers), the method discussed in subparagraph b, above, may be used to determine if the trouble is in the LMC-10. If this appears to be, determine that all tube filaments are heated. Then check the LMC-10 with its dynamic checking circuit. Low output at all output jacks indicates failure of the preamplifier or defective interconnecting cables. Emergency operation with a defective preamplifier can be accomplished by removing the plug from J201 and inserting it in J203, thus by-passing the preamplifier circuit.

5-4. VOLTAGES.

Tables 5-1 and 5-2 show voltages measured at tube pins. Figures 5-1, 5-2, and 5-3 locate component parts by reference designations.

5-5. TROUBLE-SHOOTING BASED ON CIRCUIT SECTIONALIZATION.

The following input vs. output check is for the purpose of narrowing the trouble source down to a particular section of the amplifier. This method is not intended to be entirely conclusive, but may be generally used to expedite trouble-shooting when the test equipment is available. The output figures given are nominal; any great deviation from the values will indicate an abnormality.

Test equipment required for this check is as follows:

Signal Generator	Measurement Corporation, Model 82 (or equivalent)
70-ohm non-inductive load	68-ohm \pm 1% non-inductive resistor may be used
Frequency Meter	
Voltmeter	Avo Model 8 (or equivalent)

TABLE 5-1. TUBE OPERATING VOLTAGES, AMPLIFIER

Tube	Pin 1	Pin 2	Pin 3	Pin 4	Pin 5	Pin 6	Pin 7	Pin 8	Pin 9
V201, V202	143		6.3*			1.65			
V203 thru V222	245		6.3*	0	245	0	8.0		
V223	34.5	0	1.0	6.3	0	135	3.25	23	0

- CONDITIONS: (1) Measurements made with AC power line voltage equal to 115V.
- (2) All DC voltages measured to ground with AVO meter, Model 8.
- (3) All AC voltages measured to ground with Hewlett-Packard, Model 410B.
- (4) Voltages for V223 measured with oscillator ON (with switch S201 in positions 1 or 2 through 10); all other voltages oscillator off (with switch S201 in FILTER IN position).
- (5) Voltages marked with an asterisk (*) are AC.

TABLE 5-2. OUTPUT VOLTAGES, POWER SUPPLY

Transformer T101- Terminal Number		Output Receptacle J102 - Pin Letter						
6	7	A	B	C	D	E	F	G
133	133	115x	248	6.3*	5.0	0	115x	140

- CONDITIONS: (1) Measurements made with AC power line voltage equal to 115V.
- (2) All DC voltages measured to ground with AVO meter, Model 8.
- (3) All AC voltages except pin A and pin F measured to ground with Hewlett-Packard, Model 410B.
- (4) Voltages marked with an asterisk (*) are AC.
- (5) Voltages marked with (x) are line voltage.

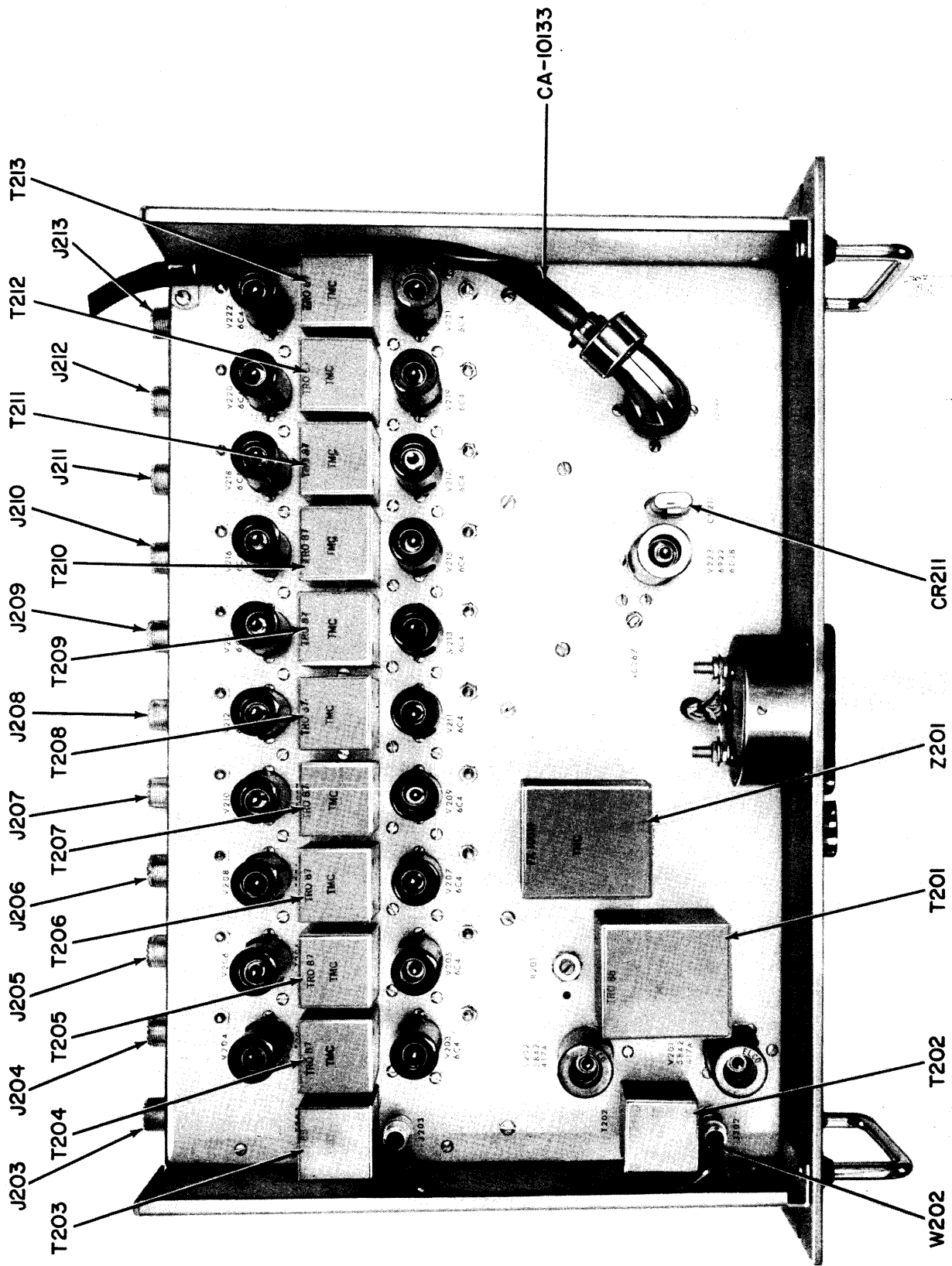
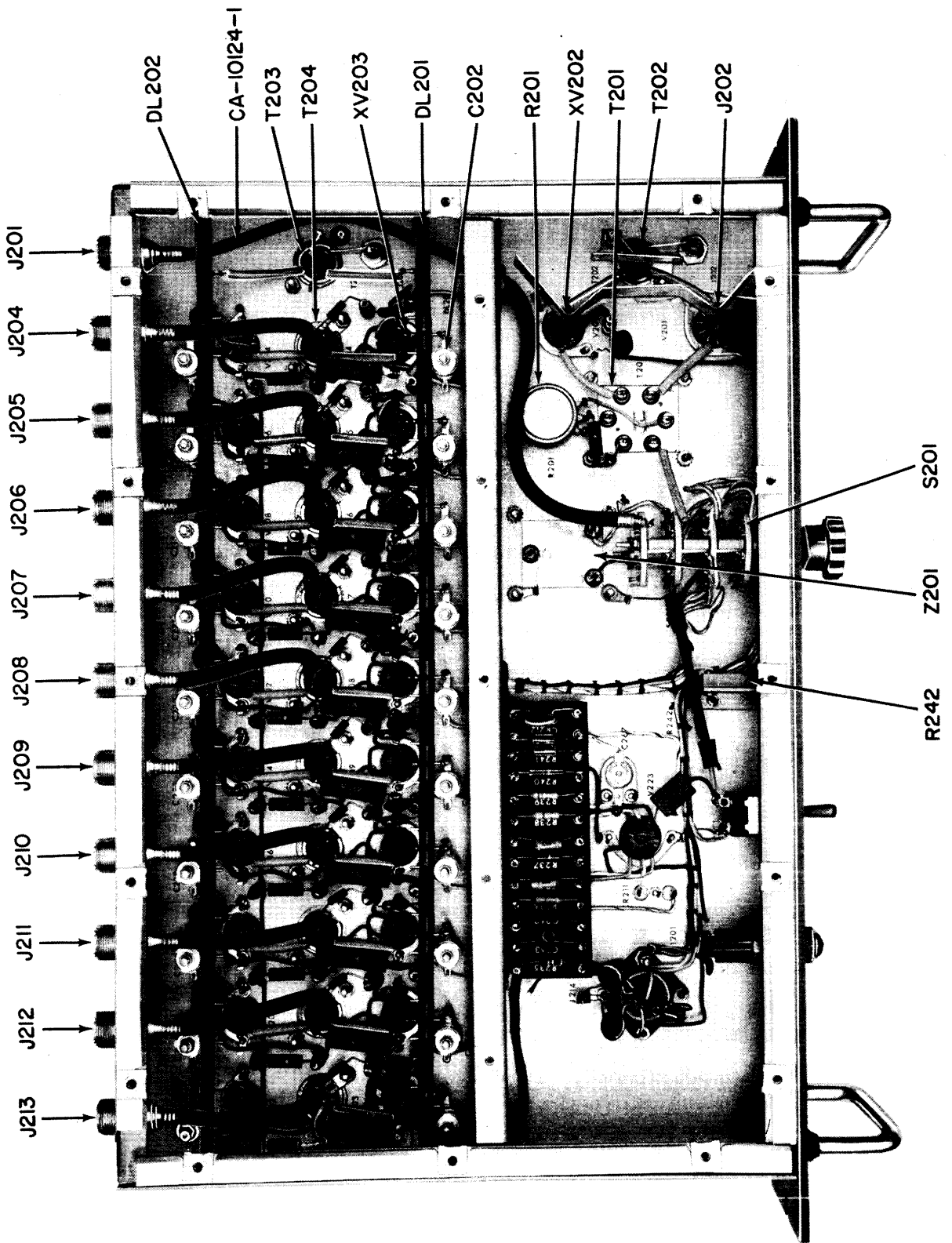

Figure 5-1. Location Diagram of Major Electronic Components, Amplifier, Top View



8001A-16

Figure 5-2. Location Diagram of Major Electronic Components DA-101-70/U, Bottom View

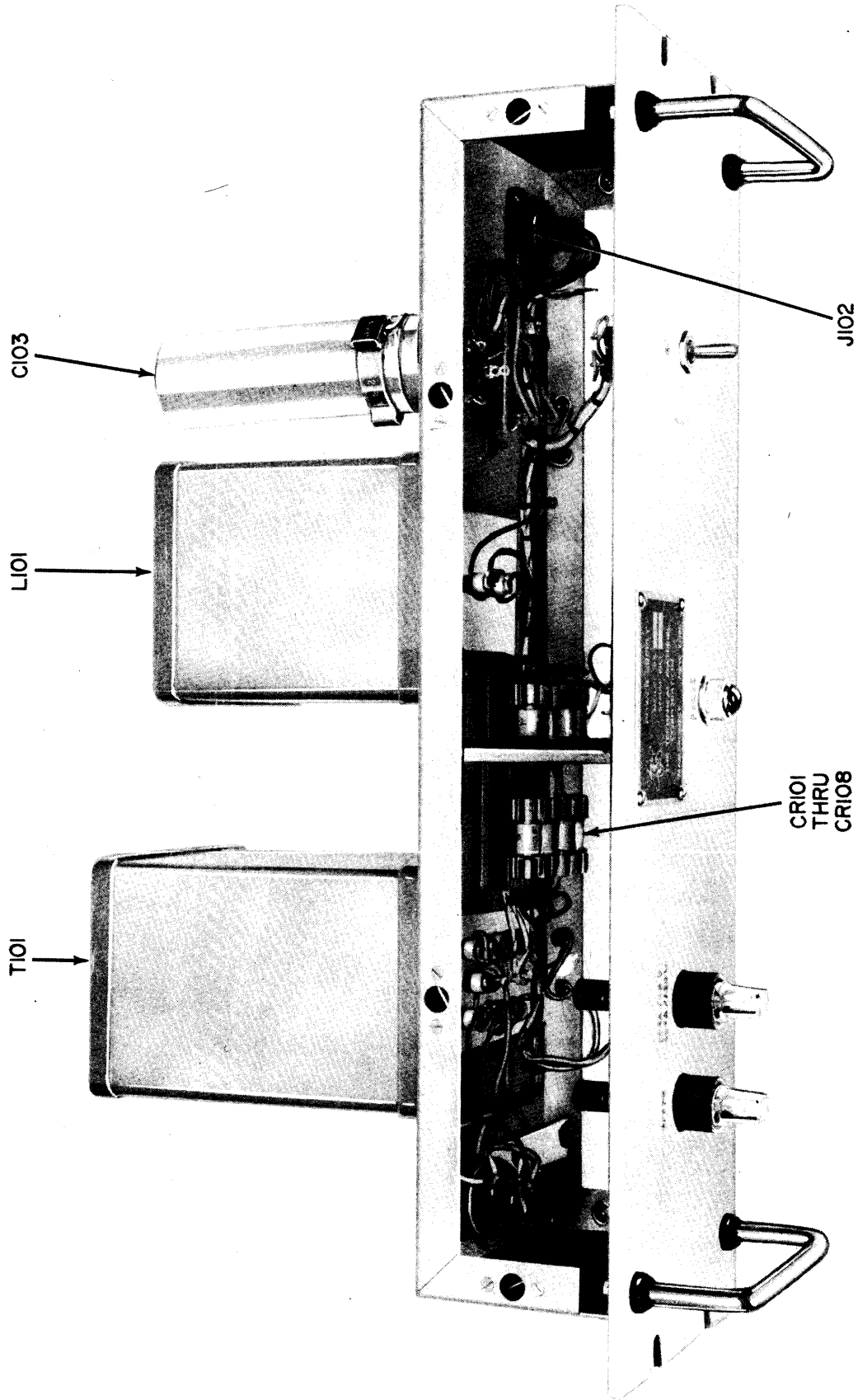

Figure 5-3. Location Diagram of Major Electronic Components PS-7, Top View

Connect the 70-ohm load across J204 and proceed with section-by-section check as follows:

a. Input and Preamplifier Section. Connect the signal generator to J201 antenna input and set for 100-kc at 200-mv. Set switch S201 FILTER IN/OUT to FILTER OUT. Attach VTVM to pin 3 of T202; reading should be 740-mv nominal.

b. Output Distribution Section. Disconnect P202 from J203 and replace with signal generator set at 740-mv and 100-kc. Attach VTVM across J204 and 70-ohm load. VTVM should read 350-mv nominal.

Repeat procedure for outputs #2 through #10, transferring 70-ohm load to J205 through J213, respectively.

c. Dynamic Checking Section. Turn switch S201 to OUTPUT #1 position. Attach VTVM to #3 terminal of wafer C of S201; reading should be 190-mv nominal. Attach frequency meter at same point; reading should be 1.0-mc nominal. Attach voltmeter at high end of capacitor C268 and press CAL switch S202 down. Reading should be 0.7 VDC nominal. With switch S202 released reading should be 1.1 VDC nominal.

SECTION 6

MAINTENANCE

6-1. INTRODUCTION.

Maintenance may be divided into three categories: operator's maintenance, preventive maintenance, and corrective maintenance. Operator's maintenance is presented in Section 3. Corrective maintenance may be considered as consisting of information useful in locating and diagnosing troubles and maladjustments, existing and/or pending, and information necessary to remedy the troubles and maladjustments. For reasons stated in Section 5, the remedial type of information is presented under corrective maintenance (Section 6) while the diagnosis of information is presented under trouble-shooting (Section 5).

The LMC-10 is designed to provide long-term, trouble-free operation under continuous duty conditions. Any necessary maintenance should be performed by a competent maintenance technician. If trouble cannot be corrected by following the procedures discussed in this section, it is recommended that the LMC-10 be returned to Technical Materiel Corporation for servicing. To expedite the return of the serviced equipment to you, it is recommended that the equipment be shipped to us by Air Freight and that we be authorized to return it in the same way.

6-2. PREVENTIVE MAINTENANCE.

a. In order to prevent failure of the LMC-10 due to corrosion, tube failure, dust, or other destructive elements, it is suggested that a schedule of preventive maintenance be set up and adhered to.

b. At periodic intervals (at least every six months) the LMC-10 should be removed from the relay rack for cleaning and inspection. All accessible covers should be removed and the wiring and all components inspected for dust, corrosion, charring, discoloring, or grease; in particular, the tube sockets should be carefully inspected for deterioration. Dust may be removed with a soft brush or a vacuum cleaner if one is available. Remove dirt or grease from electrical parts with trichlorethylene. Remove dirt or grease from other parts with any good dry cleaning fluid.

WARNING

When using trichlorethylene, make certain that adequate ventilation exists. Avoid prolonged contact with skin.

c. While the LMC-10 is out of the relay rack and covers are removed, check the tubes, all of which are accessible from the top of the amplifier chassis.

CAUTION

Tubes should be removed and checked one at a time to eliminate the chance of replacing a tube in the wrong socket. Do not fail to replace tube shields.

d. Carefully inspect for loose solder connections or screws, especially those on solder lugs. Recommended time interval is every 6 to 12 months, depending on the amount of vibration encountered in service.

6-3. CORRECTIVE MAINTENANCE.

WARNING

The LMC-10 utilizes voltages that may be dangerous to life, or may damage test equipment. Use care while performing corrective maintenance.

a. General. The corrective maintenance procedure presented below is essentially Technical Materiel Corporation's factory alignment procedure. Locate faulty components by the general procedure discussed in Section 5. Refer to Section 7 to determine the part numbers of replacement parts.

b. Alignment of Preamplifier (Adjustment of R201).

NOTE

Align the preamplifier whenever either or both preamplifier tubes are replaced.

Adjust balance control potentiometer R201 as follows:

(1) Arrange a test setup as shown in figure 6-1. Connect the 2.2-K ohms 1/2 watt resistor in series with the input of the receiver and pin 3 of transformer T202 (available at J202).

(2) Inject 2 signals (A) 250, 000-uv at 1.1-mc and (B) 250, 000-uv, 30% modulated 400-cps at 0.5-mc to J201, through the shielded resistive network shown.

(3) Tune receiver to 1.6-mc. Adjust balance control potentiometer R201 for maximum output (minimum cross-modulation).

(4) Lock R201.

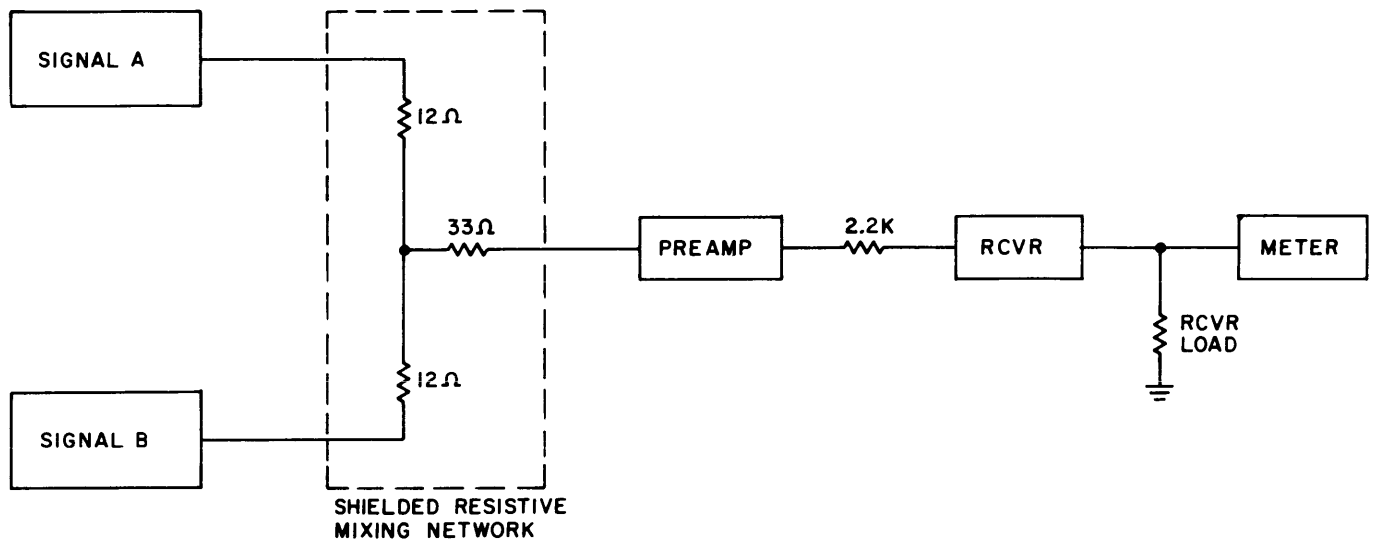

8001A-18

Figure 6-1. Block Diagram, Preamplifier Alignment Setup

c. Alignment of Distribution Lines DS201 and DS202 (Adjustment of C202, C203, C208, etc.).

NOTE

Realignment of the distribution lines should only be required after a major repair or change of a distribution line or trimmer capacitors.

The alignment procedure for distribution lines DS201 and DS202 is as follows:

- (1) Disconnect the antenna cable at J201.
- (2) Set OUTPUTS/FILTER switch to FILTER IN position.
- (3) Load outputs J203 through J213 with one capacitor each, having a value of approximately 68-uuf.
- (4) Check each output with a VTVM for presence of a signal. Deflection of the meter indicates that one or more of the output stages is oscillating. If no deflection of the meter at an output is observed, no adjustment of that output is required. If a deflection is observed, connect the meter to the output stage having the highest output level. Adjust each line trimmer C202, C203, C208, C209, C214, C215, C220, C221, C226, C227, C232, C233, C238, C239, C244, C245, C250, C251, C256, and C257 for zero indication on the VTVM, as follows: Adjust each trimmer, in turn,

by not more than 180° in either direction. If no change in meter reading is noted, as each trimmer is adjusted, reset trimmer to its previous setting, and proceed to the next trimmer.

(5) Check all outputs for zero indication, and if necessary, repeat steps (4) and (5), above.

(6) Disconnect load capacitors.

(7) If a VTVM is available, use the internal 1-mc oscillator. Adjust the line trimmers until all readings fall within the green sector of the LOADED/UNLOADED METER.

d. Alignment of Dynamic Checking Section (Adjustment of R242 and C267). Adjustments of potentiometer R242 and trimmer C267 are made only to calibrate LOADED/UNLOADED meter M201 to the particular receivers fed by the LMC-10. This procedure is discussed in Section 2.

CAUTION

Do not indiscriminately replace tubes in the LMC 10. When searching for faulty tubes, replace a tube with a new one, but if there is not a marked improvement in performance of the LMC-10, replace the old tube in its original socket. In this way, a tube that has passed a critical operating life is not replaced by a new tube with indefinite operating life.

SECTION 7 PARTS LIST

INTRODUCTION

Reference designations have been assigned to identify all maintenance parts of the equipment. They are used for marking the equipment (adjacent to the part they identify) and are included on drawings, diagrams and the parts list. The letters of a reference designation indicate the kind of part (generic group), such as a resistor, amplifier, electron tube, etc. The number differentiates between parts of the same generic group. Sockets associated with a particular plug-in device, such as electron tube or fuse, are identified by reference designations which include the

reference designations of the plug-in device. For example, the socket for tube V201 is designated XV201. Column 1 of the parts lists gives reference designations of the parts in alphabetical and numerical order. Column 2 gives the name and describes the various parts. Major part assemblies are listed in their entirety; subparts of a major assembly are listed in alphabetical and numerical order with reference to its major assembly. Column 3 indicates how the part is used within a major component. Column 4 lists each Technical Materiel Corporation part number.

LMC-10-70/U ANTENNA MULTICOUPLER

DESCRIPTION	FUNCTION	TMC DWG. OR PART NO.
Distributive Amplifier		DA-101-70/U
Power Supply		PS-7
Cable Assembly	Distributive Amplifier to Power Supply	CA-10133
Cable Assembly	AC Power Cord	CA-10125
Plug, Female, Right Angle (P/O CA-10133)	Mates with J214 on DA-101-70/U	MS3108B16S-1S
Plug, Male, Straight (P/O CA-10133)	Mates with J102 on PS-7	MS3106B16S-1P
Plug, Female, AC Polarized, twistlock (P/O CA-10125)	Mates with J101 on PS-7	PL-176
Plug, Male, AC Polarized, (P/O CA-10125)	Connection to Line Voltage	PL-172
Plug, Coaxial, Type PL-259, 50-ohm	Mating connectors for J204 through J214 on DA-101-70/U	PL-259

LMC-10-70/U ANTENNA MULTICOUPLER
DA-101-70/U DISTRIBUTIVE AMPLIFIER

SYM.	DESCRIPTION	FUNCTION	TMC DWG. OR PART NO.
C201	CAPACITOR: fixed ceramic, 0.01 uf, $\pm 10\%$, 600 VDCW	B+ Decoupling Capacitor	CC-10002-1
C202	CAPACITOR: variable, air, 6.4 uuf	Tuning Element of Delay Line	CB-10001-1
C203	Same as C202.	Same as C202.	
C204	Same as C201.	Plate Decoupling Capacitor	
C205	Same as C201.	Same as C204.	
C206	Same as C201.	Cathode Bypass Capacitor	
C207	Same as C201.	P/O Meter Circuit RF Filter	
C208	Same as C202.	Same as C202.	
C209	Same as C202.	Same as C202.	
C210	Same as C201.	Same as C204.	
C211	Same as C201.	Same as C204.	
C212	Same as C201.	Same as C206.	
C213	Same as C201.	Same as C207.	
C214	Same as C202.	Same as C202.	
C215	Same as C202.	Same as C202.	
C216	Same as C201.	Same as C204.	
C217	Same as C201.	Same as C204.	
C218	Same as C201.	Same as C206.	
C219	Same as C201.	Same as C207.	
C220	Same as C202.	Same as C202.	
C221	Same as C202.	Same as C202.	
C222	Same as C201.	Same as C204.	
C223	Same as C201.	Same as C204.	
C224	Same as C201.	Same as C206.	
C225	Same as C201.	Same as C207.	
C226	Same as C202.	Same as C202.	
C227	Same as C202.	Same as C202.	

**LMC-10-70/U ANTENNA MULTICOUPLER
DA-101-70/U DISTRIBUTIVE AMPLIFIER**

SYM.	DESCRIPTION	FUNCTION	TMC DWG. OR PART NO.
C228	Same as C201.	Same as C204.	
C229	Same as C201.	Same as C204.	
C230	Same as C201.	Same as C206.	
C231	Same as C201.	Same as C207.	
C232	Same as C202.	Same as C202.	
C233	Same as C202.	Same as C202.	
C234	Same as C201.	Same as C204.	
C235	Same as C201.	Same as C204.	
C236	Same as C201.	Same as C206.	
C237	Same as C201.	Same as C207.	
C238	Same as C202.	Same as C202.	
C239	Same as C202.	Same as C202.	
C240	Same as C201.	Same as C204.	
C241	Same as C201.	Same as C204.	
C242	Same as C201.	Same as C206.	
C243	Same as C201.	Same as C207.	
C244	Same as C202.	Same as C202.	
C245	Same as C202.	Same as C202.	
C246	Same as C201.	Same as C204.	
C247	Same as C201.	Same as C204.	
C248	Same as C201.	Same as C206.	
C249	Same as C201.	Same as C207.	
C250	Same as C202.	Same as C202.	
C251	Same as C202.	Same as C202.	
C252	Same as C201.	Same as C204.	
C253	Same as C201.	Same as C204.	
C254	Same as C201.	Same as C206.	
C255	Same as C201.	Same as C207.	
C256	Same as C202.	Same as C202.	
C257	Same as C202.	Same as C202.	

**LMC-10-70/U ANTENNA MULTICOUPLER
DA-101-70/U DISTRIBUTIVE AMPLIFIER**

SYM.	DESCRIPTION	FUNCTION	TMC DWG. OR PART NO.
C258	Same as C201.	Same as C204.	
C259	Same as C201.	Same as C204.	
C260	Same as C201.	Same as C206.	
C261	Same as C201.	Same as C207.	
C262	Same as C201.	Same as C204.	
C263	CAPACITOR: fixed, ceramic, 1000 uuf + 50% -20%, 500 wvdc.	DC Plate Blocking	CC-10005
C264	CAPACITOR: fixed, ceramic, 15 uuf ± 5%, 500 wvdc.	RF Bypass Capacitor	CC-10003-7
C265	CAPACITOR: fixed, ceramic, 1.5 uuf ± 0.25 uuf, 500 wvdc.	RF Coupling Capacitor	CC-10003-6
C266	CAPACITOR: fixed, mica, ^{1.50} 100 uuf ± 2%, 500 wvdc, char. C.	DC Cathode Blocking Capacitor	^{D.S.J.K.} CM20C101G
C267	CAPACITOR: variable, ceramic, 4-30 uuf, char. C.	Same as C266.	CV11C300
C268	Same as C201.	Same as C207.	
C269	Same as C201.	Heater Bypass Capacitor	
C270	Same as C201.	Heater Decoupling Capacitor	
C271	Same as C201.	B+ Decoupling Capacitor	
C272	Same as C201.	Same as C271.	
C273	Same as C201.	Pilot Lamp Bypass Capacitor	
C274	Same as C201.	Same as C270.	
C275	Same as C201.	Same as C270.	
CR201	DIODE: germanium	RF Rectifier	⁴⁷⁸ 1N55A
CR202	Same as CR201.	Same as CR201.	
CR203	Same as CR201.	Same as CR201.	
CR204	Same as CR201.	Same as CR201.	
CR205	Same as CR201.	Same as CR201.	
CR206	Same as CR201.	Same as CR201.	
CR207	Same as CR201.	Same as CR201.	

**LMC-10-70/U ANTENNA MULTICOUPLER
DA-101-70/U DISTRIBUTIVE AMPLIFIER**

SYM.	DESCRIPTION	FUNCTION	TMC DWG. OR PART NO.
CR208	Same as CR201.	Same as CR201.	
CR209	Same as CR201.	Same as CR201.	
CR210	Same as CR201.	Same as CR201.	
CR211	CRYSTAL: quartz, 1-mc \pm .005%, plug-in type	p/o 1-Mc Oscillator	CR18/U-1.000-P
CR212	Same as CR201.	Same as CR201.	
DL201	DELAY LINE: artificial, composed of inductive elements, capacitive element, input capacitance of tubes V203, V205, V207, V209, V211, V213, V215, V217, V219, V221, and stray capacitance	Distribution System Between Preamplifier and Output Stages	DL-10007
DL202	DELAY LINE: artificial, composed of inductive elements, capacitive elements, input capacitances of tubes V204, V206, V208, V210, V212, V214, V216, V218, V220, V222, and stray capacitance	Same as DL201	DL-10007
I201	LAMP: incandescent, bayonet base, 6-8 V, 0.15 a. T-3-1/4 bulb	POWER light	BI-101-47
J201	CONNECTOR: female, coaxial, single conductor, type SO-239, UHF series	Antenna Input Jack	SO-239
J202	CONNECTOR: female, coaxial, BNC series, single conductor	Preamplifier Output Jack	UG-625 B/U
J203	Same as J202.	Line Driver Input Jack	
J204	Same as J201.	Output Jack	
J205	Same as J201.	Same as J204.	
J206	Same as J201.	Same as J204.	
J207	Same as J201.	Same as J204.	
J208	Same as J201.	Same as J204.	
J209	Same as J201.	Same as J204.	
J210	Same as J201.	Same as J204.	
J211	Same as J201.	Same as J204.	
J212	Same as J201.	Same as J204.	
J213	Same as J201.	Same as J204.	
J214	CONNECTOR: male, MS type, 7-pin chassis mounting	Power Input Connector	MS3102A-16S-1P

**LMC-10-70/U ANTENNA MULTICOUPLER
DA-101-70/U DISTRIBUTIVE AMPLIFIER**

SYM.	DESCRIPTION	FUNCTION	TMC DWG. OR PART NO.
L201	INDUCTANCE: consisting of 1/2 inch of no. 22 buss wire fitted with four ferrite beads, 2 μ hy total	p/o Heater Line Decoupling Network	CI-10008*
L202	Same as L201.	Same as L201.	
M201	METER: 25 ua, special scale, model 27	Dynamic Check Indicator	MR-10001-1
P201	PLUG: coaxial, type UG-260/U, 50-ohm (p/o CA-10114)		UG-260/U
P202	Same as P201.		
R201	RESISTOR: variable, molded composition, 50 ohms \pm 10%, 2W, linear taper, locking type	Balancing Potentiometer	RV4LAYSA-500A
R202	RESISTOR: fixed, composition, 18 ohm \pm 5%, 1 W	Cathode Bias Resistor	RC32GF180J
R203	RESISTOR: fixed, composition, 680 ohm \pm 5%, 1 W	Plate Decoupling Resistor	RC32GF681J
R204	RESISTOR: fixed, film, 430 ohm \pm 1%, 1 W	Same as R202.	RN75B4300F
R205	RESISTOR: fixed, composition, 1000 ohm \pm 5%, 1/2 watt.	Isolation Resistor	RG20GF102J
R206	Same as R203.	Same as R203.	
R207	Same as R204.	Same as R202.	
R208	Same as R205.	Same as R205.	
R209	Same as R203.	Same as R203.	
R210	Same as R204.	Same as R202.	
R211	Same as R205.	Same as R205.	
R212	Same as R203.	Same as R203.	
R213	Same as R204.	Same as R202.	
R214	Same as R205.	Same as R205.	
R215	Same as R203.	Same as R203.	
R216	Same as R204.	Same as R202.	
R217	Same as R205.	Same as R205.	
R218	Same as R203.	Same as R203.	
R219	Same as R204.	Same as R202.	

*Part number of ferrite bead only. Do not substitute 2 μ hy coil for this arrangement.

**LMC-10-70/U ANTENNA MULTICOUPLER
DA-101-70/U DISTRIBUTIVE AMPLIFIER**

SYM.	DESCRIPTION	FUNCTION	TMC DWG. OR PART NO.
R220	Same as R205.	Same as R205.	
R221	Same as R203.	Same as R203.	
R222	Same as R204.	Same as R202.	
R223	Same as R205.	Same as R205.	
R224	Same as R203.	Same as R203.	
R225	Same as R204.	Same as R202.	
R226	Same as R205.	Same as R205.	
R227	Same as R203.	Same as R203.	
R228	Same as R204.	Same as R202.	
R229	Same as R205.	Same as R205.	
R230	Same as R203.	Same as R203.	
R231	Same as R204.	Same as R202.	
R232	Same as R205.	Same as R205.	
R233	RESISTOR: fixed, film, 510 ohm $\pm 1\%$, 1/2 watt.	Delay Line Termination Resistor	RN70B5100F
R234	Same as R233.	Same as R233	
R235	RESISTOR: fixed, composition, 100,000 ohm $\pm 10\%$, 1/2 watt.	Same as R203	RC20GF104K
R236	RESISTOR: fixed, composition, 470,000 ohm $\pm 10\%$, 1/2 watt.	Grid Return Resistor	RC20GF474K
R237	RESISTOR: fixed, composition, 2,200 ohm $\pm 5\%$, 1/2 watt.	Same as R202.	RC20GF222J
R238	Same as R236.	Same as R236.	
R239	RESISTOR: fixed, composition, 270 ohm $\pm 5\%$, 1/2 watt.	Same as R202.	RC20GF271J
R240	Same as R237.	Load Resistor	
R241	RESISTOR: fixed, composition, 8,200 ohm $\pm 5\%$, 1/2 watt.	Same as R240.	RC20GF822J
R242	RESISTOR: variable, composition, 50,000 ohm $\pm 20\%$, 1/2 watt.	CAL ADJUST	RV-10002-9
S201	SWITCH: rotary, 4 section, 12 position, ceramic wafer.	FILTER-OUTPUT Switch	SW-10018

LMC-10-70/U ANTENNA MULTICOUPLER
DA-101-70/U DISTRIBUTIVE AMPLIFIER

SYM.	DESCRIPTION	FUNCTION	TMC DWG. OR PART NO.
S202	SWITCH: toggle, on-none-momentary contact, dpdt.	CALIBRATE Switch	SW-10020
T201	TRANSFORMER: input, broadband, 0.1-2 mc; primary: terminal 6 60-ohms unbalanced, terminal 1 ground secondary: terminal 2 and 5 center tap, terminal 3 and 4 60-ohms balanced.	Input Matching Transformer	TR086
T202	TRANSFORMER: preamplifier output, broadband, 0.1-2 mc; primary: terminal 5 and 7 1000-ohms balanced either side, terminal 6 B+; secondary; terminals 3 70-ohms unbalanced, terminal 1 ground.	Preamplifier Output Matching Transformer	TR084
T203	TRANSFORMER: line driver, broadband 0.1-2 mc; primary: terminal 1 70-ohms unbalanced, terminal 7 ground secondary terminal 3 and 5 510-ohms balanced either side, terminal 4, ground.	Distribution Line Driving Transformer	TR085
T204	TRANSFORMER: output, broadband, 0.1-2 mc; primary: terminal 3 and 5 1000-ohms balanced either side, terminal 4 center tap; secondary terminal 7 70-ohms unbalanced, terminal 1 ground.	Output Matching Transformer	TR087
T205	Same as T204.	Same as T204.	
T206	Same as T204.	Same as T204.	
T207	Same as T204.	Same as T204.	
T208	Same as T204.	Same as T204.	
T209	Same as T204.	Same as T204.	
T210	Same as T204.	Same as T204.	
T211	Same as T204.	Same as T204.	
T212	Same as T204.	Same as T204.	
T213	Same as T204.	Same as T204.	
V201	TUBE: electron, triode, receiving type, 9-pin miniature.	Preamplifier	5842/417A
V202	Same as V201.	Same as V201.	
V203	TUBE: electron, triode, receiving type, 7-pin miniature.	Cathode Follower	6C4
V204	Same as V203.	Same as V203.	
V205	Same as V203.	Same as V203.	
V206	Same as V203.	Same as V203.	
V207	Same as V203.	Same as V203.	
V208	Same as V203.	Same as V203.	

**LMC-10-70/U ANTENNA MULTICOUPLER
DA-101-70/U DISTRIBUTIVE AMPLIFIER**

SYM.	DESCRIPTION	FUNCTION	TMC DWG. OR PART NO.
V209	Same as V203.	Same as V203.	
V210	Same as V203.	Same as V203.	
V211	Same as V203.	Same as V203.	
V212	Same as V203.	Same as V203.	
V213	Same as V203.	Same as V203.	
V214	Same as V203.	Same as V203.	
V215	Same as V203.	Same as V203.	
V216	Same as V203.	Same as V203.	
V217	Same as V203.	Same as V203.	
V218	Same as V203.	Same as V203.	
V219	Same as V203.	Same as V203.	
V220	Same as V203.	Same as V203.	
V221	Same as V203.	Same as V203.	
V222	Same as V203.	Same as V203.	
V223	TUBE: electron, dual-triode, receiving type, 9-pin miniature.	1-Mc Oscillator	6922/6DJ8
W201	CABLE ASSEMBLY: coaxial.	Antenna Input to S201A	CA-10124-1
W202	CABLE ASSEMBLY: coaxial.	J202 to J203	CA-10114
W203	CABLE ASSEMBLY: coaxial.	T204 to OUTPUT #1	CA-10124-2
W204	Same as W203.	T205 to OUTPUT #2	
W205	Same as W203.	T206 to OUTPUT #3	
W206	Same as W203.	T207 to OUTPUT #4	
W207	Same as W203.	T208 to OUTPUT #5	
W208	Same as W203.	T209 to OUTPUT #6	
W209	Same as W203.	T210 to OUTPUT #7	
W210	Same as W203.	T211 to OUTPUT #8	

LMC-1070/U ANTENNA MULTICOUPLER
DA-10170/U DISTRIBUTIVE AMPLIFIER

SYM.	DESCRIPTION	FUNCTION	TMC DWG. OR PART NO.
W211	Same as W203.	T212 to OUTPUT #9	
W212	Same as W203.	T213 to OUTPUT #10	
XCR211	SOCKET: crystal	Socket, CR211	TS-104-2
XI201	SOCKET: redlens, for miniature bayonet base, T-3-1/4 bulb.	Socket, I201	TS-106-1
XV201	SOCKET: tube, 9-pin miniature.	Socket, V201	TS-103-P01
XV202	Same as XV201.	Socket, V202	
XV203	SOCKET: tube, 9-pin, miniature.	Socket, V203	TS-102-P01
XV204	Same as XV203.	Socket, V204	
XV205	Same as XV203.	Socket, V205	
XV206	Same as XV203.	Socket, V206	
XV207	Same as XV203.	Socket, V207	
XV208	Same as XV203.	Socket, V208	
XV209	Same as XV203.	Socket, V209	
XV210	Same as XV203.	Socket, V210	
XV211	Same as XV203.	Socket, V211	
XV212	Same as XV203.	Socket, V212	
XV213	Same as XV203.	Socket, V213	
XV214	Same as XV203.	Socket, V214	
XV215	Same as XV203.	Socket, V215	
XV216	Same as XV203.	Socket, V216	
XV217	Same as XV203.	Socket, V217	
XV218	Same as XV203.	Socket, V218	
XV219	Same as XV203.	Socket, V219	
XV220	Same as XV203.	Socket, V220	
XV221	Same as XV203.	Socket, V221	
XV222	Same as XV203.	Socket, V222	
XV223	Same as XV201.	Socket, V223	
Z201	FILTER: lowpass 2-mc cutoff frequency, input impedance 70-ohms; unbalanced terminal 4 output impedance 70-ohms; unbalanced terminal 2; ground terminal 1. 3.	Attenuation above 2-mc	FX10011

M. 51w4

LMC-10-70/U ANTENNA MULTICOUPLER
POWER SUPPLY PS-7

SYM.	DESCRIPTION	FUNCTION	TMC DWG. OR PART NO.
C101	CAPACITOR: fixed, paper, oil filled, 0.02 uf, +40% -20%, 600 wvdc.	AC Line Filter Capacitor	CN-100-17
C102	Same as C101.	Same as C101.	
C103	CAPACITOR: fixed, electrolytic, 80 uf, 450 wvdc, plug-in type.	DC Power Supply Filter Capacitor	CE51F800R
CR101	DIODE: germanium	Rectifier	1N1084
CR102	Same as CR101	Same as CR101.	
CR103	Same as CR101.	Same as CR101.	
CR104	Same as CR101.	Same as CR101.	
CR105	Same as CR101.	Same as CR101.	
CR106	Same as CR101.	Same as CR101.	
CR107	Same as CR101.	Same as CR101.	
CR108	Same as CR101.	Same as CR101.	
CR109	DIODE: zener, 150v.	Voltage Regulator	1N2843
F101	FUSE: cartridge, slow blow, 1.25 amp., 250 V (one fuse spare).	Primary Power Fuse	FU-102-1.25
I101	LAMP: incandescent, bayonet base, 6-8v, 0.15 amp., T-3-1/4 bulb brown.	Pilot Light	BI-101-47
J101	RECEPTACLE: male, twistlock, polarized, 250 vac, 10 amp.	AC Power Receptacle	JJ-175
J102	CONNECTOR: female, 7-pin chassis mounting.	Receptacle Interconnect Cable	MS3102A-16S-1S
L101	CHOKE: filter, inductance 10 hy. at 30 vrms, 60 cps for 300 ma dc; winding resistance 85-ohms, insulated for 300 wvdc; hermetically sealed steel case.	p/o DC Power Supply Filter	TR-10010
R101	RESISTOR: fixed, wirewound, 2000 ohms, 10w.	Series Dropping Resistor	RW-109-28
S101	SWITCH: toggle, dpdt, 1 amp., 250 V, 28 degrees.	Power Switch	ST-22K
T101	TRANSFORMER: power, single phase; primary: 115-230 v, 60 cps; three secondary windings, high tension winding, center tapped, 300-0-300 wvdc, 300 ma dc rating; filament winding 6.3 v, 4 a; electrostatic shield, hermetically sealed steel case.	Power Transformer	TF-10008
XC103	SOCKET: octal, lowcrown.	Socket, C103	TS-101-P01

**LMC-10,70/U ANTENNA MULTICOUPLER
POWER SUPPLY PS-7**

m 5 3 1 2 4 7

SYM.	DESCRIPTION	FUNCTION	TMC DWG. OR PART NO.
XCR101	MOUNTING BLOCK: rectifier polar.	Holder, CR101	CU128
XCR102	Same as XCR101.	Holder, CR102	
XCR103	Same as XCR101.	Holder, CR103	
XCR104	Same as XCR101.	Holder, CR104	
XCR105	Same as XCR101.	Holder, CR105	
XCR106	Same as XCR101.	Holder, CR106	
XCR107	Same as XCR101.	Holder, CR107	
XCR108	Same as XCR101.	Holder, CR108	
XF101	HOLDER: fuse, lamp indicating; lamp type neon.	Fuseholder	FH-104-3
XI101	SOCKET: red lens, for miniature bayonet base using T-3-1/4 bulb.	Socket for I101	TS-106-1

Blank

SECTION 8
SCHEMATIC DIAGRAMS

MISSING

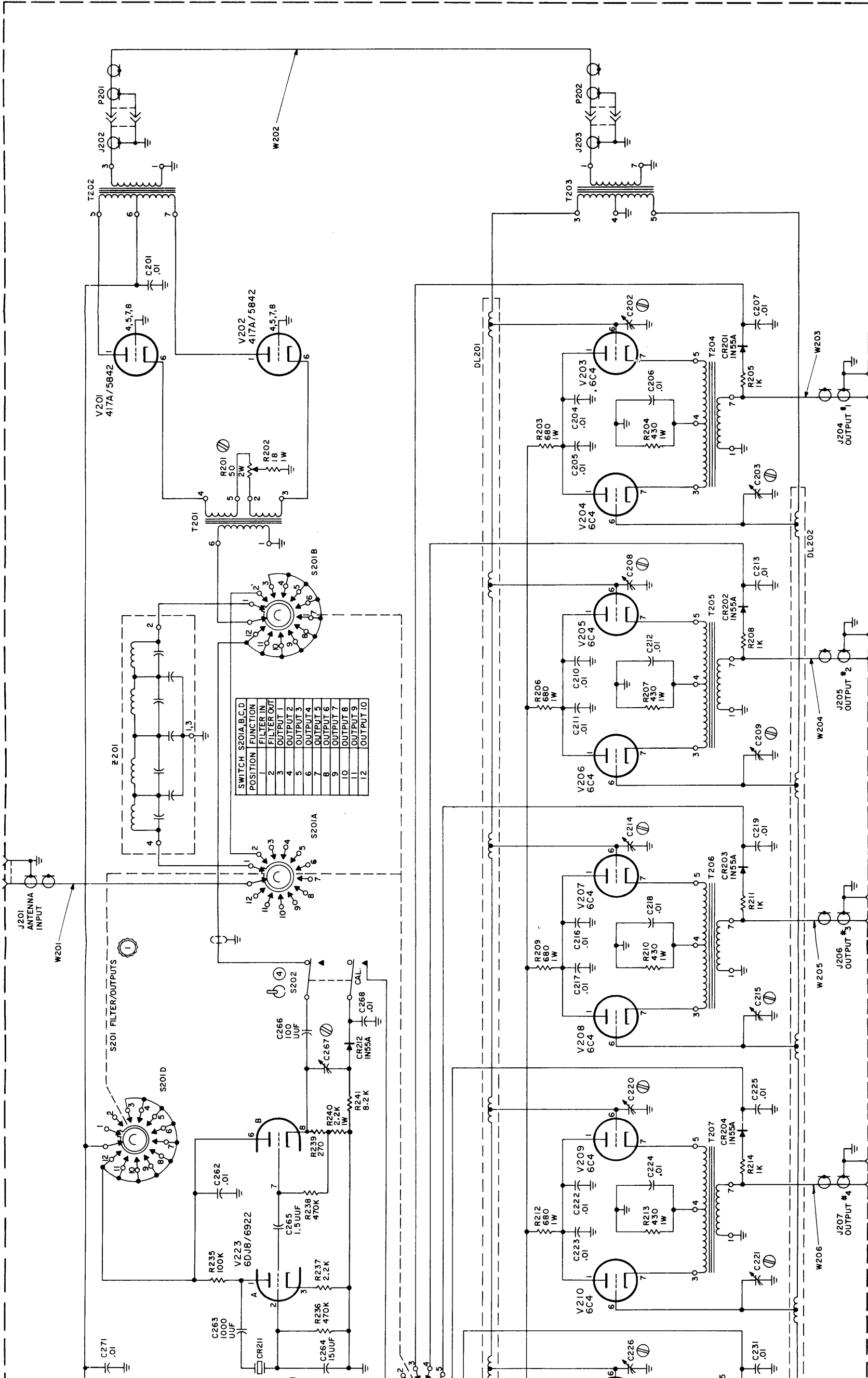

NOTES:
 1- SEE FIGURE 3-1 FOR LOCATION OF NUMBERED CONTROLS ON PANEL.
 2- UNLESS OTHERWISE NOTED: ALL RESISTORS ARE 1/2 WATT. ALL CAPACITOR VALUES ARE IN UF. ALL COIL VALUES ARE IN UH.
 3- Ⓞ INDICATES SCREWDRIVER CONTROL ON CHASSIS.

Figure 8-1. Schematic Diagram, Distributive Amplifier, DA-101-70/U

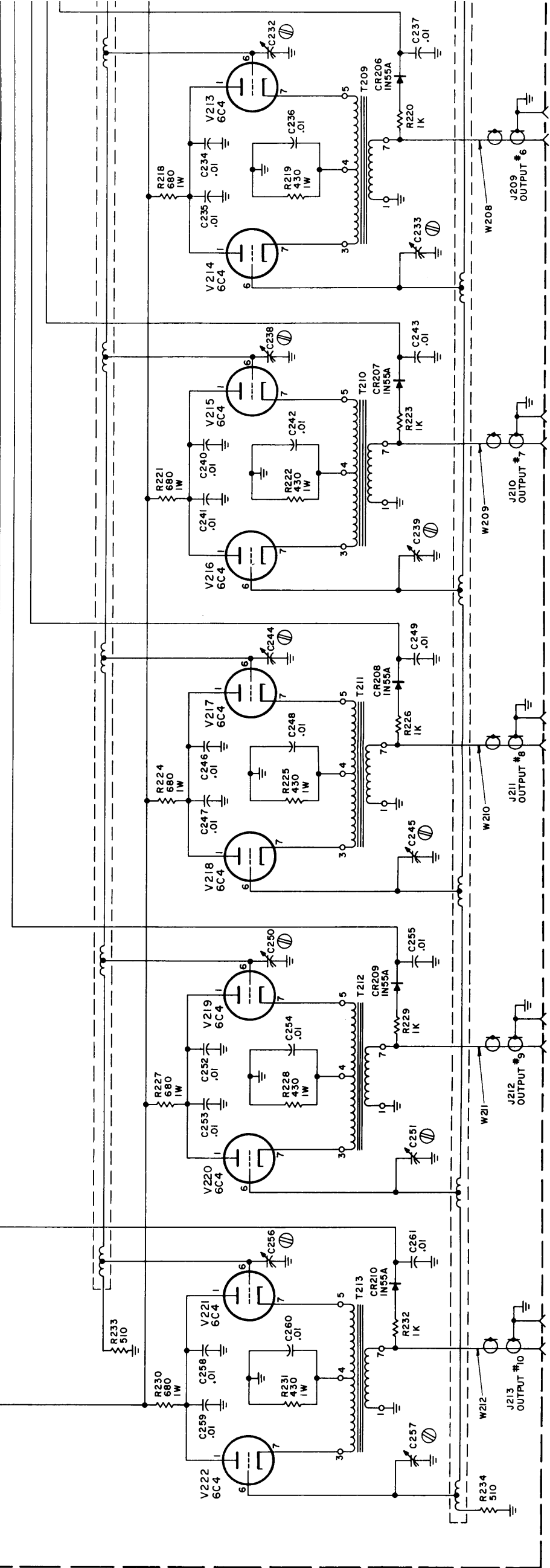
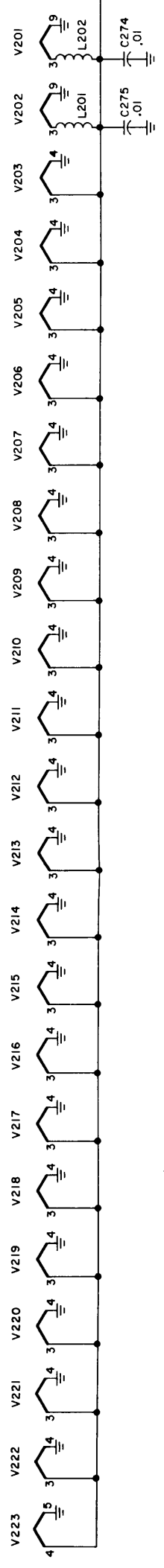

8001A-19

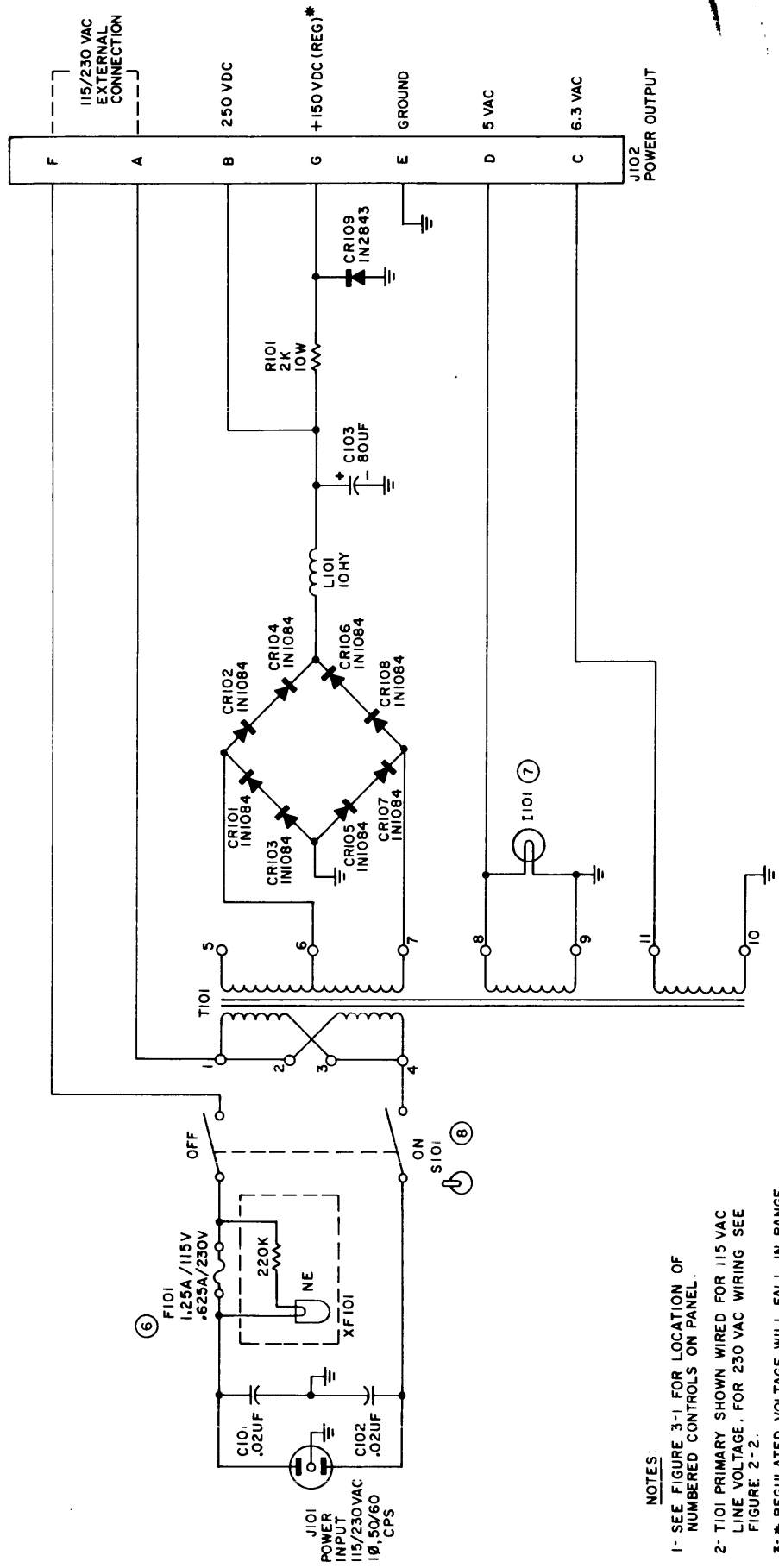

- NOTES:
- 1- SEE FIGURE 3-1 FOR LOCATION OF NUMBERED CONTROLS ON PANEL.
 - 2- T101 PRIMARY SHOWN WIRED FOR 115 VAC LINE VOLTAGE. FOR 230 VAC WIRING SEE FIGURE 2-2.
 - 3- * REGULATED VOLTAGE WILL FALL IN RANGE OF 150 VDC ± 10% DEPENDING ON LOAD CONDITIONS.

Figure 8-2. Schematic Diagram, Power Supply, PS-7