

UNCLASSIFIED

(NavShips 0967-035-6010)

TECHNICAL MANUAL

for

TERMINAL, TELEGRAPH
TH-39B/UGT

DEPARTMENT OF THE NAVY

BUREAU OF SHIPS

UNCLASSIFIED

UNCLASSIFIED

(NavShips 0967-035-6010)

TECHNICAL MANUAL

for

TERMINAL, TELEGRAPH
TH-39B/UGT

DEPARTMENT OF THE NAVY

BUREAU OF SHIPS

UNCLASSIFIED

Publication: 1 January 1965



THE TECHNICAL MATERIEL CORPORATION

C O M M U N I C A T I O N S E N G I N E E R S

700 FENIMORE ROAD

MAMARONECK, N. Y.

W a r r a n t y

The Technical Materiel Corporation, hereinafter referred to as TMC, warrants the equipment (except electron tubes,*fuses, lamps, batteries and articles made of glass or other fragile or other expendable materials) purchased hereunder to be free from defect in materials and workmanship under normal use and service, when used for the purposes for which the same is designed, for a period of one year from the date of delivery F.O.B. factory. TMC further warrants that the equipment will perform in a manner equal to or better than published technical specifications as amended by any additions or corrections thereto accompanying the formal equipment offer.

TMC will replace or repair any such defective items, F.O.B. factory, which may fail within the stated warranty period, PROVIDED:

1. That any claim of defect under this warranty is made within sixty (60) days after discovery thereof and that inspection by TMC, if required, indicates the validity of such claim to TMC's satisfaction.
2. That the defect is not the result of damage incurred in shipment from or to the factory.
3. That the equipment has not been altered in any way either as to design or use whether by replacement parts not supplied or approved by TMC, or otherwise.
4. That any equipment or accessories furnished but not manufactured by TMC, or not of TMC design shall be subject only to such adjustments as TMC may obtain from the supplier thereof.

Electron tubes*furnished by TMC, but manufactured by others, bear only the warranty given by such other manufacturers. Electron tube warranty claims should be made directly to the manufacturer of such tubes.

TMC's obligation under this warranty is limited to the repair or replacement of defective parts with the exceptions noted above.

At TMC's option any defective part or equipment which fails within the warranty period shall be returned to TMC's factory for inspection, properly packed with shipping charges prepaid. No parts or equipment shall be returned to TMC, unless a return authorization is issued by TMC.

No warranties, express or implied, other than those specifically set forth herein shall be applicable to any equipment manufactured or furnished by TMC and the foregoing warranty shall constitute the Buyers sole right and remedy. In no event does TMC assume any liability for consequential damages, or for loss, damage or expense directly or indirectly arising from the use of TMC Products, or any inability to use them either separately or in combination with other equipment or materials or from any other cause.

*Electron tubes also include semi-conductor devices.

PROCEDURE FOR RETURN OF MATERIAL OR EQUIPMENT

Should it be necessary to return equipment or material for repair or replacement, whether within warranty or otherwise, a return authorization must be obtained from TMC prior to shipment. The request for return authorization should include the following information:

1. Model Number of Equipment.
2. Serial Number of Equipment.
3. TMC Part Number.
4. Nature of defect or cause of failure.
5. The contract or purchase order under which equipment was delivered.

PROCEDURE FOR ORDERING REPLACEMENT PARTS

When ordering replacement parts, the following information must be included in the order as applicable:

1. Quantity Required.
2. TMC Part Number.
3. Equipment in which used by TMC or Military Model Number.
4. Brief Description of the Item.
5. The *Crystal Frequency* if the order includes crystals.

PROCEDURE IN THE EVENT OF DAMAGE INCURRED IN SHIPMENT

TMC's Warranty specifically excludes damage incurred in shipment to or from the factory. In the event equipment is received in damaged condition, the carrier should be notified immediately. Claims for such damage should be filed with the carrier involved and not with TMC.

All correspondence pertaining to Warranty Claims, return, repair, or replacement and all material or equipment returned for repair or replacement, within Warranty or otherwise, should be addressed as follows:

THE TECHNICAL MATERIEL CORPORATION
Engineering Services Department
700 Fenimore Road
Mamaroneck, New York

CHANGE NO. 1 TIS-3A



INSTRUCTION BOOK CHANGE NOTICE

Date 2/18/65

Manual affected: Tone Intelligence Unit, Model TIS-3A IN -2025

Page 4-2, paragraph 4-4, third sentence:

Change third sentence to read: The output of a crystal selected by the CENTER FREQUENCY switch S6 is applied to crystal oscillator V8, which is coupled by a broadband tuned tank (L6) to the grids of mixer V5 and the primary of transformer T4.

Page 4-2, paragraph 4-5, sixth sentence:

Change grids to grid.

Page 4-2, paragraph 4-5, last sentence:

Change grid to grids.

Page 7-5, Parts List:

Change TMC PART NO. for R57 from RC20GF221K to RC20GF221J

EMN 13334

SHOULD ADDITIONAL COPIES OF THIS CHANGE NOTICE BE REQUIRED, PLEASE CONTACT:

THE TECHNICAL MATERIEL CORP., 700 Fenimore Road, Mamaroneck, New York

Attn.: Director of Eng. Services.

CHANGE NO. 2 TIS-3A



INSTRUCTION BOOK CHANGE NOTICE

Date Feb. 25, 1965

Manual affected: Tone Intelligence Unit, Model TIS-3A IN 2025

Issue Date: 1 January 1965

Incorporate the following change in Section 3, paragraph 3-3 (page 3-2)

On the last line of NOTE text, change to read:

f_0 = desired tone center frequency.

SHOULD ADDITIONAL COPIES OF THIS CHANGE NOTICE BE REQUIRED, PLEASE CONTACT:

THE TECHNICAL MATERIEL CORP., 700 Fenimore Road, Mamaroneck, New York

Attn.: Director of Eng. Services.



INSTRUCTION BOOK CHANGE NOTICE

Date 10/4/65

Manual affected: Tone Intelligence Unit, Model TIS-3A IN 2025

1. Page 1-2. Table 1-1.

Change technical characteristics for FAX INPUT to read:

FAX input: 0 to +20 volts for a linear shift of 1200 cps.

2. Page 6-3. Table 6-1.

Change steps 19 and 20 of table 6-1 as follows:

STEP	ACTION	NORMAL INDICATION																
19	Place S1 in FAX position. Arrange test set-up as shown in figure 6-2. Place S6 in 1900 position. Adjust FAX BIAS potentiometer R44 for output frequency of 2500 cps when input voltage is 0.	Proper setting of FAX BIAS adjustment R44.																
20A	Adjust FAX ADJ potentiometer R66 for output frequency of 1300 cps when input voltage is +20.	Proper setting of FAX ADJ potentiometer R66.																
20B	Vary input voltage and measure output frequency. <table style="margin-left: auto; margin-right: auto;"> <thead> <tr> <th>Input Voltage</th> <th>Output Frequency</th> </tr> </thead> <tbody> <tr> <td>0</td> <td>2500 cps</td> </tr> <tr> <td>1</td> <td>2440 cps +6 cps</td> </tr> <tr> <td>2</td> <td>2380 cps +12 cps</td> </tr> <tr> <td>5</td> <td>2200 cps +30 cps</td> </tr> <tr> <td>10</td> <td>1900 cps +60 cps</td> </tr> <tr> <td>15</td> <td>1600 cps +30 cps</td> </tr> <tr> <td>20</td> <td>1300 cps</td> </tr> </tbody> </table>	Input Voltage	Output Frequency	0	2500 cps	1	2440 cps +6 cps	2	2380 cps +12 cps	5	2200 cps +30 cps	10	1900 cps +60 cps	15	1600 cps +30 cps	20	1300 cps	Checks FAX linearity.
Input Voltage	Output Frequency																	
0	2500 cps																	
1	2440 cps +6 cps																	
2	2380 cps +12 cps																	
5	2200 cps +30 cps																	
10	1900 cps +60 cps																	
15	1600 cps +30 cps																	
20	1300 cps																	

SHOULD ADDITIONAL COPIES OF THIS CHANGE NOTICE BE REQUIRED, PLEASE CONTACT:

THE TECHNICAL MATERIEL CORP., 700 Fenimore Road, Mamaroneck, New York

Attn.: Director of Eng. Services.

CHANGE NO. 3 TIS-3A (Sheet 2 of 2)



INSTRUCTION BOOK CHANGE NOTICE

Date 10/4/65

Manual affected: Tone Intelligence Unit, Model TIS-3A IN 2025

3. Delete steps 20C through 20G in Table 6-1.

SHOULD ADDITIONAL COPIES OF THIS CHANGE NOTICE BE REQUIRED, PLEASE CONTACT:

THE TECHNICAL MATERIEL CORP., 700 Fenimore Road, Mamaroneck, New York

Attn.: Director of Eng. Services.

TABLE OF CONTENTS

Paragraph	Page	Paragraph	Page
SECTION 1 — GENERAL INFORMATION		SECTION 4 — PRINCIPLES OF OPERATION (Cont'd)	
1-1	1-1	4-3	4-1
1-2	1-1	4-4	4-2
1-3	1-1	4-5	4-2
1-4	1-1	4-6	4-2
SECTION 2 — INSTALLATION		4-7	4-10
2-1	2-1	4-8	4-10
2-2	2-1	SECTION 5 — TROUBLESHOOTING	
2-3	2-1	5-1	5-1
2-4	2-1	SECTION 6 — MAINTENANCE	
SECTION 3 — OPERATOR'S SECTION		6-1	6-0
3-1	3-1	6-2	6-0
3-2	3-1	6-3	6-0
3-3	3-1	SECTION 7 — PARTS LIST	
SECTION 4 — PRINCIPLES OF OPERATION		7-1	7-0
4-1	4-1	SECTION 8 — SCHEMATIC DIAGRAMS	
4-2	4-1		

LIST OF ILLUSTRATIONS

Figure	Page	Figure	Page
SECTION 1 — GENERAL INFORMATION		SECTION 4 — PRINCIPLES OF OPERATION (CONT'D).	
1-1	1-0	4-8	4-12
1-1 Tone Intelligence Unit TIS-3A, Front Angle View		4-8 Power Supply, Simplified Schematic Diagram	
SECTION 2 — INSTALLATION		SECTION 5 — TROUBLESHOOTING	
2-1	2-1	5-1	5-3
2-2	2-1	5-2	5-4
2-3	2-2	5-3	5-4
2-1 Power Supply, Wiring Diagram		5-1 Voltage and Resistance Measurements	
2-2 Oven Wiring Diagram		5-2 Front Panel Operating Controls	
2-3 Tone Intelligence Unit TIS-3A, Installation Drawing		5-3 Top View of Chassis, Parts Location	
SECTION 3 — OPERATOR'S SECTION		5-4 Bottom View of Chassis, Parts Location	
3-1	3-1	5-5 Right View of Chassis, Parts Location	
3-1 Front Panel Operating Controls		5-6 Rear View of Chassis, Parts Location	
SECTION 4 — PRINCIPLES OF OPERATION		5-7 Terminal Boards, Parts Location	
4-1	4-3/4-4	SECTION 6 — MAINTENANCE	
4-2	4-5	6-1	6-5
4-3	4-6	6-2	6-5
4-4	4-7	6-3	6-5
4-5	4-8	6-1 Test Setup No. 1	
4-6	4-9	6-2 Test Setup No. 2	
4-7	4-11	6-3 Test Setup No. 3	
4-1 Tone Intelligence Unit TIS-3A, Overall Block Diagram		SECTION 8 — SCHEMATIC DIAGRAMS	
4-2 First Keyer, Simplified Schematic Diagram		8-1	8-3/8-4
4-3 Second Keyer, Simplified Schematic Diagram		8-1 Tone Intelligence Unit TIS-3A, Detailed Schematic Diagram	
4-4 Crystal Oscillator, Simplified Schematic Diagram			
4-5 200 Kc Oscillator and Reactance Tube, Simplified Schematic Diagram			
4-6 CW Oscillator and Mixer, Simplified Schematic Diagram			
4-7 FAX Isolator, Cathode Follower and Audio Amplifier, Simplified Schematic Diagram			

LIST OF TABLES

Table		Page	Table		Page
SECTION 1 — GENERAL INFORMATION			SECTION 5 — TROUBLESHOOTING		
1-1	Technical Characteristics	1-2	5-1	Troubleshooting Procedure	5-1
1-2	Tube and Semiconductor Complement	1-2			
SECTION 3 — OPERATOR'S SECTION			SECTION 6 — MAINTENANCE		
3-1	Operating Controls	3-2	6-1	Alignment Procedure	6-1



2025-1

Figure 1-1. Tone Intelligence Unit TIS-3A, Front Angle View

SECTION 1

GENERAL INFORMATION

1-1. GENERAL. (See figure 1-1.)

Tone Intelligence Unit TIS-3A (referred to as TIS) is an audio-shift keyer designed to be operated in conjunction with a synthesized or non-synthesized exciter. Its purpose is to generate a keyed or frequency-shifted audio tone output, so that the carrier generated by the exciter will not have to be keyed or shifted directly. Therefore, the frequency stability of the carrier is maintained.

One of the unique features of the TIS is that it does not use frequency multipliers to develop the frequency shift. A reactance-controlled oscillator is used to generate a center frequency, that is shifted in direct proportion with the applied grid voltage. In the FSK mode, the grid voltage is controlled by the SHIFT CPS control on the front panel, and the amount of shift is read directly on a counter-type knob. In the FAX mode, the grid voltage is regulated by the level of dc input signal and the SHIFT CPS control is bypassed. The audio tone output is developed by mixing the frequency-shifted output with a reference frequency generated by a second (crystal) oscillator. The difference frequency is amplified and applied directly to the exciter.

The TIS generates four discrete audio outputs as follows:

- a. 1000 cps for CW operation.
- b. An audio tone centered around 1900 cps for facsimile transmission.
- c. An audio tone centered around 2000 cps that may be used for either facsimile or FSK transmission.
- d. An audio tone centered around 2550 cps that is generally used for FSK transmission when the associated transmitter is operated in the ISB mode.

In addition, a spare crystal socket XY4, is provided for insertion of a crystal to produce any other audio tone desired. Utilizing this spare crystal socket with the CENTER FREQ CPS switch at SPARE position, the user may enhance the TIS capabilities. For example, a crystal producing a tone centered around 1000 cps may be used for either F1 (frequency shift keying) or F4 (facsimile) transmission. This method would make it possible to off-set a synthesized transmitter 1000 cps, thereby eliminating the need to retune the transmitter when switching from CW to FSK transmission.

The 1000 cps tone output available for the CW mode can only be keyed by means of an external

(battery-powered) hand key. The tones that are generated around 1900 cps, 2000 cps, 2550 cps and any additional tone that is selected for the fourth or spare position of the CENTER FREQ CPS switch may be used for either FSK or FAX mode.

1-2. FUNCTIONAL DESCRIPTION.

The TIS functionally consists of three oscillators (reactance-controlled, crystal and sidetone), a mixer and a push-pull audio amplifier.

The reactance-controlled oscillator generates a 200 kc output that is free from transients and shifted (in the FSK and FAX modes) in direct proportion with the applied grid voltage. The frequency shifted output is mixed with a reference frequency, generated by the crystal oscillator and selected to give the correct audio tone (difference) output. The difference frequency (shifted audio tone) is then applied by the push-pull amplifier to the exciter. In the FSK and FAX modes, B+ is not applied to the sidetone (CW) oscillator.

In the CW mode, B+ is removed from the reactance controlled oscillator and applied to the CW oscillator. Keying is then accomplished by routing the externally hand keyed pulses through a diode network, placing the space pulses at a zero reference level and the mark pulses at a negative level, irrespective of input characteristics.

The keying pulses are then amplified and cathode follower coupled to the cathode circuit of a push-pull audio amplifier stage. The CW oscillator output, a filtered 1000 cycle tone, is used to grid control the push-pull audio amplifier. This effectively causes the audio amplifier to conduct or key only on the negative or mark keying pulses. This keyed 1000 cycle tone is then made available at the output terminal board E3.

1-3. PHYSICAL DESCRIPTION.

Tone Intelligence Unit TIS-3A (figure 1-1) is mounted on a panel 19 inches wide and 5-1/4 inches high, for installation in a standard relay rack, and weighs approximately 54 lbs, when packed for shipment. The front panel is 3/16 of an inch thick and is finished in gray enamel.

The frame extends 14-5/16 inches behind the front panel, is self-supporting when the proper hardware is used, and contains a main chassis and a power supply chassis. The main chassis is mounted horizontally, and the power supply chassis is mounted

vertically on the right side of the frame facing the front panel.

All operating controls, fuses, and indicators are mounted on the front panel, and all tubes and adjustments are accessible from the top of the main chassis. The inputs and outputs are connected to a terminal block mounted on the rear of the main chassis

and the power jack is mounted at the rear of the power supply chassis.

1-4. REFERENCE DATA.

Table 1-1 lists the major electrical characteristics of the TIS. Table 1-2 lists the tubes and semiconductors used in the TIS and their function.

TABLE 1-1. TECHNICAL CHARACTERISTICS.

CW tone frequency:	1000 cps.
FAX input:	0 to +10 volts for a linear shift of 800 cps.
FSK output frequency shift:	12 to 1000 cps, continuously adjustable.
Crystal frequency stability:	1 part in 10 ⁶ per day.
Fuse protection:	1 ampere (115 volts). 0.5 ampere (230 volts).
Input compensating impedance to keying line:	KEY MODE control at 50V - 47,000 ohms KEY MODE control at 100V - 100,000 ohms KEY MODE control at 20MA - 2,200 ohms KEY MODE control at 60MA - 1,000 ohms
Keying input:	50v, 100v, 20ma, 60ma (all neutral, floating, or either side grounded).
Keying speed:	Up to 400 bauds for FSK, up to 150 bauds for CW; and up to 400 bauds for FAX.
Output audio center frequencies:	1900 cps, 2000 cps, 2550 cps, spare.
Output impedance:	600 ohms, balanced.
Output level:	Continuously adjustable to 0 dbm (0 to 1 milliwatt)
Oven temperature:	70° ±2°C.
Power input:	105/115/125/210/230 volts; 50-60 cps; single phase, 100 watts continuous, 170 watts intermittent.

TABLE 1-2. TUBE AND SEMICONDUCTOR COMPLEMENT.

REFERENCE DESIGNATION	TYPE	FUNCTION
V1	6J6 A	200-kc oscillator
V2	5963	Reactance tube
V3	12AU7A	2nd keyer
V4	12AU7A	1st keyer
V5	12AU7A	Mixer
V6	12AU7A	CW oscillator/FAX isolator
V7	12AU7A	Audio amplifier
V8	6AG5	Crystal oscillator
V9	OA2	Negative bias voltage regulator
V10	OA2	B+ voltage regulator
CR1, CR2	IN67	Gates
CR3 through CR6	IN547	Rectifier
CR7, CR8	IN67	Negative clipper
CR9	DD100	Full wave rectifier

SECTION 2 INSTALLATION

2-1. UNPACKING AND VISUAL INSPECTION.

The TIS has been tested and calibrated prior to shipment. Therefore, only minor adjustments are required before operating the unit.

Unpack the TIS carefully and inspect the packing material for parts which may have been shipped as loose items. Immediately after unpacking the TIS, perform the following visual inspection:

- (1) Inspect front panel and exterior of case for dents, scratches, cracked meter faces, and broken or missing controls.
- (2) Make certain fuses are installed in holders on front panel.
- (3) Remove top cover and inspect chassis for broken tubes and loose hardware. Make certain tubes are seated in sockets and replace cover.
- (4) Remove bottom cover; inspect for broken wires and loose hardware and replace cover.

Although the carrier is liable for any damage to the equipment, Technical Materiel Corporation will assist in describing and providing for repair of damaged items.

2-2. POWER REQUIREMENTS.

The power supply of the TIS has been designed for use with either 115 volt or 230 volt, 50/60 cycle, single-phase, three wire, 100 watt primary power. However, unless otherwise specified, the power supplies are wired at the factory for 115 vac, 50/60 cycle primary power, and minor wiring changes are required if 230 vac primary power is to be used.

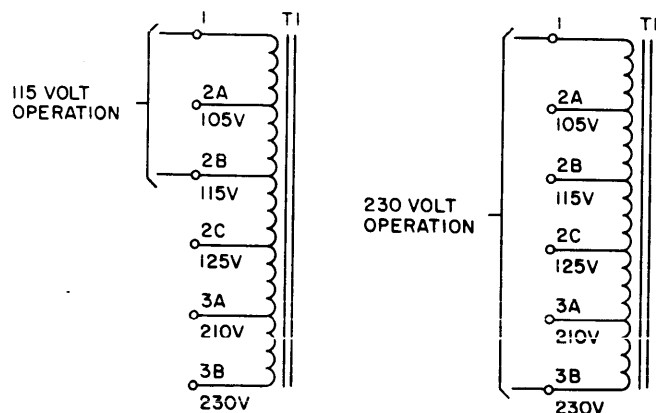

2025-2

Figure 2-1. Power Supply, Wiring Diagram

Figures 2-1 and 2-2 illustrate the wiring diagrams for 115 vac and 230 vac primary power.

2-3. INSTALLATION. (See figure 2-3.)

Mount the TIS in a standard 19 inch relay rack and secure with hardware provided. Connect inputs and outputs to pins of terminal block mounted on rear of main chassis (see figure 8-1) and connect power cord from jack at rear of power supply chassis to any convenient 115 vac receptacle. Turn B+/STANDBY switch to ON.

2-4. PRE-OPERATIONAL CHECKS.

The TIS is a highly stable instrument requiring an aging period of at least 24 hours of continuous operation. The equipment is designed for continuous operation and should only be deenergized for detailed repairs. Failure to comply with these stipulations will result in degradation of the stability.

After the initial aging period has elapsed, the OVEN indicator lamps should cycle continuously at regular intervals.

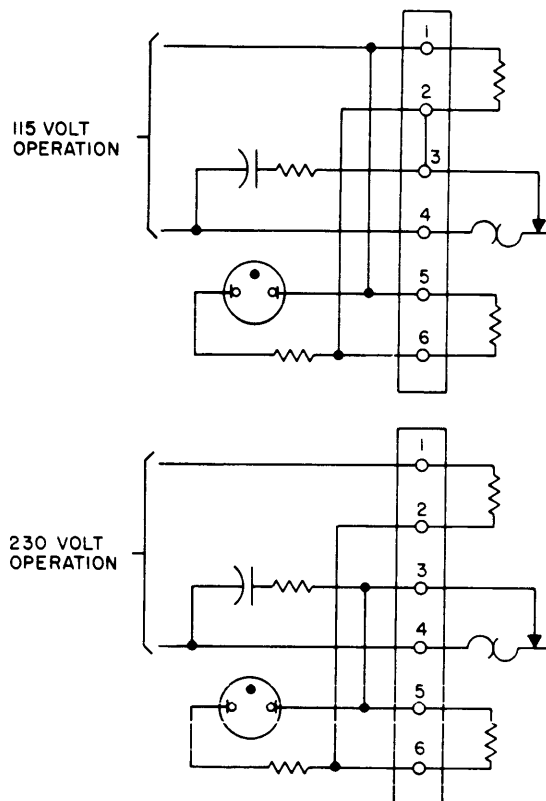

2025-3

Figure 2-2. Oven Wiring Diagram

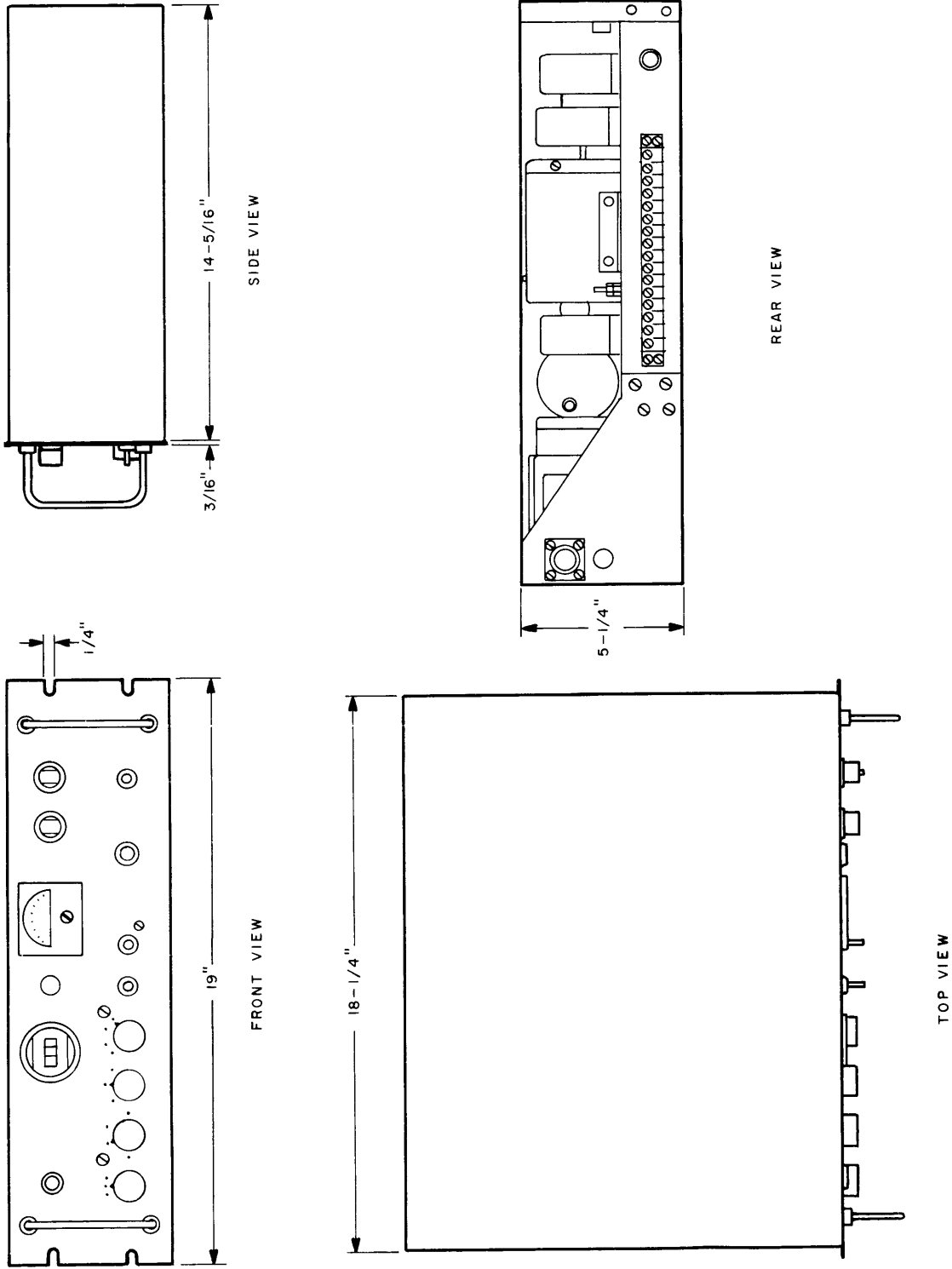

Figure 2-3. Tone Intelligence Unit TIS-3A, Installation Drawing

SECTION 3 OPERATORS SECTION

3-1. GENERAL .

For optimum stability, the TIS must be continuously energized and should be shut down only in the event of a failure. Therefore, an independent source of primary power must be provided so that the TIS can remain energized when the associated equipment is shut down.

3-2. OPERATING CONTROLS.

All the operating controls, fuses, and indicators are located on the front panel. Table 3-1 lists these operating controls and their function (see figure 3-1).

3-3. OPERATING PROCEDURES.

a. To operate the equipment in the FSK mode, proceed as follows:

- (1) Make certain OVEN indicator lamp is cycling at regular intervals.
- (2) Turn FUNCTION switch to FSK.
- (3) Turn TEST switch to LINE (normal position).
- (4) Turn KEY MODE switch to output level of external source providing input.

(5) Turn CENTER FREQ CPS switch to desired audio output frequency (normally 2550 cps).

(6) Turn EXCITER CH1 and EXCITER CH2 switches to appropriate mode.

(7) Apply FSK signal.

(8) Adjust LEVEL ADJ control for desired output (drive) level.

b. To operate the equipment in the FAX mode, proceed as follows:

(1) Make certain OVEN indicator lamp is cycling at regular intervals.

(2) Turn FUNCTION switch to FAX.

(3) Turn TEST switch to LINE.

(4) Turn CENTER FREQ CPS switch to desired audio output (normally 1900 cps).

(5) Turn EXCITER CH1 and EXCITER CH2 switches to appropriate mode.

(6) Adjust LEVEL ADJ control for desired output (drive) level.

(7) Apply FAX signal.

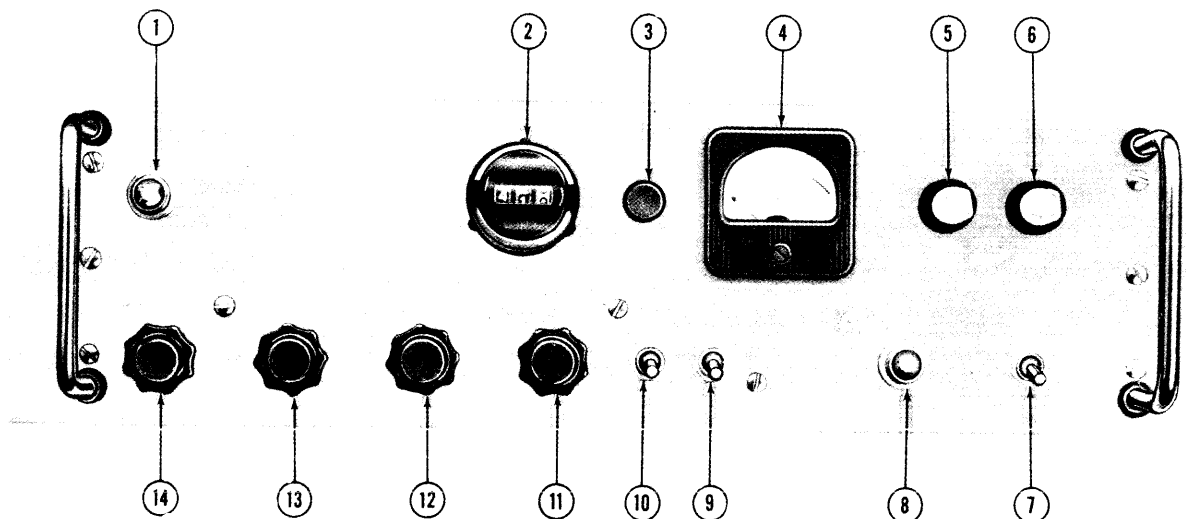

2025-5-1

Figure 3-1. Front Panel Operating Controls

TABLE 3-1. OPERATING CONTROLS

ITEM (See Fig. 3-1)	CONTROL OR INDICATOR	FUNCTION
1	OVEN indicator lamp I2	Indicates oven containing frequency determining components of reactance controlled oscillator is operating.
2	SHIFTS CPS control R31	In FSK mode, shifts audio tone output by amount indicated on readout.
3	LEVEL ADJ control R49	Adjusts level of output (drive) applied to load.
4	OUTPUT LEVEL meter M1	Indicates level of output in dbs.
5	MAIN fuse F1	Protects equipment from current overloads.
6	OVEN fuse F2	Protects oven from current overloads.
7	B+ /STANDBY switch S7	Applies B+ to all circuits.
8	B+ indicator lamp I1	Indicates B+ is applied to all stages.
9	EXCITER CH2 switch S5	Applies output to load.
10	EXCITER CH1 switch S4	Applies output to load.
11	KEY MODE switch S3	Matches input level of signal applied by external source to output level of crystal oscillator.
12	TEST switch S2	In FSK mode, provides a continuous mark or space for test purposes.
13	CENTER FREQ CPS switch S6	Selects center frequency of audio tone output.
14	FUNCTION switch S1	Selects mode of operation.

c. To operate the equipment in the CW mode, proceed as follows:

- (1) Make certain OVEN indicator lamp is cycling at regular intervals.
- (2) Turn FUNCTION switch to CW.
- (3) Turn TEST switch to LINE.
- (4) Turn KEY MODE switch to level of input signal.
- (5) Turn EXCITER CH1 and EXCITER CH2 switches to appropriate modes.

(6) Operate handkey.

NOTE

When selecting a crystal to be used in the SPARE crystal socket XY4, use the formula:

$$f_x = 200 \text{ KC} - f_o$$

f_x = desired crystal frequency

200 KC = TIS reference frequency

f_o = desired tone frequency

SECTION 4

PRINCIPLES OF OPERATION

4-1. OVERALL BLOCK DIAGRAM ANALYSIS.

Figure 4-1 is an overall block diagram of the TIS. The FSK and CW inputs are applied across the selected contacts of KEY MODE switch S3 to the center taps of transformers T3 and T4 and combined with the reference frequency output of crystal oscillator V8. The combined (r-f) pulses are then applied to a full wave rectifier bridge (CR9) and applied to the grid of first keyer V4B, operating as a dc amplifier.

The output of the first keyer is applied across TEST switch S2 to the grid of second keyer V3A, also operating as a dc amplifier. During normal operation, the TEST switch is kept in the LINE position. The MARK position applies a constant voltage to the grid of the second keyer to simulate a continuous mark for test purposes, and the SPACE position grounds the grid of the second keyer to simulate a continuous space for test purposes. The amplified pulse output of the second keyer is applied to the FSK or CW contacts of FUNCTION switch S1.

The FAX input is applied across FAX ADJ control R66, FAX isolator V6B and FAX BIAS ADJ control R44 to the FAX contacts of the FUNCTION switch. The FAX ADJ control sets the threshold bias of the FAX isolator, operating as a cathode follower, and the FAX BIAS ADJ control adjusts the output level of the FAX isolator, applied to the grid of reactance control V2 across the FAX contacts of the FUNCTION switch.

In the FSK mode, B+ is removed from CW oscillator V6A by the FUNCTION switch, and the amplified output of the second keyer is applied across SHIFT CPS control R31 to the grid of the reactance control. Oscillator V1 generates a stable 200 kc frequency that is offset by an amount inversely proportional to the amplitude and polarity of the grid voltage applied to the reactance control. The offset frequency output of oscillator V1 is heterodyned in mixer V5 with the reference frequency from the crystal oscillator, and the difference frequency (2 kc \pm frequency shift) applied to the grids of audio amplifier V7 across transformer T2.

In the FAX mode, B+ is still removed from the crystal oscillator and the adjusted output of the FAX isolator is applied across the FAX contacts of the FUNCTION switch to the grid of the reactance control. The SHIFTS CPS control is completely bypassed and the output frequency of oscillator V1 is offset by an amount inversely proportional to the amplitude and polarity of the input pulses. The offset frequency output of oscillator V1 is then mixed

with the reference frequency from the crystal oscillator, and the difference frequency applied to the grids of the audio amplifier.

In the CW mode, B+ is applied to the CW oscillator by the FUNCTION switch, and B+ is removed from oscillator V1. The audio tone output (1000 cycles) of the CW oscillator is applied to the grids of the audio amplifier across transformer T2, and at the same time, the amplified pulses from the second keyer applied to the cathode gate the push-pull output of the audio amplifier is synchronization with the input pulses from the external handkey.

Regardless of the mode selected, the push-pull output of the audio amplifier is applied across the two channel switches in parallel (when turned to FSK, FAX, CW) and monitored continuously on the OUTPUT LEVEL meter.

4-2. INPUT CIRCUIT AND FIRST KEYER.

Figure 4-2 is a simplified schematic of KEY MODE switch S3, balanced transformers T3 and T4, bridge rectifier CR9 and first keyer V4B.

The CW or FSK input pulses are applied across pins 13 and 14 of terminal block E3, mounted on the rear of the main chassis, to the wiper of the KEY MODE switch and the center tap of transformer T3. The resistors connected to the contacts of the KEY MODE switch match the level of the input pulses with the output level of crystal oscillator V8 at the secondary of transformer T4. For a large positive input (mark) pulse, diodes CR1 and CR2 conduct and the combined signal is applied across transformer T3 to bridge rectifier CR9. For a negative input (space) pulse, diodes CR1 and CR2 do not conduct, and there is no output across transformer T3.

The 50V and 100V contacts of the KEY MODE switch are used to match the output level of a conventional handkey, and the 20MA and 60MA contacts match the output level of conventional teletypewriter equipment. The rectified pulses from the bridge rectifier are amplified and inverted by the first keyer and applied to the grid of second keyer V3A across TEST switch S2 (see figure 4-3).

4-3. SECOND KEYER AND TEST SWITCH.

Figure 4-3 is a simplified schematic of TEST switch S2, second keyer V3A and FUNCTION switch S1.

The dc pulses from first keyer V4B are applied across the TEST switch to the grid of second keyer V3A. The TEST switch is normally kept in the LINE position, and the output of first keyer V4B is coupled directly to the grid of the second keyer. In the MARK position, a continuous voltage is applied to the grid of the second keyer to simulate a continuous MARK pulse for test purposes. In the SPACE position, the grid of the second keyer is grounded to simulate a continuous SPACE pulse.

The second keyer amplifies and inverts the dc pulses and its output is coupled by cathode follower V3B to the FUNCTION switch and cathode follower V4A.

In the FSK mode, the output of cathode follower V3B is applied across SHIFT BALANCE control R26, SHIFT CALIBRATE control R28, SHIFT CPS control R31, and the FUNCTION switch to the grid of reactance control V2. The SHIFT BALANCE control sets the zero point for the frequency shift, which may be positive or negative. The SHIFT CALIBRATE control sets the SHIFT CPS counter at zero when there is no signal applied to the grid of the second keyer. The SHIFT CPS control sets the grid voltage of reactance control V2, during the FSK mode only, and shifts the output frequency of oscillator V1 by the amount indicated on the SHIFT CPS counter.

In the FAX mode, the TEST switch is turned to LINE and the output of the second keyer is coupled by cathode follower V3B directly across the FUNCTION switch (see dotted line) to the grid of reactance control V2. Note that the SHIFT BALANCE control, SHIFT CALIBRATE control, and SHIFT CPS control are completely bypassed.

In the CW mode, the TEST switch is turned to LINE, and the output of the second keyer is coupled by cathode follower V3B, across the SHIFT BALANCE control and THRESHOLD ADJUSTMENT control R27 to the FUNCTION switch. The THRESHOLD ADJUSTMENT control applies a position of the signal to cathode follower V4A, for coupling to the grid of mixer V5.

4-4. CRYSTAL OSCILLATOR.

Figure 4-4 is a simplified schematic of crystal oscillator V8, temperature controlled ovens Z1 and Z2, and CENTER FREQUENCY switch S6.

The crystal oscillator operates as an electron-coupled oscillator with the resonant frequency selected from four plug-in crystals. A crystal selected by the CENTER FREQUENCY switch is applied to crystal oscillator V8, which is coupled by a broad band tuned tank (L6) to the grids of mixer V5 and the primary of transformer T4.

Each crystal is enclosed in a temperature controlled oven for optimum stability and is provided with individual trimmer capacitors to insure correct frequency output. The resonant frequency of each crystal is selected so that when the output of the crystal oscillator is heterodyned with the frequency

shifted output of oscillator V1, the desired audio tone center frequency output selected at the front panel will be developed.

4-5. REACTANCE CONTROLLED OSCILLATOR.

Figure 4-5 is a simplified schematic of oscillator V1 and reactance control V2.

Oscillator V1 is a modified push-pull Colpitts oscillator, generating a 200 kc sine wave output. The major components of the resonant tank circuits are enclosed in a temperature controlled oven with a fast heating characteristic and have extremely uniform retrace characteristics. Trimmer C3 is the coarse adjust control, and trimmer C46 is the fine adjust control. Both these controls are located on the top of the main chassis.

The input signal is applied across the FUNCTION switch to the grids of reactance control V2, and the offset frequency output used to vary the reactive components of the oscillator tank by an amount directly proportional to the applied input. REACTANCE TUBE LINEARITY ADJUSTMENT control C18 sets the reference point for the input voltage so that the frequency will be offset linearly in each direction. The offset frequency output of oscillator V1 is then applied to the grid of mixer V5 (see figure 4-6).

4-6. CW OSCILLATOR AND MIXER.

Figure 4-6 is a schematic diagram of CW oscillator V6A and mixer V5.

In the FAX or FSK mode, the offset frequency output of oscillator V1 (200 kc \pm frequency shift) is combined with the reference frequency output of crystal oscillator V8 (198.000 kc + 100 kc, - 500 kc) on the grids of mixer V5, and the difference frequency output (2 kc \pm frequency shift) applied across the balanced primary windings of transformer T2 to LEVEL ADJ control R49. The LEVEL ADJ control sets the level of the outputs applied to the load by adjusting the amplitude of the voltage applied to the grids of audio amplifier V7.

MIXER BALANCE ADJUSTMENT control R67 is set for equal condition through both sections of mixer V5.

In the CW mode, 150 volts B+ is removed from the reactance controlled oscillator V1 and applied to the CW oscillator V6A. Keying is then accomplished by interrupting or keying the crystal oscillator V8 output across transformers T3, T4 and diodes CR1 and CR2. The output of T3 is applied through a diode bridge rectifier network CR9 producing a series of square waves or pulses, keyed at a zero reference level. This method of keying will produce a zero referenced signal, irrespective of input characteristics.

The keying pulses, the space at a zero reference level and mark at a negative level, are applied to first keyer V4B where it is amplified and routed, through TEST switch S2, to the input of second keyer

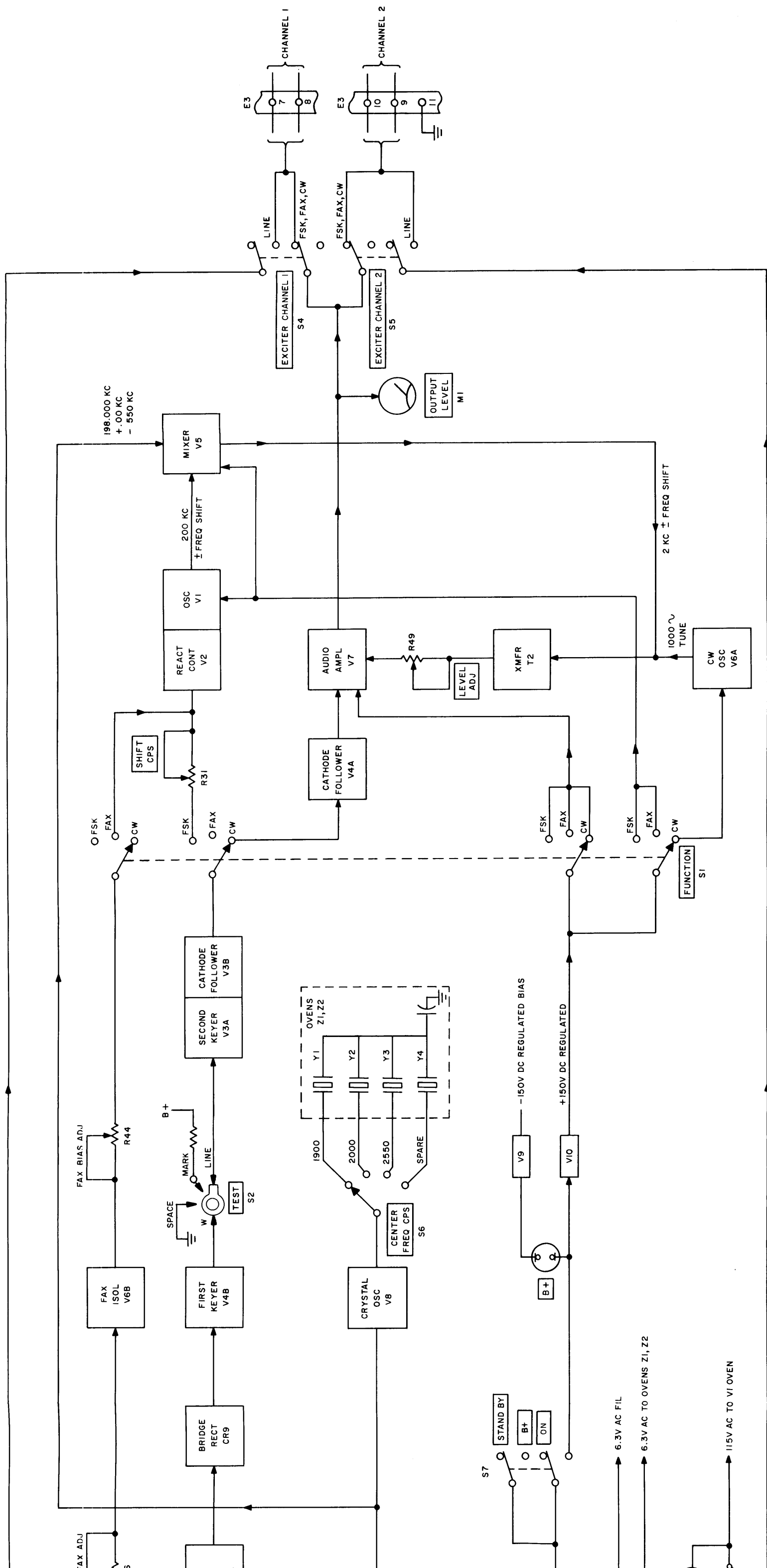
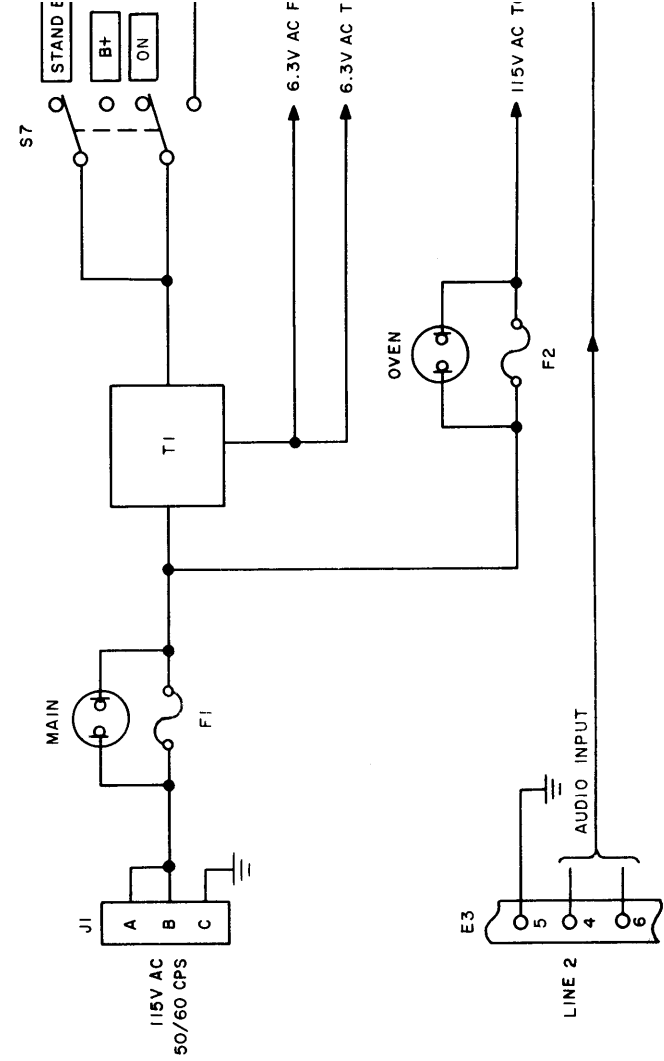
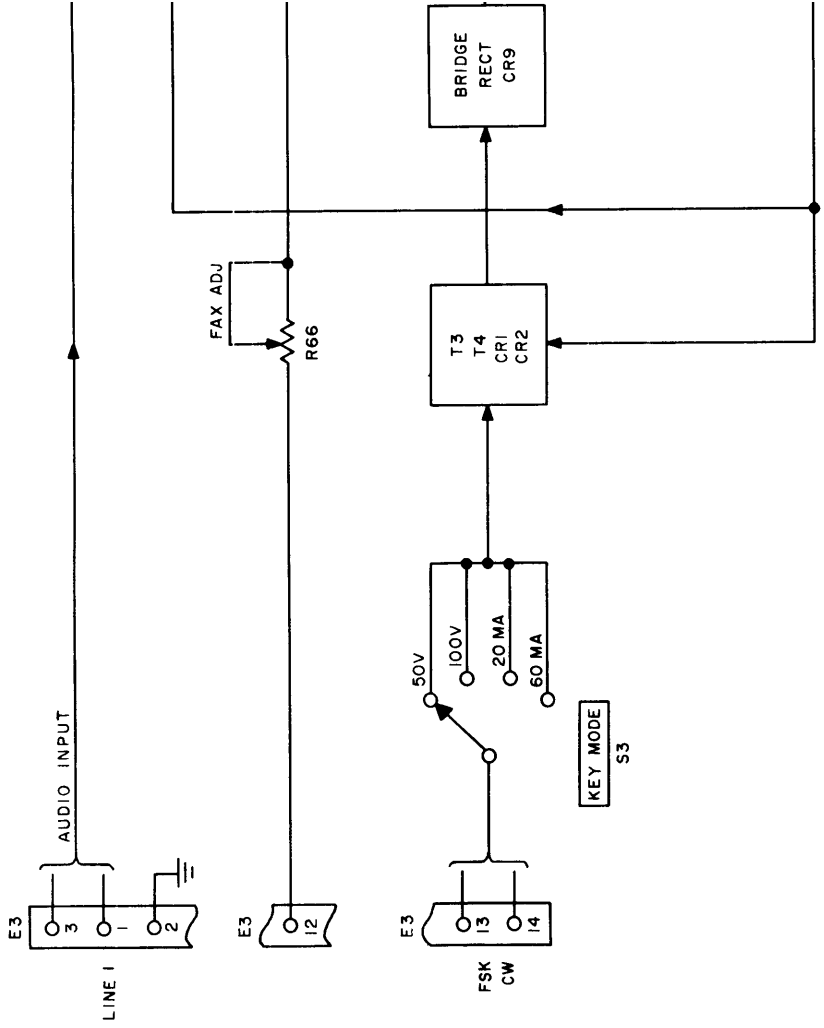
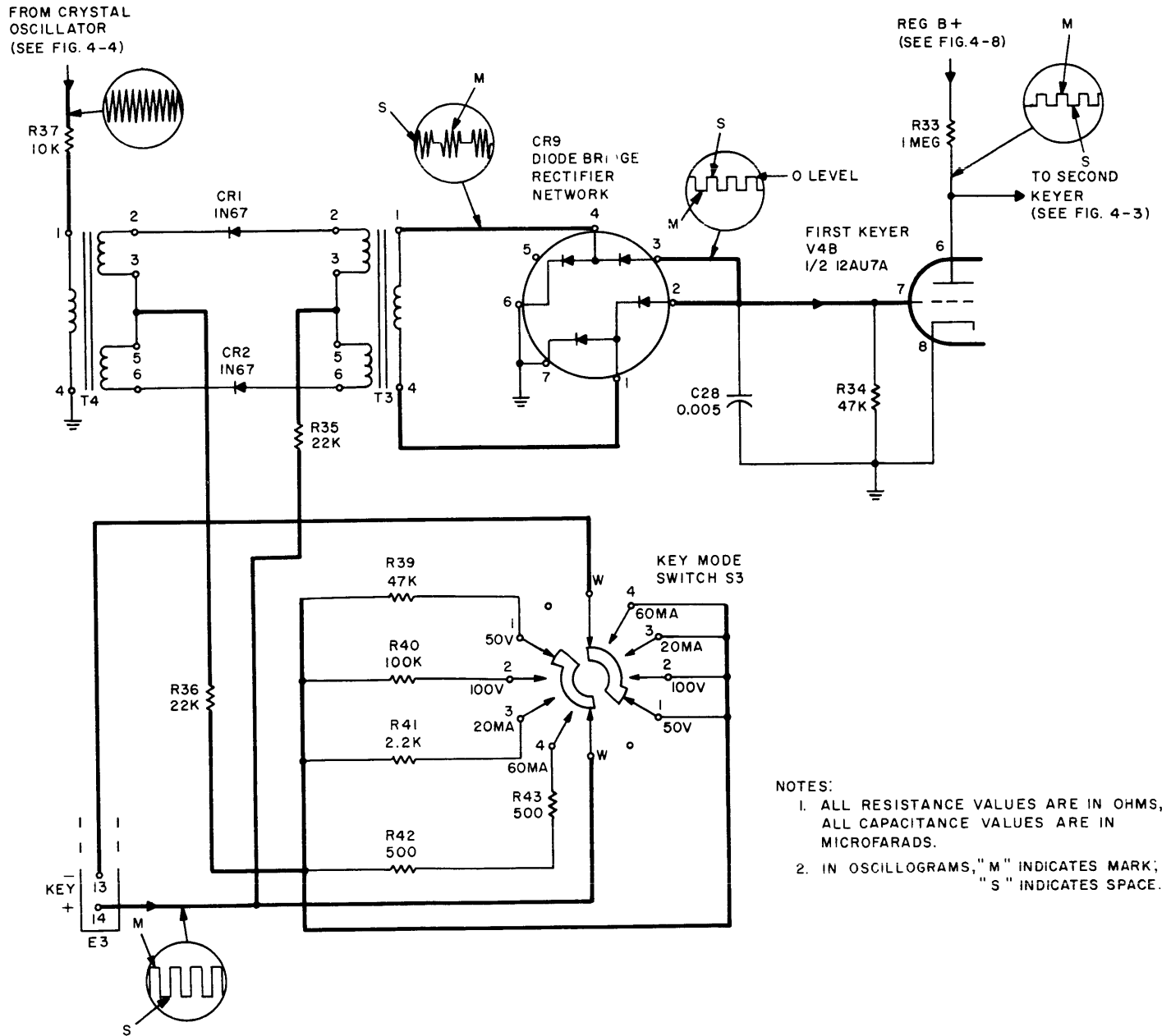

Figure 4-1. Tone Intelligence Unit TIS-3A, Overall Block Diagram



2025-6

001652025



2025-7

Figure 4-2. First Keyer, Simplified Schematic Diagram

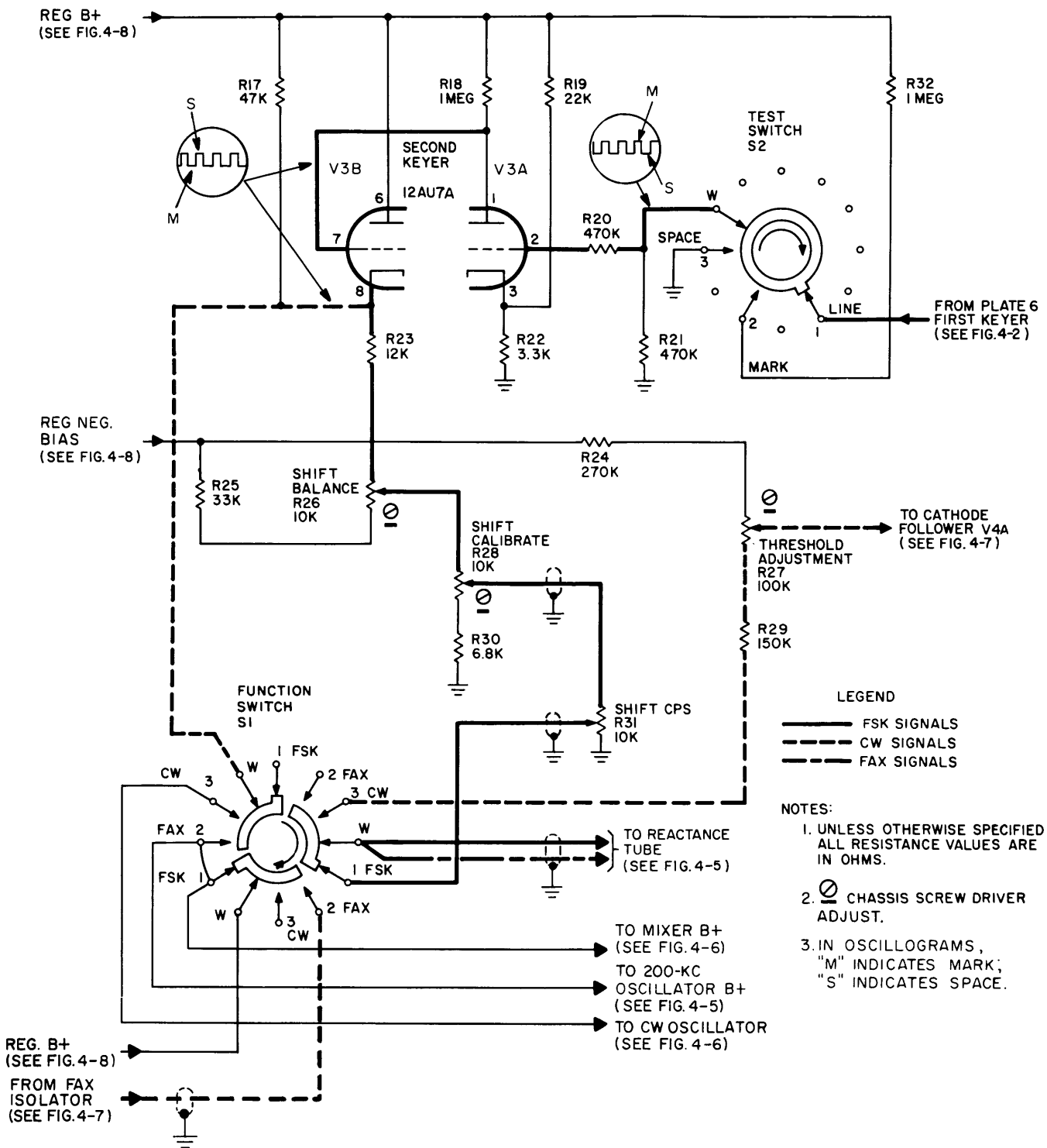

2025-8

Figure 4-3. Second Keyer, Simplified Schematic Diagram

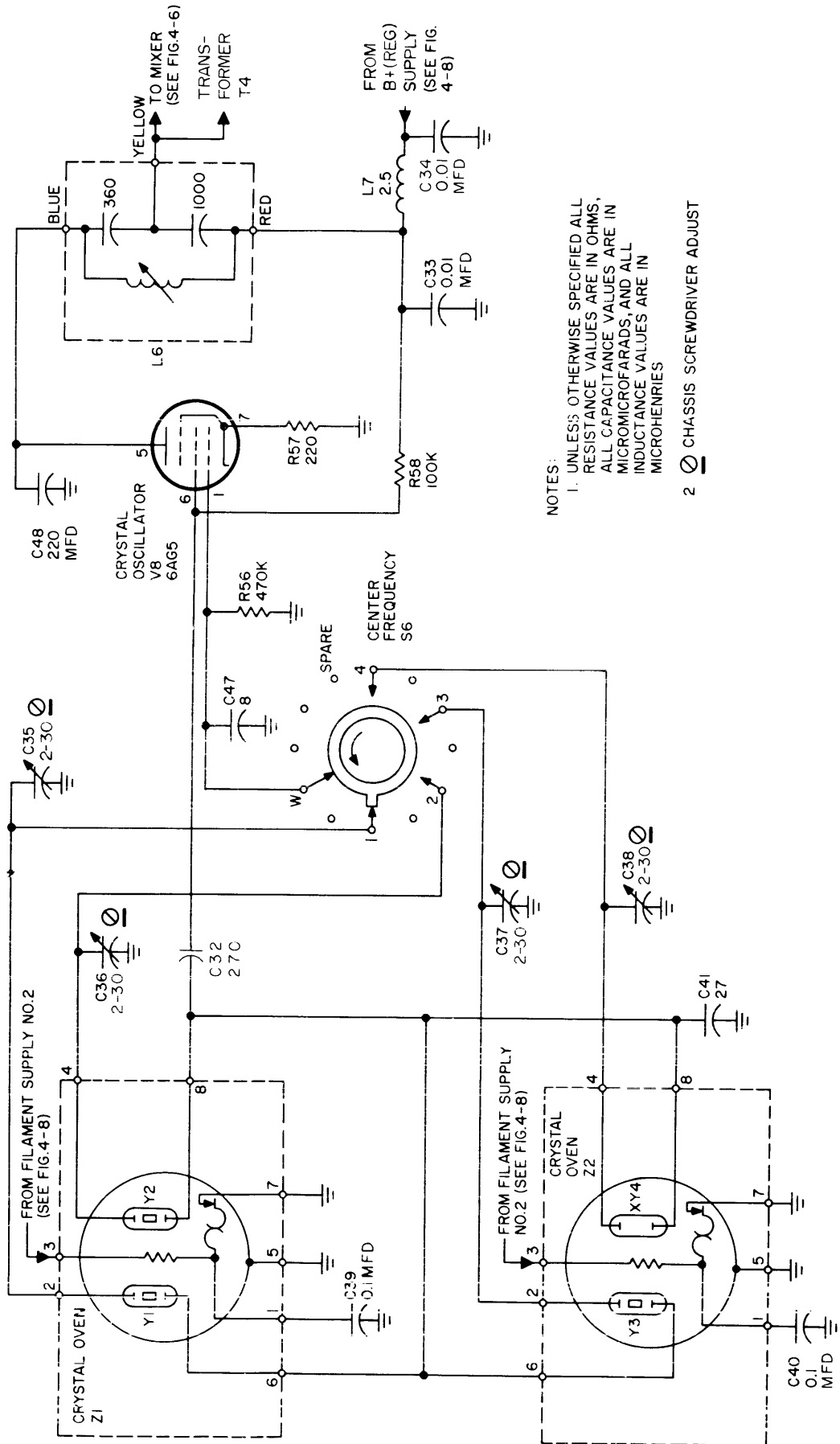

NOTES:
 1. UNLESS OTHERWISE SPECIFIED ALL RESISTANCE VALUES ARE IN OHMS, ALL CAPACITANCE VALUES ARE IN MICROMICROFARADS, AND ALL INDUCTANCE VALUES ARE IN MICROHENRIES
 2. CHASSIS SCREWDRIVER ADJUST

Figure 4-4. Crystal Oscillator, Simplified Schematic Diagram

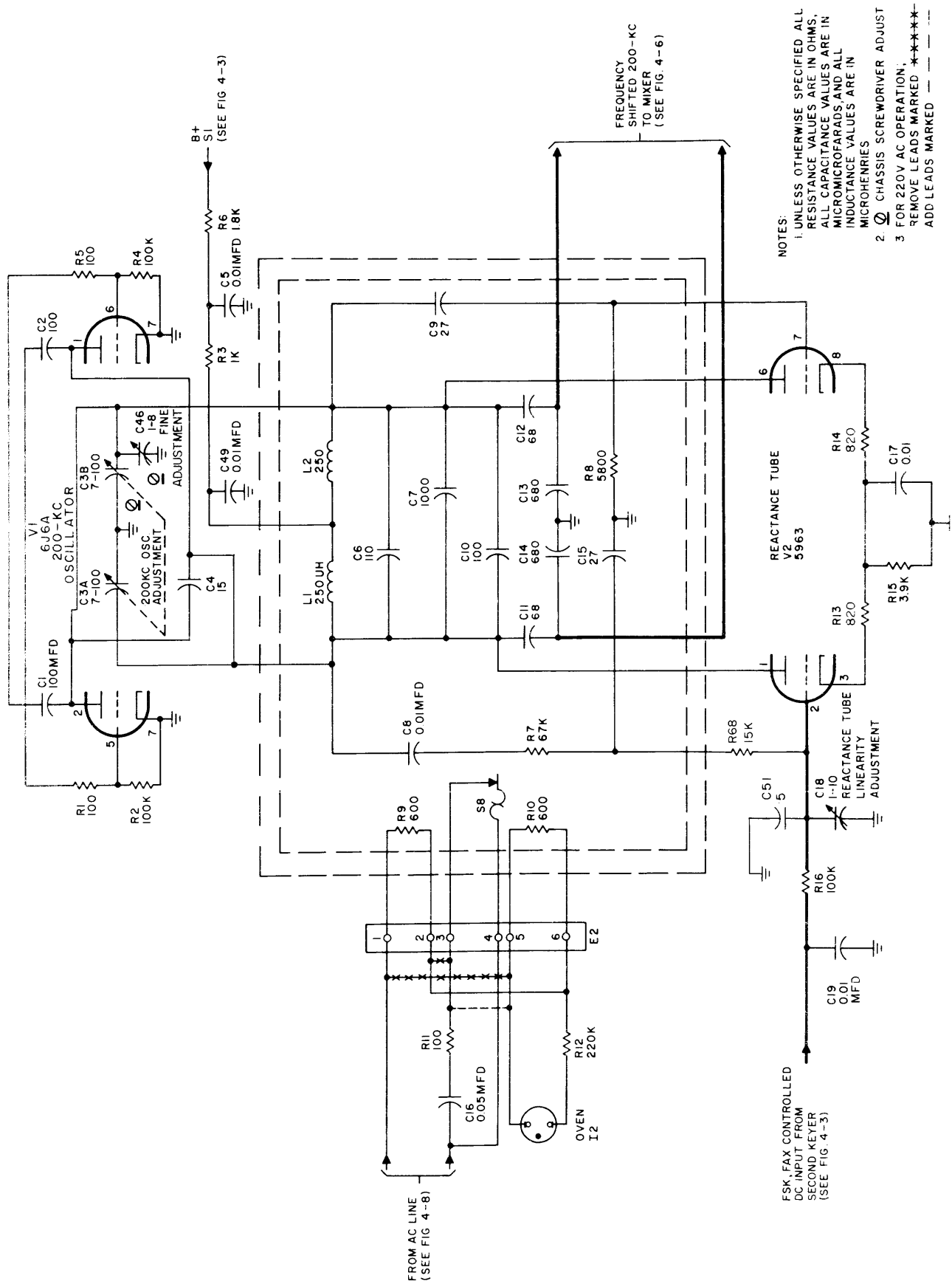
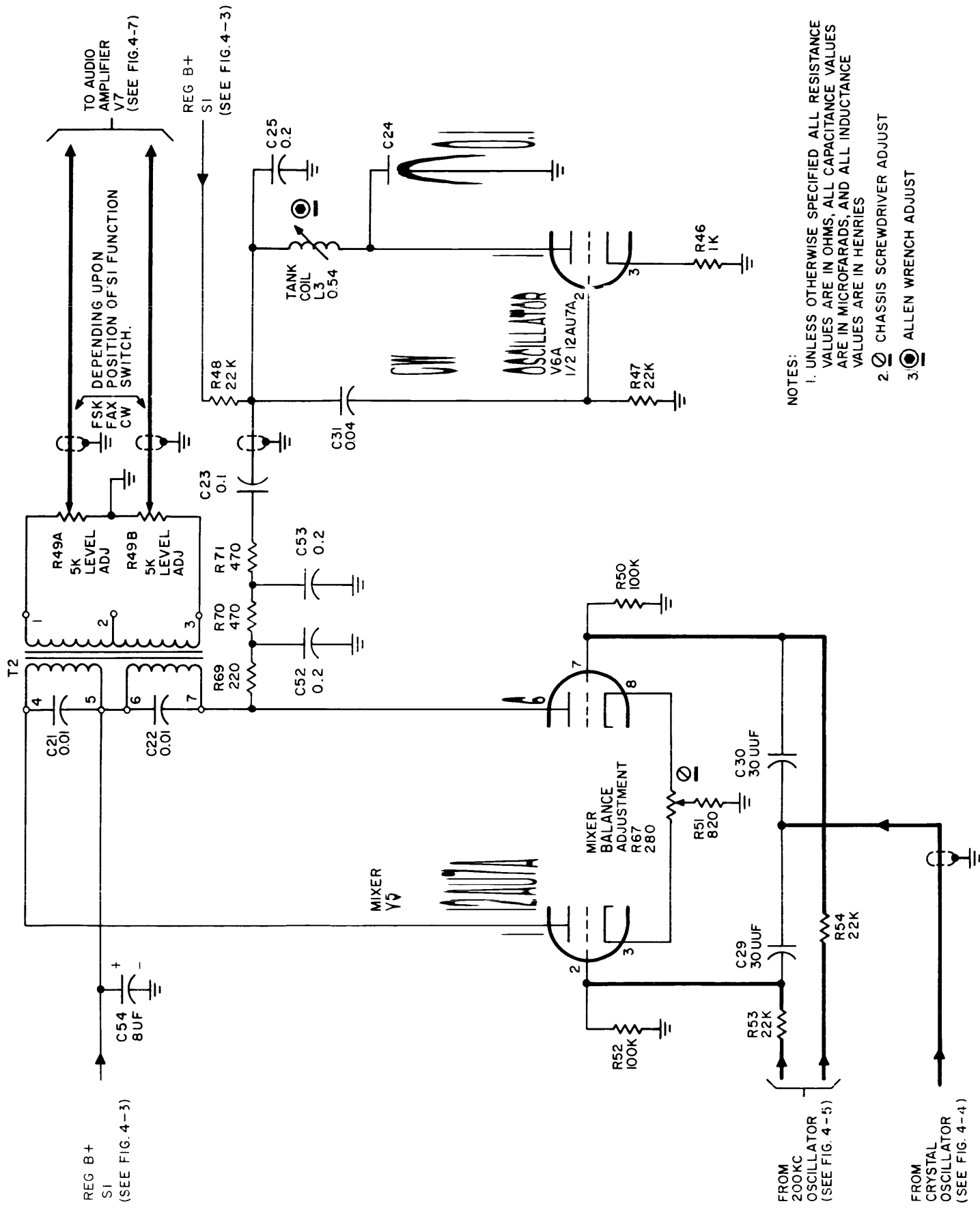

Figure 4-5. 200 Kc Oscillator and Reactance Tube, Simplified Schematic Diagram



- NOTES:
1. UNLESS OTHERWISE SPECIFIED ALL RESISTANCE VALUES ARE IN OHMS, ALL CAPACITANCE VALUES ARE IN MICROFARADS, AND ALL INDUCTANCE VALUES ARE IN HENRIES
 2. Ⓞ CHASSIS SCREWDRIVER ADJUST
 3. Ⓢ ALLEN WRENCH ADJUST

Figure 4-6. CW Oscillator and Mixer, Simplified Schematic Diagram

V3A. The amplified output is then applied to the second portion of second keyer V3B, cathode follower coupled, through FUNCTION switch S1 to the input of the first section of first keyer V4A. This output, with the space still at a zero reference level and mark at a negative level, is then cathode follower coupled to the cathode circuit of a push-pull audio amplifier stage V7, through AUDIO BAL control R64.

The crystal oscillator V8 output is also applied to the grids of mixer V5, operating as a conventional amplifier. The amplified crystal oscillator output is then superimposed with a filtered 1 kc tone generated by CW oscillator V6A. Due to the low band-pass region of transformer T2, only the 1 kc tone is passed and applied to the control grids of audio amplifier V7.

With the 1 kc tone at the control grids, only the negative mark pulses will cause conduction or keying of the audio amplifier. This keyed output is then transformer T5 coupled to the output terminal board E3.

Spurious emissions from the 1 kc CW oscillator V6A are suppressed by a filter network comprised of R69, R70, R71, C52 and C53.

4-7. FAX ISOLATOR AND AUDIO AMPLIFIER.

Figure 4-7 is a simplified schematic of FAX isolator V6A, cathode follower V4A, and audio amplifier V7.

In the FAX mode, the input pulses are applied across pins 5 and 12 of barrier strip E3, mounted on the rear of the main chassis, and FAX ADJ control R66 to the grid of FAX isolator V6B, operating as a cathode follower. The output of FAX isolator V6B is applied across FAX BIAS ADJUSTMENT control R44 to the grid of reactance control V2 across the FUNCTION switch.

In the FSK and FAX modes, the frequency shifted output of transformer T2 is applied to the grids of audio amplifier V7. The push-pull output of audio amplifier V7 is then applied across transformer T5 to OUTPUT LEVEL meter M1 and EXCITER CH1 switch S4 and EXCITER CH2 switch S5 in parallel.

In the CW mode, the amplified 1000 cycle tone output of transformer T2 is applied to the grids of audio amplifier V7 and B+ is removed from oscillator V1. The amplified CW output pulses from second keyer V3A are coupled across THRESHOLD ADJUSTMENT control R27 and cathode follower V4A to the cathode of audio amplifier V7 across AUDIO BALANCE control R64.

As a result of applying the gated input pulses to the cathode of audio amplifier V7, the push-pull output applied to transformer T5 is gated on and off in synchronization with the input pulses. AUDIO BALANCE control R64 is factory set for equal conduction through both halves of audio amplifier V7.

4-8. POWER SUPPLY.

Figure 4-8 is a simplified schematic of the power supply chassis.

The 115 vac input is applied across fuses F1 and F2 to the primary of power transformers T1 and the heater element of the oven containing the frequency determining elements of oscillator V1.

The secondary of transformer T1 has two filament voltage (6.3 vac) windings and the main winding, connected to the contacts of B+/STANDBY switch S7. One filament winding supplies power to the filaments of the tubes, and the other winding provides power to the heating elements of ovens Z1 and Z2.

When the B+/STANDBY switch is turned ON, approximately 350 vac is applied across a full wave bridge rectifier, consisting of diodes CR3, CR4, CR5, and CR6, and B+ indicator lamp I1 lights.

The -150 volts regulated bias voltage supplied to CW oscillator V6A and cathode followers V3B and V4A is developed from the voltage tapped off the junction of diodes CR4 and CR6 and regulated by voltage regulator V9.

The unregulated 150 volts B+ supply voltage is developed from the voltage tapped off the junction of diodes CR3 and CR5 and applied directly to the stages across a capacitor input filter. The regulated 150 volts B+ is developed from the voltage tapped off the junction of diodes CR3 and CR5 and regulated by voltage regulator V10.

SIGNAL FLOW SHOWN FOR V7 IS CW.
ON FSK OR FAX, SIGNAL FLOWS IS INTO
GRIDS 2,7 ONLY AND OUT OF PLATES 1,6

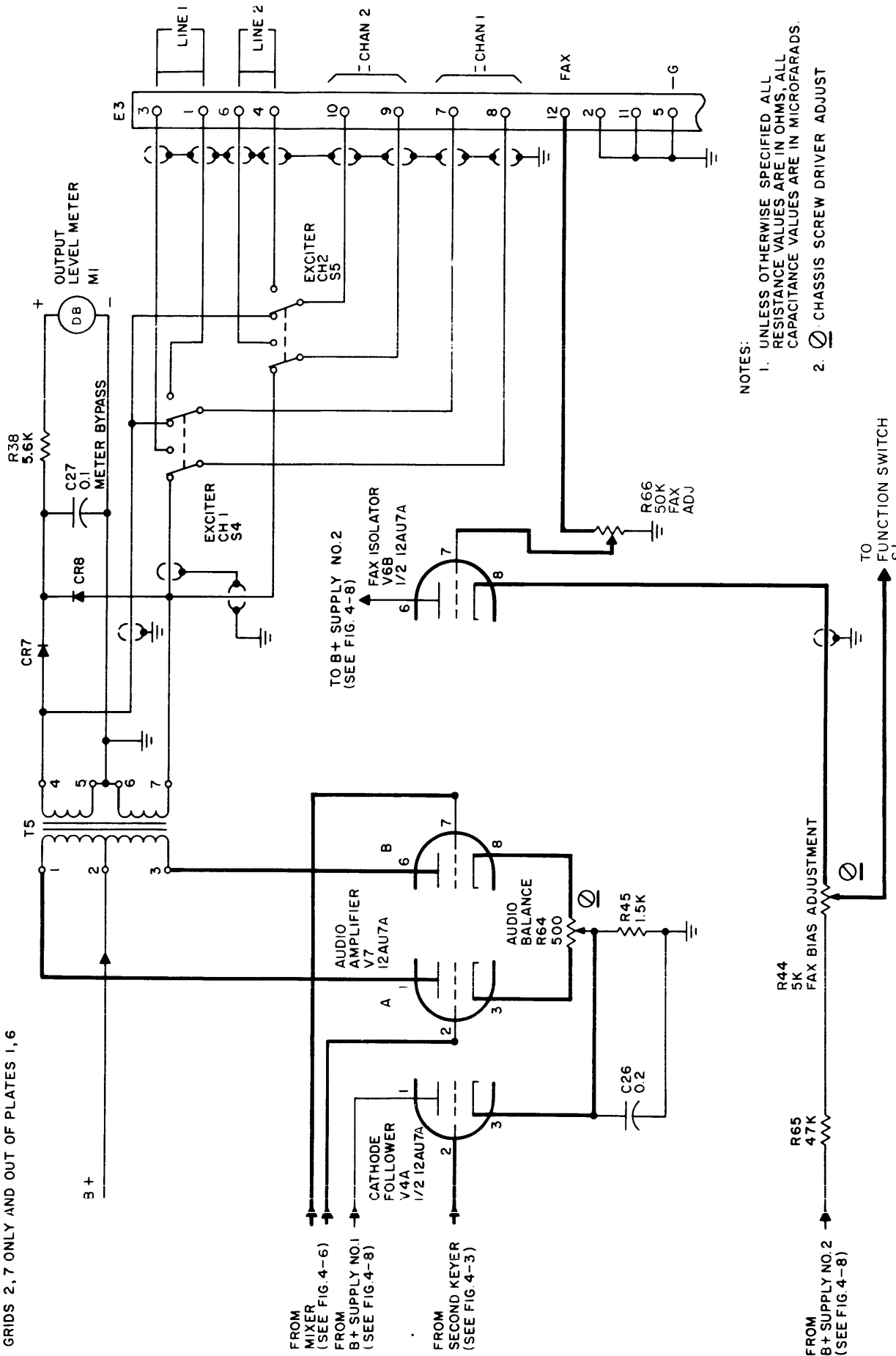

- NOTES:
1. UNLESS OTHERWISE SPECIFIED ALL RESISTANCE VALUES ARE IN OHMS, ALL CAPACITANCE VALUES ARE IN MICROFARADS.
 2. CHASSIS SCREW DRIVER ADJUST

Figure 4-7. FAX Isolator, Cathode Follower and Audio Amplifier, Simplified Schematic Diagram

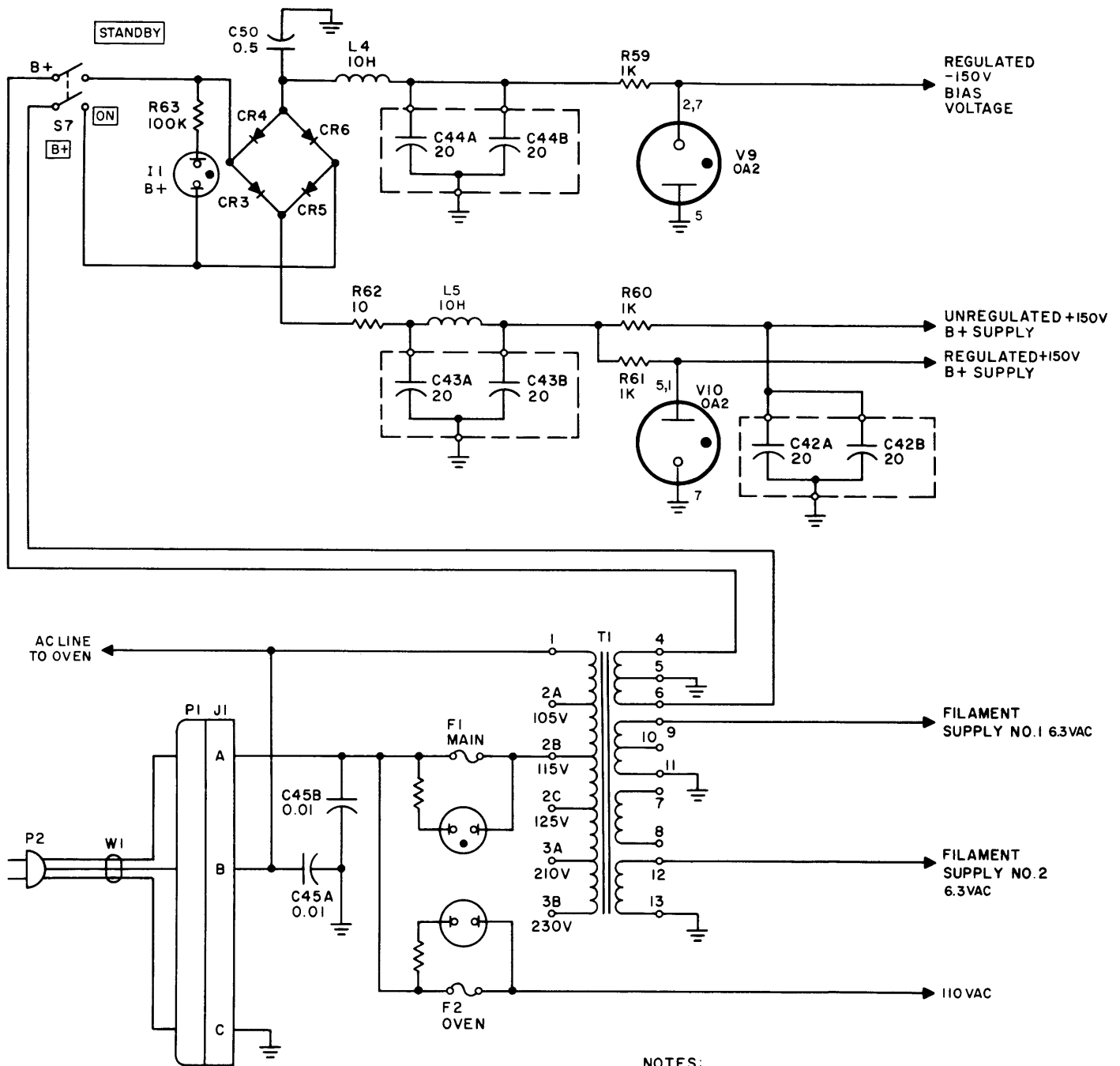

NOTES:
 1. UNLESS OTHERWISE SPECIFIED ALL RESISTANCE VALUES ARE IN OHMS, ALL CAPACITANCE VALUES ARE IN MICROFARADS, AND ALL INDUCTANCE VALUES ARE IN HENRIES.

Figure 4-8. Power Supply, Simplified Schematic Diagram

SECTION 5 TROUBLESHOOTING

5-1. GENERAL.

When a piece of equipment that has been operating satisfactorily suddenly fails, the cause of trouble may be apparent or the symptoms analogous to past failures. If the cause of failure is apparent, a lengthy troubleshooting procedure is not required. Therefore, make certain primary power and an input signal is applied before beginning a lengthy procedure to locate the trouble. In addition, check the fuses and tubes and inspect the underside of the chassis for burned or ruptured components, broken wires and frayed insulation.

Table 5-1 lists a troubleshooting procedure designed to isolate the cause of failure when all conditions seem normal, but the equipment fails to operate (see figure 8-1). Refer to Section 6 of this manual for corrective maintenance procedures after the cause of trouble has been isolated.

Refer to figure 5-1 for the normal voltage and resistance measurements at the pins of each tube socket. Figures 5-2 through 5-7 illustrate the location of all major components.

TABLE 5-1. TROUBLESHOOTING PROCEDURE

SYMPTOM	PROCEDURE
<p>OVEN indicator lamp does not cycle.</p>	<p>a. Check indicator lamp 12. b. Check 110 vac across pins 1 and 4 of terminal strip E2.</p>
<p>In CW mode, OUTPUT LEVEL meter indicates constant level.</p>	<p>a. Make certain TEST switch is turned to LINE. b. Turn KEY MODE switch to 50 V and apply +50 vdc input across pins 13 and 14 of terminal strip E3. c. Check input voltage on grid of cathode follower V4A. d. Check grid voltage of second keyer. e. Check voltages across secondaries of transformers T3 and T4. f. Remove +50 vdc from pins 13 and 14 of terminal strip E3.</p>
<p>In CW mode, OUTPUT LEVEL meter indicates low level and deflects slightly when handkey is closed.</p>	<p>a. Make certain TEST switch is turned to LINE. b. Check B+ voltage on CW oscillator. c. Check grid voltage of audio amplifier. d. Check push-pull output of audio amplifier.</p>
<p>In FAX mode, OUTPUT LEVEL meter indicates a constant reading.</p>	<p>a. Apply +10 vdc input to pin 12 of terminal strip E3. b. Check grid voltage of reactance control tube. c. Check output level of FAX isolator. d. Remove +10 vdc input.</p>
<p>In FAX mode, OUTPUT LEVEL meter indicates zero.</p>	<p>a. Check -150 vdc bias applied to pin 6 of socket XV1. b. Apply +10 vdc input to pin 12 of terminal strip E3.</p>

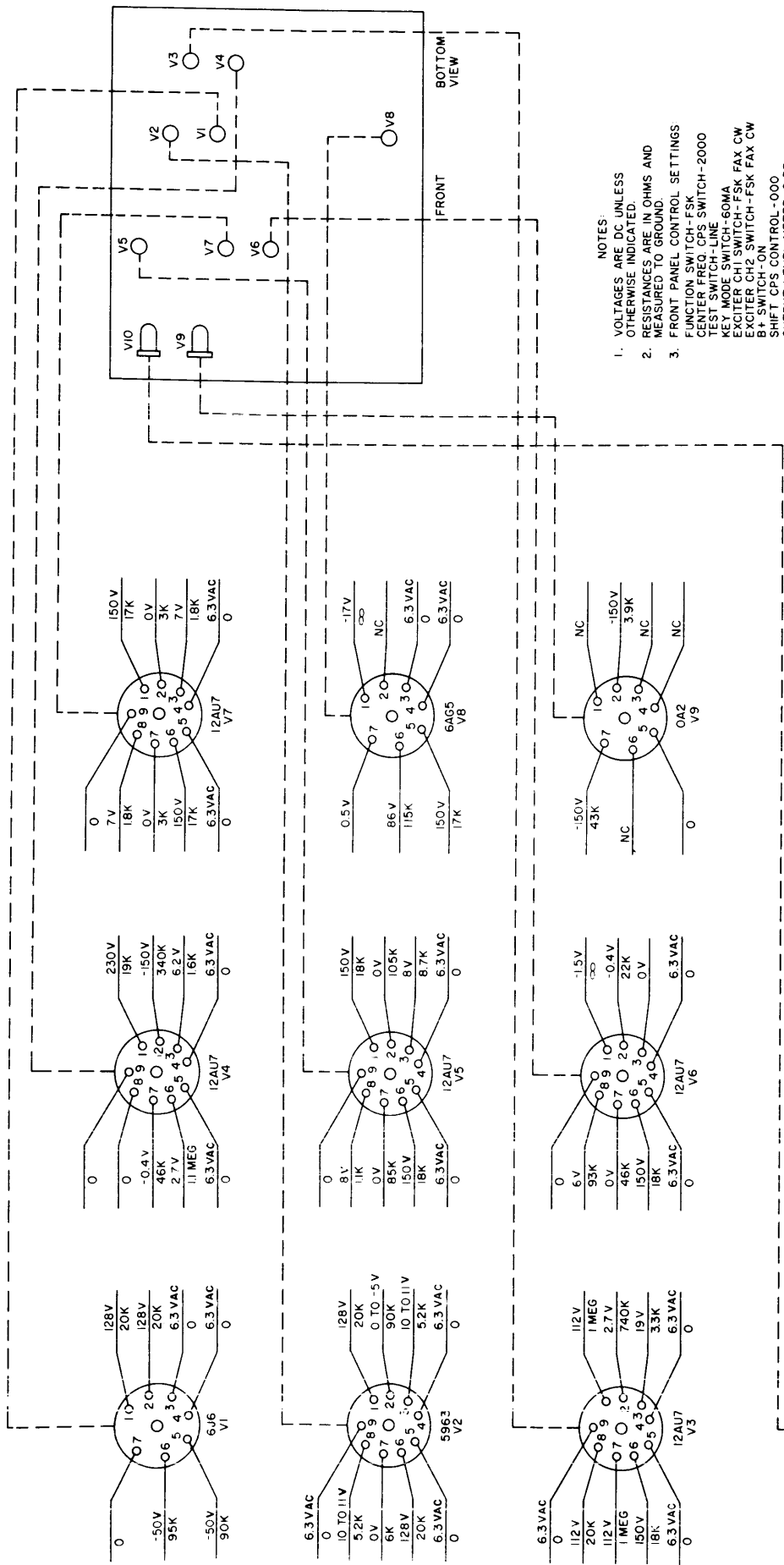
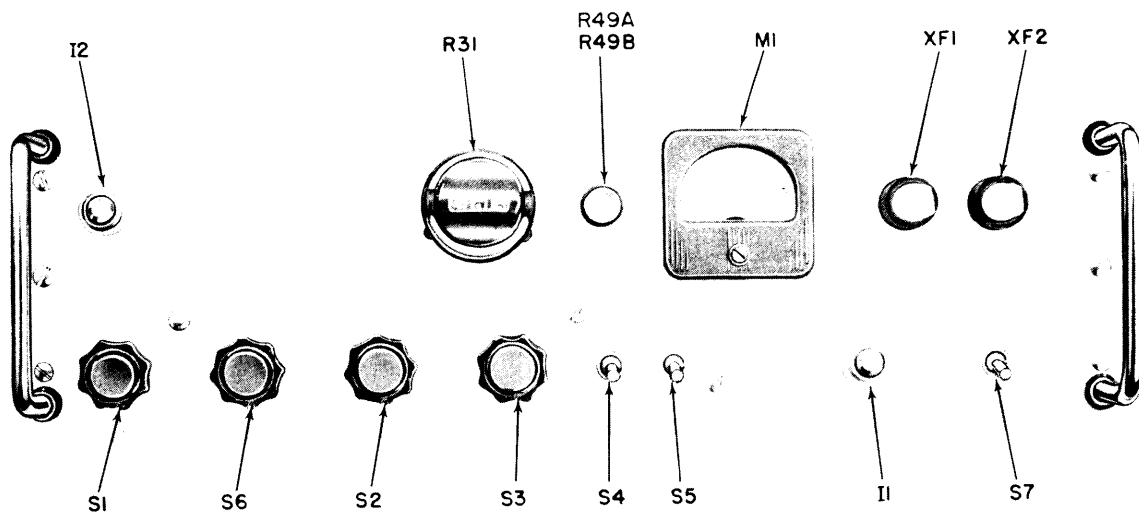
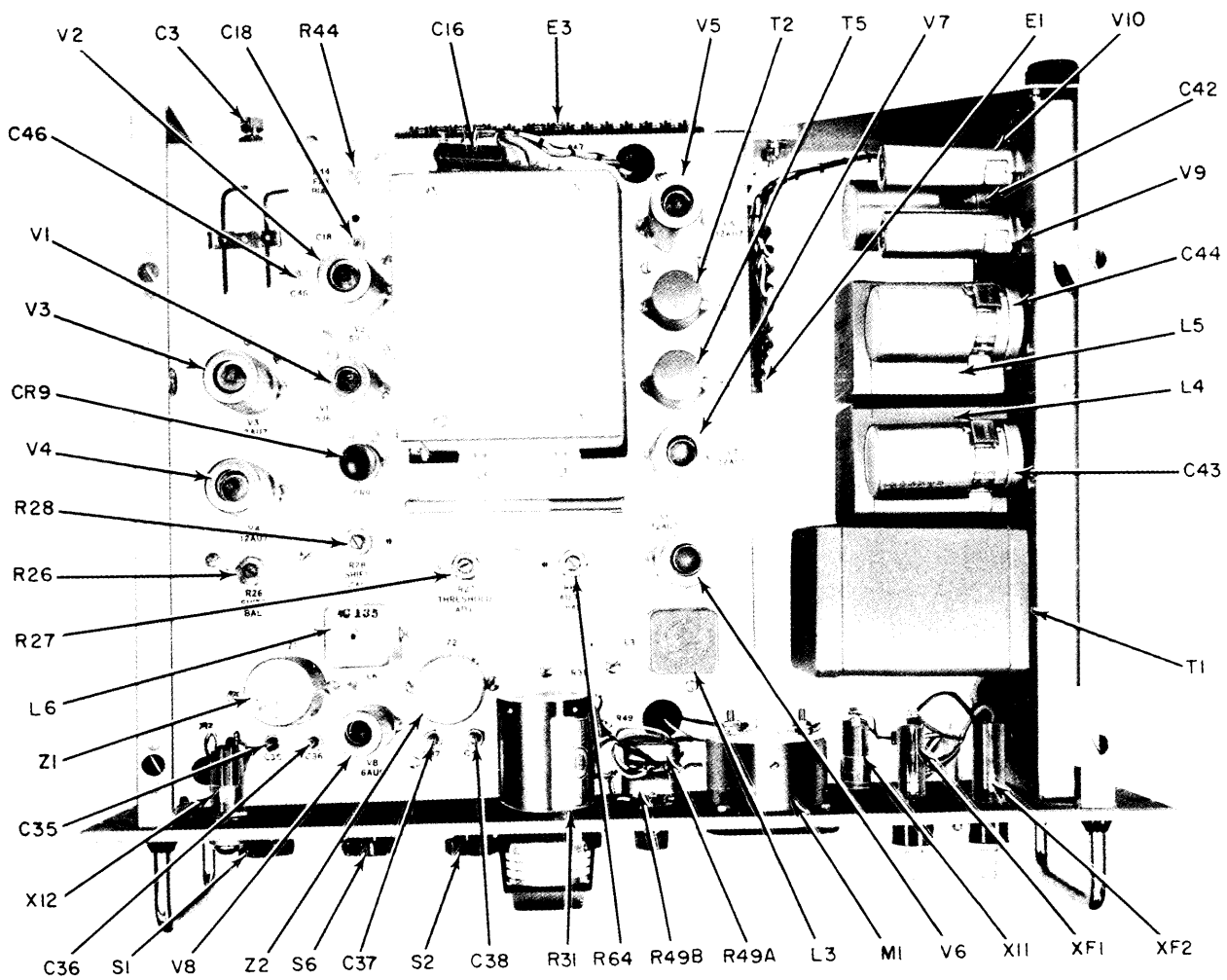

Figure 5-1. Voltage and Resistance Measurements



2025-5-2

Figure 5-2. Front Panel Operating Controls



2025-15

Figure 5-3. Top View of Chassis, Parts Location

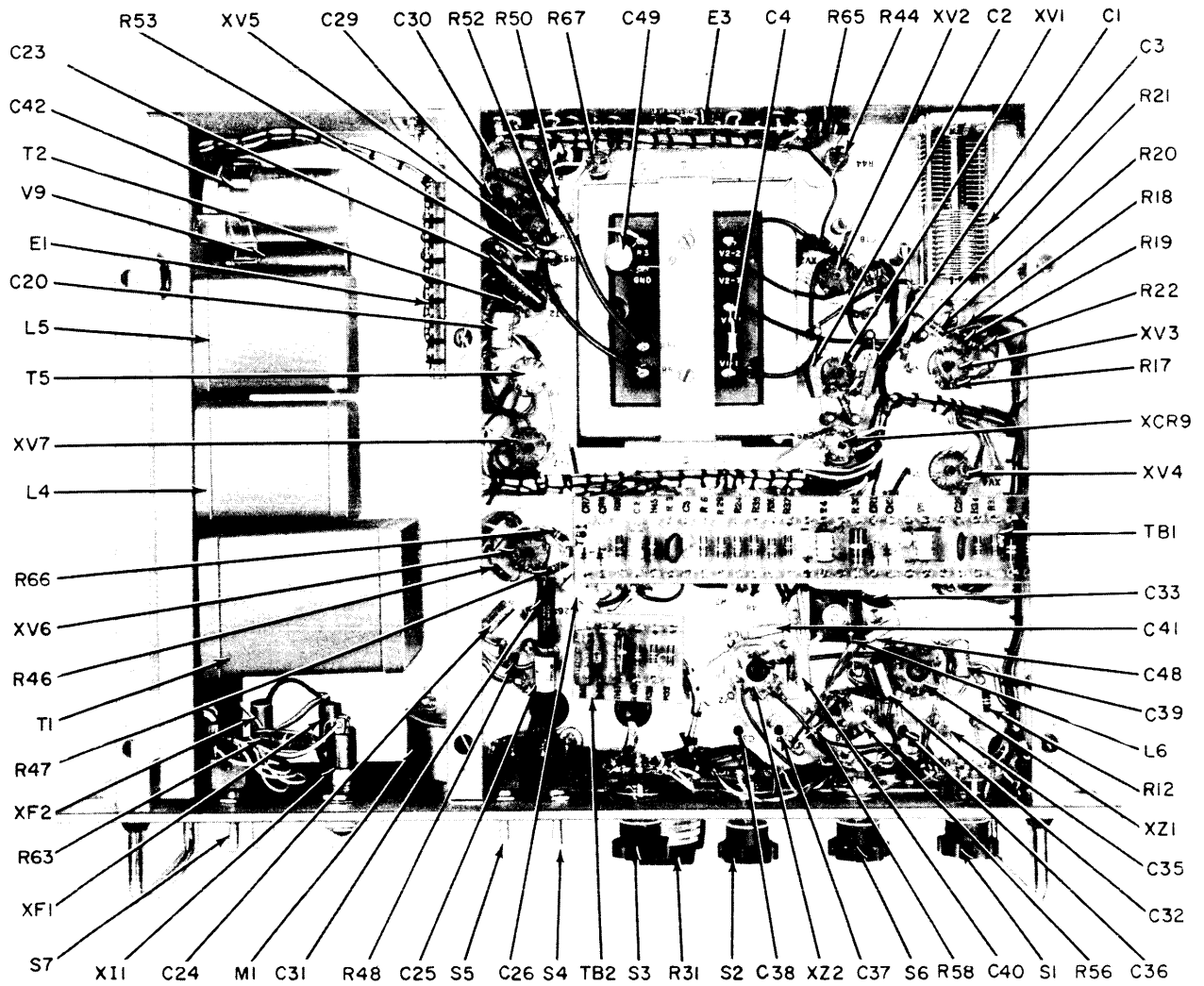

2025-16

Figure 5-4. Bottom View of Chassis, Parts Location

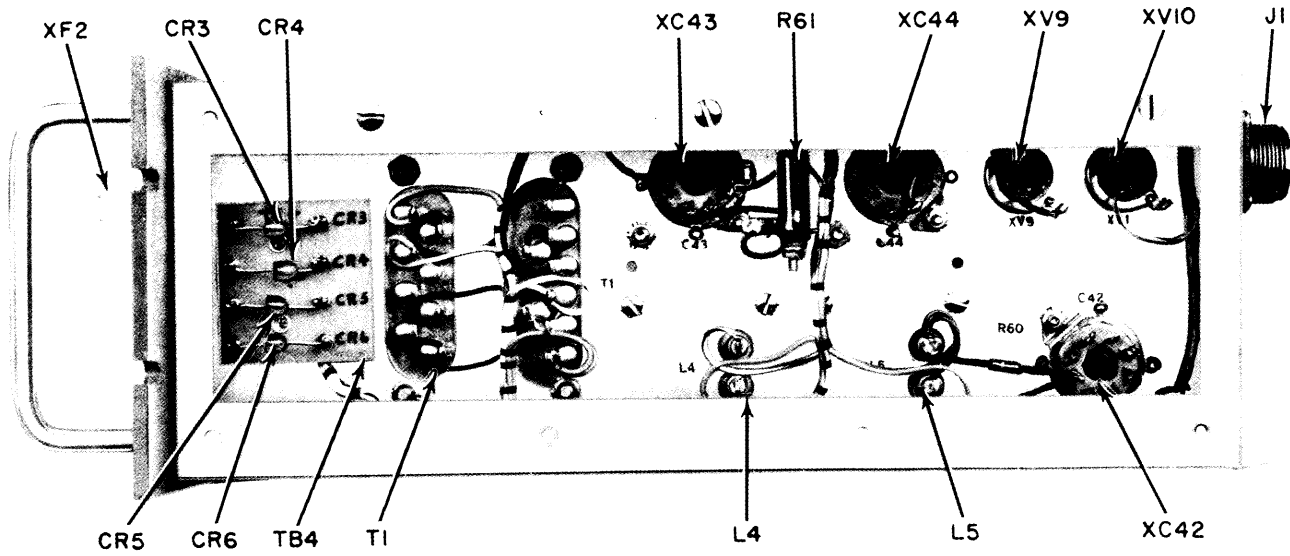

2025-17

Figure 5-5. Right View of Chassis, Parts Location

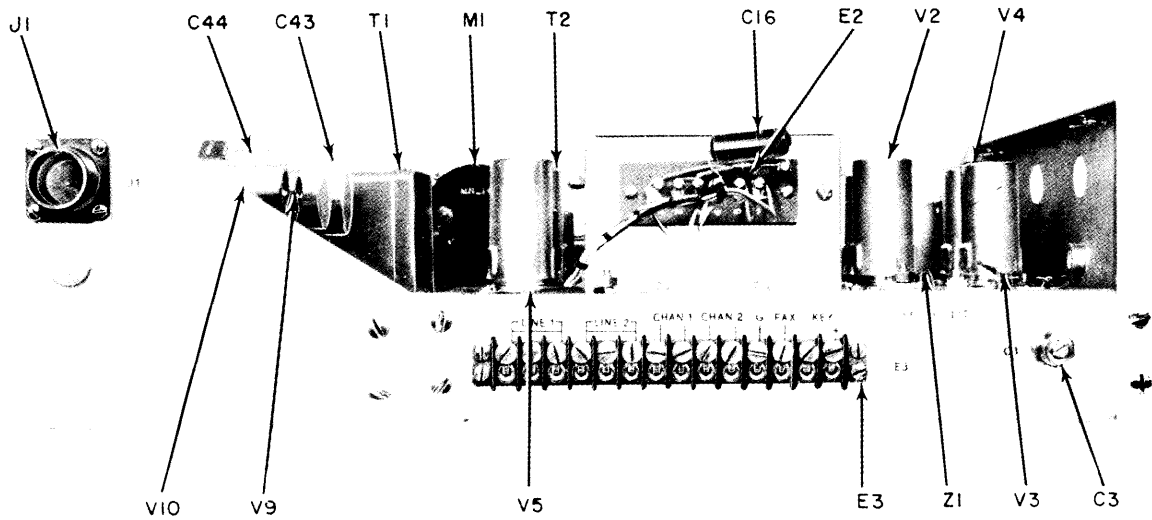

2025-18

Figure 5-6. Rear View of Chassis, Parts Location

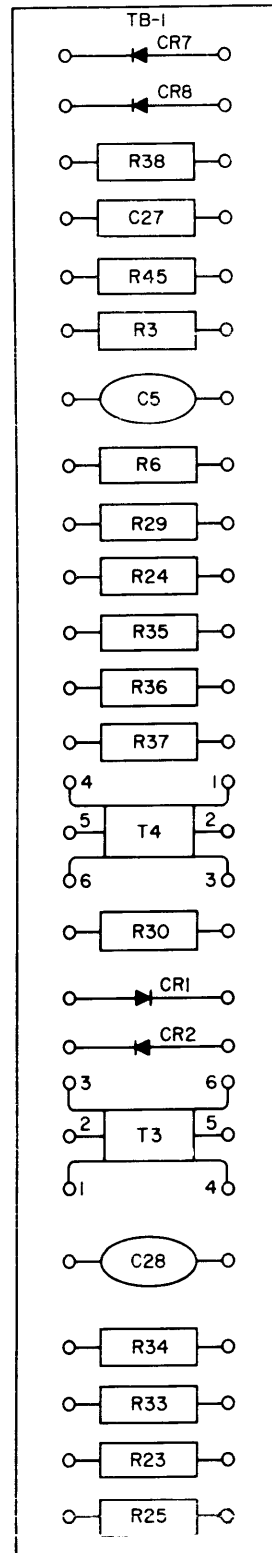
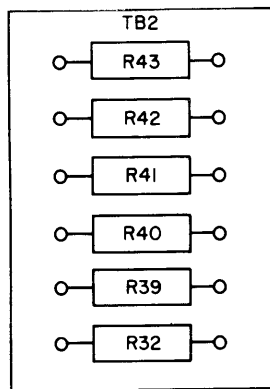

2025-19

Figure 5-7. Terminal Boards, Parts Location

SECTION 6 MAINTENANCE

6-1. GENERAL.

Periodic maintenance is required to keep the TIS in operating condition and includes cleaning procedures, and instructions for testing the electron tubes. Corrective maintenance contains instructions for tuning and aligning the unit after a faulty component has been located and replaced.

6-2. PREVENTIVE MAINTENANCE.

CLEANING. - The TIS should be cleaned quarterly for optimum reliability. To clean the unit, proceed as follows:

- a. Remove unit from rack and place on workbench.
- b. Remove dust covers and inspect interior of unit for frayed insulation, loose connections, grease, dirt and foreign matter.
- c. Clean chassis with airhose and electronic component with carbon-tetrachloride.

WARNING

When using carbon-tetrachloride, make certain area is well ventilated, and if possible, wear rubber gloves. Avoid inhaling fumes and work only a short period at a time.

TUBE TESTING. - The tubes in this unit should be tested at the same time the cleaning procedure is performed. Remove only one tube at a time to avoid placing a similar tube type in another socket. After each tube has been tested and replaced in socket, make certain it seats properly. When replacing unit in rack, make certain connections to terminal block are tight.

6-3. CORRECTIVE MAINTENANCE.

Table 6-1 lists the alignment procedure. A set of alignment tools are provided with the unit and should be used in making all adjustments. Use the

alignment tool to tune the capacitors and the Allen wrenches for the front panel controls and to tune variable reactor L3. In addition to the alignment tools provided, the following test equipment is required.

- a. Hewlett-Packard Voltmeter, Model 410B or equivalent.
- b. Battery supply capable of providing 0 to +20 vdc.
- c. Berkley Counter, Model 550 or equivalent.
- d. Simpson Multimeter, Model 260 or equivalent.
- e. Tektronix Oscilloscope, Model 545A or equivalent.
- f. Lambda Regulated Power Supply, Model 26 or equivalent.
- g. C. P. Clare Relay, Model HG-1002 or equivalent.
- h. Measurements Square Wave Generator, Model 71, or equivalent.

To gain access to the main oven components, proceed as follows:

- (1) Disconnect leads to oven terminal board TB2 (see figure 5-4).
- (2) Remove two screws securing terminal board and lift terminal board out of chassis.

NOTE

The heating elements and thermostatic switch will come out with terminal board.

- (3) Disconnect leads to internal components of oven and remove four screws securing oven housing cover.

- (4) Remove oven casting from housing and separate casting from component board.

TABLE 6-1. ALIGNMENT PROCEDURE

STEP	ACTION	NORMAL INDICATION
1	Test power supply. Terminal strip E1.	<p>a. A-c voltage between terminals 1 and 2 of power supply terminal strip is 6.3 V.</p> <p>b. A-c voltage between terminals 3 and 4 of power supply terminal strip is 115 v.</p> <p>c. D-c voltage to ground at pins 5 and 6 of power supply terminal strip is +150 V.</p> <p>d. D-c voltage to ground at pin 7 of power supply terminal strip is -150 V.</p>
2	Check crystal ovens for proper crystals.	<p>Crystal Y1 is 198.100-kc.</p> <p>Crystal Y2 is 198.000-kc.</p> <p>Crystal Y3 is 197.450-kc.</p>
3	Connect oscilloscope and frequency counter through a 50 uuf capacitor to center tap of L6. Place S6 in 2550 position. Tune L6 for maximum voltage on oscilloscope.	Oscilloscope indicates approx. 12.5 volts peak to peak.
4	Check waveform on oscilloscope for hum.	Hum, should be at least 40 db down.
5	Place S6 in 1900 position. Vary C35.	Frequency counter reads 198.100-kc.
6	Place S6 in 2000 position. Vary C36.	Frequency counter reads 198.000-kc.
7	Place S6 in 2550 position. Vary C37.	Frequency counter reads 197.450-kc.
8	Set C3 to 1/3 maximum. Set C46 to midposition. Set SHIFT CPS control R31 at 000. Set shift calibrate adj. R28 to midposition. Set shift balance adj. R26 to midposition. Set S2 to SPACE. Set S6 to SPARE. Set C18 to 3/4 maximum. Set S1 to FSK. Connect oscilloscope and frequency counter to pin 2 of V5.	200 kc sine wave.
9	Vary C3.	Frequency counter reads 200-kc \pm 10 cps. (Lock shaft of C3 when indication is correct.)
10	Vary C46.	Frequency counter reads 200-kc.
11	Read rf voltage with oscilloscope.	Approximately 6 volts peak to peak. No appreciable distortion or hum is visible.
12	Connect vacuum voltmeter to wiper of shift balance adj. R26. Set meter on 50-volt scale. Adjust meter to center of scale to read \pm volts. Place S2 in SPACE position.	Meter reads +12 v. (Vary R26 to secure this reading.)
13	Place S2 in MARK position.	Meter reads -12 v.

TABLE 6-1. ALIGNMENT PROCEDURE (CONT'D)

STEP	ACTION	NORMAL INDICATION
14A	Set SHIFT CPS control R31 to 1000. Change S2 from MARK to SPACE position.	Frequency counter indicates a frequency change of 1000 cps (+500 cps). Vary SHIFT BALANCE ADJ. R26 to secure shift equal on both sides. Vary shift calibrate adj. R28 to secure shift equal to 500 cycles on both sides.
14B	Set R31 to 800. Change S2 from MARK to SPACE position.	Frequency counter indicates a frequency change of approximately 802 cps.
14C	Set R31 to 600. Change S2 from MARK to SPACE position.	Frequency counter indicates a frequency change of approximately 605 cps.
14D	Set R31 to 500. Change S2 from MARK to SPACE position.	Frequency counter indicates a frequency change of approximately 507 cps.
14E	Set R31 to 400. Change S2 from MARK to SPACE position.	Frequency counter indicates a frequency change of approximately 407 cps.
14F	Set R31 to 300. Change S2 from MARK to SPACE position.	Frequency counter indicates a frequency change of approximately 305 cps.
14G	Set R31 to 200. Change S2 from MARK to SPACE position.	Frequency counter indicates a frequency change of approximately 200 cps.
14H	Set R31 to 100. Change S2 from MARK to SPACE position.	Frequency counter indicates a frequency change of approximately 102 cps.
14I	Set R31 to 050. Change S2 from MARK to SPACE position.	Frequency counter indicates a frequency change of approximately 51 cps.
14J	Set R31 to 000. Change S2 from MARK to SPACE position.	Frequency counter indicates a frequency change of approximately 0 cps.
15	Arrange a test setup as shown in figure 6-1. Place EXCITER CH1 switch S4 in the CW, FAX, FSK position. Place CENTER FREQ CPS control S6 in 1900 position. Set LEVEL ADJ control R49 in midposition. Place S2 in MARK position. Place S1 in FSK position. Set AUDIO BALANCE ADJ. R64 to midposition. Set R31 to 000.	OUTPUT LEVEL meter reads approx. 0 db. LEVEL ADJ control should adjust level from 0 db to full scale.
16A	Place S6 in 1900 position.	Frequency counter reads 1900 cps.
16B	Place S6 in 2000 position.	Frequency counter reads 2000 cps.
16C	Place S6 in 2550 position.	Frequency counter reads 2550 cps.
16D	Place S6 in SPARE position.	Frequency counter reads 0 cps.
17	Set LEVEL ADJ control R49 so that OUTPUT LEVEL meter reads 0 db. Check voltage on oscilloscope.	Oscilloscope indicates voltage of 1.8 volts peak to peak.
18A	Place S6 in 2550 position. Set R31 to 100. Read output frequency with counter.	Frequency counter reads 2500 cps with S2 in SPACE position; 2600 cps with S2 in MARK position.

TABLE 6-1. ALIGNMENT PROCEDURE (CONT'D)

STEP	ACTION	NORMAL INDICATION
18B	Set R31 to 300. Read output frequency with frequency counter.	Frequency counter reads 2400 cps with S2 in SPACE position; 2700 cps with S2 in MARK position.
18C	Set R31 to 500. Read output frequency with frequency counter.	Frequency counter reads 2300 cps with S2 in SPACE position; 2800 cps with S2 in MARK position.
18D	Set R31 to 800. Read output frequency with frequency counter.	Frequency counter reads 2150 cps with S2 in SPACE position; 2950 cps with S2 in MARK position.
18E	Set R31 to 1000. Read output frequency with frequency counter.	Frequency counter reads 2050 cps with S2 in SPACE position; 3050 cps with S2 in MARK position.
19	Place S1 in FAX position. Arrange a test setup as shown in figure 6-2. Place S6 in 1900 position. Adjust FAX bias adj. R44 for output to the frequency counter of 2300 ± 5 cps when FAX input voltage is 0. Adjust C18 for best linearity. Repeat step 10 after each adjustment of C18.	Proper setting of FAX bias adj. R44.
20A	Set FAX input voltage at 0.5 V.	Frequency counter reads $2260 \text{ cps} \pm 5\%$.
20B	Set FAX input voltage at 1.0 V.	Frequency counter reads $2220 \text{ cps} \pm 5\%$.
20C	Set FAX input voltage at 2 V.	Frequency counter reads $2140 \text{ cps} \pm 5\%$.
20D	Set FAX input voltage at 5 V.	Frequency counter reads $1900 \text{ cps} \pm 5\%$.
20E	Set FAX input voltage at 6 V.	Frequency counter reads $1820 \text{ cps} \pm 5\%$.
20F	Set FAX input voltage at 8 V.	Frequency counter reads $1660 \text{ cps} \pm 5\%$.
20G	Set FAX input voltage at 10 V.	Frequency counter reads $1500 \text{ cps} \pm 5\%$.
21	Arrange a test setup as shown in figure 6-3. Place S1 in CW position. Set threshold adj. R27 to midposition. Place S3 in 60 MA position. Short out contacts of relay and adjust keying current to 60 ma. Set square wave generator to 50 cps. Place S6 in 2000 position. Place S2 in LINE position.	Adjust R49 (level adjust) for a reading of 0 db on output level meter.
22	Put frequency counter and oscilloscope on pin 1 of V6A. Vary L3 with an Allen wrench.	Frequency counter reads 1000 cps, oscilloscope indicates ac voltage of 25 volts rms.
23	Adjust R27 (threshold) and R64 (audio balance) for best square wave output.	Adjust R27 (threshold) for 0 volts at unkeyed portion.
24	Short relay and re-read frequency counter and oscilloscope.	Frequency counter reads 1000 cps.
25	Vary square wave generator from 5 cps to 200 cps, checking output wave shape.	

TABLE 6-1. ALIGNMENT PROCEDURE (CONT'D)

STEP	ACTION	NORMAL INDICATION
26	Disconnect keyline and measure level in unkeyed state.	Tone should be 50 db down.
27A	Vary audio balance adj. R64 for best square wave.	
27B	Check waveform at pin 7 of V4.	Approx. 4 volts peak to peak.
27C	Check waveform at pin 2 of V3.	Approx. 16 volts peak to peak.
27D	Check waveform at pin 8 of V3.	Approx. 78 volts peak to peak.
27E	Check waveform at pin 2 of V4.	Approx. 45 volts peak to peak.
27F	Check waveform at pin 3 of V4.	Approx. 10 volts peak to peak.
28A	Place S3 in 20MA position. Use series potentiometer to obtain levels and repeat steps 27a through 27f.	
28B	Place S3 in 100 V position. Use series potentiometer to obtain levels and repeat steps 27a through 27f.	
28C	Place S3 in 50 V position. Use series potentiometer to obtain levels and repeat steps 27a through 27f.	
29	Set S1 to FSK. Set shift to 1000 cps. Check shifted tone for audio distortion. Check from 0 to 1000 cps shift.	Top should be flat \pm 1 db.
30	Connect spectrum analyzer to terminals 7 and 8 at rear of chassis. Place S1 in FSK position. Set R31 to 000. Place S6 in 2000 position. Place S2 in LINE position. Set OUTPUT LEVEL meter to 9 db. Vary R67.	Minimum distortion and hum 40 db down as viewed on the spectrum analyzer.

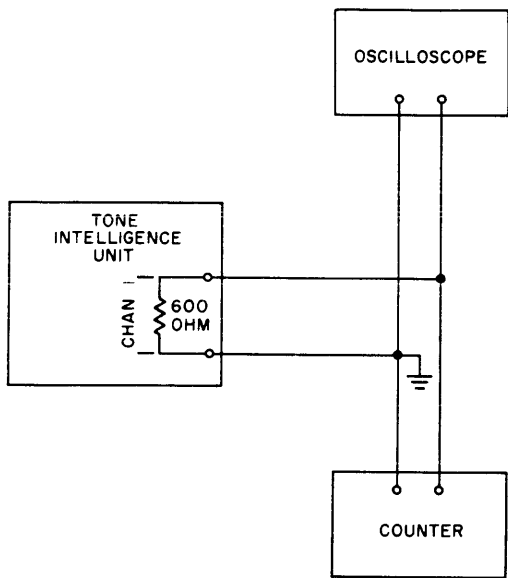

Figure 6-1. Test Setup No. 1

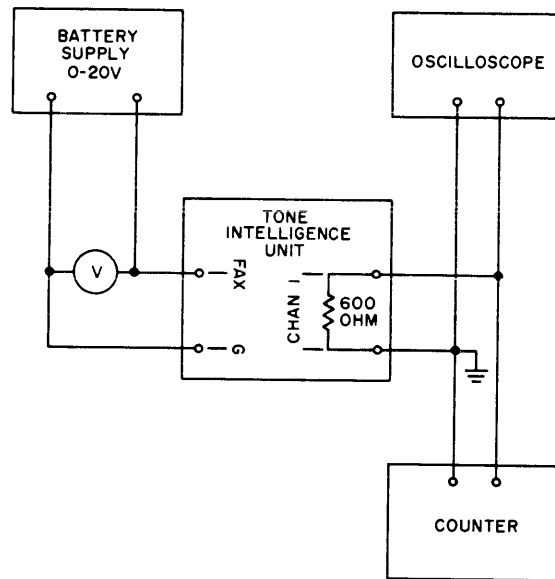

Figure 6-2. Test Setup No. 2

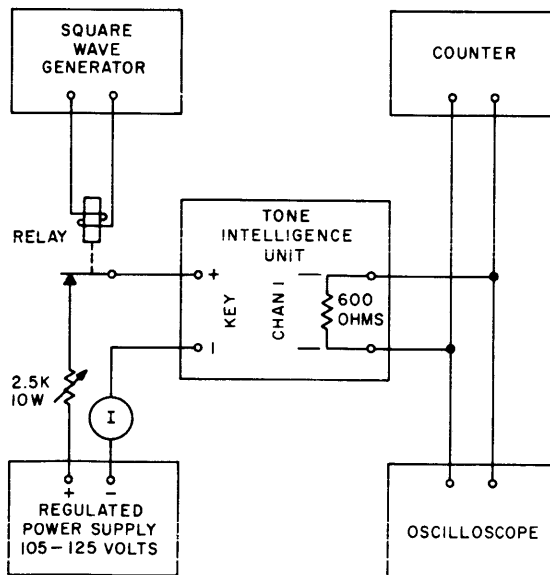

Figure 6-3. Test Setup No. 3

SECTION 7 PARTS LIST

7-1. GENERAL .

Reference designations have been assigned to identify all maintenance parts of the equipment. They are used for marking the equipment (adjacent to the part they identify) and are included on drawings, diagrams and the parts list. The letters of a reference designation indicate the kind of part (generic group), such as resistor, capacitor, electron tube, etc. The number differentiates between parts of the same generic group. Sockets associated with a

particular plug-in device, such as electron tube or fuse, are identified with a reference designation which includes the reference designation of the plug-in device. For example, the socket for fuse F1 is designated XF1. Column 1 lists the reference designations of the various parts in alphabetical and numerical order. Column 2 lists and describes the various parts. Major part assemblies are listed in their entirety; subparts of a major assembly are listed in alphabetical and numerical order with reference to the major assembly. Column 3 lists each Technical Materiel Corporation part number.

REF SYM	DESCRIPTION	TMC PART NO.
C1	CAPACITOR, fixed: mica; 100 uuf, $\pm 10\%$, char. C, 500 wvdc.	CM15F101G03
C2	Same as C1	
C3A, B	CAPACITOR, variable: air dielectric; dual section, 7 to 100 uuf each section.	CB-103-3
C4	CAPACITOR, fixed: ceramic; 15 uuf, ± 0.5 uuf, char. N750, 600 wvdc.	CC-103-1
C5	CAPACITOR, fixed: ceramic disc; 0.01 mfd, 500 wvdc.	CC-100-16
C6	CAPACITOR, fixed: ceramic; 110 uuf, $\pm 2\%$, 500 wvdc.	CC26UJ111G
C7	CAPACITOR, fixed: ceramic; 1000 uuf, $\pm 1\%$, 500 wvdc.	CC-102-4
C8	CAPACITOR, fixed: mica; 100 uuf, $\pm 10\%$, 500 wvdc.	CM20F102G03
C9	CAPACITOR, fixed: mica; 27 uuf, $\pm 2\%$, 500 wvdc.	CM15E270G03YY
C10	Same as C6	
C11	CAPACITOR, fixed: ceramic; 68 uuf, $\pm 5\%$, 500 wvdc.	CC-102-1
C12	Same as C11	
C13	CAPACITOR, fixed: mica; 680 uuf, $\pm 2\%$, char. E, 500 wvdc.	CM20F681G03
C14	Same as C13	
C15	Same as C9	
C16	CAPACITOR, fixed: mylar dielectric; 0.05 mfd, 5%, 400 wvdc.	CN-113-1
C17	Same as C5	
C18	CAPACITOR, variable: glass; 1.0-12.0 uuf, operating temp. -55°C to 125°C , 500 wvdc.	CV-101-3

PARTS LIST (CONT)

REF SYM	DESCRIPTION	TMC PART NO.
C19	Same as C5	
C20	CAPACITOR, fixed: mylar; 0.2 mfd, $\pm 10\%$, 200 wvdc.	CN108C2003K
C21	Same as C5	
C22	Same as C5	
C23	CAPACITOR, fixed: mylar; 0.1 mfd.	CN114R102J
C24	CAPACITOR, fixed: mylar; 0.1 mfd, $\pm 10\%$, 200 wvdc.	CN106C104K
C25	Same as C20	
C26	Same as C20	
C27	Same as C24	
C28	CAPACITOR, fixed: ceramic disc; 0.005 mfd, 500 wvdc.	CC-100-15
C29	CAPACITOR, fixed: mica; 30 uuf, $\pm 5\%$, char. C, 500 wvdc.	CM15C300J03
C30	Same as C29	
C31	CAPACITOR, fixed: mylar; 0.04 uf.	CP106C403-4
C32	CAPACITOR, fixed: mica; 270 uuf, $\pm 2\%$, char. C, 500 wvdc.	CM15F271G03
C33	Same as C5	
C34	Same as C5	
C35	CAPACITOR, variable: glass; 2 to 30 uuf, 1,000 VDC at mid-capacity.	CV-104-1
C36	Same as C35	
C37	Same as C35	
C38	Same as C35	
C39	Same as C24	
C40	Same as C24	
C41	Same as C9	
C42A, B	CAPACITOR, fixed: dry electrolytic; polarized; dual unit; 20 mfd, each section, char. E, 450 wvdc.	CE52E200R
C43A, B	Same as C42A, B	
C44A, B	Same as C42A, B	
C45A, B	CAPACITOR, fixed: ceramic disc; two section; 0.01 mfd, 500 wvdc.	CC100-23
C46	CAPACITOR, variable: glass; 1-8 uuf.	CV101-1

PARTS LIST (CONT)

REF SYM	DESCRIPTION	TMC PART NO.
C47	CAPACITOR, fixed: ceramic; 8 uuf, ± 0.25 uuf; 500 wvdc.	CC21SL080C
C48	CAPACITOR, fixed: mica; 220 uuf, $\pm 2\%$; char. C; 500 wvdc.	CM15F221G03
C49	Same as C5	
C50	CAPACITOR, fixed: paper; 5 mfd, $\pm 10\%$; 600 wvdc.	CN112A504K6
C51	CAPACITOR, fixed: mica; 5 uuf, $\pm 2\%$.	CM15C050J03YY
C52	CAPACITOR, fixed: mylar; 0.2 uf, $\pm 5\%$.	CN114R202J
C53	Same as C52	
C54	CAPACITOR, fixed: electrolytic; 8 uf; 250 wvdc; polarized, tubular metal case w/plastic sleeve.	CE116-1VN
CR1	DIODE, germanium.	1N67
CR2	Same as CR1	
CR3	DIODE, silicon, rectifier: max. 210 volts RMS, max. 600 peak inverse volts.	1N547
CR4	Same as CR3	
CR5	Same as CR3	
CR6	Same as CR3	
CR7	Same as CR1	
CR8	Same as CR1	
CR9	DIODE ASSY, germanium.	DD100
E1	TERMINAL BOARD: barrier type.	TM100-8
E2	TERMINAL STRIP: element.	AX242
E3	TERMINAL BOARD: barrier type.	TM100-14
EV1	SHIELD, ELECTRON TUBE:	TS102U02
EV2	SHIELD, ELECTRON TUBE:	TS103U03
EV3 thru EV7	Same as EV2	
EV8	Same as EV1	
EV9	SHIELD, ELECTRON TUBE:	TS102U03
EV10	Same as EV9	
F1	FUSE, cartridge: time lag; 1 amp.	FU102-1
F2	Same as F1	

PARTS LIST (CONT)

REF SYM	DESCRIPTION	TMC PART NO.
I1	LAMP, neon: miniature; 100-125 watt, T-3-1/4 bulb; bayonet base.	BI100-51H
I2	LAMP, neon: miniature; 110 V, 1/25 watt, T-3-1/4 bulb; bayonet base.	BI100-51
J1	CONNECTOR, RECEPTACLE, ELECTRICAL: male; 3 contacts.	MS2102A16S-5P
L1	COIL, RADIO FREQUENCY: fixed; 250 uhy, ± 1 uhy, Q = 100, test frequency, 790 kc.	CL265
L2	Same as L1	
L3	REACTOR, variable: 0.54-1 hy, 15 ma dc max.	CL261-1
L4	REACTOR, filter: 10 hy, 70 ma; 280 ohms dc resistance.	TF-5006
L5	Same as L4	
L6	COIL, R. F.: tuned; 1.5-3.5 mhy; Q = 50 at 250 kc; consists of 2 capacitors, one 680 uuf, one 1K uuf.	AC-135
L7	COIL, R. F.: 2.5 mhy; 100 ma.	CL-140-1
M1	METER, level indicating.	MR-144
P1	CONNECTOR, receptacle: female; 3 contacts. Part of symbol no. W1.	MS3106A-16S-5S
P2	PLUG, connector: male; 2 prong. Part of symbol no. W1.	PL-171
R1	RESISTOR, fixed: composition; 100 ohms, $\pm 10\%$, 1/2 watt.	RC20GF101K
R2	RESISTOR, fixed: composition; 100,000 ohms, $\pm 10\%$, 1/2 watt.	RC20GF104K
R3	RESISTOR, fixed: composition; 1000 ohms, $\pm 10\%$, 1/2 watt.	RC20GF102K
R4	Same as R2	
R5	Same as R1	
R6	RESISTOR, fixed: composition; 1800 ohms, $\pm 10\%$, 1/2 watt.	RC20GF182K
R7	RESISTOR, fixed: metallized film; 67,000 ohms, $\pm 1\%$, 1/2 watt.	RR-104-673
R8	RESISTOR, fixed: metallized film; 5800 ohms, $\pm 1\%$, 1/2 watt.	RR-104-582
R9	RESISTOR, fixed: wirewound; cartridge heater type, 20 watts at 115 volts ac $\pm 10\%$, 1000 v insulated to shell.	RR-102-1
R10	Same as R9	
R11	Same as R1	
R12	RESISTOR, fixed: composition; 220,000 ohms, $\pm 10\%$, 1/2 watt.	RC20GF224K

PARTS LIST (CONT)

REF SYM	DESCRIPTION	TMC PART NO.
R13	RESISTOR, fixed: composition; 820 ohms, $\pm 10\%$, 1/2 watt.	RC 20GF821K
R14	Same as R13	
R15	RESISTOR, fixed: composition; 3900 ohms, $\pm 10\%$, 1/2 watt.	RC20GF392K
R16	Same as R2	
R17	RESISTOR, fixed: composition; 47,000 ohms, $\pm 10\%$, 1/2 watt.	RC20GF473K
R18	RESISTOR, fixed: composition; 1 megohm, $\pm 10\%$, 1/2 watt.	RC20GF105K
R19	RESISTOR, fixed: composition; 22,000 ohms, $\pm 10\%$, 2 watts.	RC42GF223K
R20	RESISTOR, fixed: composition; 470,000 ohms, $\pm 10\%$, 1/2 watt.	RC20GF474K
R21	Same as R20	
R22	RESISTOR, fixed: composition; 3300 ohms, $\pm 10\%$, 1/2 watt.	RC20GF332K
R23	RESISTOR, fixed: composition; 12,000 ohms, $\pm 10\%$, 1 watt.	RC32GF123K
R24	RESISTOR, fixed: composition; 270,000 ohms, $\pm 10\%$, 1/2 watt.	RC20GF274K
R25	RESISTOR, fixed: composition; 33,000 ohms, $\pm 10\%$, 2 watts.	RC42GF333K
R26	RESISTOR, variable: composition; 10,000 ohms, $\pm 10\%$, 2 watts, w/locking bushing.	RV4LAYS103A
R27	RESISTOR, variable: composition; 100,000 ohms, $\pm 10\%$, 2 watts.	RV4LAYS104A
R28	Same as R26	
R29	RESISTOR, fixed: composition; 150,000 ohms, $\pm 10\%$, 1/2 watt.	RC20GF154K
R30	RESISTOR, fixed: composition; 6800 ohms, $\pm 10\%$, 2 watts.	RC42GF682K
R31	RESISTOR, variable: precision; 10,000 ohms, 0.1%-0.05%, 5 watts.	RP-102-103
R32	Same as R18	
R33	Same as R18	
R34	Same as R17	
R35	RESISTOR, FIXED, COMPOSITION: 22,000 ohms, $\pm 10\%$; 1/2 watt.	RC20GF223K
R36	Same as R35	
R37	RESISTOR, fixed: composition; 10,000 ohms, $\pm 10\%$, 1/2 watt.	RC20GF103K
R38	RESISTOR, fixed: composition; 5600 ohms, $\pm 10\%$, 1/2 watt.	RC20GF562K
R39	Same as R17	

PARTS LIST (CONT)

REF SYM	DESCRIPTION	TMC PART NO.
R40	Same as R2	
R41	RESISTOR, fixed: composition; 2200 ohms, $\pm 10\%$, 2 watts.	RC42GF222K
R42	RESISTOR, fixed: wirewound; 500 ohms, 100 ma dc, 5 watts.	RW-107-28
R43	Same as R42	
R44	RESISTOR, variable: composition; 5000 ohms, $\pm 10\%$, 1/2 watt.	RV106UX8B502A
R45	RESISTOR, fixed: composition; 1500 ohms, $\pm 10\%$, 1/2 watt.	RC20GF152K
R46	Same as R3	
R47	Same as R35	
R48	Same as R35	
R49A, B	RESISTOR, variable: composition; dual unit, 5000 ohms, $\pm 10\%$, 2 watts, w/locking bushing.	RV104ATSA502C
R50	Same as R2	
R51	Same as R13	
R52	Same as R2	
R53	Same as R35	
R54	Same as R35	
R55	NOT USED	
R56	Same as R20	
R57	RESISTOR, FIXED, COMPOSITION: 220 ohms, $\pm 10\%$, 1/2 watt.	RC20GF221K
R58	Same as R2	
R59	RESISTOR, fixed: composition; 1000 ohms, $\pm 10\%$, 2 watts.	RC42GF102K
R60	Same as R3	
R61	RESISTOR, fixed: wirewound; 1000 ohms, $\pm 5\%$, 10 watts.	RW-109-24
R62	RESISTOR, fixed: composition; 10 ohms, $\pm 10\%$, 1/2 watt.	RC20GF100K
R63	RESISTOR, fixed: composition; 100,000 ohms, $\pm 10\%$, 2 watts.	RC42GF104K
R64	RESISTOR, variable: comp; 500 ohms, $\pm 10\%$, 2 watts.	RV4LAYS501A
R65	RESISTOR, fixed: comp; 47,000 ohms, $\pm 10\%$, 1 watt.	RC32GF473K
R66	RESISTOR, variable: comp; 50K, $\pm 10\%$, 1/2 watt.	RV106UX8B503A
R67	RESISTOR, variable: comp; 250 Ω , $\pm 10\%$, 1/2 watt.	RV106UX8B251A

PARTS LIST (CONT)

REF SYM	DESCRIPTION	TMC PART NO.
R68	RESISTOR, fixed: comp; 15K, $\pm 10\%$, 1/2 watt.	RC20GF153K
R69	Same as R57	
R70	RESISTOR, fixed: composition; 470 ohms, $\pm 10\%$, 1/2 watt.	RC20GF471K
R71	Same as R70	
S1	SWITCH, ROTARY: 1 section; 3 positions; bakelite insulation; contacts and wipers silver plated; 1/4 in. drive shaft, 7/8 in. lg, flatted 3/8 in.	SW148
S2	SWITCH, rotary: non-shorting; single section, one pole, 3 positions, 1-5/16 in. wafers.	SW-111
S3	SWITCH, rotary: 4 positions; 2 poles, 1 section, non-shorting contacts.	SW-120
S4	SWITCH, toggle: DPDT; 6 amps, 250 volts.	ST-22N
S5	Same as S4	
S6	SWITCH, rotary: 1 section; 4 positions, angle of throw 60°.	SW-281
S7	SWITCH, toggle: DPST; 6 amps, 250 VAC.	ST-22K
S8	SWITCH, thermostatic: operate at 70°C, $\pm 2^\circ\text{C}$.	SS-100-2
T1	TRANSFORMER, power: hermetically sealed; insulation - all windings insulated for 1000 volts; primary winding taps - 105V, 115V, 125V, 210V, 230V, 50/60 cps, 1 phase; secondary winding taps #1 175-0-175 V RMS, 100 ma dc operating into 35 uf capacitor input; #2 6.3 V at 3.6 amp CT; #3 -6.3 V at 1.0 amp; #4 6.3 V at 2.5 amp.	TF-227
T2	TRANSFORMER, audio: primary 20,000 ohms CT; secondary 150, 600 ohms; 4 ma dc in primary; ± 2 db, 200 to 10,000 cps.	TF-138
T3	TRANSFORMER, pulse: 3 windings; 10 uhy, $\pm 20\%$, 500 wvdc.	TF-228B5
T4	Same as T3	
T5	Same as T2	
V1	TUBE, electron: duo-triode; 7 pin miniature.	6J6A
V2	TUBE, electron: dual triode; 9 pin miniature.	5963
V3	TUBE, electron: medium-mu duo-triode; 9 pin miniature.	12AU7A
V4	Same as V3	
V5	Same as V3	
V6	Same as V3	
V7	Same as V3	

PARTS LIST (CONT)

REF SYM	DESCRIPTION	TMC PART NO.
V8	TUBE, electron: sharp cutoff RF pentode; 7 pin miniature.	6AG5
V9	TUBE, electron: voltage regulator; 7 pin miniature.	0A2
V10	Same as V9	
W1	CABLE ASSY., power: coiled 2 conductor, retractible to 1" - 0"; consists of 2 connectors, symbol nos. P1, P2.	CA581-1
XC42	SOCKET, electron tube: octal.	TS165P01
XC43	Same as XC42	
XC44	Same as XC42	
XCR9	SOCKET, electron tube: 7 pin miniature; bottom mounting, bakelite, mica filled insulation, with center shield.	TS-130-MPW
XF1	FUSEHOLDER, lamp: indicating; 100 to 250 v, 20 amps, consisting of neon lamp w/clear knob and resistor 220,000 ohms.	FH-104-3
XF2	Same as XF1	
XI1	LIGHT, indicator: w/red frosted lens; for miniature bayonet base T-3-1/4 bulb.	TS-106-1
XI2	LIGHT, indicator: w/clear white lens; for miniature bayonet base T-3-1/4 bulb.	TS-106-2
XV1	SOCKET, electron tube: 7 pin miniature.	TS102P01
XV2	SOCKET, electron tube: 9 pin miniature.	TS103P01
XV3	Same as XV2	
XV4	Same as XV2	
XV5	Same as XV2	
XV6	Same as XV2	
XV7	Same as XV2	
XV8	Same as XV1	
XV9	Same as XV1	
XV10	Same as XV1	
XZ1	Same as XC42	
XZ2	Same as XC42	
Y1	CRYSTAL, quartz: 198.100 kc.	CR47A/U-198. 100KC
Y2	CRYSTAL, quartz: 198.000 kc.	CR47A/U-198. 000KC

PARTS LIST (CONT)

REF SYM	DESCRIPTION	TMC PART NO.
Y3	CRYSTAL, quartz: 197.450 kc.	CR47A/U-197. 450KC
Z1	OVEN, crystal: 6.3 v, 7.5 watt heater; 75°C ±2°C; octal base.	PO-158-1
Z2	Same as Z1	

SECTION 8
SCHEMATIC DIAGRAMS

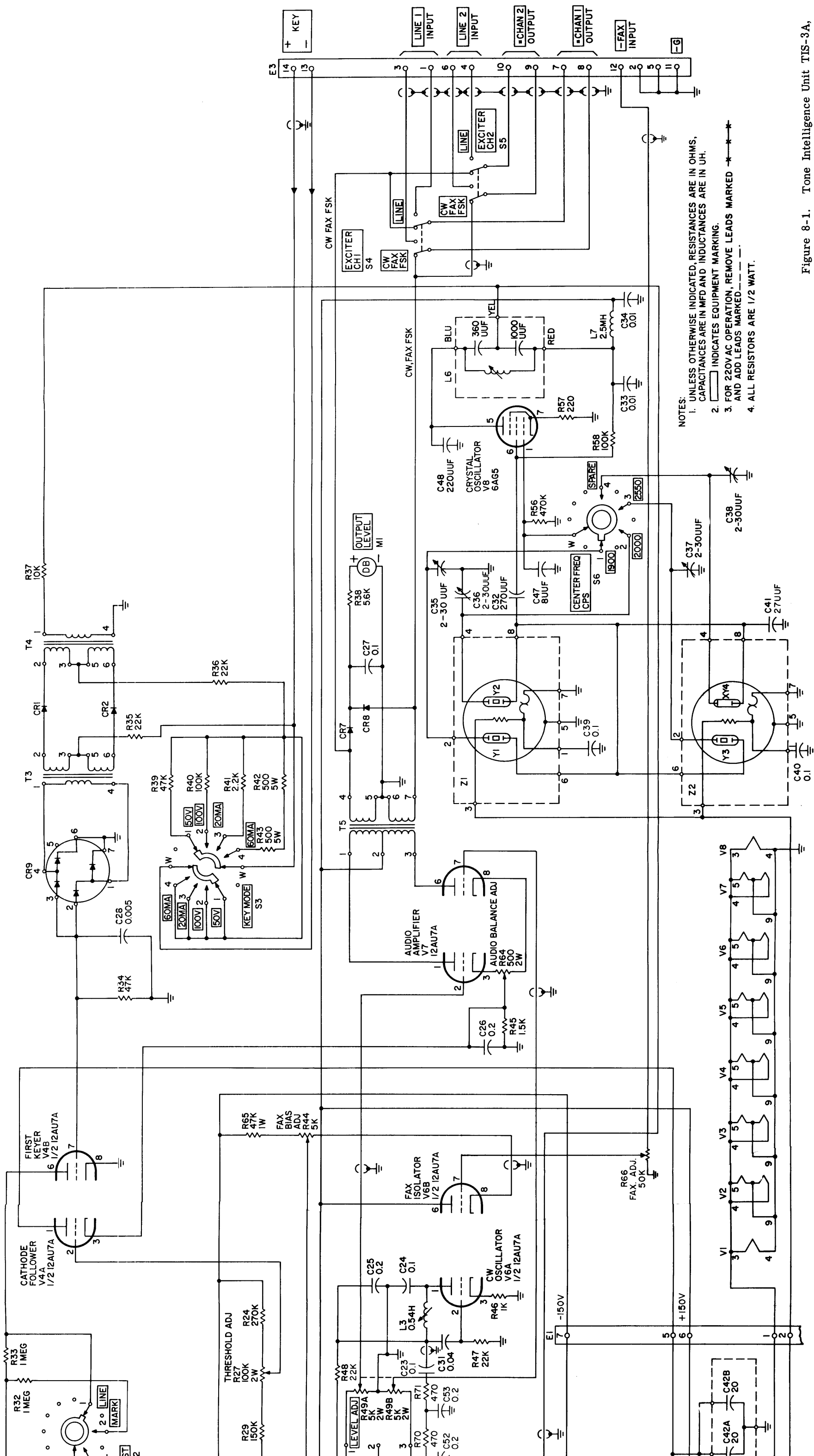

- NOTES:
1. UNLESS OTHERWISE INDICATED, RESISTANCES ARE IN OHMS, CAPACITANCES ARE IN MFD AND INDUCTANCES ARE IN UH.
 2. INDICATES EQUIPMENT MARKING.
 3. FOR 220V AC OPERATION, REMOVE LEADS MARKED AND ADD LEADS MARKED .
 4. ALL RESISTORS ARE 1/2 WATT.

Figure 8-1. Tone Intelligence Unit TIS-3A, Detailed Schematic Diagram

