

★  
UNCLASSIFIED

TECHNICAL MANUAL

*for*

REMOTE CONTROL AMPLIFIER  
MODEL RTC



THE TECHNICAL MATERIEL CORPORATION

MAMARONECK, N. Y.

OTTAWA, ONTARIO

★





# THE TECHNICAL MATERIEL CORPORATION

C O M M U N I C A T I O N S   E N G I N E E R S

700 FENIMORE ROAD

MAMARONECK, N. Y.

## Warranty

The Technical Materiel Corporation, hereinafter referred to as TMC, warrants the equipment (except electron tubes, fuses, lamps, batteries and articles made of glass or other fragile or other expendable materials) purchased hereunder to be free from defect in materials and workmanship under normal use and service, when used for the purposes for which the same is designed, for a period of one year from the date of delivery F.O.B. factory. TMC further warrants that the equipment will perform in a manner equal to or better than published technical specifications as amended by any additions or corrections thereto accompanying the formal equipment offer.

TMC will replace or repair any such defective items, F.O.B. factory, which may fail within the stated warranty period, PROVIDED:

1. That any claim of defect under this warranty is made within sixty (60) days after discovery thereof and that inspection by TMC, if required, indicates the validity of such claim to TMC's satisfaction.
2. That the defect is not the result of damage incurred in shipment from or to the factory.
3. That the equipment has not been altered in any way either as to design or use whether by replacement parts not supplied or approved by TMC, or otherwise.
4. That any equipment or accessories furnished but not manufactured by TMC, or not of TMC design shall be subject only to such adjustments as TMC may obtain from the supplier thereof.

Electron tubes furnished by TMC, but manufactured by others, bear only the warranty given by such other manufacturers. Electron tube warranty claims should be made directly to the manufacturer of such tubes.

TMC's obligation under this warranty is limited to the repair or replacement of defective parts with the exceptions noted above.

At TMC's option any defective part or equipment which fails within the warranty period shall be returned to TMC's factory for inspection, properly packed with shipping charges prepaid. No parts or equipment shall be returned to TMC, unless a return authorization is issued by TMC.

No warranties, express or implied, other than those specifically set forth herein shall be applicable to any equipment manufactured or furnished by TMC and the foregoing warranty shall constitute the Buyers sole right and remedy. In no event does TMC assume any liability for consequential damages, or for loss, damage or expense directly or indirectly arising from the use of TMC Products, or any inability to use them either separately or in combination with other equipment or materials or from any other cause.

### *PROCEDURE FOR RETURN OF MATERIAL OR EQUIPMENT*

Should it be necessary to return equipment or material for repair or replacement, whether within warranty or otherwise, a return authorization must be obtained from TMC prior to shipment. The request for return authorization should include the following information:

1. Model Number of Equipment.
2. Serial Number of Equipment.
3. TMC Part Number.
4. Nature of defect or cause of failure.
5. The contract or purchase order under which equipment was delivered.

### *PROCEDURE FOR ORDERING REPLACEMENT PARTS*

When ordering replacement parts, the following information must be included in the order as applicable:

1. Quantity Required.
2. TMC Part Number.
3. Equipment in which used by TMC or Military Model Number.
4. Brief Description of the Item.
5. The *Crystal Frequency* if the order includes crystals.

### *PROCEDURE IN THE EVENT OF DAMAGE INCURRED IN SHIPMENT*

TMC's Warranty specifically excludes damage incurred in shipment to or from the factory. In the event equipment is received in damaged condition, the carrier should be notified immediately. Claims for such damage should be filed with the carrier involved and not with TMC.

All correspondence pertaining to Warranty Claims, return, repair, or replacement and all material or equipment returned for repair or replacement, within Warranty or otherwise, should be addressed as follows:

THE TECHNICAL MATERIEL CORPORATION  
Engineering Services Department  
700 Fenimore Road  
Mamaroneck, New York

★  
UNCLASSIFIED

TECHNICAL MANUAL

*for*

REMOTE CONTROL AMPLIFIER  
MODEL RTC



THE TECHNICAL MATERIEL CORPORATION

MAMARONECK, N. Y.

OTTAWA, ONTARIO

UNCLASSIFIED

TECHNICAL MANUAL

REMOTE CONTROL AMPLIFIER  
MODEL RTC



THE TECHNICAL MATERIEL CORPORATION

OTTAWA, ONTARIO

MAMARONECK, N. Y.

Copyright, 1959  
THE TECHNICAL MATERIEL CORP.  
Mamaroneck, New York

## TABLE OF CONTENTS

### MODEL RTC

Paragraph	Page	<b>SECTION III — INSTALLATION AND OPERATION</b>	
<b>SECTION I — GENERAL DESCRIPTION</b>		3-1. Installation	3-1
1-1. Purpose and Basic Principles	1-1	3-2. Unpacking	3-1
1-2. Description of Unit	1-1	3-3. Power Supply	3-1
1-3. Technical Specifications	1-1	3-4. Electrical Connections	3-1
		3-5. Operation	3-3
<b>SECTION II — THEORY OF OPERATION</b>		<b>SECTION IV — MAINTENANCE</b>	
2-1. General Description of Circuits	2-1	4-1. General	4-1
2-2. Circuit Analysis	2-3	4-2. Operators Maintenance and Preventive Maintenance	4-1
		4-3. Output Balance Adjustment	4-1
<b>SECTION V — ELECTRICAL PARTS LIST</b>			

### LIST OF ILLUSTRATIONS

Figure	Page	Figure	Page
<b>SECTION I — GENERAL DESCRIPTION</b>		<b>SECTION III — INSTALLATION AND OPERATION</b>	
1-1. Front View Model RTC	ii	3-1. Terminal Board Wiring	3-1
<b>SECTION II — THEORY OF OPERATION</b>		3-2. Interconnect Diagram, RTC to GPT-750	3-2
2-1. Block Diagram, Normal Clip Mode	2-1	3-3. Microphone Connections	3-2
2-2. Block Diagram, MCW Mode	2-1	<b>SECTION IV — MAINTENANCE</b>	
2-3. Simplified Diagram, Microphone Amplifier Circuit	2-2	4-1. Voltage Chart Model RTC	4-2
2-4. Simplified Diagram, Limiter-oscillator Circuit with S802 in CLIP position	2-2	<b>SECTION V — ELECTRICAL PARTS LIST</b>	
2-5. Typical Simplified Diagram, Limiter-oscillator Circuit with S802 in any Tone position	2-3	5-1. Front View Model RTC	5-9
2-6. Simplified Diagram, Phase Inverter and Output Amplifier Circuit	2-3	5-2. Rear View Model RTC	5-10
2-7. Simplified Diagram, Keyer Circuit	2-4	5-3. Top View Model RTC	5-11
2-8. Simplified Diagram, Metering Circuit	2-4	5-4. Bottom View Model RTC	5-12
		5-5. Terminal Board Layout	5-13
		5-6. Schematic Diagram	5-15



Figure 1-1. Front View, Model RTC

PH-475

## SECTION I GENERAL DESCRIPTION

### 1-1. PURPOSE AND BASIC PRINCIPLES

1-1-1. The Model RTC, Remote Control Amplifier, is a multi-purpose unit providing low level audio amplification, selectable peak clipping, and tone output for MCW, or sidetone for CW. The unit also makes possible remote keying, break-in, and other semi-remote transmitter control functions.

1-1-2. The RTC is intended for use with AM transmitters such as the TMC Models GPT-750-1 or GPT-750-2. The audio output will provide a continuously variable output up to +6 dbm at 600 ohm impedance to drive the modulator.

1-1-3. Input is provided for a high impedance dynamic or crystal microphone.

### 1-2. DESCRIPTION OF UNIT

1-2-1. The Model RTC is shown in Figure 1-1. The panel is 19 inches long by 8-3/4 inches high and finished in TMC grey enamel. The chassis extends 14 inches behind the front panel, and is self supporting. The RTC is available in a case as shown in Figure 1-1, or may be removed from case for standard 19 inch rack mounting.

1-2-2. All operational controls are located on the front panel. CLIPPER adjusts the amount of clipping. FUNCTION selects normal or clipper functions or a choice of three MCW or CW sidetone frequencies. GAIN adjusts the audio level for the desired percentage of modulation. OPERATE-STANDBY REMOTE switch provides remote control of the transmitter.

1-2-3. The equipment is manufactured in accordance with JAN/MIL specifications wherever practicable. All parts and assemblies meet or exceed the highest quality standards.

### 1-3. TECHNICAL SPECIFICATIONS

#### OUTPUT LEVEL:

0 Volts up to +6 dbm, continuously variable.

#### OUTPUT IMPEDANCE:

600 ohms balanced or unbalanced to ground.

#### INPUT LEVEL:

-50 db for full output.

#### INPUT IMPEDANCE:

.5 megohm.

#### FREQUENCY RESPONSE:

±2 db from 100 to 7500 cps (when clipper is not being used).

#### DISTORTION:

Less than 2% total harmonic (when clipper is not being used).

#### CLIPPING CHARACTERISTIC:

9-20 db continuously adjustable.

#### CLIPPER FILTER:

High pass filter at low level end-  
200 cps cutoff.

Low pass filter at high level end-  
3000 cps cutoff.

#### MCW OUTPUT:

Three selectable tones - 500, 1000, 1500 cps.

#### MCW KEYING:

Electronic - contacts or DC to ground.

#### SIDETONE OUTPUT:

Three selectable tones - 500, 1000, 1500 cps derived from MCW oscillator.

#### RECEIVER MUTING:

SPDT relay contacts provided.

#### PANEL CONTROLS:

POWER ON/OFF switch

OPERATE/STANDBY REMOTE switch

FUNCTION switch

KEY jack

MICROPHONE Input with Push-to-Talk feature

Pilot Light

PHONES jack (Monitor)

CLIPPER control

GAIN control

#### ACCESSORIES PROVIDED:

Cable, interconnect, RTC to GPT-750-1 or

GPT-750-2, TMC Part Number CA-274-(\*).  
\*Length in feet required. Plug, microphone,  
TMC Part Number PL-132-3.

**POWER REQUIREMENT:**  
115/230 volts,  $\pm 10\%$ , 50/60 cps,  
50 watts, single phase

**TUBE COMPLEMENT:**

1 each 12AX7  
2 each 12AT7  
1 each 12AU7  
1 each 5Y3

**WEIGHT:**

35 pounds net, 84 pounds packed for shipment.

**SIZE:**

Cabinet mounted - 10'' x 15'' x 20''.  
Shipping dimensions - 16'' x 20-1/2'' x 26''.

## SECTION II THEORY OF OPERATION

### 2-1. GENERAL DESCRIPTION OF CIRCUITS

2-1-1. The Model RTC may be operated in any of four modes. They are normal AM, AM with limiting, MCW with a choice of three tones, or CW keying with a choice of three sidetones.

2-1-2. When the FUNCTION switch, S802 is in the NORMAL position, normal amplitude modulation operation is obtained. The signal from a mike plugged into the front panel microphone jack, J801, is amplified by V801, V803A and V804.

2-1-3. When the FUNCTION switch, S802, is in the CLIP position, V802, a balanced limiter, is

included in the amplifier chain. The degree of clipping is adjustable by R807, CLIPPER control.

2-1-4. When the FUNCTION switch, S802, is in any of the TONE positions, V802B operates as a Colpitts oscillator with a choice of three different audio frequencies. The output of V802B is amplified by V803A and V804. The output stage, V804, is keyed by V803B which is operated by a key connected to the KEY jack on the front panel.

2-1-5. In all modes of operation except CW the gain, and therefore the amount of modulation, of the transmitter may be adjusted by the GAIN control. The output level may be read from the Percent Modulation Meter, M801. When the modu-

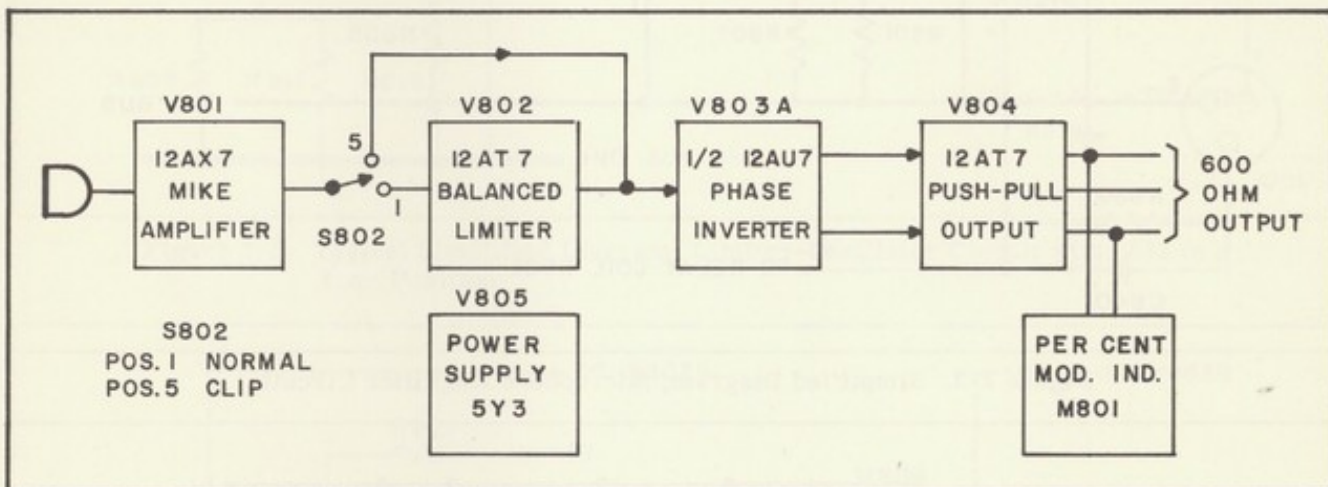

Figure 2-1. Block Diagram, Normal CLIP Mode

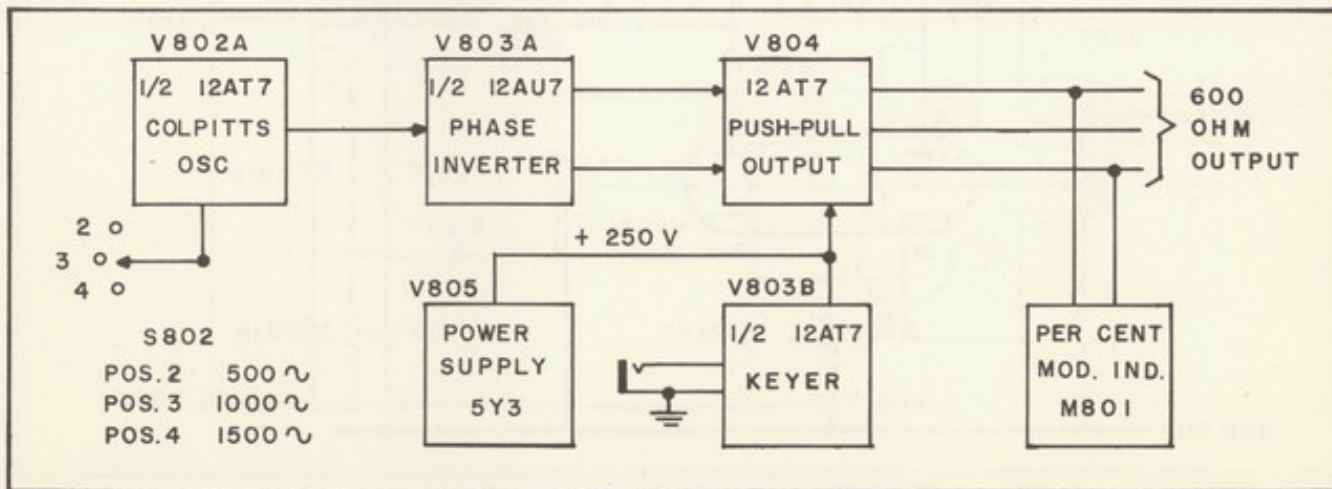

Figure 2-2. Block Diagram, MCW Mode

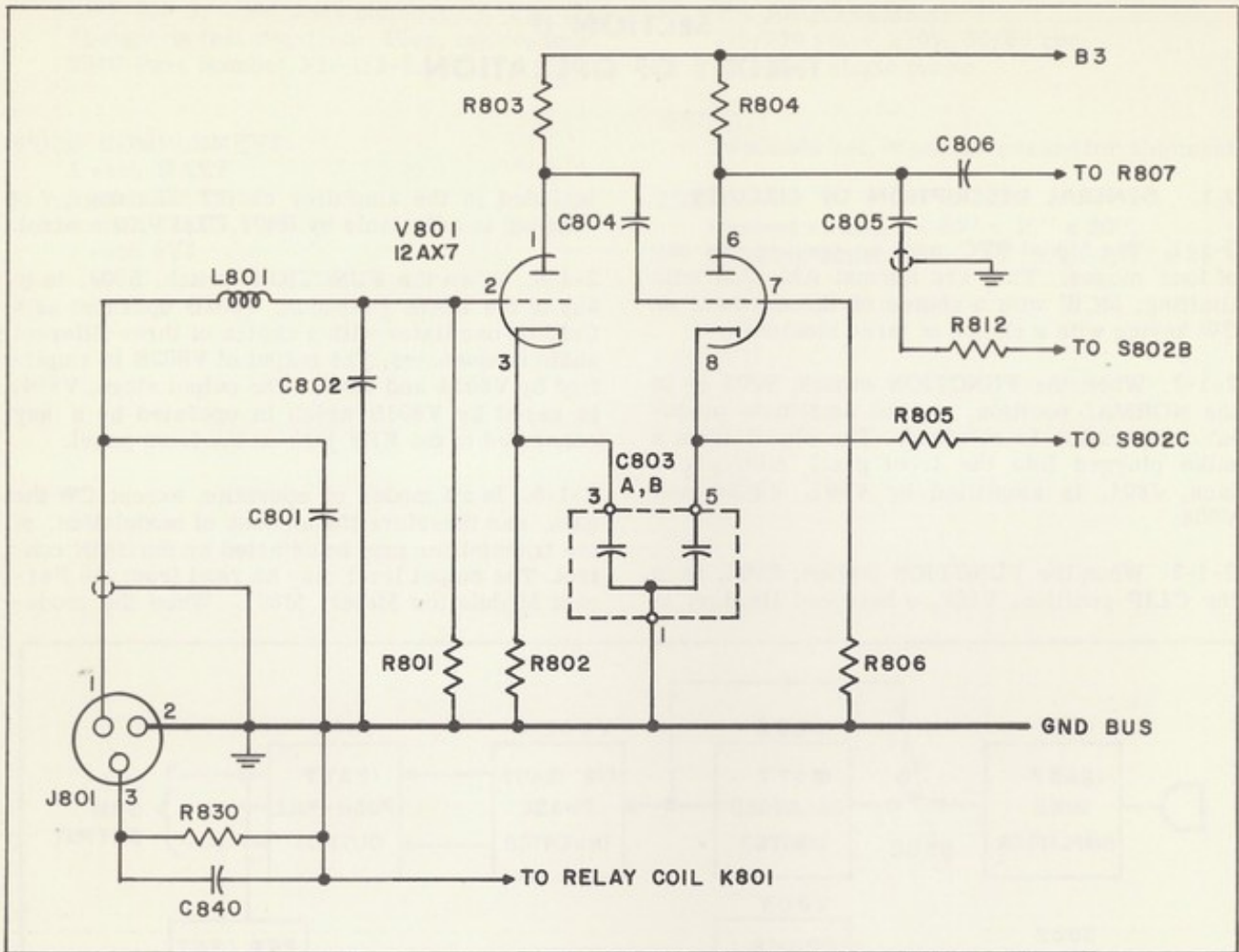

Figure 2-3. Simplified Diagram, Microphone Amplifier Circuit

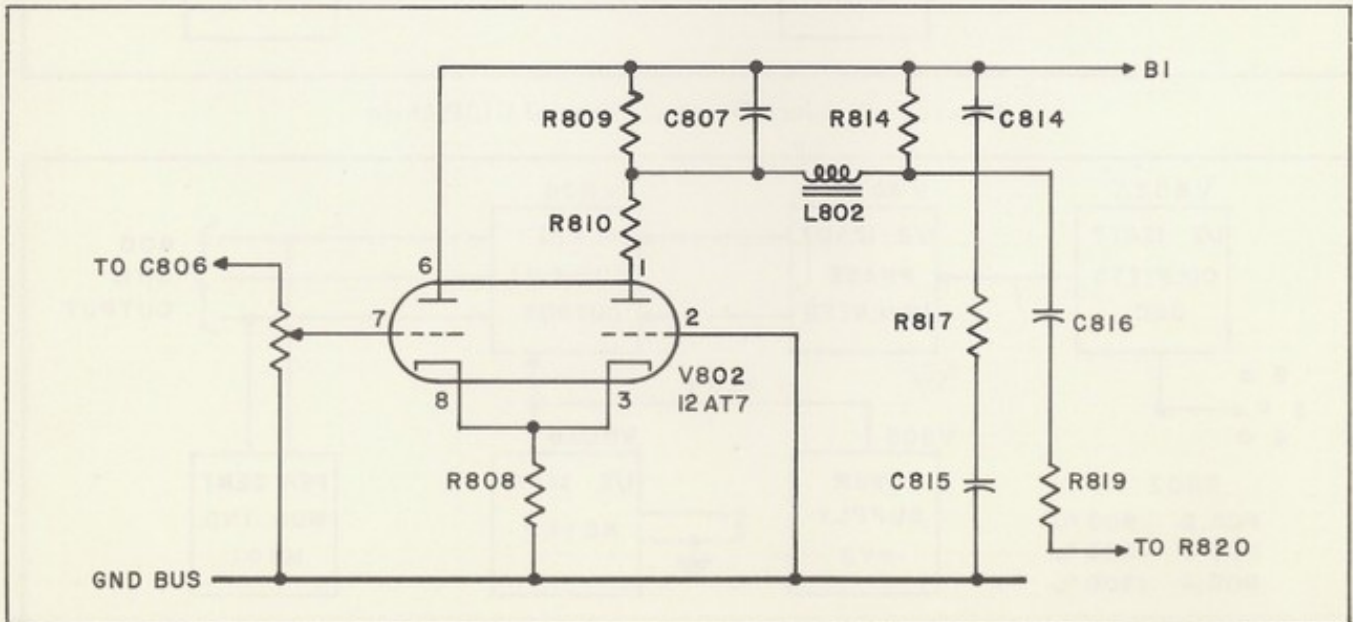

Figure 2-4. Simplified Diagram, Limiter-Oscillator Circuit with S802 in CLIP position

lator gain is adjusted properly, the meter will read directly the transmitter percentage of modulation.

2-1-6. Headphones may be plugged into the PHONES jack, J803, for sidetone operation or for monitor of the output.

## 2-2. CIRCUIT ANALYSIS

2-2-1. THE MICROPHONE AMPLIFIER (V801 A & B). C801, L801 and C802 serve as a low pass filter which prevents radio frequencies from entering the audio stages. The amplifier is a simple audio voltage amplifier. The cathode

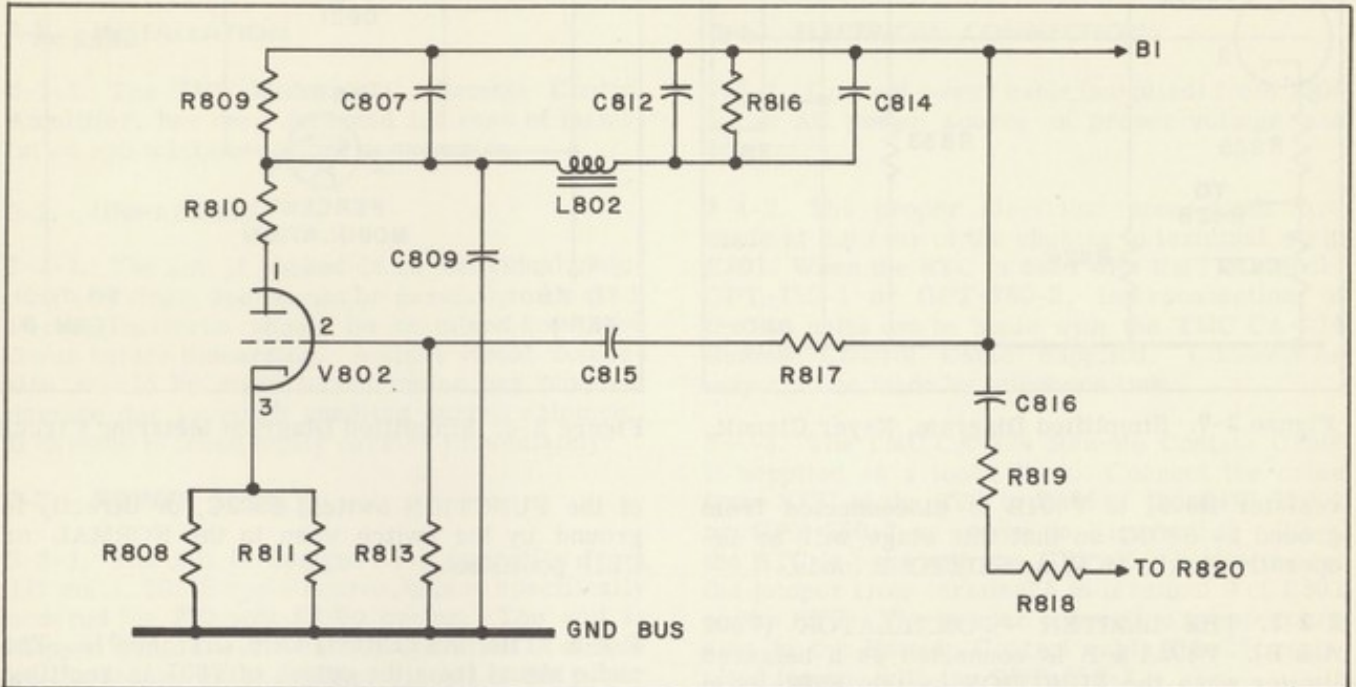

Figure 2-5. Typical Simplified Diagram, Limiter-Oscillator Circuit with S802 in a Tone Position

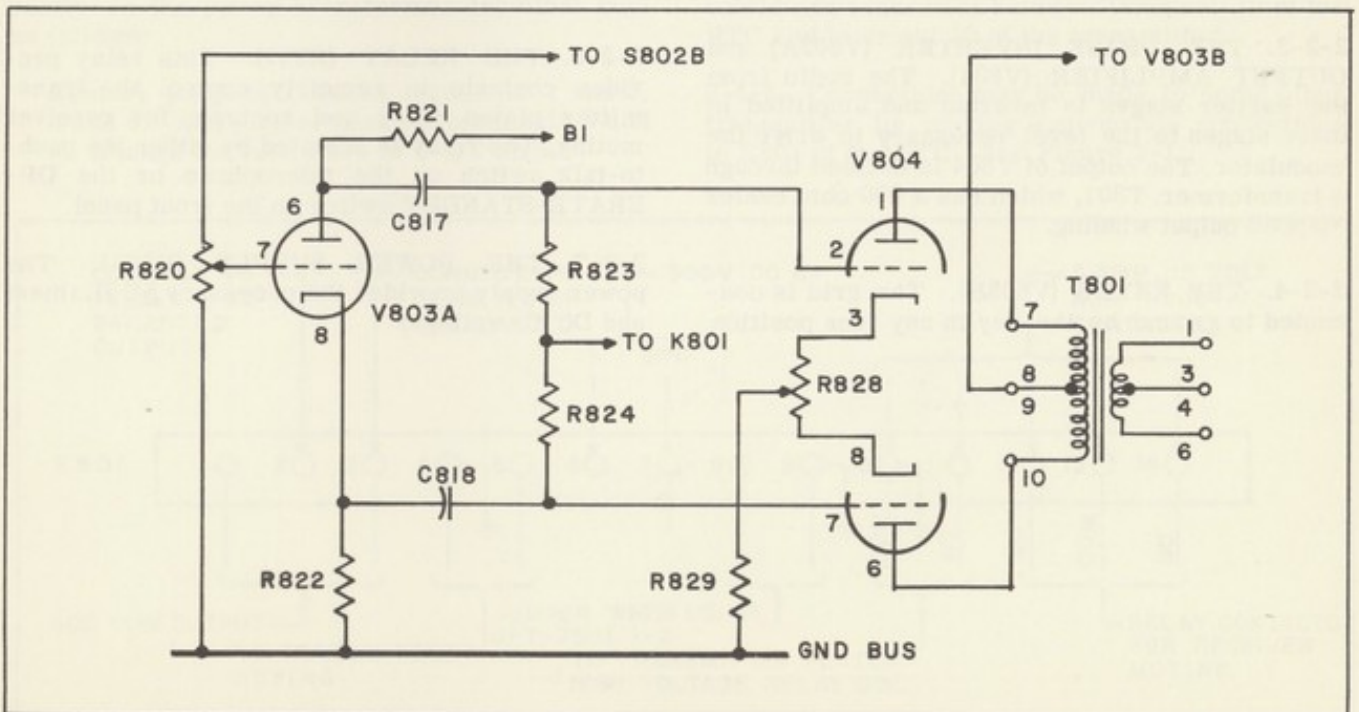

Figure 2-6. Simplified Diagram, Phase Inverter and Output Amplifier Circuit

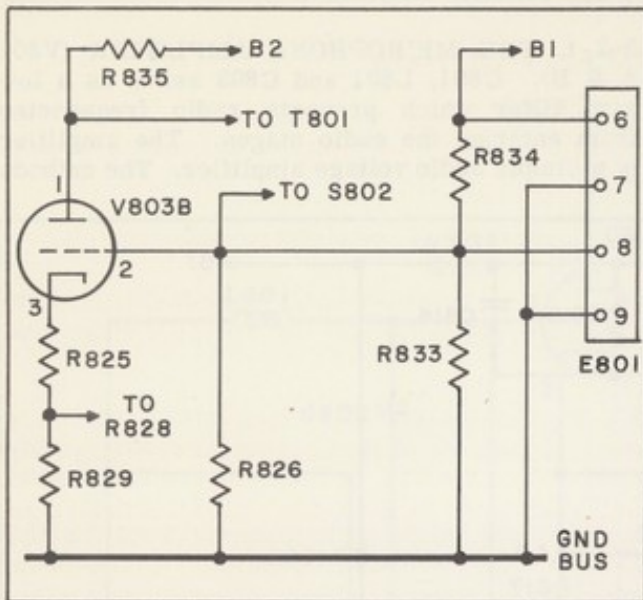

Figure 2-7. Simplified Diagram, Keyer Circuit

resistor R805, of V801B is disconnected from ground by S802C so that this stage will be inoperative in the MCW or SIDETONE mode.

2-2-2. THE LIMITER - OSCILLATOR (V802 A & B). V802A & B is connected as a balanced limiter when the FUNCTION switch, S802, is in the CLIP position. When the selector is in any tone position, V802B is connected as a Colpitts oscillator with three selectable audio frequencies.

2-2-3. THE PHASE INVERTER (V803A) and OUTPUT AMPLIFIER (V804). The audio from the earlier stages is inverted and amplified in these stages to the level necessary to drive the modulator. The output of V804 is coupled through a transformer, T801, which has a 600 ohm center-tapped output winding.

2-2-4. THE KEYER (V803B). The grid is connected to ground by the key in any tone position

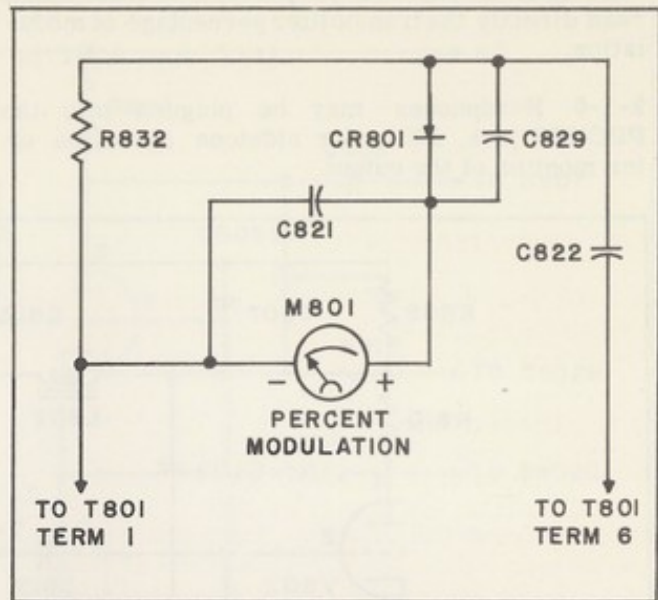

Figure 2-8. Simplified Diagram Metering Circuit

of the FUNCTION switch, S802C, or directly to ground by the switch when in the NORMAL or CLIP positions.

2-2-5. THE METERING CIRCUIT (M801). The audio signal from the output of T801 is rectified and filtered in this circuit to provide meter indication of the output level. The output meter is calibrated in percent modulation.

2-2-6. THE RELAY (K801). This relay provides contacts to remotely control the transmitter plates relay and contacts for receiver muting. The relay is actuated by either the push-to-talk switch on the microphone or the OPERATE-STANDBY switch on the front panel.

2-2-7. THE POWER SUPPLY (V805). The power supply provides the necessary AC filament and DC B+ voltages.

## SECTION III INSTALLATION AND OPERATION

### 3-1. INSTALLATION

3-1-1. The TMC Model RTC, Remote Control Amplifier, has been designed for ease of installation and minimum effort in operation.

### 3-2. UNPACKING

3-2-1. The unit is packed in an individual shipping container, and should be carefully unpacked. Packing material should be examined for loose items before discarding. A close visual inspection should be made to determine any physical damage due to rough handling during shipment. If damage is found notify carrier immediately.

### 3-3. POWER SUPPLY

3-3-1. The unit is designed for operation from 115 volts, 50/60 cycle source, unless specifically ordered for 230 volt 50/60 cycles. The unit is shipped wired for 115 volt AC operation. A simple wiring change in the primary circuit of the power transformer is necessary to change the Model RTC to 230 volt AC operation. See Figure 5-6 (Schematic Diagram). This change is made directly on the power transformer terminal lugs as follows:

1. Remove jumpers between terminals 1 and 2, 3 and 4. Add jumper between terminals 2 and 3.
2. Change the fuse F801 to 1-1/2 amp.

### 3-4. ELECTRICAL CONNECTIONS

3-4-1. Connect power cable (supplied) from J304 to an AC power source of proper voltage and frequency.

3-4-2. The proper electrical connections are made at the rear of the chassis to terminal strip E801. When the RTC is used with the TMC Model GPT-750-1 or GPT-750-2, interconnection of the two units can be made with the TMC CA-274 Remote Control Cable supplied. Connections may also be made by telephone link.

3-4-3. The TMC CA-274 Remote Control Cable is supplied as a loose item. Connect the cable from E801 of the RTC to E501 of the GPT-750-1 or GPT-750-2 as shown in Figure 3-2. When the RTC is used with the GPT-750-1, disconnect the jumper from terminal 8 to terminal 9 of E801 on the RTC. The jumper connection is incorporated in the Remote Control cable CA-274 supplied for use with the GPT-750-2.

3-4-4. When a telephone link is used, make the same connections as CA-274, eliminating the shield and connection between terminal 10 of the RTC and terminal 10 of the transmitter.

3-4-5. Connections may be made to some other transmitter by making appropriate connections to E801 of the RTC. See Figure 3-1.

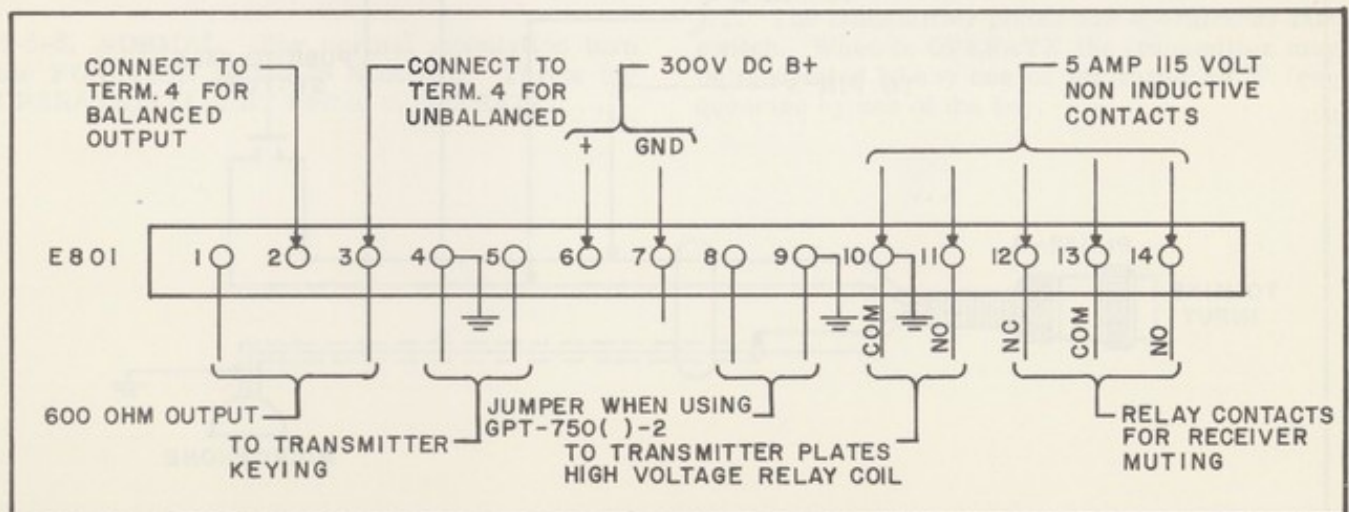

Figure 3-1. Terminal Board Wiring, Model RTC

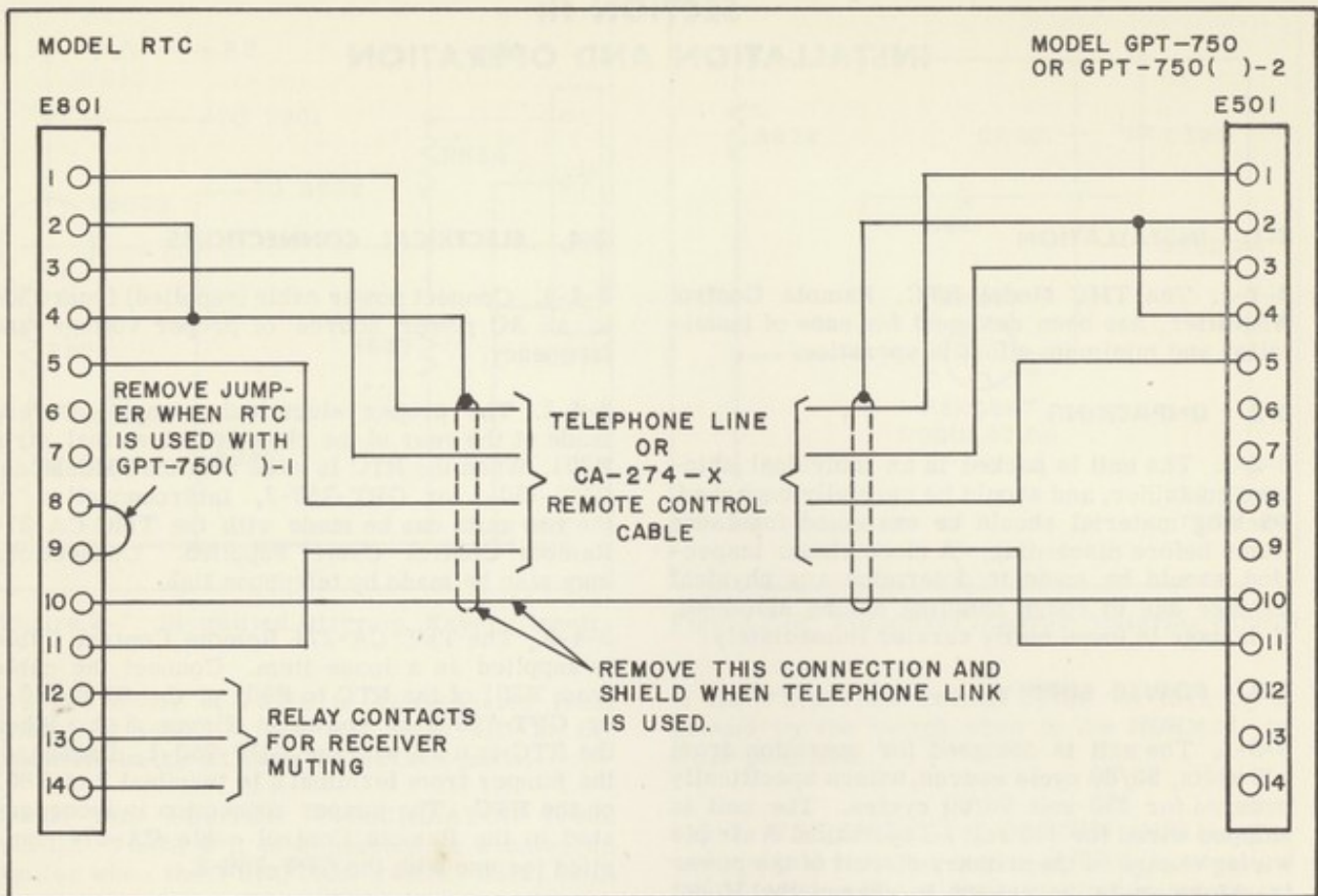

Figure 3-2. Interconnect Diagram, RTC to GPT-750

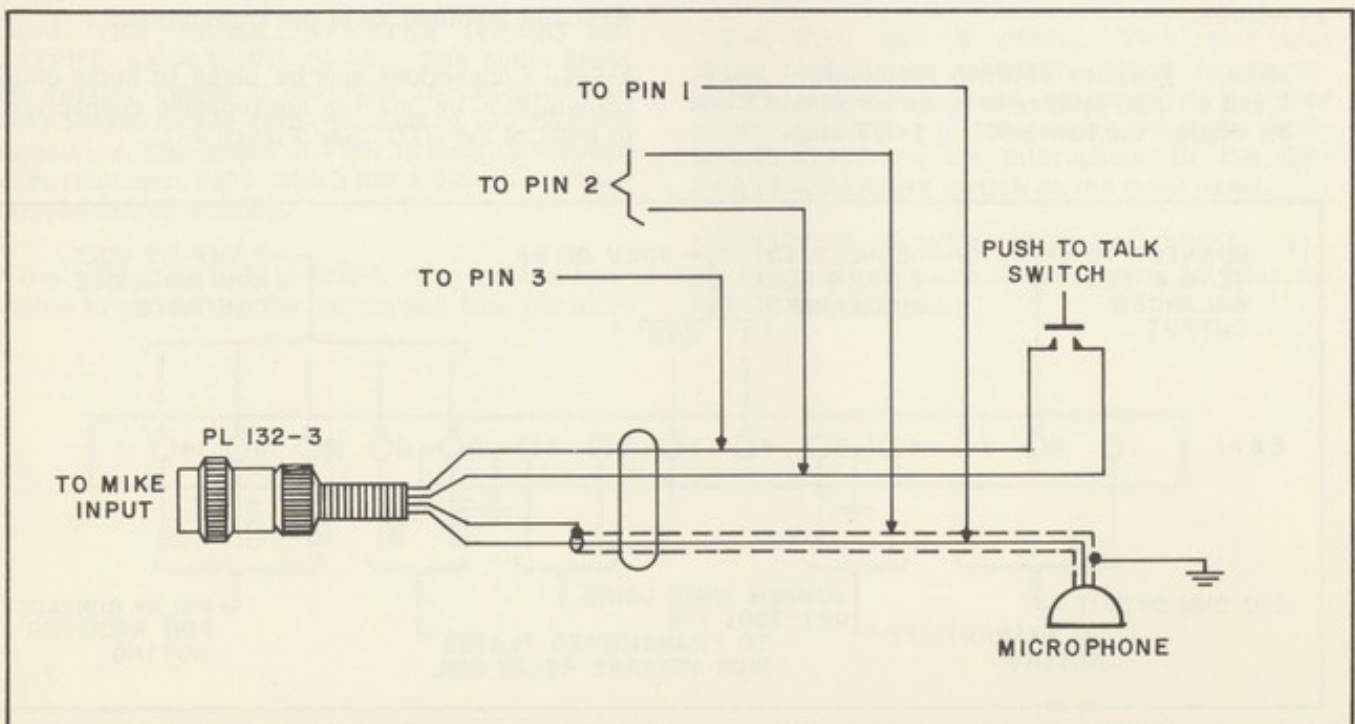

Figure 3-3. Microphone Connections

3-4-6. Connect the mike plug, PL-132-3, supplied as a loose item, to the mike cable. Connect the inner conductor which goes to the mike to pin 1; the outer shield and ground lead of the push-to-talk switch to pin 2; the other lead of push-to-talk switch to pin 3.

### 3-5. OPERATION

3-5-1. CW OPERATION: Plug the key into the jack marked KEY on the front panel. Tune the transmitter for CW operation.

3-5-2. On the GPT-750-1 or GPT-750-2 transmitter, turn the TRANSMITTER PLATES switch to STANDBY/REMOTE and leave the FINAL PLATE switch ON. Transmitter plates may now be controlled from the RTC by means of the OPERATE/STANDBY switch on the RTC front panel.

3-5-3. If side tone (monitoring of keying) is desired, turn the MCW or SIDE TONE switch on the RTC front panel to one of the three side tone frequencies and plug a pair of phones into the PHONES jack. The GAIN control regulates the amplitude of the side tone.

3-5-4. AM OPERATION: Tune the transmitter for AM operation.

3-5-5. On the GPT-750-1 or GPT-750-2 transmitter, return the TRANSMITTER PLATES switch to STANDBY/REMOTE, and leave the FINAL PLATE switch ON. All transmitter plates may now be controlled from the RTC by means of the OPERATE/STANDBY switch on its front panel, or by pressing the push-to-talk switch on the microphone.

3-5-6. NORMAL: For normal modulation turn the FUNCTION switch to NORMAL. Throw the OPERATE/STANDBY switch to OPERATE.

3-5-7. Advance the GAIN control on the RTC clockwise until the meter on the front panel reads 100% modulation on speech peaks.

3-5-8. Advance the GAIN control on the Modulator, TMC Model RTM, (p/o GPT-750), until the Modulator current reaches 300 Ma. on peaks.

3-5-9. The RTC will indicate directly the percentage of modulation which may be varied by the RTC GAIN control. The setting of the GAIN control on the RTM is not further adjusted except for change of transmitter power.

3-5-10. Return the OPERATE/STANDBY switch to STANDBY. The transmitter plates are operated by this switch or by the push-to-talk switch on the mike.

3-5-11. CLIP: For Speech Clip Operation proceed as outlined under normal phone operation except that the FUNCTION switch is rotated to CLIP and the GAIN control is set for 100% modulation indication on the front panel meter on the RTC, after the desired degree of clipping has been obtained by means of the CLIPPER control. The degree of clipping can be monitored by plugging phones into the PHONES jack.

3-5-12. MCW OPERATION: For MCW operation proceed as outlined under normal phone operation except the FUNCTION switch is rotated to the desired tone frequency. Throw the OPERATE/STANDBY switch to OPERATE. Depress the key and set the GAIN control so that the modulation meter indicates 100% modulation. Advance the GAIN CONTROL on the RTM until the RTM current meter reaches 300 ma. Further adjustment of this control is unnecessary unless a change in transmitter power occurs. Release key. Return the RTC OPERATE/STANDBY switch to STANDBY. The transmitter plates are operated by this switch. When in OPERATE the transmitter may be modulated by any one of the three MCW frequencies by use of the key.



## SECTION IV MAINTENANCE

### 4-1. GENERAL

4-1-1. The Model RTC has been designed for long term trouble free duty. Little attention beyond normal maintenance is required. It is recommended that any maintenance to the equipment be performed by a competent technician.

4-1-2. Should normal operating procedure produce unsatisfactory results, a quick check of the power supply will very often determine the cause of the trouble. A pilot light indicates when power is being applied to the unit. If no power is evident, check the fuse on the rear apron. A blown fuse must be replaced with one of equal value. If the fuse blows again the unit should be checked for shorts. The most common cause of operational failure is usually tube failure. Checking the tubes will often save many hours of unnecessary troubleshooting.

### 4-2. OPERATOR'S MAINTENANCE AND PREVENTIVE MAINTENANCE

4-2-1. All components in this unit have been carefully selected to assure maximum efficiency in operation. If the gain should drop and tube failure is suspected, test each tube in a reliable tube tester. The measured characteristics of the tube should be within the manufacturers tolerances (usually  $\pm 20\%$  from tube manual tolerances). No special selection is necessary in the event of tube replacement, but the operator should remember that tubes of the same type will vary slightly in their individual characteristics.

4-2-2. Increased distortion in the RTC when used in the NORMAL or MCW positions may be due to unbalance in the output stage. This may occur when component and tube characteristics change with age. See OUTPUT BALANCE ADJUSTMENT for procedure when this condition is suspected.

4-2-3. Excessive hum may be caused by ground loops. The Model RTC uses a one point grounding

system to avoid ground loops or paths over which hum voltages may occur. All ground connections are made to a common bus, not the chassis. This bus is grounded to the chassis at a point near J801. See that no ground or shielded leads touch the chassis and that no connections be made to the chassis. Ground connections should be made to terminal 4, 7, 9 or 10 on E801.

4-2-4. Failure may occur due to breakdown of capacitors or resistors. Test all AC and DC voltages and investigate any serious discrepancies from voltage chart figures. See Figure 4-1.

4-2-5. In order to prevent failure of the equipment due to corrosion, dust, and other destructive ambient conditions thoroughly inspect the inside of the chassis for signs of dirt, dampness, moulding, charring, or corrosion. This should be done periodically depending upon the severity of the conditions. Correct any defect with cleaning agent of proven quality. When placing the unit in the rack or case, the operator should make certain that all terminal screw connections are tight.

### 4-3. OUTPUT BALANCE ADJUSTMENT

- A. Equipment required:
  - (1). Oscilloscope
  - (2). 600 ohm resistor
- B. Connect terminal 3 to terminal 4 of E801.
- C. Connect the 600 ohm resistor from terminal 1 to terminal 3 on E801.
- D. Connect the oscilloscope to terminal 1 and terminal 3.
- E. Turn the FUNCTION switch to the 500 cycle position.
- F. Turn the GAIN control fully clockwise. The scope should read approximately 5.6 volts peak-to-peak, and the percentage Modulation Meter, M801, should read approximately 100%.
- G. Key the unit at a slow rate, 5 to 10 cps, and adjust the balance control, R828, so that the wave form is centered on the horizontal trace.

Figure 4-1. Voltage Chart, Model RTC

	PIN 1		PIN 2		PIN 3		PIN 4		PIN 5		PIN 6		PIN 7		PIN 8		PIN 9	
	A	B	A	B	A	B	A	B	A	B	A	B	A	B	A	B	A	B
V801 12 AX 7	95	95	0	0	0.62	0.62	3.15 AC		3.15 AC		125	165	0		1.2	3.0	3.15 AC	
V802 12 AT 7	285	175	0	1.5	3	8	3.15 AC		3.15 AC		340	300	0		3	8	3.15 AC	
V803 12 AU 7	215	195	0	0	9.5	8.5	3.15 AC		3.15 AC		295	260	0		20	17	3.15 AC	
V804 12 AT 7	210	190	0	0	3.5	6.1	3.15 AC		3.15 AC		210	190	0		3.5	6.1	3.15 AC	
V805 5Y3			310	310			300 AC				300 AC	300 AC			310	310		

CONDITIONS -

1. TERMINAL 8 & 9 ON E801 JUMPERED.
2. CLIPPER CONTROL FULLY COUNTER-CLOCKWISE.
3. GAIN CONTROL FULLY COUNTER-CLOCKWISE.
4. OPERATE STANDBY SWITCH IN OPERATE POSITION.
5. POWER ON.
6. ALL MEASUREMENTS WITH VTVM.

NOTE -

1. COLUMN A - FUNCTION SWITCH NORMAL OR CLIP.
2. COLUMN B - FUNCTION SWITCH MCW OR SIDETONE.
3. VOLTAGES GIVEN ARE TYPICAL AND MAY VARY AS MUCH AS 20 % .
4. ALL VOLTAGES ARE DC EXCEPT WHERE NOTED. ALL VOLTAGES ARE TAKEN TO GROUND.

## SECTION V ELECTRICAL PARTS LIST

SYM.	DESCRIPTION	FUNCTION	TMC PART NO.
C801	CAPACITOR, fixed: mica; 270 mmfd., ±10%, 500 wvdc; char. B.	P/O R.F. Filter, V801	CM20B271K
C802	CAPACITOR, fixed: mica; 270 mmfd., ±10%, 500 wvdc; char. B.	P/O R.F. Filter, V801	CM20B271K
C803 A,B	CAPACITOR, fixed: dry electrolytic; polarized; plug in; 20 mfd., 450 wvdc; char. E.	Cathode Bypass Cap., V801	CE52E200R
C804	CAPACITOR, fixed: ceramic; .01 mfd., +80-20%, 500 wvdc; disc type.	Coupling Cap., V801	CC-100-16
C805	CAPACITOR, fixed: mica; .01 mfd., ±5%, 300 wvdc; char. C.	Coupling Cap., V801	CM35C103J
C806	CAPACITOR, fixed: mica; 1000 mmfd., ±5%, 500 wvdc; char. B.	Coupling Cap., V802	CM20B102J
C807	CAPACITOR, fixed: mica; .01 mfd., ±5%, 300 wvdc; char. C. (Same as C805)	P/O Low Pass Filter, V802	CM35C103J
C808	CAPACITOR, fixed: moulded plastic; .02 mfd, +40-20%, 600 wvdc.	P/O Oscillator Plate Tank, V802	CN-100-17
C809	CAPACITOR, fixed: moulded plastic; .05 mfd, +40-20%, 400 wvdc.	P/O Oscillator Plate Tank, V802	CN-100-3
C810	CAPACITOR, fixed: mylar dielectric; .2 mfd., ±10%, 400 wvdc.	P/O Oscillator Plate Tank, V802	CN104E2003K
C811	CAPACITOR, fixed: moulded plastic; .02 mfd, +40-20%, 600 wvdc. (Same as C808)	P/O Oscillator Plate Tank, V802	CN-100-17
C812	CAPACITOR, fixed: moulded plastic; .05 mfd, +40-20%, 400 wvdc. (Same as C809)	P/O Oscillator Plate Tank, V802	CN-100-3
C813	CAPACITOR, fixed: mylar dielectric; .2 mfd, ±10%, 400 wvdc. (Same as C810)	P/O Oscillator Plate Tank, V802	CN104E2003K
C814	CAPACITOR, fixed: mica; .01 mfd, ±5%, 300 wvdc; char. C. (Same as C805)	P/O Low Pass Filter, V802	CM35C103J

SYM.	DESCRIPTION	FUNCTION	TMC PART NO.
C815	CAPACITOR, fixed: mica; .01 mfd, ±5%, 300 wvdc; char. C. (Same as C805)	Feedback Cap., V802	CM35C103J
C816	CAPACITOR, fixed: moulded plastic; .1 mfd, +40-10%, 400 wvdc.	Coupling Cap., V803A	CN-100-4
C817	CAPACITOR, fixed: mica; .01 mfd, ±5%, 300 wvdc; char. C. (Same as C805)	Coupling Cap., V803A	CM35C103J
C818	CAPACITOR, fixed: mica; .01 mfd, ±5%, 300 wvdc; char. C.	Coupling Cap., V803A	CM35C103J
C819	Not Used.		
C820	Not Used.		
C821	CAPACITOR, fixed: mica; .01 mfd., ±5%, 300 wvdc; char. C. (Same as C805)	Meter Bypass Cap., M801	CM35C103J
C822	CAPACITOR, fixed: moulded plastic; .1 mfd., +40-20%, 400 wvdc. (Same as C816)	Meter Coupling Capacitor	CN-100-4
C823	CAPACITOR, fixed: mica; .01 mfd., ±5%, 300 wvdc; char. C. (Same as C805)	Line Bypass Capacitor, V805	CM35C103J
C824	CAPACITOR, fixed: mica; .01 mfd., ±5%, 300 wvdc; char. C. (Same as C805)	Line Bypass Capacitor, V805	CM35C103J
C825 A,B	CAPACITOR, fixed: dry electrolytic; polarized; plug in; 20 mfd, 450 wvdc; char. E. (Same as C803)	Filter Cap., V805	CE52E200R
C826 A,B	CAPACITOR, fixed: dry electrolytic; polarized; plug in; 20 mfd., 450 wvdc; char. E. (Same as C803)	Filter Cap., V805	CE52E200R
C827	Not Used.		
C828	CAPACITOR, fixed: paper; .5 mfd., ±10%, 600 wvdc; oil filled, impregnated, hermetically sealed metal case.	Filter Cap., V805	CP53B1EF504K
C829	CAPACITOR, fixed: mica; .01 mfd., ±5%, 300 wvdc; char. C. (Same as C805)	RF Bypass Cap., CR801	CM35C103J
C830	Not Used.		
C831	Not Used.		

SYM.	DESCRIPTION	FUNCTION	TMC PART NO.
C832	CAPACITOR, fixed: ceramic; 1000 mmfd., ±200 mmfd., 500 wvdc; disc type.	R.F. Bypass Cap., E801	CC-100-9
C833	CAPACITOR, fixed: ceramic; 1000 mmfd., ±200 mmfd., 500 wvdc; disc type. (Same as C832)	R.F. Bypass Cap., E801	CC-100-9
C834	CAPACITOR, fixed: ceramic; 1000 mmfd., ±200 mmfd., 500 wvdc; disc type. (Same as C832)	R.F. Bypass Cap., E801	CC-100-9
C835	CAPACITOR, fixed: ceramic; 1000 mmfd., ±200 mmfd., 500 wvdc. (Same as C832)	R.F. Bypass Cap., E801	CC-100-9
C836	CAPACITOR, fixed: ceramic; 1000 mmfd., ±200 mmfd., 500 wvdc; disc type. (Same as C832)	R.F. Bypass Cap., E801	CC-100-9
C837	CAPACITOR, fixed: ceramic; 1000 mmfd., ±200 mmfd., 500 wvdc; disc type. (Same as C832)	R.F. Bypass Cap., E801	CC-100-9
C838	CAPACITOR, fixed: ceramic; 1000 mmfd., ±200 mmfd., 500 wvdc; disc type. (Same as C832)	R.F. Bypass Cap., E801	CC-100-9
C839	CAPACITOR, fixed: ceramic; 1000 mmfd., ±200 mmfd., 500 wvdc; disc type. (Same as C832)	R.F. Bypass Cap., E801	CC-100-9
C840	CAPACITOR, fixed: moulded plastic; .1 ufd., +40-10%, 400 wvdc. (Same as C816)	Switch Bypass	CN-100-4
CR801	CRYSTAL UNIT, rectifying; germanium.	Meter Rectifier	1N-34
CR802	CRYSTAL UNIT, rectifying; germanium.	D.C. Blocking	1N-39
E801	BOARD, terminal: barrier type; fourteen 6-32 x 1/4 in. binding head machine screws.	Output Terminal Strip	TM-100-14
F801	FUSE, cartridge: 3 amp.	Input Power Fuse	FU-100-3
I801	LAMP, incandescent: 6-8 V.; .250 amp.; bulb T-3 1/4 clear.	Power Indicator	BI-101-44
J801	CONNECTOR, receptacle: female; three contacts; mtg. dim. 27/32 in. dia. cutout.	Mike Input Connector	JJ-133-3
J802	JACK, open circuit: telephone.	Keying Input Jack	JJ-034

SYM.	DESCRIPTION	FUNCTION	TMC PART NO.
J803	JACK, open circuit : telephone. (Same as J802)	Phone Output Jack	JJ-034
J804	CONNECTOR, receptacle: male; recessed; locking type; 2 contacts; 10 amps at 250 volts; 15 amps at 125 volts.	AC Power Input Connector	JJ-100
K801	RELAY, stud mounted: Break-Make type; D.C. contacts; 5 amps., 115 volts; non-inductive.	Plate Power Relay	RL-116-DC-2C-120
L801	CHOKE, RF: 765 microhenries, $\pm 20\%$ ; 100 ma. max. current.	P/O R.F. Filter, V801	CL-100-5
L802	CHOKE, RF: 820 millihenries, $\pm 2\%$ ; Q=55, $\pm 10\%$ ; D.C. resistance 70-80 ohms.	P/O Oscillator Plate Tank & Low Pass Filter, V802	CL-121
L803	REACTOR, filter: 50 henries; D.C. resistance approx. 800 ohms; 30 ma D.C.; insulated for 1500 V in accord- ance with MIL-T-27, GR. 1, CL. A, FAM.03.	P.S. Filter Choke, V805	TF-166
L804	REACTOR, filter: 50 henries; D.C. resistance approx. 800 ohms; 30 ma D.C.; insulated for 1500 V in accord- ance with MIL-T-27, GR.1, CL. A, FAM.03. (Same as L803)	P.S. Filter Choke, V805	TF-166
M801	METER, microamp: 0-50 microamps D.C.; mtg. dim. one 2 3/4 in. dia. hole w/four 1/8 in. dia. holes on 2 1/4 in. mtg. centers.	Output Level Meter	MR-111-27-50
P801	CONNECTOR, plug: male; three contacts. (Supplied as a loose item)	Mike Input Plug	PL-132-3
R801	RESISTOR, fixed: composition; 470,000 ohms, $\pm 10\%$ , 1/2 watt.	Grid Res., V801	RC20GF474K
R802	RESISTOR, fixed: composition; 1000 ohms, $\pm 10\%$ , 1/2 watt.	Cathode Res., V801	RC20GF102K
R803	RESISTOR, fixed: composition; 100,000 ohms, $\pm 10\%$ , 1/2 watt.	Plate Res., V801	RC20GF104K
R804	RESISTOR, fixed: composition; 100,000 ohms, $\pm 10\%$ , 1/2 watt.	Plate Res., V801	RC20GF104K
R805	RESISTOR, fixed: composition; 3300 ohms, $\pm 10\%$ , 1/2 watt.	Cathode Res., V801	RC20GF332K
R806	RESISTOR, fixed: composition; 470,000 ohms, $\pm 10\%$ , 1/2 watt. (Same as R801)	Grid Res., V801	RC20GF474K

SYM.	DESCRIPTION	FUNCTION	TMC PART NO.
R807	RESISTOR, variable: composition; 500,000 ohms, linear, $\pm 20\%$ , 2 watt.	Clip Control Res., V802	RV4ATRD504B
R808	RESISTOR, fixed: composition; 5600 ohms, $\pm 10\%$ , 1/2 watt.	Cathode Res., V802	RC20GF562K
R809	RESISTOR, fixed: composition; 6800 ohms, $\pm 10\%$ , 1/2 watt.	P/O Plate Volt. Div., V802	RC20GF682K
R810	RESISTOR, fixed: composition; 82,000 ohms, $\pm 10\%$ , 1 watt.	Plate Res., V802	RC30GF823K
R811	RESISTOR, fixed: composition; 270 ohms, $\pm 10\%$ , 1/2 watt.	Cathode Res., V802	RC20GF271K
R812	RESISTOR, fixed: composition; 220,000 ohms, $\pm 10\%$ , 1/2 watt.	Volt. Limiting Res., V801	RC20GF224K
R813	RESISTOR, fixed: composition; 470,000 ohms, $\pm 10\%$ , 1/2 watt. (Same as R801)	Grid Res., V802	RC20GF474K
R814	RESISTOR, fixed: composition; 6800 ohms, $\pm 10\%$ , 1/2 watt. (Same as R809)	P/O Low Pass Filter, V802	RC20GF682K
R815	RESISTOR, fixed: composition; 33,000 ohms, $\pm 5\%$ , 1/2 watt.	Volt. Limiting Res., V802	RC20GF333J
R816	RESISTOR, fixed: composition; 33,000 ohms, $\pm 5\%$ , 1/2 watt. (Same as R815)	Volt. Limiting Res., V802	RC20GF333J
R817	RESISTOR, fixed: composition; 47,000 ohms, $\pm 10\%$ , 1/2 watt.	Volt. Limiting Res., V802	RC20GF473K
R818	RESISTOR, fixed: composition; 180,000 ohms, $\pm 10\%$ , 1/2 watt.	Volt. Limiting Res., V802	RC20GF184K
R819	RESISTOR, fixed: composition; 15,000 ohms, $\pm 10\%$ , 1/2 watt.	Volt. Limiting Res., V802	RC20GF153K
R820	RESISTOR, variable: composition; 50,000 ohms, linear, $\pm 20\%$ , 2 watts.	Gain Control Res., V803	RV4ATRD503B
R821	RESISTOR, fixed: composition; 47,000 ohms, $\pm 10\%$ , 1/2 watt. (Same as R817)	Plate Res., V803	RC20GF473K
R822	RESISTOR, fixed: composition; 47,000 ohms, $\pm 10\%$ , 1/2 watt. (Same as R817)	Cathode Res., V803	RC20GF473K
R823	RESISTOR, fixed: composition; 1 megohm, $\pm 10\%$ , 1/2 watt.	Grid Res., V804	RC20GF105K

SYM.	DESCRIPTION	FUNCTION	TMC PART NO.
R824	RESISTOR, fixed: composition; 1 megohm, $\pm 10\%$ , 1/2 watt. (Same as R823)	Grid Res., V804	RC20GF105K
R825	RESISTOR, fixed: composition; 1200 ohms, $\pm 10\%$ , 1 watt.	Cathode Res., V803	RC30GF122K
R826	RESISTOR, fixed: composition; 470,000 ohms, $\pm 10\%$ , 1/2 watt. (Same as R801)	Grid Res., V803	RC20GF474K
R827	RESISTOR, fixed: composition; 3900 ohms, $\pm 10\%$ , 2 watts.	P/O Filter, V805	RC42GF392K
R828	RESISTOR, variable: composition; 500 ohms, linear, $\pm 20\%$ , 2 watts.	Balance Control Res., V804	RV4ATXD501B
R829	RESISTOR, fixed: composition; 560 ohms, $\pm 10\%$ , 1/2 watt.	Cathode Res., V803	RC20GF561K
R830	RESISTOR, fixed: composition; 100,000 ohms, $\pm 10\%$ , 1/2 watt. (Same as R803)	Volt. Limiting Res., J801	RC20GF104K
R831	RESISTOR, fixed: wire wound; 15,000 ohms, 20 ma; 10 watts.	Current Limiting Res., K801	RW-109-36
R832	RESISTOR, fixed: composition; 39,000 ohms, $\pm 5\%$ , 1/2 watt.	Rectifier Load Res., CR801	RC20 GF393J
R833	RESISTOR, fixed: composition; 150,000 ohms, $\pm 10\%$ , 1/2 watt.	P/O Volt. Div., E801	RC20GF154K
R834	RESISTOR, fixed: composition; 470,000 ohms, $\pm 10\%$ , 1/2 watt. (Same as R801)	P/O Volt. Div., E801	RC20GF474K
R835	RESISTOR, fixed: composition; 10,000 ohms, $\pm 10\%$ , 2 watts.	Plate Res., V803	RC42GF103K
R836	RESISTOR, fixed: composition; 220,000 ohms, $\pm 10\%$ , 2 watts.	P/O Filter, V805	RC42GF224K
R837	RESISTOR, fixed: composition; 470,000 ohms, $\pm 10\%$ , 1/2 watt. (Same as R801)	Grid Res., V804	RC20GF474K
S801	SWITCH, toggle: DPST, 1 amp, 250 V.	Operate Standby Switch	ST22K
S802	SWITCH, rotary: 3 sections; 5 positions; insulation bakelite; contacts and wipers silver plated; 1/4 in. drive shaft, 7/8 in. long.	Function Switch	SW-177
S803	SWITCH, toggle: DPST, 1 amp., 250 V. (Same as S801)	ON/OFF Switch	ST22K

SYM.	DESCRIPTION	FUNCTION	TMC PART NO.
T801	TRANSFORMER, audio: primary, 30,000 ohms impedance split; secondary, 50/200 ohms, 125/500 ohms impedance; $\pm 2$ db response, 30-20,000 cps.	Plate Output Transformer V804	TF-154
T802	TRANSFORMER, power: primary 110/220 volt, 50/60 cycle, single phase; sec. No. 1 = 600 V., .070 A., center tapped; sec. No. 2 = 6.3 V, 3 A., center tapped; sec. No. 3 = 5 V., 2 A., sec. No. 4 = 6.3 V., 1.2 A; in accordance with MIL-T-27, GR .1, CL. A, FAM.03.	Power Input Transformer, V805	TF-106
V801	TUBE, electron: High-Mu duo-triode; 9 pin miniature.	Input Amplifier	12AX7
V802	TUBE, electron: duo-triode; 9 pin miniature.	Limiter Oscillator	12AT7
V803	TUBE, electron: medium-Mu duo-triode; 9 pin miniature.	Inverter, Keyer	12AU7
V804	TUBE, electron: duo-triode; 9 pin miniature. (Same as V802)	Output Amplifier	12AT7
V805	TUBE, electron: full-wave rectifier; 8 pin octal.	Full Wave Rectifier	5Y3G
W801	CABLE, power: consists of one moulded non-polarized male plug; six feet of 16/30 SJ cable; and one phenolic twist lock connector, female. (PL-100)	Power Cable	CA-103
W802	CABLE ASSEMBLY, electrical: RTC-GPT-750 interconnect; consists of two fanning strips, TM-105-12-AR, and TM-105-12-AL; one 6 conductor cable, 12 ft. lg., and associated hardware. (Supplied only on customers request)	Remote Control Cable	CA-274-12
XC803	SOCKET, octal: one piece saddle mtg. w/4 tinned ground lugs.	C803 Socket	TS-101-P01
XC825	SOCKET, octal: one piece saddle mtg. w/4 tinned ground lugs. (Same as XC803)	C825 Socket	TS-101-P01
XC826	SOCKET, octal: one piece saddle mtg. w/4 tinned ground lugs. (Same as XC803)	C826 Socket	TS-101-P01
XF801	HOLDER, fuse: stationary end terminal.	F801 Holder	FH-100-2

SYM.	DESCRIPTION	FUNCTION	TMC PART NO.
XI801	SOCKET, lens: red; for miniature bayonet base, using T-3-1/4 bulb.	I801 Socket	TS-106-1
XV801	SOCKET, tube: 9 pin miniature.	V801 Socket	TS-103-P01
XV802	SOCKET, tube: 9 pin miniature. (Same as XV801)	V802 Socket	TS-103-P01
XV803	SOCKET, tube: 9 pin miniature. (Same as XV801)	V803 Socket	TS-103-P01
XV804	SOCKET, tube: 9 pin miniature. (Same as XV801)	V804 Socket	TS-103-P01
XV805	SOCKET, tube: octal; one piece saddle mtg. w/4 tinned ground lugs. (Same as XC803)	V805 Socket	TS-101-P01

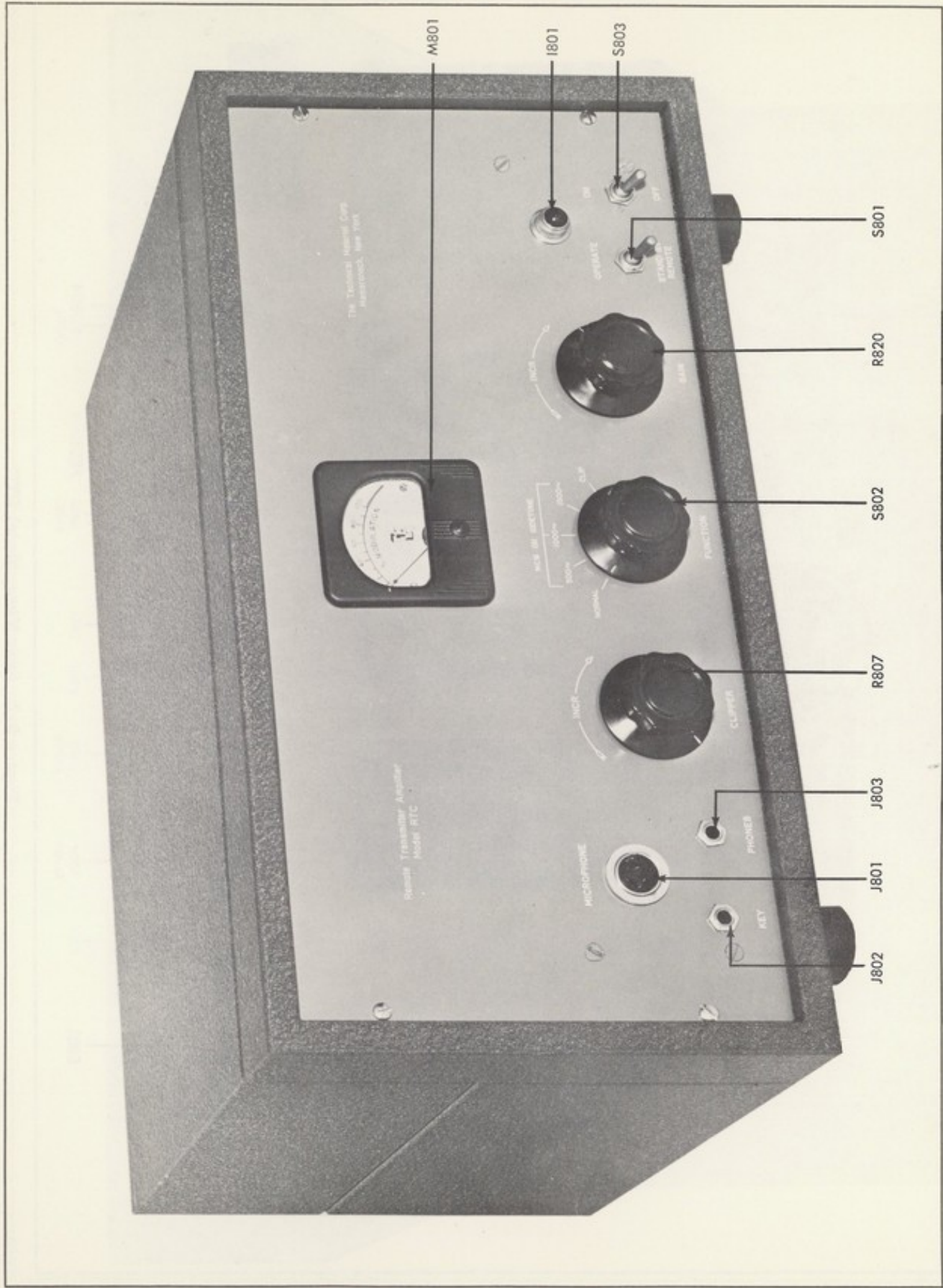

Figure 5-1. Front View, Model RTC

PH-475

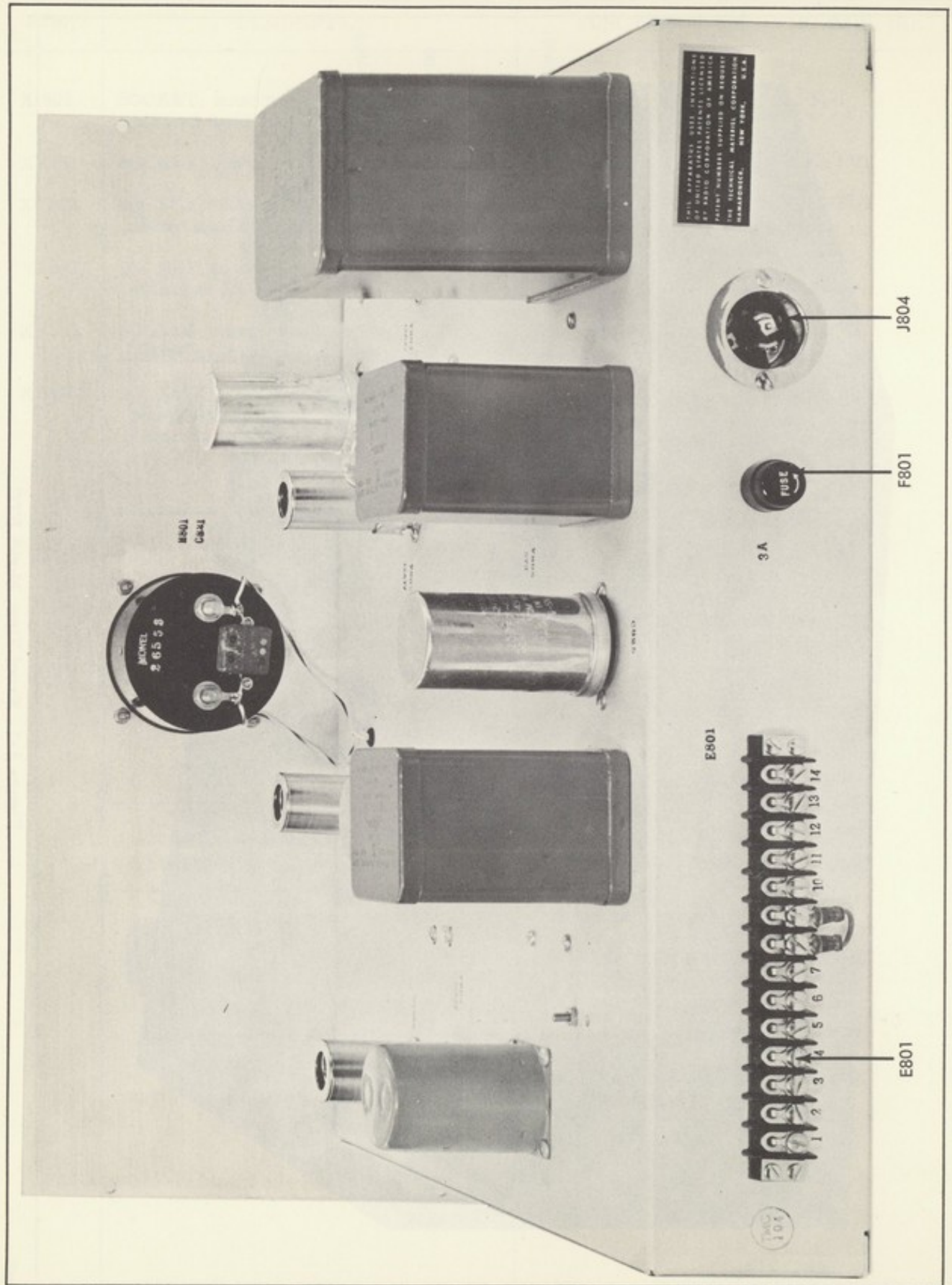

Figure 5-2. Rear View, Model RTC

PH-531

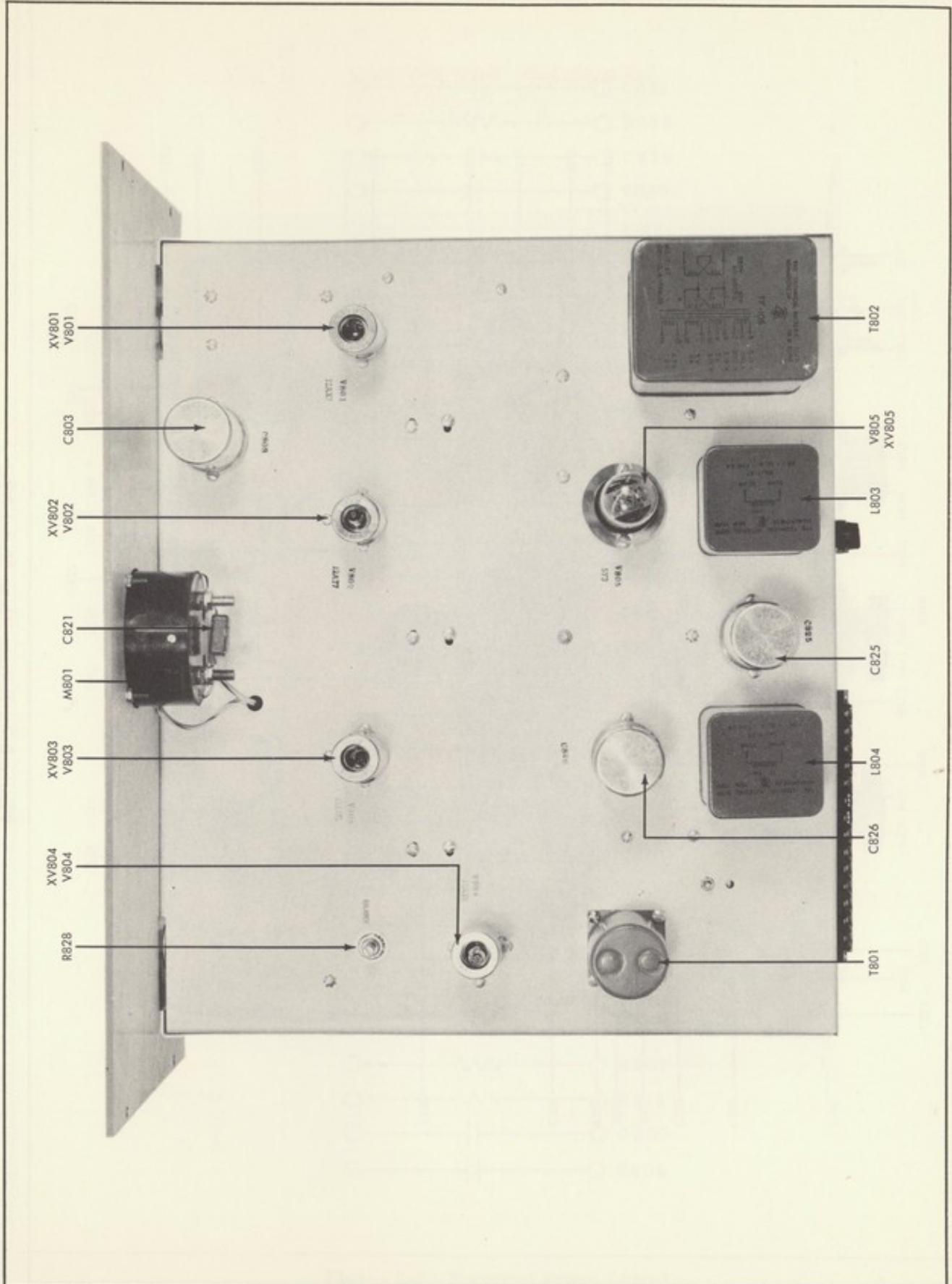

Figure 5-3. Top View, Model RTC

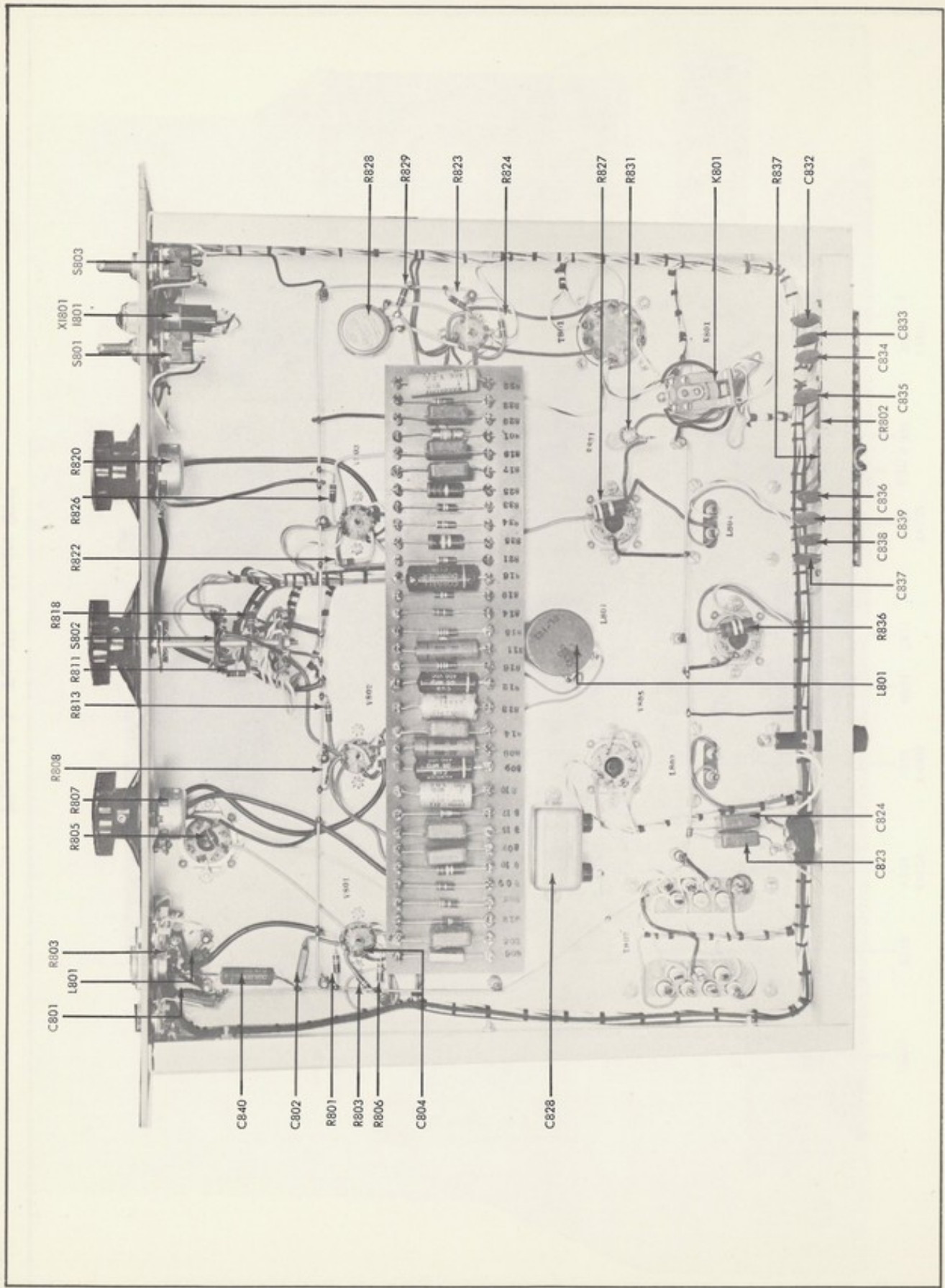

Figure 5-4. Bottom View, Model RTC

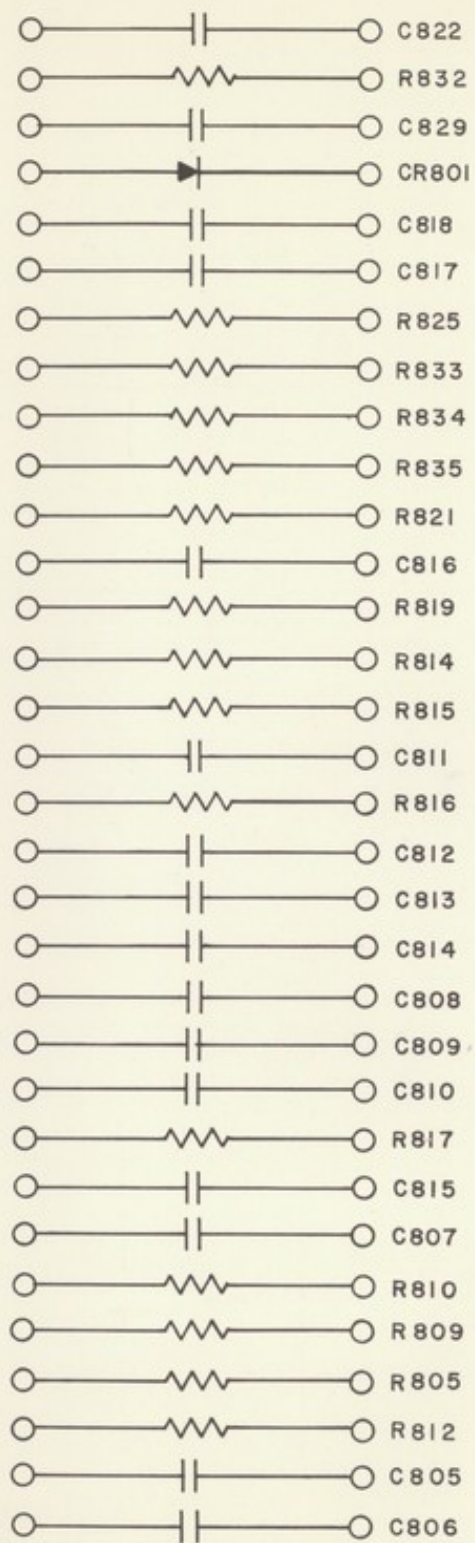
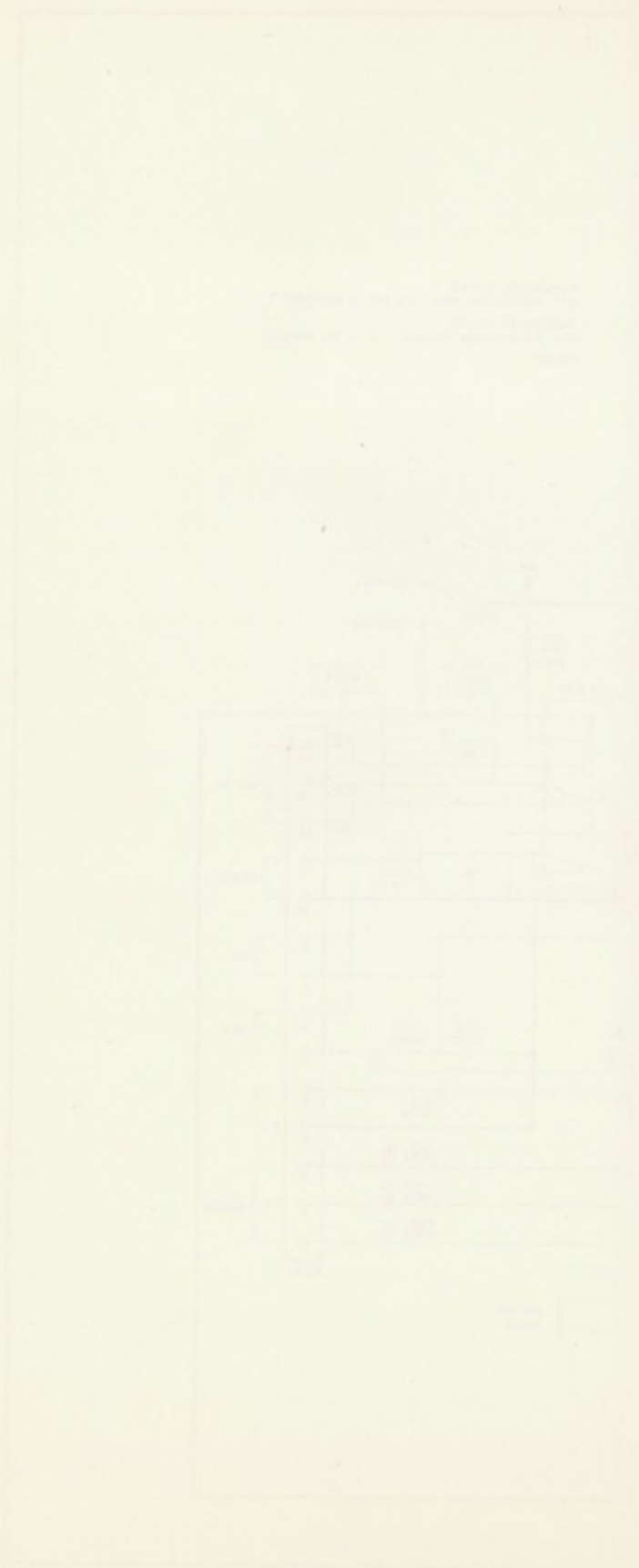

Figure 5-5. Terminal Board Layout

1950

THE UNIVERSITY OF CHICAGO



UNIT TEST REPORT

Q.No	Answer
1	
2	
3	
4	
5	
6	
7	
8	
9	
10	
11	
12	
13	
14	
15	
16	
17	
18	
19	
20	
21	
22	
23	
24	
25	
26	
27	
28	
29	
30	
31	
32	
33	
34	
35	
36	
37	
38	
39	
40	
41	
42	
43	
44	
45	
46	
47	
48	
49	
50	
51	
52	
53	
54	
55	
56	
57	
58	
59	
60	
61	
62	
63	
64	
65	
66	
67	
68	
69	
70	
71	
72	
73	
74	
75	
76	
77	
78	
79	
80	
81	
82	
83	
84	
85	
86	
87	
88	
89	
90	
91	
92	
93	
94	
95	
96	
97	
98	
99	
100	







