

TECHNICAL MANUAL

FOR

SIDEBAND MULTI-CHANNEL EXCITER

MODEL SME()-5

PUBLICATION NUMBER

ISSUE DATE

22 NOV. 1973

THE TECHNICAL MATERIEL CORPORATION

CABLE: TEPEI

700 FENIMORE ROAD, MAMARONECK, NY 10543 U.S.A.

TLX: 137-358

TEL: 914-698-4800

TWX: 710-566-1100

TMC (CANADA) LIMITED

TMC INTERNATIONAL

RR No. 5, Ottawa K1G 3N3 Ontario CANADA

TEL. 613-521-2050

TLX: 053-4146

NOTICE

THE CONTENTS AND INFORMATION CONTAINED IN THIS INSTRUCTION MANUAL IS PROPRIETARY TO THE TECHNICAL MATERIEL CORPORATION TO BE USED AS A GUIDE TO THE OPERATION AND MAINTENANCE OF THE EQUIPMENT FOR WHICH THE MANUAL IS ISSUED AND MAY NOT BE DUPLICATED EITHER IN WHOLE OR IN PART BY ANY MEANS WHATSOEVER WITHOUT THE WRITTEN CONSENT OF THE TECHNICAL MATERIEL CORPORATION.

RECORD OF REVISIONS

NO.	ISSUED	DESCRIPTION	ENTERED	BY
001				
002				
003				
004				
005				
006				
007				
008				
009				
010				

NOTE: Please file Technical Newsletters at back of manual for permanent record.

January 1975

SIDEBAND MULTI-CHANNEL EXCITER

Model SME(R)-5

Automated/Remote

1. INTRODUCTION

When the SME-5 exciter is used in a automated/remote controlled transmitter, the unit is modified. A printed circuit program board and associated wiring are added and two additional connections are made to J120. The exciter is then described as a Model SME(R)-5. The technical manual for the SME-5 Sideband Multi-Channel Exciter will apply to the Model SME(R)-5 when the material in this addendum is incorporated. The wiring change for the addition of the program board is delineated on the schematic diagram (figure 7-1) included in the manual.

2. PROGRAM BOARD

With the CHANNEL select switch (S4, Fig. 7-1) in the REMOTE position, 24vdc is routed to the Extended Mode and Channel Select board All (Fig. 7-14). Here it actuates the appropriate relay when a particular channel is selected on the remote control. A 24vdc signal is routed through the closed contacts of the relay to the added program board (A5615). The program board is so wired that the 24vdc

January 1975

signal will actuate the band switches in the associated equipment properly positioning them to accommodate the frequency of the rf signal being generated on the specific channel.

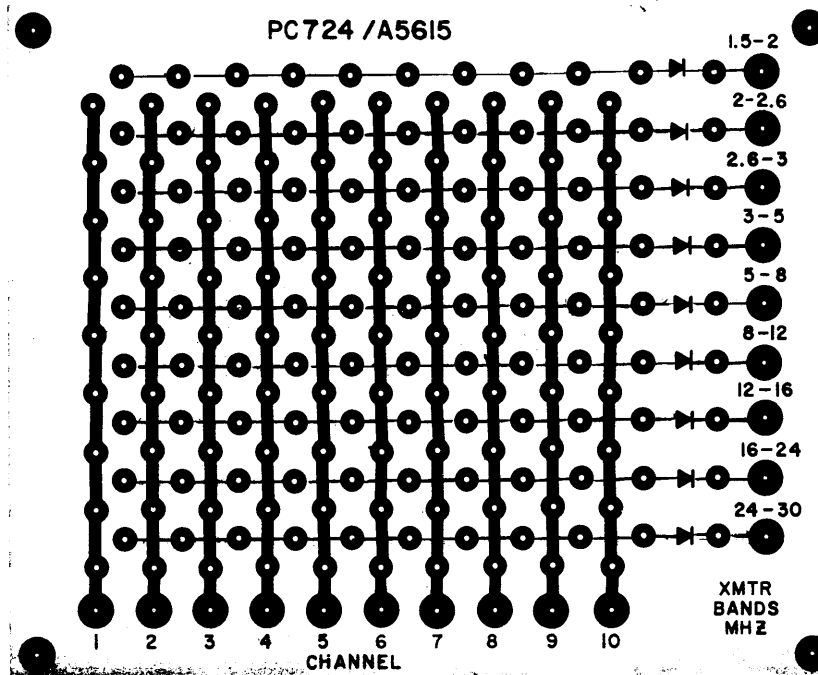

Figure 1

A5615 REMOTE PROGRAM ASSEMBLY		
REF SYMBOL	DESCRIPTION	TMC P/N
CR1 thru CR19	Semiconductor, Device, Diode	1N645

January 1975

The program board (A5615) is shown in addendum figure 1. The fine line connections in the illustration are on the reverse side of the board. From the illustration it will be seen that by strategic placement of jumper diodes from the vertical input terminal strips to the horizontal output terminal strips the bandswitch signal may be directed to the correct band for each channel frequency. The program board is factory wired to accommodate the frequencies specified by the customer.

3. ADDITIONAL CONNECTION TO J120

Two wiring changes have been made. The low side of the "tune relay" (K2, Fig. 7-1) has been connected to pin J of jack J120. This is routed through the transmitter harness to the associated equipment which provides a ground signal during the tune cycle thus actuating the relay. When the tune cycle is complete, the ground is removed, de-actuating the relay.

Pin J of jack J120, is also connected through diode CR18 to terminal 10 on the coil of the push-to-talk relay, K1. This connection defeats the push-to-talk control circuit during the tune cycle and assures that the tubes of the associated amplifiers are switched "on" during this period. Since the push-to-talk relay, K1, is energized, the remote indications are the same as if the push-to-talk switch on the microphone had been operated.

January 1975

When the PTT relay (K1, Fig. 7-1) is actuated by the PTT switch on the microphone, a ground signal is routed by the other additional connection to pin H of jack J120. This signal is routed through the transmitter harness to the associated equipment to provide a "read-back" indication of push-to-talk operation at the remote station.

TABLE OF CONTENTS

<u>Paragraph</u>	<u>Page</u>
SECTION 1 - GENERAL INFORMATION	
1.1 Functional Description	1-2
1.2 Physical Description	1-4
1.3 Technical Specifications	1-5
SECTION 2 - INSTALLATION	
2.1 Unpacking and Handling	2-1
2.2 Power Requirements	2-1
2.3 Mechanical Installation	2-1
2.4 Electrical Installation	2-1
2.5 Performance Check	2-4
SECTION 3 - OPERATOR'S SECTION	
3.1 Controls & Indicators	3-1
3.2 Operating Procedures	3-2
SECTION 4 - PRINCIPLES OF OPERATION	
4.1 General	4-1
4.2 Functional Block Description of SME-5	4-1
4.3 Power Supply Section	4-4
4.4 Audio Inputs and Circuits	4-5
4.5 IF Circuits A9	4-7
4.6 Mixer Doubler A13	4-7
4.7 HF Oven Oscillator A12	4-8
4.8 RF Amplifiers A14	4-10
4.9 Wideband Amplifier A15	4-10
4.10 Frequency Shift Keyer (FSK) A1	4-10
4.11 Extended Line Select A4/A5	4-13
4.12 Extended Mode & Channel Select	4-14
4.13 Automatic Tune	4-14
SECTION 5 - MAINTENANCE	
5.1 Preventive Maintenance	5-1
5.2 Troubleshooting	5-1
5.3 Repair	5-4
5.4 Tuning Procedure for Changing Frequencies	5-4
5.5 Alignment Procedure	5-5
SECTION 6 - PARTS LIST	
6.1 Introduction	6-1
SECTION 7 - SCHEMATIC DIAGRAM	

LIST OF ILLUSTRATIONS

<u>Figure</u>		<u>Page</u>
SECTION 1 - GENERAL INFORMATION		
1-1	Multichannel SSB Exciter SME-5	1-1
SECTION 2 - INSTALLATION		
2-1	SME-5 Rear Panel	2-2
2-2	SME-5 Front Panel	2-5
SECTION 4 PRINCIPLES OF OPERATION		
4-1	SME-5 Functional Block Diagram	4-3
4-2	Mixer/Doubler Simplified Schematic	4-9
4-3	Block Diagram FSK Keyer	4-11
SECTION 5 - MAINTENANCE		
5-1	SME-5 Top Cover Removed	5-10
5-2	FSK Board A1 Parts Location	5-11
5-3	VOX/ANTI-VOX Board A3 Parts Location	5-12
5-4	IF Board A9 Parts Location	5-13
5-5	Regulator Board A10 Parts Location	5-14
5-6	Extended Mode and Channel Select Board All Parts Location	5-15
5-7	HF Oven Oscillator Board A12 Parts Location	5-16
5-8	Oven Control Board A12A1 Parts Location	5-17
5-9	Mixer Doubler Board A13 Parts Location	5-18
5-10	RF Amplifier Board A14 Parts Location	5-19
5-11	Wideband Amplifier Board A15 Parts Location	5-20
5-12	AF Amplifier and Oscillator Board A20 Parts Location	5-21
SECTION 7 - SCHEMATIC DIAGRAMS		
7-1	Main Schematic SME-5	7-2
7-2	Power Supply, A10	7-3
7-3	AF Amplifier and Oscillator A20	7-4
7-4	Metering Board A7	7-5
7-5	VOX/ANTI-VOX A3	7-6
7-6	IF Board A9	7-7
7-7	Mixer Doubler A13	7-8
7-8	HF Oven Oscillator A12	7-9
7-9	Oven Control Board A12A1	7-10
7-10	RF Amplifier A14	7-11
7-11	Wideband Amplifier A15	7-12
7-12	Frequency Shift Keyer A1	7-13
7-13	Extended Line Select A4/A5	7-14
7-14	Extended Mode and Channel Select A11	7-15

LIST OF TABLES

Table

SECTION 1 - GENERAL INFORMATION

1-1	RF Board Frequency Ranges	1-3
1-2	Loose Items Supplied with the SME-5	1-4

SECTION 2 - INSTALLATION

2-1	Rear Panel Connections	2-1
-----	------------------------	-----

SECTION 3 - OPERATOR'S SECTION

3-1	SME-5 Controls and Indicators	3-1
-----	-------------------------------	-----

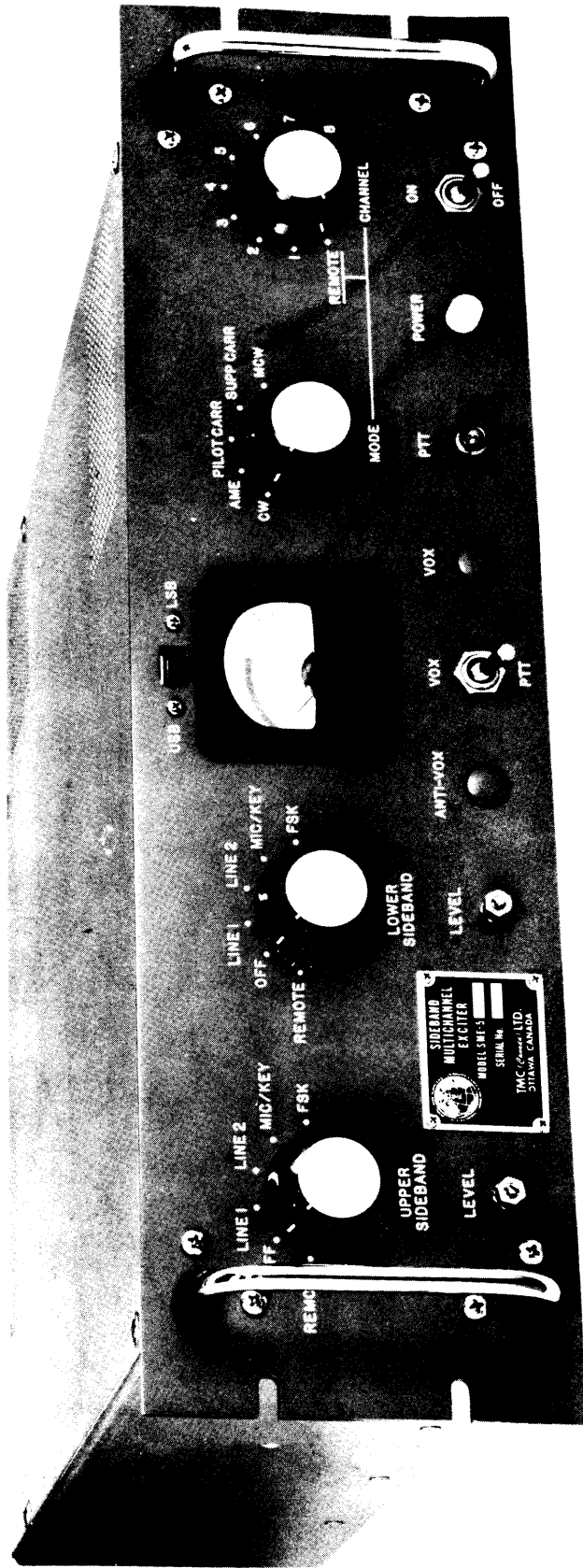

Figure 1-1, SME-5 MULTI-MODE EXCITER

SECTION 1

GENERAL INFORMATION

1.1 FUNCTIONAL DESCRIPTION

The sideband multi-channel Exciter Model SME-5, (figure 1-1) is a fully solid-state, eight channel ISB Exciter with a frequency range of 2 to 30 MHz. It delivers up to 100 milliwatts PEP output power in the following modes:-

TYPE OF TRANSMISSION	CODE	REMARKS
Amplitude modulation equivalent (AME)	A3H	
Continuous wave (CW)	A1	
Modulated continuous wave (MCW)	A2H	
Single sideband either upper and/or lower sideband	(USB and/or LSB)	A3J
Pilot carrier		A3A
Independent sideband (ISB)		A3B
Frequency Shift Keying (FSK)	F4	Optional

The SME-5 is designed to accept audio inputs from two(2) 600 ohm lines, a carbon microphone, a dynamic microphone (low Z and high Z) and a CW key. Two independent audio inputs may be provided for simultaneous transmission. These may be either two line inputs, or one line input and one microphone or CW key input. Provision is made for connection of an external modulated 1.75 MHz IF signal in place of the audio inputs. FAX operation can be provided using an external frequency shift generator. The SME-5 is capable of operating on any one of eight preset channels within its frequency range. Operating frequencies are determined by tuned RF assemblies and oven-stabilized, crystal-controlled HF oscillators. The thirteen available RF boards and their frequency ranges are listed in Table 1-1.

RF BOARD	FREQUENCY RANGE IN MHz
A10795-6	2 to 2.5
A10795-7	2.5 to 3
A10795-8	3 to 4
A10795-9	4 to 5
A10795-10	5 to 6
A10795-11	6 to 8
A10795-12	8 to 10
A10795-13	10 to 12
A10795-14	12 to 15
A10795-15	15 to 18
A10795-16	18 to 21
A10795-17	21 to 26
A10795-18	26 to 30

Table 1-1

RF Board Frequency Ranges

Optional Facilities can be provided for:-

1. FSK - by insertion of a printed circuit assembly. FSK inputs of 20/60 ma polar or neutral, dry contact, 50 or 100 volts positive, or $\pm 6v$ (E1A-232C), can be used up to a maximum of 200 bauds.
2. VOX/ANTI-VOX - by addition of the optional PC assembly and front panel controls, this facility is available for use on the selected sideband.
3. EXTENDED LINE SELECT - By addition of a PC board for each sideband the functions of the LOWER SIDEBAND switch S1 and/or the UPPER SIDEBAND switch S2 can be extended for remote control.
4. EXTENDED MODE & CHANNEL SELECT - By addition of a PC board the functions of MODE switch S3 and the CHANNEL switch S4 can be

extended for remote control. Since this option requires additional wirings, this should be factory installed.

The components supplied as loose items with the SME-5 are listed in Table 1-2.

NAME	DESIGNATION	FUNCTION	QTY.
Service Extension Board Assembly	A10869	Aid in maintenance procedures for the RF Boards.	1
Terminal Strip	TM105-9-AR	Connection strip for TB1 thru TB3.	3
Connector	MS3106A-16S-5S	Mating connector for J14	1
Connector	UG88	Mating connectors, J126 (EXT IF), J127 (ALDC), and J128 (RF OUT)	3
Clamp	MS3057-8	Strain relief for the power cable	1
Connector (provided when option fitted)	MS3102-28-11P	Mating connector for J119 (remote control)	1
Connector	MS3102-20-27P	Mating connector for J120	1

Table 1-2 Loose Items Supplied with the SME-5

1.2 PHYSICAL DESCRIPTION

The SME-5 is designed for track-slide mounting in a standard nineteen-inch rack. All the operator's controls are mounted on the front panel of the unit. The remaining controls and all connectors and terminal strips are located on the rear panel.

The majority of the electronic components are mounted on printed circuit boards that plug into connectors on the main chassis. The remainder are chassis mounted.

1.3 TECHNICAL SPECIFICATIONS

Frequency Information

Range: 2.0 to 30 MHz

Presentation: Channel selector switch 1-8

Stability: Temperature controlled crystal oscillators for Max Deviations of ± 10 Hz from 0°C to 50°C

Power Distortion & Noise

Power Output: 0 to 100 mw PEP

Output Impedance: 50 ohms nominal unbalanced

Intermodulation Distortion: At least 40 db below either tone of a two tone test at 100 mw PEP output.

Spurious Signal: Better than 50 db down at full PEP output.

Harmonic suppression: 2nd order at least 45 db below full PEP

Hum & Noise: Better than 50 db down at full PEP

Operational

Modes: AME, CW, MCW, ISB, LSB, USB, FSK (option), FAX (with external F.S. Generator) (option)

Tuning: 8 preset crystal controlled channels, covering any frequency in the range 2.0 to 30 MHz.

Metering: Built-in meter permits monitoring of USB and LSB audio input levels.

ALDC: Automatic Load & Drive Control accepts 0 to -11 volts d.c. from ALDC circuit of associated linear to deliver a relatively constant RF output level during high modulation peaks.

Carrier Insertion: Level of carrier is continuously variable from 0 to -50 db, on AME and pilot carrier.

Audio

Response, sideband filters Standard 300-3000 Hz ± 1.5 db
Other bandwidths can be supplied as a customer option.

Input Line: Dual inputs - 20 to 10 dbm at 600 ohms balanced or unbalanced.

Microphone Input Control: Microphone selection via USB or LSB switch control, for high and low impedance dynamic microphones or carbon microphone.

Voice Operated Relay (VOX) Voice controlled switch with adjustable threshold (optional).

Keying Information

CW Rear panel dry contact (up to 200 bauds)

FSK (1) 20/60 ma polar or neutral
(2) Dry contact
(3) 50 or 100 volts positive
(4) $\pm 6V$ (EIA-232C)

FSK Shift Any shift up to 2700 Hz with plug-in crystals for Mark and Space tone frequencies.

FSK Keying Speed 200 Bauds.

Installation & Environmental Data

Environmental: 0°C to 50°C up to 90% humidity

Storage: -40°C to 85°C, 95% humidity

Size: 5- $\frac{1}{2}$ inches (13.3 cm) high x 19 inches (48.25 cm) wide x 18 inches (45.57 cm) deep.

Weight: 30 lbs. (14 kg.)

Primary Power:

115/230 volts, 50/60 Hz

Component & Construction:

All equipment manufactured in accordance with JAN/MIL specifications, wherever practicable.

SECTION 2 INSTALLATION

2.1 UNPACKING AND HANDLING

The SME-5 is tested at the factory prior to shipment. When the SME-5 is received at the operating site, inspect container and contents for possible damage in transit. The equipment supplied with the SME-5 (Table 1-2) is packed in the box as loose items.

With respect to damage to the equipment for which the carrier is liable, TMC (Canada) Limited will assist in describing methods of repair and furnishing of replacement parts.

2.2 POWER REQUIREMENTS

The SME-5 is designed for 115/230 vac, 50/60 Hz single phase power operation. Unless specifically ordered, the unit is wired for 115 vac operation. To change to 230 vac operation, remove straps 1-3 and 2-4 on the power transformer, strap terminals 2-3, and connect AC wiring to terminals 1 and 4 (see figure 7-1).

2.3 MECHANICAL INSTALLATION

The SME-5 should be mounted in a location that will allow sufficient clearance for making connections to the rear panel and provide access to the operating controls on the front panel.

2.4 ELECTRICAL INSTALLATION

All electrical connections between the exciter and associated equipment are made at the rear of the unit (figure 2-1). Table 2-1 lists the function of each input connection. Connector J119 is provided for connection of remote control options (see figure 7-1 for connections).

Panel Designation	Function
J14 (Power)	Power input for 115 vac or 230 vac line power.
J119	Optional input connector for remote control operation.
J120	Band Select outputs.

Table 2-1 Rear Panel Connections

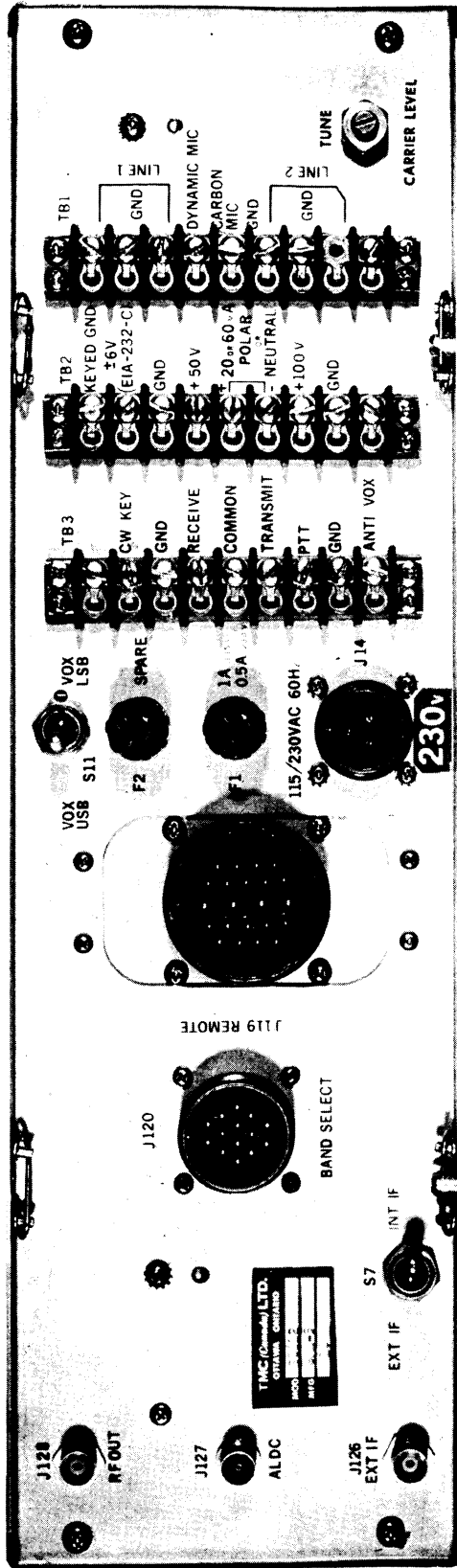

Figure 2-1, SME-5 REAR PANEL

Panel Designation	Function
J126	External IF input Jack
J127	ALDC input from an associated linear amplifier to deliver a relatively constant RF output level during high modulation peaks.
J128	RF output connector
<u>TB1</u> Audio Inputs	
1, 2 -3	600 ohm balanced input line 1
4	Dynamic Mike input
5	Carbon Mike input
6	GND
7-9	600 ohm balanced input Line 2
<u>TB2</u>	
-1	Keyed ground connection
-2	+6V (EIA-232-C)input
-3	GND
-4	+50V
-5, -6	20 or 60 mA Polar or Neutral
-7	+100V
-8	GND
-9	Auto Tune
<u>TB3</u>	
-2	CW Key
-3	GND
-4, -5, -6	External control from PTT relay

Table 2-1 Rear Panel Connections (cont'd)

Panel Designation	Function
-8	GND
-7	PTT
-9	ANTI-VOX

Table 2-1 Rear Panel Connections (cont'd)

2.5 PERFORMANCE CHECK

After the SME-5 has been installed and all electrical connections have been made, it should be checked for proper operation. It is recommended that the operator should read Section 3 before proceeding with this check. For front panel controls refer to figure 2-2.

- (a) With power switch S10 to its off position disconnect the RF output cable from J128 and connect a dummy load (47 ohm, $\frac{1}{2}$ watt resistor) to it. Connect an oscilloscope across the dummy load. Switch on the primary power and carry out following for each channel:-
- (b) Turn the LOWER SIDEBAND switch to OFF.
- (c) Select the SUPP CARR mode.
- (d) Using the UPPER SIDEBAND switch, select LINE 1. With a line 1 audio input of -20dbm and the push-to-talk switch closed (or terminal 7 on TB3 grounded), check for the presence of an output signal on the oscilloscope. Repeat for all microphone and line inputs, setting the UPPER SIDEBAND switch to the appropriate position.
- (e) Select in turn PILOT CARR mode and AME mode. Repeat step (d).
- (f) Turn the UPPER SIDEBAND switch to OFF.
- (g) Repeat steps (C) to (E) using the LOWER SIDEBAND switch to select the audio input.
- (h) Turn the LOWER SIDEBAND switch to OFF.
- (i) Select the CW mode.

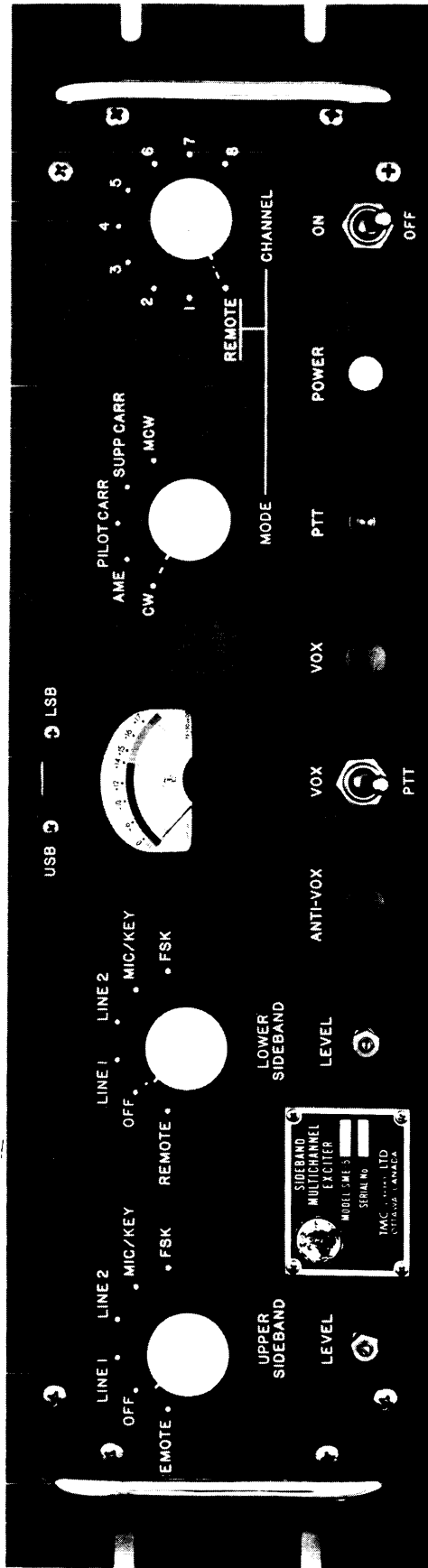

Figure 2-2, SME-5 Front Panel

- (j) Set the UPPER SIDEBAND switch to MIC/Key using an external key to provide the input signal (TB3 terminal 2), check for the presence of an output signal on the oscilloscope.
- (k) Turn the UPPER SIDEBAND switch to OFF.
- (l) Repeat steps (J) and (K) using the LOWER SIDEBAND switch to select the key input.
- (m) Select the MCW mode and repeat steps (J) to (L).
- (n) Switch off the primary power, disconnect the dummy load and oscilloscope and reconnect the RF output cable to J128.

SECTION 3

OPERATOR'S SECTION

3-1 CONTROLS AND INDICATORS

Before attempting to operate the SME-5, the operator should become familiar with the controls and indicators of the unit. Table 3-1 gives the designation and a brief description of the function of each control and indicator.

DESIGNATION	FUNCTION
LOWER SIDEBAND switch (S1)	Selects the audio input for LSB operation; REMOTE, OFF, LINE 1, LINE 2, MIC/KEY, FSK.
UPPER SIDEBAND switch (S2)	As above for USB audio input.
MODE switch (S3)	Selects the mode of operation: CW, SUPP CARR, PILOT CARR, AME, MCW.
CHANNEL SELECT switch (S4)	Selects one of the available operating frequencies (up to 8 channels), or REMOTE control of both channel and mode selection when this option is provided.
EXT/INT IF switch (S7) (Rear panel)	Permits operation by an external IF signal.
USB/LSB switch (S9)	Connects audio metering circuit to USB or LSB.
ON/OFF switch (S10)	Primary power switch.
VOX USB/LSB switch (S11) (Rear panel)	Selects sideband for VOX control, this switch is only functional when VOX option is fitted.
LSB LEVEL control (R3)	Adjusts audio level to line amplifier.
USB LEVEL control (R4)	Adjusts audio level to line amplifier.
PTT Lamp (DS1)	Lights when PTT relay is operative.

Table 3-1 SME-5 Controls and Indicators

DESIGNATION	FUNCTION
POWER Lamp (DS2)	Lights when primary power is present and S10 is ON.
The following controls are provided on the front panel when the VOX option is installed:	
VOX/PTT (S8)	Selects operation by PTT or VOX.
VOX level control (R12)	VOX gain control.
ANTI-VOX level control (R13)	ANTI-VOX gain control.

Table 3-1 SME-5 Controls and Indicators (cont'd)

3.2 OPERATING PROCEDURES

This general operating procedure is given to aid the operator in the correct use of the controls.

- (a) Turn on the primary power (S10).
- (b) Select the desired operating frequency by setting the CHANNEL SELECT switch to one of channels 1 to 8.
- (c) Select the desired mode of operation by setting the MODE switch to CW, SUPP CARR (suppressed carrier), PILOT CARR, AME (AM equivalent) or MCW.
- (d) For USB (upper sideband) operation, set the UPPER SIDEBAND switch for the desired audio input: LINE 1, LINE 2 or MIC/CW (or FSK if provided).
- (e) For LSB (lower sideband) operation, set the LOWER SIDEBAND switch for the desired audio input.

NOTE

Independent LSB and USB inputs may be selected simultaneously.

- (f) To activate the SME-5 on PTT (push-to-talk): press the PTT switch on the microphone or ensure that terminal 7 on

TB-3 is grounded. For VOX operation, adjust VOX GAIN control while speaking into mike until DS1 (PTT indicator) lights.

NOTE

The PTT relay must be released when changing channels.

- (g) If it is desired to use an IF input from an external source, rather than audio inputs, set switch S7 on the rear panel to the EXT IF position.

SECTION 4

PRINCIPLES OF OPERATION

4.1 GENERAL

A simplified functional block description of SME-5 is given in para 4.2, followed by circuit description of individual module as detailed below. The schematic diagrams of each section are given in Section 7.

Para 4.3 Power supply section

4.4 Audio inputs and circuits

4.5 IF circuits

4.6 Mixer/Doubler

4.7 HF Oscillator

4.8 RF Amplifier

4.9 Wideband Amplifier

4.10 FSK inputs and circuits

4.11 Extended line select

4.12 Extended mode and channel select

4.2 FUNCTIONAL BLOCK DESCRIPTION OF SME-5 (Figure 4-1)

The principles of operation of both LSB and USB are identical. For ease of explanation only LSB operation is described. When following the USB operation, LSB switch S1 is replaced by USB switch S2. Audio input from an external source is fed through input filter A17 to the primary of transformer A20T1. The output is taken at the potentiometer A20R6 and fed to the LSB input selector switch S1. S1 routes the selected input through LSB LEVEL adjust potentiometer R3 to the transformer A20T2. The output of the transformer A20T2 is fed to the IF board A9. This output is also fed to a metering circuit A7, through meter switch S9. The meter M1 is mounted on the front panel and enables the operator to set the correct audio level. The IF board is a modulator-oscillator. It combines the audio signal with the local oscillator frequency of 1750 KHz. The modulated output of the IF board is fed to the mixer doubler A13. The mixer-doubler is controlled by channel switch S4. It doubles, under certain conditions, the input signal from the HF oscillator A12 and mixes it with the intermediate frequency supplied by the IF board A9. The HF oscillator is also controlled by channel switch S4. The output of the mixer-doubler A13 can be any one of the 8 channel frequencies selected by channel switch S4. The selected output of A13 is fed to the appropriate section of RF amplifier A14. The RF amplifier consists of eight boards, only one of which is operative at a time as determined by the

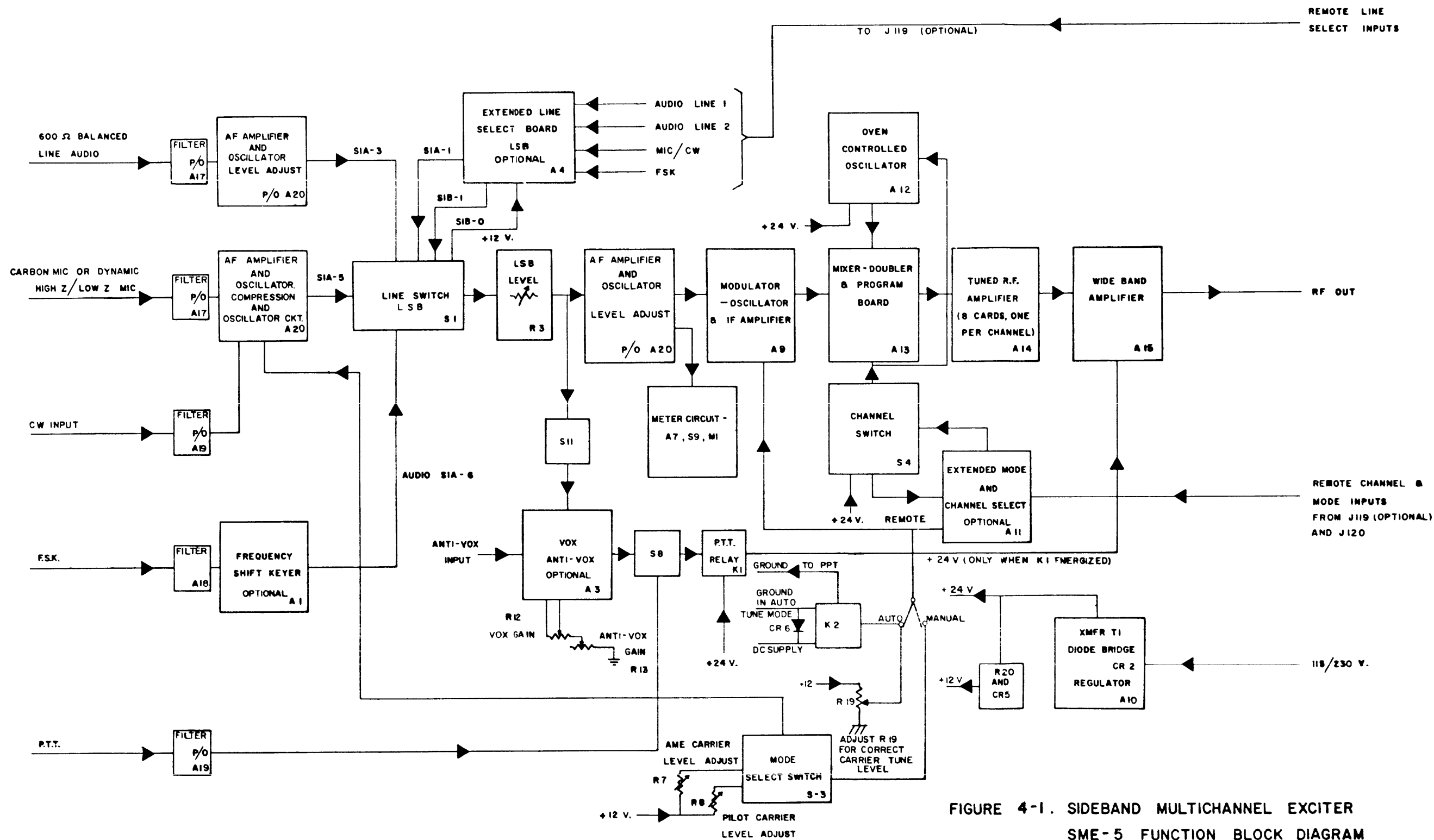

FIGURE 4-1. SIDEBAND MULTICHANNEL EXCITER SME-5 FUNCTION BLOCK DIAGRAM (LSB OPERATION ONLY)

channel switch. The output of the RF amplifier is fed to the wideband amplifier A15, which delivers the maximum RF output of 100 mw PEP into a 50 ohm load.

The carbon microphone, the dynamic microphone input or the CW input, when selected are fed through an AF amplifier and oscillator board A20. The output of A20, a 1000 Hz or compressed AF signal at a level of -20 dbm to +10 dbm is coupled to A9 as an audio input.

FSK inputs (optional) are first fed through input filter A18 to FSK board A1. The FSK inputs being in the form of teletype information is converted into an audio input in the board A1 and fed to the S1A-6 for onward transmission in the same manner as line audio input.

VOX/ANTI VOX (optional) is operated by switching VOX USB/LSB switch on the rear panel to any position. A portion of audio is fed to VOX/ANTI-VOX board A3, where the predetermined level of audio operates relay K1 (S8 in VOX position). When energized, K1 applies +24 volts to wideband amplifier A15.

Extended line select boards A4 (LSB) and/or A5 (USB) (both optional) are provided for remote control of the unit. When S1/S2 is in REMOTE position, +12 volts is supplied to the relay in A4 (A5) which in turn routes the selected input for transmitting in the usual manner.

Extended mode and channel select A11 (optional) is provided for selection of channel and/or mode from remote location. This board operates when S4 is in REMOTE position.

The unit can be operated from 115/230 volts ac. The power supply section consists of a transformer, a rectifier, and a regulator. The regulated supplies required for operation of SME-5 are +24 vdc and +12 vdc.

4.3 POWER SUPPLY SECTION (Figure 7-1 and Figure 7-2)

SME-5 can operate from 115/230 vac power source. Changeover from 115 vac or vice versa can be made by simple modification of the input power transformer wiring and changing of the fuse value. The rating of the fuse required for 230 vac operation is half of that required for 115 vac operation. AC power source is coupled to power connector J14. AC power supply from J14 is applied to the primary of transformer T1 through fuse F1 and switch S10. The output at the secondary of T1 is rectified by bridge rectifier CR2 and then smoothed by electrolytic capacitors C2, C3 and C4. This unregulated dc supply is applied to the regulator board A10. Transistor Q1 and transistor A10Q1 form a darlington pair and provide the voltage and current regulation. Transistor A10Q2 and Zener diode A10CR1 form a voltage reference circuit sensitive to load changes. Resistor A10R4 sets the voltage level. The output at the emitter of Q1, a +24 volts regulated dc supply is applied to the various SME-5 circuits. +12 volts regulated supply is obtained from the 24 volts regulated supply through a dropping resistor R20 and regulating Zener diode CR5.

4.4 AUDIO INPUTS AND CIRCUITS

Audio inputs and circuits are explained in the following subparagraphs. FSK board which is an optional item and other remote control options are explained separately in their respective paragraphs.

4.4.1 AF AMPLIFIER AND OSCILLATOR A20 (figure 7-1 and figure 7-3)

AF amplifier and oscillator A20 produces a 1000 Hz or compressed AF signal at a level of -20 to +10 dbm from a CW key input, a carbon microphone input or a dynamic microphone low Z or high Z input. In addition to the amplifier and oscillator circuits, it also contains level adjust potentiometers and line transformers.

When a carbon microphone is used, the signal is coupled through the input filter A17 to pin 2 of A20. Link 1 must be strapped on the printed circuit board, and link 2 must be open. The signal is then coupled to the gate of preamplifier A20Q2 through coupling capacitor A20C9, isolating resistor A20R11 and input level adjust potentiometer A20R14. The amplified signal is coupled through A20C12 to the input of gain controlled amplifier A20A2. The amplified signal at pin 5 of A20A2 is coupled through A20C14 to the input of source follower A20Q3. A portion of audio output at pin 2 of A20Q3 is fed through the agc level control potentiometer A20R19 to the input of agc generator A20A3. A20A3 is an agc generator which generates a suitable agc voltage directly from the audio signal. In addition it provides a 'hold' period to maintain the agc level during pauses in speech, and is immune to noise interference. The agc voltage produced in A20A3 controls the gain of amplifier A20A2. The output of source follower A20Q3 is also coupled through A20C20 to amplifier A20A4. A20R33 is a feedback potentiometer and sets the gain of A20A4. The amplified signal is coupled through A20C26 to pin 5 as compressed audio output at a level of -20 to +10 dbm. A20CR4, A20CR5 and associated components form a clipping circuit to prevent the accidental overloading of the transmitter. Clipping level is set by clipping level adjust potentiometer A20R37. The output signal at pin 5 of A20 is fed to the AF board A9 as audio input through front panel LSB/USB switch S1/S2.

When dynamic microphone low Z or high Z input is used, signal is coupled through the input filter A17 to pin A of A20. Link 1 for carbon microphone input is removed from its terminals and link 2 is connected to Low Z microphone input terminals. For a high Z input neither of the two links are connected. The signal is then transmitted to the output pin 5 of A20 in the same manner as carbon microphone input.

In the CW mode of operation, CW key input is coupled to pin 4 of A20 through input filter A18. CW keying input is connected to the oscillator A20A1. A20C5 and A20L1 form a 1 KHz parallel resonant circuit for A20A1. The output of the oscillator is fed to the input of the emitter follower A20Q1. The output of A20Q1, a 1 KHz signal interrupted by the keyer input, is fed to amplifier A20A4 for amplification and transmission in the same manner as a microphone input. The compression amplifier circuit is disconnected during CW mode by a positive supply to the source of A20Q3 through diode A20CR2.

A20T1 through A20T4 are audio transformers, two for LSB operation and two for USB operation. Line audio is connected through input filter A17 to the primary of A20T1 (A20T3). The output at the secondary of A20T1 (A20T3) through level adjust potentiometer A20R6 (A20R7) is fed to the LINE 1 (LINE 2) position on LSB (USB) switch S1 (S2). The selected output of S1 (S2) is fed via LSB (USB) level potentiometer R3 (R4) and A20T2 (A20T4) to the input of IF assembly A9, as audio input.

4.4.2. METERING CIRCUIT A7 (figure 7-4)

Meter switch S9 connects either LSB or USB to the metering circuit A7. A7 is an amplifier detector. The signal is coupled to the base of A7Q1. The amplified output at the collector of A7Q1 is detected by diodes A7CR1 and A7CR2. The detected output a relative amplitude of the LSB or USB signal is monitored on the front panel meter M1. The potentiometer A7R5 provides the means of calibrating the meter M1.

4.4.3 VOX/ANTI-VOX OPERATION (figure 7-1 and figure 7-5)

VOX/ANTI-VOX operation can be fitted as an option. A printed circuit board A3 is fitted and the required front panel controls are added. The line audio is connected through switch S11 to pin M of J4. The audio is fed to integrated circuit A3A1 where it is amplified and then fed to the detecting circuit consisting of A3CR1 and A3CR2. The positive detected output is developed across front panel VOX GAIN control R12. Similarly ANTI-VOX input is coupled through TB-3 pin 9 and pin N of J4 to integrated circuit A3A2 and then to the detector A3CR3 and A3CR4. The negative detected output is developed across front panel ANTI-VOX GAIN control R13. Both detected outputs are added algebraically and then amplified in three stage amplifier A3Q1, A3Q2 and A3Q3. The output at the collector A3Q3 is used to operate the PTT relay K1, when VOX/PTT switch S8 is in the VOX position. A time delay circuit A3R8 and A3C12 is used to prevent release of the PTT relay during normal gaps in conversation and may be adjusted by R8.

4.5 IF BOARD - A9 (Figure 7-6)

NOTE

All 1800 series components are mounted on IF board A9.

Two balanced modulators, CR1801 - CR1804 and CR1805 - CR1808, combine the USB and LSB signals with the 1750 KHz signal from oscillator Z1801. RF switches Q1805 and Q1806 control the insertion of the oscillator signal. When the UPPER SIDEBAND switch S2 is in the OFF position, +12 volts is connected through wafer B of S2 to the IF board pin 5 to bias Q1805 off so that 1750 KHz is not inserted across modulator CR1805-CR1808, and the modulator output will not pass USB filter FL1802. For any but the OFF position of S2, the +12 volt supply is disconnected from Q1805. As a result, Q1805 conducts, inserting the 1750 KHz signal, and the frequency of the output from the modulator is then within the bandpass of FL1802 (1747.0 to 1749.7 KHz). Similarly, when the LOWER SIDEBAND switch S1 is in the OFF position, +12 volts is connected through wafer B of S1 to bias off Q1806, the 1750 KHz is not inserted across modulator CR1801-CR1804, and the output from the modulator does not pass LSB filter FL1801. For other positions of S1, +12 volts is not applied to Q1806, it conducts, 1750 KHz is inserted across the modulator, and the output is within the bandpass of FL1801 (1750.3 to 1753.0 KHz). The audio modulated IF signals are amplified by 1st and 2nd IF amplifiers Q1801 and Q1802.

For operation in pilot carrier, AME or MCW mode, it is necessary to insert carrier from oscillator Z1801 at 2nd IF amplifier Q1802. The amount of carrier inserted is controlled by carrier switch Q1807 and variable resistors R7 and R8. When the PILOT CARR mode is selected by mode switch S3, the voltage set by R8 is applied through wafer A of S3 and diode CR3 to terminal 7 on the IF board to bias Q1807 on and determine the amount of carrier inserted. In AME or MCW mode, the voltage set by R7 is similarly provided through S3 and CR3 to bias Q1807 on and determine carrier. In suppressed carrier and CW modes, Q1807 is biased off by +12 volts supplied through S3 and CR3.

Crystal Y1801 and capacitor C1813 form a notch which removes any undesirable carrier from the output of 2nd IF amplifier Q1802 during CW and suppressed carrier operations. Notch switch Q1808 disables Y1801 in the pilot carrier, AME and MCW modes. When the carrier control input on terminal 7 is +12 volts, notch switch Q1808 is biased off, and the operation of Y1801 is not affected. An ALDC signal at terminal 9 on the IF board is connected to 2nd IF amplifier Q1802 through buffer Q1804 and ALDC amplifier Q1803. This signal reduces the IF output resulting from high level audio inputs, to prevent overloading the RF stages. It is a delayed signal derived from a portion of the RF output of a linear amplifier.

4.6 MIXER DOUBLER A13 (Figure 7-7)

The mixer doubler assembly A13 may be divided into three sections for explanation:

4.6.1 Programmer

4.6.2 Frequency doubler

4.6.3 Mixer

- 4.6.1 The programmer section controls power switching to the RF amplifiers, the HF oscillators, and the frequency doubler, depending on the channel selected and the programme strapping on this board. The CHANNEL switch S4 extends +24 volts to the appropriate terminal on the mixer doubler board for each channel selected. Using Channel 1 as an example, +24 volts is fed via RF filter A13L1/A13C1 and terminal 25 to the Channel 1 RF amplifier; via A13R1 and terminal 2 to the Channel 1 HF oscillator; and via A13CR1 and terminal 17 to terminal 33, 36 or 37 via the programme straps. Below 20 MHz the frequency doubler is not required and the terminals 17 and 33 are strapped. Between 20 MHz and 26.75 MHz, the frequency doubler is required. A13R13 is preset to provide a control voltage to A13CR14 for an output of frequency in the range of 20 - 26.75 MHz. To provide supply voltage to this circuit terminals 17 and terminals 36 are strapped. Between 26.75 and 30 MHz terminals 17 and 37 are strapped to include A13R17 to provide the required preset voltage to A13CR14. Similarly strapping is made for each of the eight channels depending on frequency (Ref Simplified Block Schematic fig. 4-2).
- 4.6.2 The frequency doubler consists of transistor A13Q1 and its bias circuitry. Inductor A13L10 and vari-cap A13CR14 form the high Q resonant collector load which is tuned to the required frequency band 20 - 26.75 MHz or 26.75 - 30 MHz by the pre-set potentiometers A13R13 and A13R17 respectively. A13Q3 is a buffer stage for the frequency doubler and A13Q2 is a buffer for signals not routed through the doubler path.
- 4.6.3 The gate of mixer A13Q4 receives the signal from either A13Q2 or A13Q3. The mixer load is transformer A13T1. The IF frequency is injected into the centre-top of the secondary of A13T1 switched by diodes A13CR16 and A13CR17. Potentiometer A13R29 and pre-set capacitor A13C27 are adjusted to balance out the HF carrier frequency. The RF output is routed to RF amplifiers via pin 41.

4.7 H.F. OVEN OSCILLATOR A12 (Figure 7-8)

The HF oven oscillator consists of eight separate oscillator circuits with common buffer stages, all housed in a temperature controlled oven. The oven control circuit A12A1 (figure 7-9) consists of thermistor A12A1RVT101 drivers A12A1Q101 and A12A1Q102 and heater transistor A12A1Q103.

Only one oscillator circuit is switched on, controlled via the programmer section of the Mixer/Doubler assembly A13 by CHANNEL switch S4.

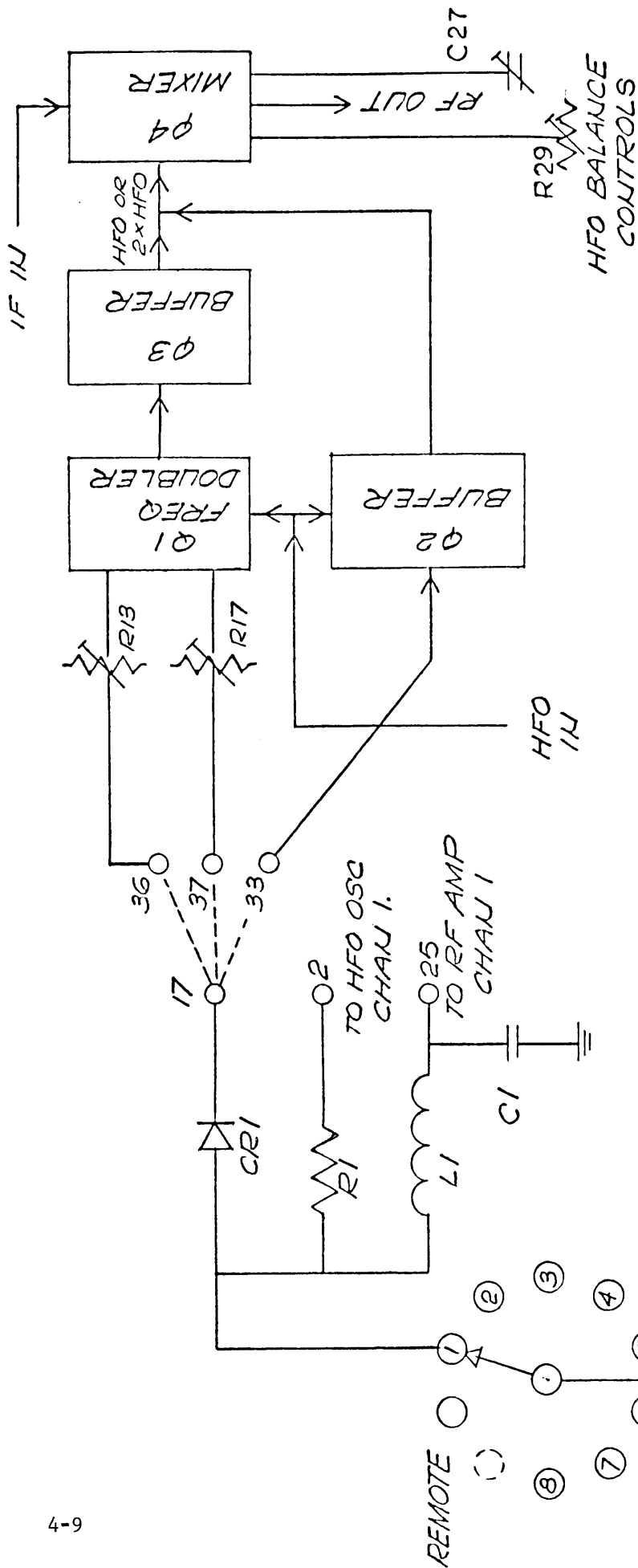

FREQ RANGE MHz	STRAP	TUNING
2-20	17-33	—
20-26.75	17-36	R13
26.75-30	17-37	R17

MIXER/DOUBLER, A13
SIMPLIFIED SCHEMATIC
(CHANNEL 1 SHOWN AS TYPICAL)

FIG. 4-2

Crystal frequencies are determined as follows:-

$$2 - 20 \text{ MHz} \quad f_x = f_R + f_I$$

$$20-30 \text{ MHz} \quad f_x = \frac{f_R + f_I}{2}$$

Where f_x = crystal frequency

f_R = Desired Receive Signal (Carrier Frequency)

f_I = 1750 kHz (the IF frequency)

4.8 RF AMPLIFIERS A14 (Figure 7-10)

The RF signal from the Mixer/Doubler is paralleled to the inputs of up to eight RF amplifier assemblies. Only one RF amplifier is energized with +24 volts as determined by the position of Channel Switch S4 via the programme section of the Mixer/Doubler. The RF signal is amplified by stages A14Q1, 2 and 3. The basic RF amplifier assemblies are common, the operating frequency band is determined by components A14C2, 4, 9, 15 and A14T1, 2, 3, 4. Frequency bands are detailed in Table 1-1, page 1-3.

4.9 WIDEBAND AMPLIFIER A15 (Figure 7-11)

The output of the RF amplifier is amplified in a wideband amplifier A15. A15 is a class "A" two stage amplifier with an input and output impedance of 50 ohms. A15T1 and A15T2 are wideband transformers. A15R4 adjusts the base current of the second stage A15Q2 to obtain the maximum linear response. The wideband amplifier delivers a maximum RF output of 100 mw PEP in 50 ohms load.

4.10 FREQUENCY SHIFT KEYER (FSK) A1 (Figure 7-12)

This board is supplied as optional item. Frequency shift keying (FSK) is the transmission of teletype information. The teletype machine has two output states, MARK or SPACE. These outputs must be converted to two corresponding audio tones in the range of 300-3000 Hz. The adaptor must also work from several keying standards. The FSK circuit consists of: (see Fig. 4-3 block diagram)

4.10.1 Keying circuits

4.10.2 Two HF Oscillators

4.10.3 Electronic gate

4.10.4 Frequency Divider

4.10.5 Bandpass amplifier

4-10

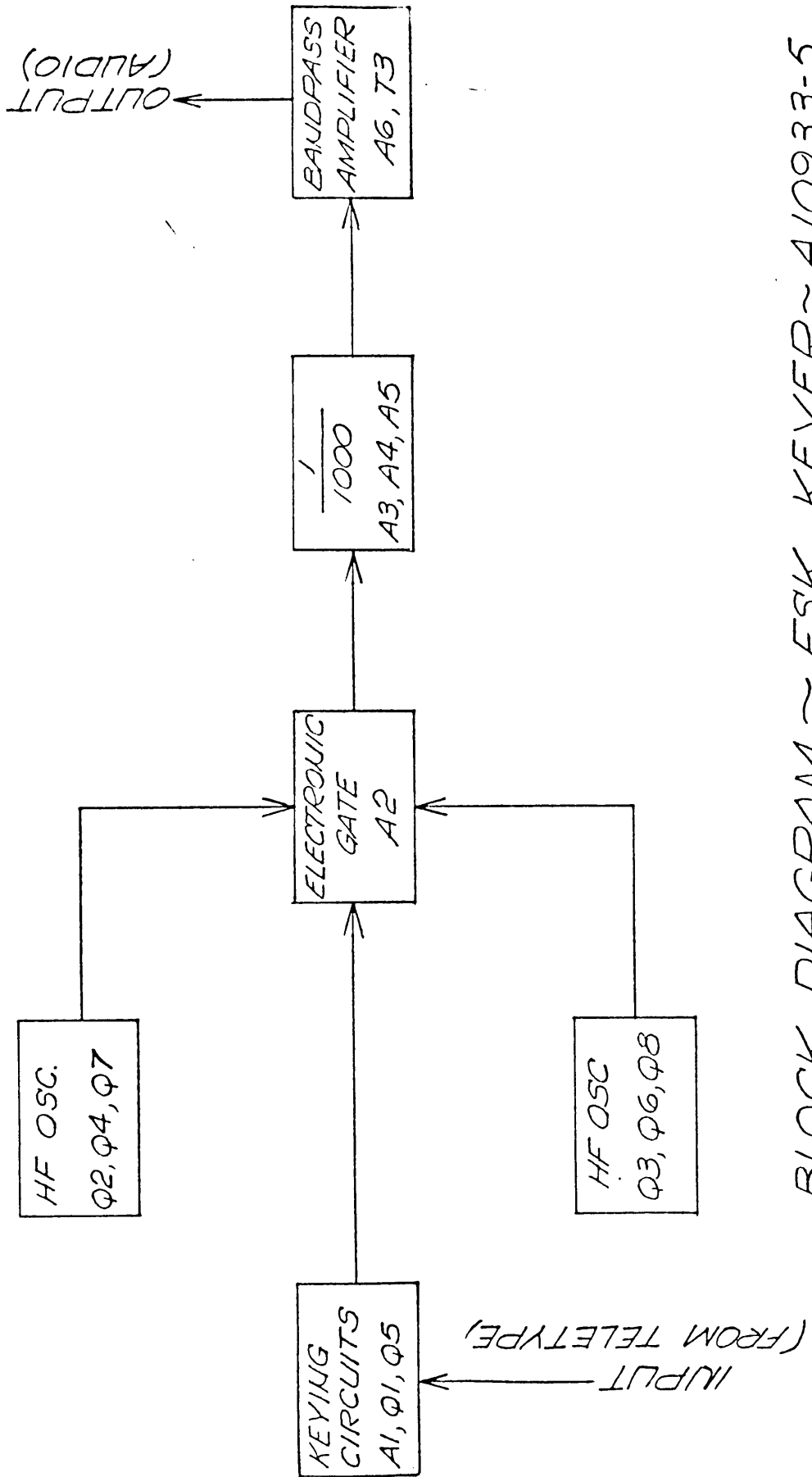

BLOCK DIAGRAM ~ FSK KEYER ~ A109333-5

Fig 4-3

4.10.1 KEYING CIRCUITS. The input to the keying circuits may be either voltage Keying (+50 V or +100 V), keyed ground, loop keying (20 mA or 60 mA, polar or neutral) or EIA keying (+6V to +25V). For voltage, loop or ground keying a jumper should be added between pins C and 19 of J3 and for EIA type keying a jumper should be added between pins C and R of J3.

- (a) Voltage Keying: The +100 volts or +50 volts is brought in at pins 17 or 18 of J3 respectively. The resistive divider A1R3, A1R7 or A1R2, A1R7 output is approximately 10 volts in either case. This voltage makes A1Q5 conduct, consequently the +5 volts is dropped across A1R15 and the collector of A1Q5 is now at 0 volts. This change is applied to pins 1 and 2 of electronic gate A1A2a. Thus, for a MARK input, (+100 V or +50 V) the input to the electronic gate is at 0 volts, for a SPACE input (0V) the gate input is at +5 volts.
- (b) Keyed ground: When a ground is provided at pin 20 of J3 current will flow through A1R15 and A1CR1. The 5 volts is dropped across A1R15 and the input to the gate is at 0. Without a ground at pin 20 the input to the gate is at +5V.
- (c) Loop Keying: The loop inputs are connected to pins 7 and 9 of A1. A1Q1 and its associated circuitry form a 10 KHz Hartley oscillator. The signal is coupled through two transformers A1T1 and A1T2 to rectifier bridge A1CR6 - A1CR9. The rectified output is coupled to the transistor switch A1Q5 which keys the gates A1A2a and A1A2c.

When the polarity of the input is such that the centre tap of A1T2 primary is positive with respect to the centre tap of A1T1 secondary, A1CR4 and A1CR5 are reverse biased and no signal is fed to the base of A1Q5. A1Q5 is turned off. +5V is fed to the input of gates A1A2a and A1A2c. When the polarity of the input signal is reversed A1CR4 and A1CR5 are forward biased. Consequently the rectified signal at the base of Q5 turns it on thereby providing the ground to the inputs of the gates.

- (d) EIA type keying: A1A1 converts the varying EIA input on pin T of J3 to 0 volts for a MARK condition and +5 volts for a SPACE condition, which is fed via pins R and C of J3 to the input of the electronic gate A1A2.

- 4.10.2. HF OSCILLATORS There are two identical oscillators, one acts as a MARK OSCILLATOR and the other as SPACE OSCILLATOR. The oscillator is made up of a crystal A1Y1 (A1Y2) oscillator A1Q2 (A1Q3), a buffer A1Q4 (A1Q5) and a switch A1Q7 (A1Q8). The output of the oscillator and the buffer is basically a sine wave. The transistor switch A1Q7 (A1Q8) converts this into a square wave. The oscillator can be either MARK or the SPACE tone generator, depending on the sense required. The crystal frequency is one thousand times the MARK or SPACE frequency.
- 4.10.3 ELECTRONIC GATE The input at pins 1 and 2 of A1A2 are either 0 volts for MARK or +5 Volts for SPACE. A1A2a inverts this signal and applies it to pin 12 of A1A2b. At the same time the input to A1A2a is applied to the input of A1A2c at pin 4. Since the output of the MARK or SPACE HF oscillator is a positive going square wave A1A2b/A1A2d will only pass the pulses of the MARK oscillator when there is a MARK input and A1A2c/A1A2d will only pass the pulses of the SPACE oscillator when there is a SPACE input. These pulses, or square waves, vary at the selected oscillator rate, dependent on whether we have a MARK or a SPACE condition at the input to the keying circuits. This square wave is applied to the divider at pin 1 of A1A3.
- 4.10.4. FREQUENCY DIVIDER Since the final output from the FSK circuit must be an audio tone, the oscillator signal must be divided by 1000. This is accomplished in three divide by ten stages, A1A3, A1A4, and A1A5. The output is a square wave at one thousandth the input frequency. The frequency of the HF crystal oscillator and frequency divider ensures excellent stability of the audio output tone.
- 4.10.5. BANDPASS AMPLIFIER The output of the divider is a square wave at an audio frequency. The frequency being one thousandth of the HF oscillator frequency selected by the MARK or SPACE input to the keyer circuits. This audio square wave is fed via A1R31 and A1C19 to pin 10 of A1A6. The bandpass characteristics of A1A6 are determined by the values of capacitors A1C16, A1C17, A1C18, A1C19 and A1C20. These remove the higher order of harmonics, the cut-off frequency being 3000 Hz. The sinusoidal audio output is fed via A1T3 to pin Y of J3.
- 4.11. EXTENDED LINE SELECT - A4/A5 (Figure 7-13)

The extended line select card is used to control, from a remote location, the incoming audio and FSK inputs to the IF board. Both cards are identical; A4 is used for LSB operation and A5 is used for USB operation. In an exciter wired for independent sideband operation, two of these boards are used. In an exciter not wired for extended line select, both cards are left out. The form A contacts of the relay A4/A5K1 to A4/A5K4 are connected in parallel with the contacts of sideband select switches S1A or S2A. The REMOTE position of the sideband select switches S1 and S2 puts +12 volts on one end of the five reed relays through positions 6 of S1B or S2B. A ground on any one of the four control pins; 5, 7, 9 or 11 of J1 operates the corresponding relay, closing its contacts, which routes the selected audio (Line 1, Line 2, Mic/Key, FSK) to the wiper of S1A or S2A. From there on the operation is as in the local line select mode.

When the sideband select switches are in the OFF position, relay K5 is released on both boards, and the normally closed contacts apply +12 volts to pins 5 and 6 of the IF board A9, switching the ring modulators on this board off. Diodes CR1, CR3, CR5, CR7 and CR9 on A4/A5 are used as transient suppressors. Diodes CR2, CR4, CR6, CR8, CR10, CR11, CR12, and CR13 on A4/A5 are used for isolation purposes.

4.12 EXTENDED MODE & CHANNEL SELECT, A11 (Figure 7-14)

This board consists basically of two sections; channel select and mode select. Remote channel select only or both functions may be operated from a remote location. Input to the unused function is left open. A jumper is connected between position 1 and 2 of S4B for remote channel select with local mode select operation.

When remote operation of both functions is selected, +24V is applied to pin 10 of J5 from pin 1 of CHANNEL switch S4A. This also removes the +24 volts from the channel select inputs for local operation. Position 1 of S4B removes the +12 volts from the carrier level control potentiometers R7 and R8. It also removes +12 volts from the wiper of S3B, which is required to operate the audio oscillator in the CW and MCW modes. These voltages are not supplied by the extended mode and channel select circuit.

A ground on any one of the channel select inputs on pins 3, 4, 5, 6, R, S, T, or U of J5 operates one of the eight reed relays, A11K1 thru A11K8. This supplies +24 volts to one of the eight positions 2-9 on S4A, which in turn supplies power to the appropriate oscillator and RF card through the mixer doubler board, A13. External band select information for the power amplifier is supplied via wafer C of S4, as shown on the main schematic.

Mode selection is achieved by grounding any one of the five pins 8, 9, 12, 13, or 14 of J5. A ground on the CW or SSB input pin 13 or pin 14 of J5 turns transistor A11Q5 on, and applies +12V on the carrier control input pin 7 on the IF board A9. This cuts off the carrier injection transistor A9Q1807. Similarly a ground on the AME, PC, or MCW input pin 9, 12 or 8 turns either A11Q6 or A11Q7 on and supplies +12 volts to pin 7 on the IF board A9. Potentiometers A11R20 and A11R21 are adjusted to give the correct level of carrier suppression. In the CW and the MCW modes, the transistor A11Q9 is also turned on, which supplies power to the AF amplifier and oscillator A2.

In local operation, absence of +24 volts on Pin 10 prevents operation of the Extended Mode and Channel Select card.

4.13 - AUTOMATIC TUNE (OPTIONAL)

When the unit is fitted with auto tune mode, a relay K2, diode CR6 and potentiometer R19 are provided with connection as shown in figure 7-1. In the AME mode it is necessary to insert carrier to the 2nd amplifier Q1802 in IF board A9. The amount of carrier inserted is controlled by Q1807 on A9 and potentiometer R19. Relay K2 applies a constant PTT condition to the linear amplifier for tuning purposes.

SECTION 5

MAINTENANCE

5.1 PREVENTIVE MAINTENANCE

Preventive maintenance of the SME-5 consists of routine inspection and cleaning. Cleaning is necessary because dust may accumulate on certain components and not only reduce efficiency of the exciter, but also increase component wear. Either a vacuum cleaner or a compressed air hose is the quickest and most effective method of cleaning the unit.

Visually checking the unit when it is opened for cleaning can prevent down-time due to component failure. Often a deteriorating component will look bad before it actually affects the operation of the unit. Some indication of trouble are: discoloured components, leaking transformers and capacitors, dirty or pitted switch and relay contacts, warping printed circuit boards, and damaged wiring. Any components found in this condition should be replaced. In addition, all hardware should be checked for tightness.

5.2 TROUBLESHOOTING (For location of components. See figures 5-1 to 5-12).

(1) POWER SUPPLY SECTION

- (a) When the primary input power is supplied and power ON/OFF switch S10 is switched ON, the POWER lamp (DS2) should come on. If it does not, check fuse F1. If it is intact, check the lamp DS2, transformer T1 and diode bridge CR2.
- (b) Check for +24 volts at the emitter of Q1. If no voltage present, check Q1 and the regulator board A10. If the voltage measured at the emitter of Q1 is different from the required +24 volts, adjust potentiometer R4 on A10 to obtain the required voltage.
- (c) Check for +12 volts at the cathode of CR5. If no voltage present or voltage is not as specified, check zener diode CR5.
- (d) If there is a repeated failure of the fuse F1, check for a short circuit in the +24 volts line.

(2) AUDIO INPUTS AND CIRCUITS

- (a) With the power supply switched OFF, disconnect all external wiring from TB1, 2 and 3.
- (b) Disconnect RF cable from J128. Connect a 47 ohm 1/2W fixed carbon composition resistor across J128.

- (c) Connect a two tone audio generator across terminals 2 and 4 of TB1 and adjust its output for a level of -20 dbm. Adjust R6 potentiometer on A20 for a maximum signal level out on pin S of A20. If there is no measurable audio output on pin S, check transformer T1 and resistor R6 on A20.
- (d) Turn USB switch to OFF and LSB switch to LINE 1. Adjust LSB LEVEL potentiometer for a measurement of approximately -20 dbm audio level at pin 1 and 2 of IF board A9. If there is no audio present, check R3, LSB LEVEL potentiometer and transformer T2 on A20.
- (e) Repeat steps (a) to (d) on the upper side band signal path.

(3) METERING CIRCUIT A7

- (a) Set meter switch S9 to LSB.
- (b) With -20 dbm at pins 1 and 2 of the IF board A9, adjust R5 potentiometer on the meter board A7 for a reading of 0 dbm on the red scale of the front panel meter. If the meter shows no deflection, check the amplifier Q1 and voltage doubling diodes CR1 and CR2 on A7.

(4) IF BOARD A9

- (a) Turn LSB to LINE 1 and USB to OFF.
- (b) With -20 dbm of audio at pins 1 and 2 of the IF board check for a two tone IF signal at pin 8. Adjust R1813, C1806 and C1813 for maximum carrier rejection. Adjust C1812 for maximum output. The carrier rejection should be at least 50 db and the output 500 mv peak to peak. If these conditions are not met, check modulation diodes CR1801-CR1804 and IF amplifiers Q1801 and Q1802.
- (c) Repeat step (b) above for the upper sideband.

(5) HF OVEN A12

- (a) Connect a frequency counter across terminal 34 of mixer doubler board A13.
- (b) Set CHANNEL SELECT switch to Channel 1. Check that the frequency as measured on the counter is same as marked on the crystal Y11. If no output is observed, check oscillator circuit (Q11 and Y11) and buffer amplifiers Q101 and Q102.
- (c) Repeat step (b) above for channel 2 through 8 in turn.

(6) MIXER-DOUBLER BOARD A13

- (a) Connect a two tone balanced audio signal at terminals 1 and 3 of TB1.
- (b) Turn MODE switch to SUPP CARR, LOWER SIDE BAND switch to LINE 1 and UPPER SIDE BAND switch to OFF.
- (c) Connect a ground to terminal 7 of TB2.
- (d) Select a channel whose operating frequency is below 20 MHz. Check for +24 volts on pin 38 and pins 1, 3, 5, 7, 9, 11, 13 or 15 of A13 depending on the channel selected. Check also for approximately +18 volts on pins 2, 4, 6, 8, 10, 12, 14 or 16 depending on the channel selected. If these requirements are not met, check wiring to the board A13.
- (e) Check for correct programme jumpers from pins 17 through pin 24 to pins 33, 36, or 37. (See paragraph 4.6 for details).
- (f) Check for the presence of the HF oven signal at the drain of Q2. If no signal is observed check Q2 and associated buffer components.
- (g) Connect an oscilloscope at terminal 41. If no RF signal is observed, check CR16, CR17 and Q4.
- (h) Select a channel with an operating frequency of between 20 and 26.75 MHz. Check for +24 volts at pin 36. If no voltage is present, check jumper connections (see paragraph 4.6 for details).
- (i) Connect an oscilloscope with X10 probe at the gate of Q4. Check for a signal equivalent to the second harmonic frequency of the crystal frequency. Adjust R13 to give a clean signal. If no signal is present, check Q1, Q3 and CR14.
- (j) Repeat step (g).
- (k) Select a channel with an operating frequency of 26.75 to 30 MHz. Check for +24 volts on pin 37. If no voltage is present, check jumper connections (see paragraph 4.6 for details).
- (l) Repeat step (i) and then (g).

(7) RF STAGES A14 AND WIDEBAND AMPLIFIER A15

- (a) With the audio generator set to deliver a line 1 input as in paragraph (6)(a), select channel 1.

- (b) Check for the presence of an RF signal at terminal 2 of the channel 1 RF board. If no signal is observed, check Q1, Q2, T1, T2, T3 and T4 on A14.
- (c) Repeat steps (a) and (b) for channels 2 through 8 in turn.
- (d) Check for the presence of an RF signal at terminal 4 of wideband amplifier A15. If no signal is observed check Q401 and Q402 on A15.

5.3 REPAIR

In most cases, the repair of the SME-5 will consist of the replacement of an electrical component. The following precautions should be observed:

- (1) Replace a defective component with its exact duplicate.
- (2) Place a new component in the same position as the one it replaces. In general, do not change the existing chassis layout, whether in the routing of wiring or component placement.
- (3) Do not use a soldering iron with a power rating of more than 100 watts. Use a pair of long-nose pliers as a heat sink to protect components while soldering.
- (4) Exercise caution when replacing components of printed circuit boards. Excessive heat applied to a board might cause the printed wiring to lift off.
- (5) Double check any solder joints made. Cold or loose solder connections will cause trouble.

5.4 TUNING PROCEDURE FOR CHANGING OPERATING FREQUENCIES

- (1) With the power supply switched OFF, disconnect all external wiring from TB1, TB2 and TB3.
- (2) Disconnect the RF output cable from J128 and connect a 47 ohm, 1/2 watt resistor across J128.
- (3) Jumper terminal 7 of TB3 to ground.
- (4) Determine the frequencies of the new crystals required in the HF oscillator (A12), using the following equations:

- (a) for operating frequencies below 22 MHz

$$f_X = f_R + f_I$$

- (b) for operating frequencies above 22 MHz

$$f_X = f_R + f_I$$

where f_X = crystal frequency
 f_R = operating frequency
 $f_I = 1750$ KHz

5.5 ALIGNMENT PROCEDURE

(1) GENERAL

NOTE

Alignment procedure is described for model SME(RC)-5U/L. For models SME(RC)-5U and SME(RC)-5L, alignment is required for operation in the appropriate sideband only.

- (a) Disconnect all external wiring from TB1, TB2, TB3, J119 and J120.
- (b) Connect two jumper wires, one to terminal 9 of TB3, and other to terminal 7 of TB3.

(2) AUDIO CIRCUITS

(a) LINE AUDIO INPUT

- (1) Connect an AF signal generator to terminal 1 and 3 of TB1. Set output to 1 KHz at a level of 78 mv (-20 dbm).
- (2) Set the power switch to ON.
- (3) Turn USB switch to LINE 1. Rotate R6 on A20 and USB LEVEL control on front panel fully clockwise.
- (4) The VTVM connected across pin 1 and 2 of IF board A9 should indicate a level of 78 mv.
- (5) Turn USB switch to OFF and LSB switch to LINE 1.
- (6) Repeat step 3 and 4 above with LSB LEVEL control on front panel fully clockwise.
- (7) Repeat steps 1 to 6 above with AF generator connected to terminals 7 and 9 of TB1 and the sideband switches to LINE 2. In step 3 turn R7 on A20 fully clockwise.

(b) MICROPHONE AND CW INPUT

- (1) Turn USB switch to MIC/KEY and LSB switch to OFF. Turn MODE switch to AME, PILOT CARR or SUPP CARR.

- (2) Connect AF signal generator to terminal 5 of TB1. Set its output to 1 KHz at a level of -55 dbm as measured on an audio VTVM.
- (3) Connect an oscilloscope to gate 3 of A20Q2. Connect link 1 (CARBON MIC) to its terminals on AF board A20.
- (4) Adjust A20R14 for a maximum signal as measured on the oscilloscope.
- (5) Connect a dc voltmeter to TP1 on A20 and adjust A20R19 for a minimum reading on the voltmeter.
- (6) Connect an audio VTVM to pin 5 of A20. Adjust A20R33 for an output level of -20 dbm as measured on VTVM.
- (7) Adjust R19 on AF board A20 until the output, as measured in step (6) above just begins to drop.
- (8) Increase signal generator level. The output as measured on VTVM should remain constant at -20 dbm.
- (9) Remove oscilloscope from the gate of A20Q2 and connect it to pin 5 of A20.
- (10) Switch the signal generator off and then switch it on. The oscilloscope should indicate a spike in the output signal.
- (11) Repeat step (10) a few times while adjusting A20R37 until the spike in the output signal as noted on the oscilloscope is reduced to a minimum. Note that the output level as measured on the VTVM remains constant at -20 dbm.
- (12) Repeat steps (1) to (11) above with USB switch in the OFF position and LSB switch in the MIC/KEY position.
- (13) Remove signal generator and link 1 from its terminals.
- (14) Turn MODE switch to CW or MCW. Connect the other end of the jumper wire connected to pin 9 on TB3 to ground.
- (15) Adjust R20 on A20 for a level of -20 dbm as measured on VTVM connected to pin 5 of A20.
- (16) Repeat steps (13) to (15) above with LSB switch in the OFF position and USB switch in the MIC/KEY position.

(c) METER CALIBRATION

- (1) Set USB/LSB switch to LSB.
- (2) Adjust R5 on the meter board A7 for an indication of 0 on the red scale.

(3) IF BOARD A9

- (a) Turn LSB switch to LINE 2 and USB switch to its OFF position. Turn MODE switch to SUPP CARR.
- (b) Connect a two tone AF generator to terminal 7 and 9 of TB1. Adjust its level to give -20 dbm.
- (c) Connect an oscilloscope to pin 8 of IF board A9.
- (d) Adjust C1812 on A9 for maximum two tone output as measured on the oscilloscope.
- (e) Disconnect the AF generator. With the oscilloscope on its most sensitive range, adjust C1813 for a minimum signal.
- (f) Reconnect AF generator and note the two tone waveform on the oscilloscope. Distortion or jitters along the edge of the waveform is caused by carrier leakage and an improperly balanced bridge. Adjust R1813 and C1806 until the waveform is clean. Proper alignment will occur with R1813 approximately in mid-range.
- (g) Repeat step (f) above with LSB switch in OFF position and USB switch in LINE 2 position. Adjust R1814 and C1808 for a clean waveform.
- (h) Repeat steps (e), (f), and (g) above, until waveform is stable in both LSB and USB modes.
- (i) Readjust C1812 trimming for equal amplitude both in USB and LSB modes.
- (j) Turn USB switch to AME and LSB switch to OFF.
- (k) Switch the AF generator connected between terminals 7 and 9 of TB1 to give a single tone output.
- (l) Adjust R7 on the main chassis to give a clear two tone output. The envelope displayed on the oscilloscope should not be less than 400 mv peak to peak.
- (m) Repeat steps (j), (k), and (l) with LSB switch turned to AME and USB switch to OFF.
- (n) Turn MODE switch to PILOT CARR.

- (o) Connect a spectrum analyser to the output pin 8 of IF Board A9. Adjust R8 on the main chassis to give the appropriate level of carrier reinsertion as observed by the relative levels of two tones on the spectrum analyser.

(4) MIXER AND PROGRAMME BOARD A13 and RF CIRCUITS

NOTE

Before aligning the Mixer and Programme board, check that programming straps on the board are placed correctly. See principle of operation for strapping details.

- (a) Connect a 50 ohm resistive load to J128 (RF OUT) on the rear panel. Connect an oscilloscope across J128.
- (b) Select the channel that operates on the highest frequency. Connect the other end of the jumper wire attached to pin 7 on TB2 to ground.
- (c) Tune the transformers T1 through T4 on the selected card of RF amplifier A14 to the operating frequency (crystal frequency minus the IF frequency). Disconnect oscilloscope and connect a spectrum analyser across the output jack.
- (d) Adjust the spectrum analyser to monitor the crystal frequency. Adjust C27 and R29 on the mixer doubler board for minimum amplitude.
- (e) Connect oscilloscope across pin 39 of mixer doubler board A13 and adjust R18 on the main chassis for a level of 50 mv input signal as indicated on the oscilloscope.
- (f) Connect oscilloscope and a VTVM across J128. Repeat step (c) and (d) above for the remaining channels, adjusting the potentiometer on each selected card of RF amplifier A14 to obtain an RF output of 2.2V RMS.
- (g) With the spectrum analyser adjusted to monitor the operating frequency, adjust R4 on the wide band amplifier A15 for best intermodulation distortion.

(5) HF OVEN A12

- (a) Set the power to ON and allow a one hour warm-up period.
- (b) Connect a frequency counter across pin 34 of A13.
- (c) Select channel 1 and adjust the capacitor corresponding to that channel on the HF oven board A12 for a frequency counter reading of the selected crystal frequency within ± 5 Hz.
- (d) Repeat step (c) above for the remaining channels.

(6) EXTENDED MODE AND CHANNEL SELECT A11

- (a) TERMINATE RF OUT connector in two resistors; 47 ohms and 3 ohms connected in series, 3 ohms resistor going to ground.
- (b) Connects a spectrum analyser between the two resistors.
- (c) Turn CHANNEL SELECT switch to REMOTE.
- (d) Apply a ground to pin K on J119. Adjust R20 on A11 until the reinserted carrier, as observed on the spectrum analyser, has the desired value (-20 db below the level of audio tone).
- (e) Remove ground from pin K and connect it to pin L on J119. Adjust R21 on A11 for the same level as audio tone.

(7) VOX/ANTI VOX BOARD A3

- (a) Set S11 on the rear panel to VOX LSB.
- (b) Set LSB switch on the front panel to MIC/KEY and USB switch to OFF. Connect headphone audio to the ANTI-VOX input (pin 9 on TB3).

NOTE

If there is no receive audio, connect an AF generator to pin 9 on TB3 and set its level to the expected level of the receive audio.

- (c) Turn the ANTI-VOX control on the front panel to its minimum position. Speak into the microphone and adjust the VOX gain control on the front panel until relay K1 energizes. Adjust R8 on A3 until relay K1 does not de-energize during normal pauses between words.
- (d) Adjust ANTI-VOX control on the front panel until relay K1 does not pull in when speaking at a normal level into the microphone.

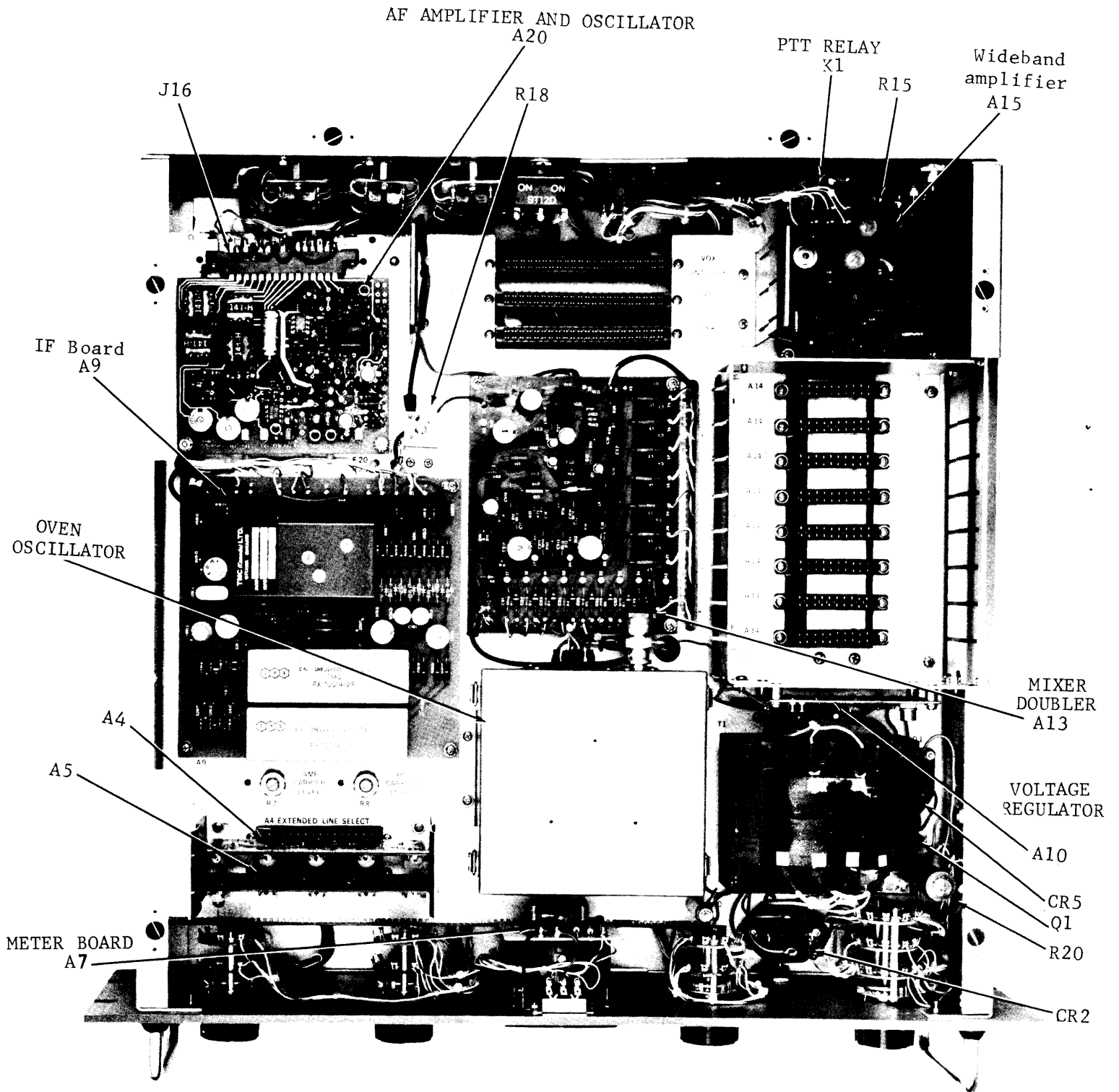

Figure 5-1 SME-5 top cover removed

TIME DELAY
R8, C12

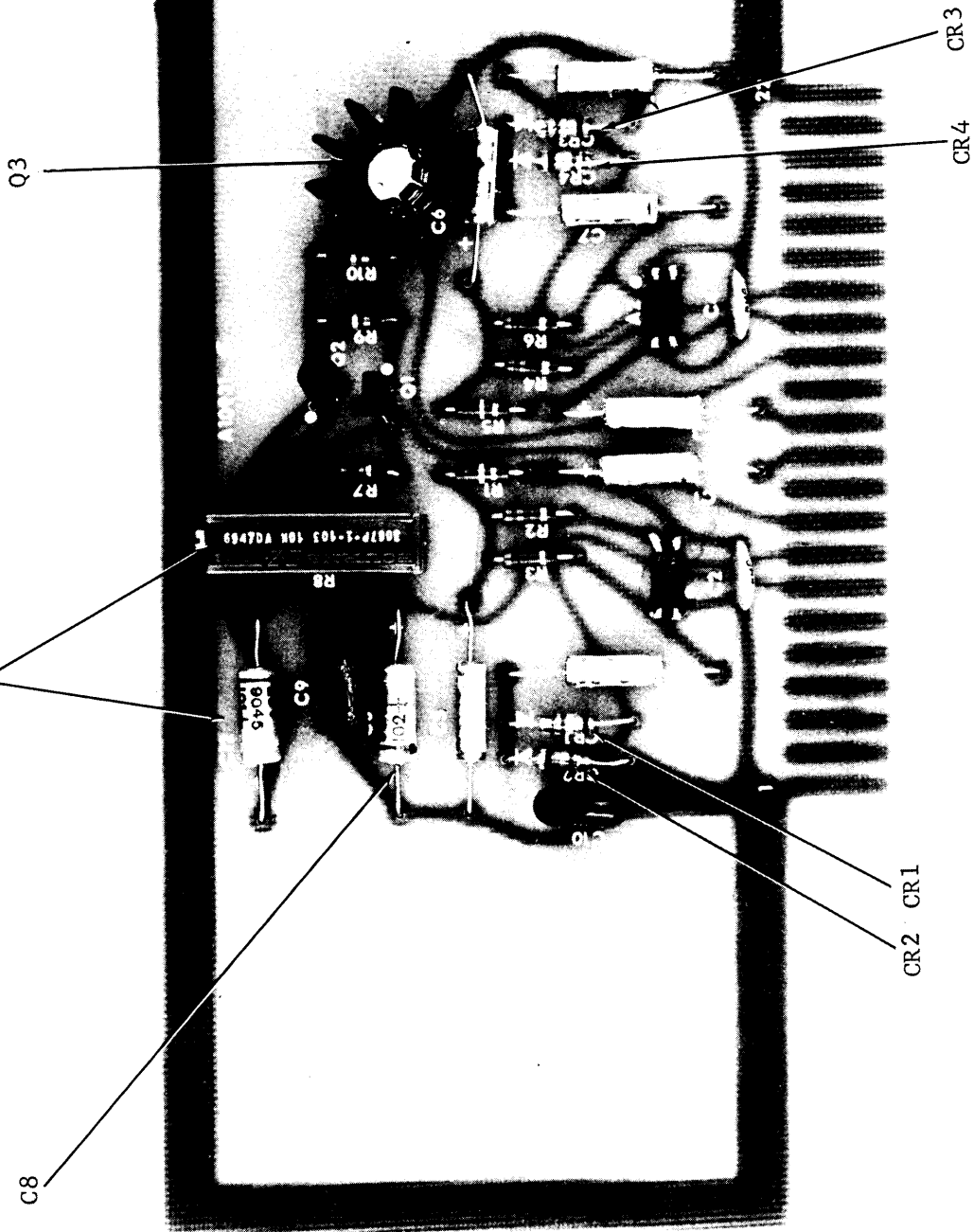

Figure 5-3 VOX/ANTI-VOX board A3 parts location

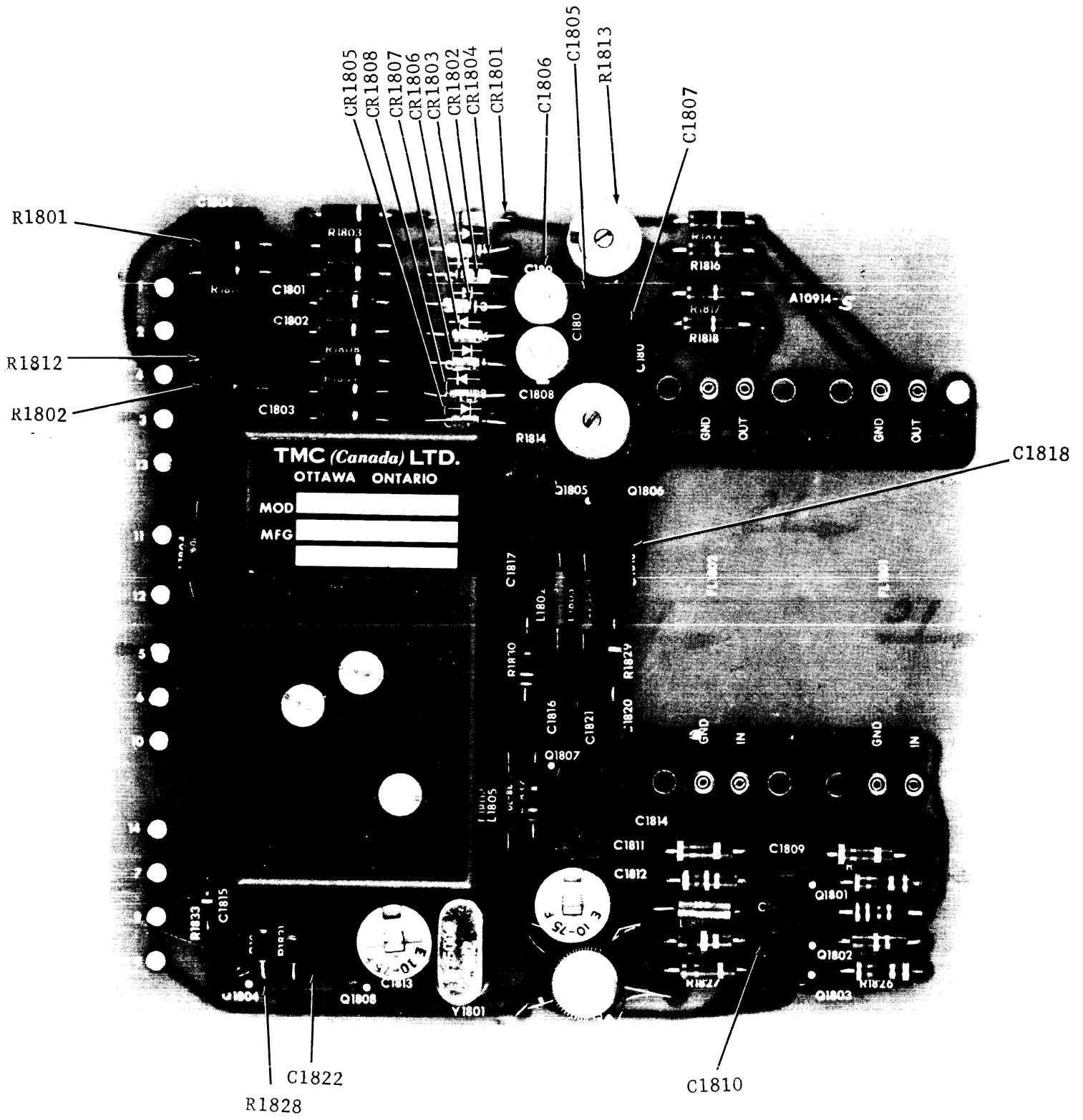

Figure 5-4 XMIT IF board A9 parts location

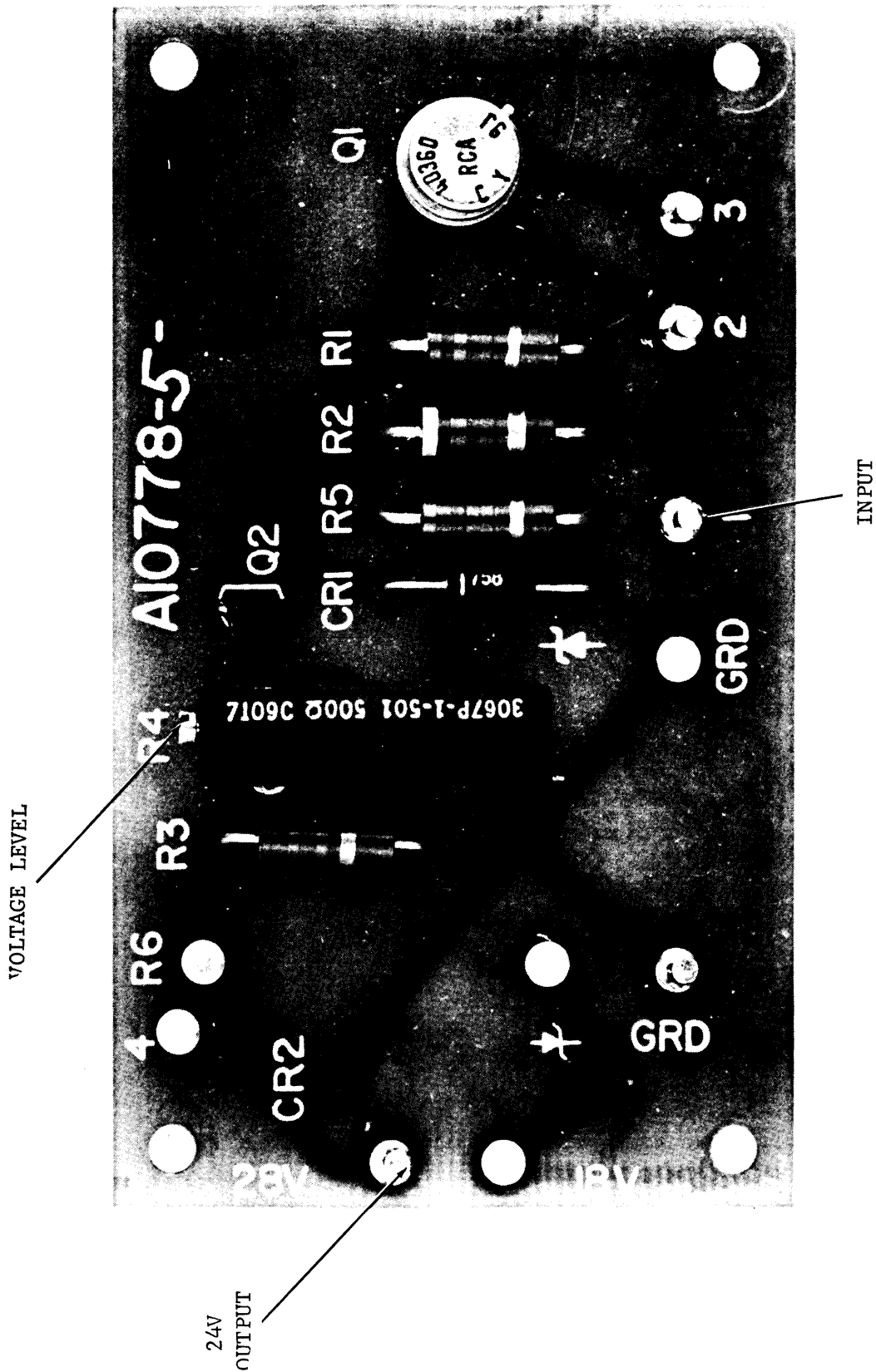

Figure 5-5 Regulator board A10 parts location

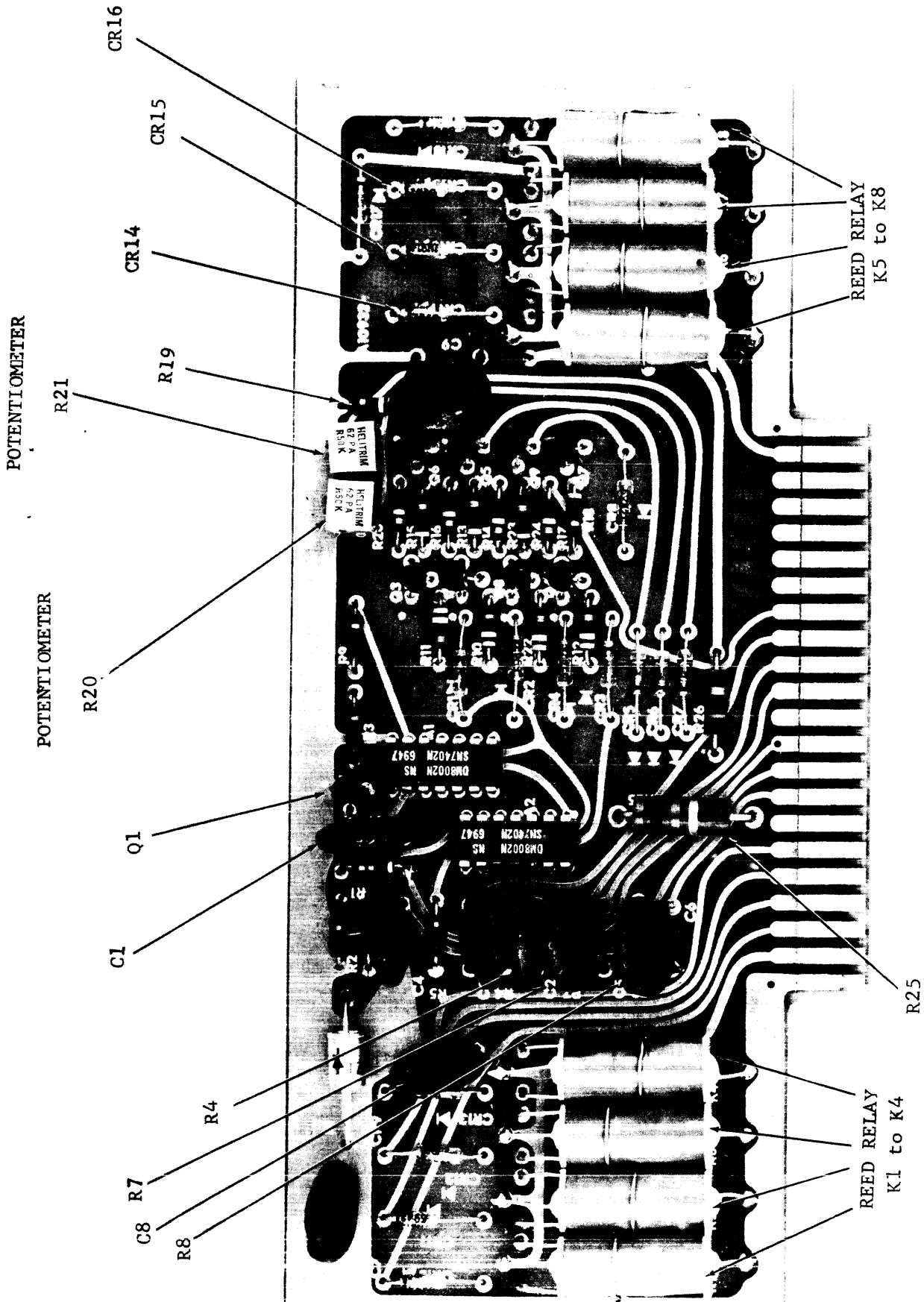

Figure 5-6 Extended mode and channel select board All parts location

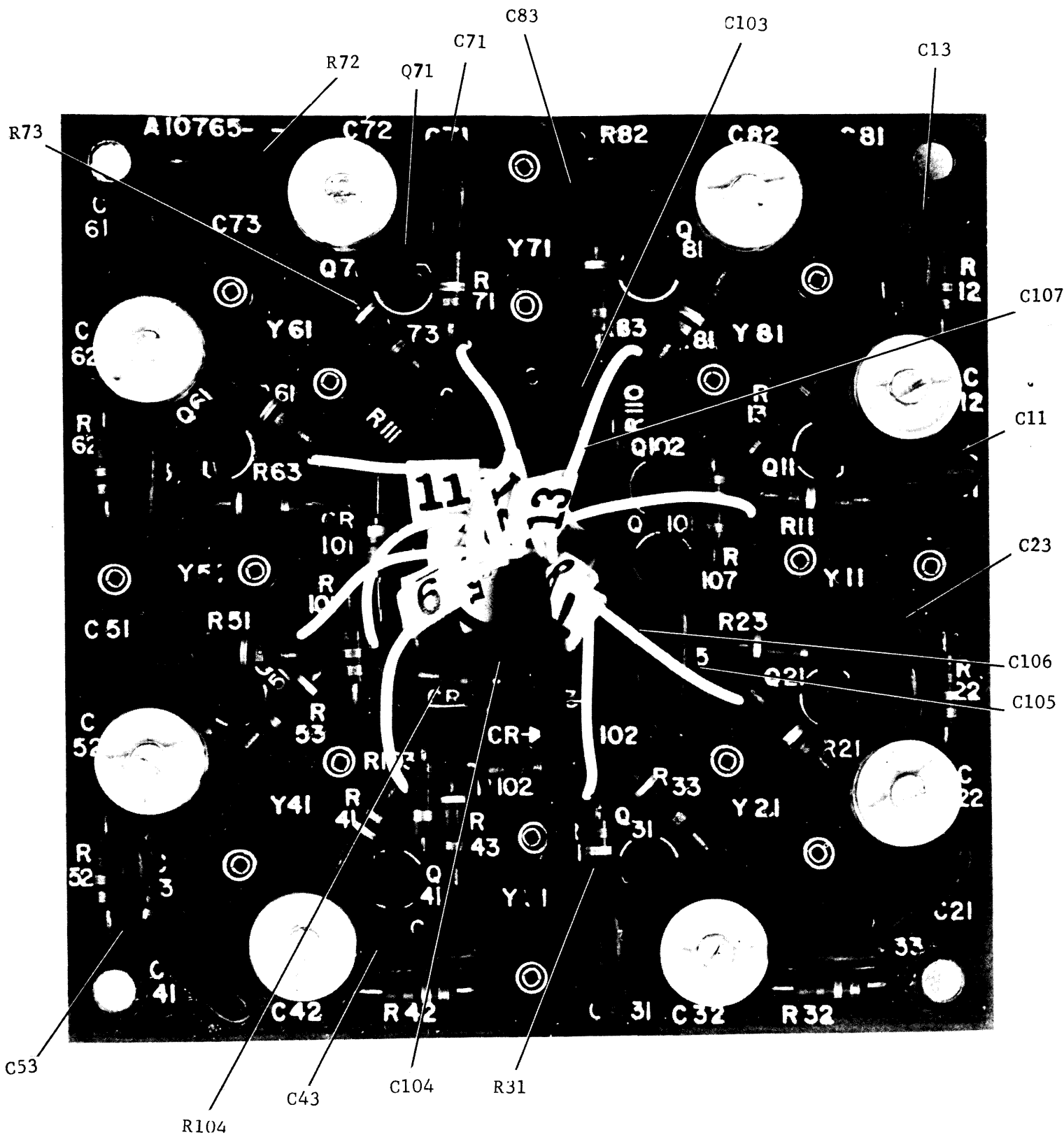

Figure 5-7 HF oscillator A12 parts location

HEATER TRANSISTOR Q103



THERMISTOR RVT 101

Figure 5-8 Oven control assembly A12A1 parts location

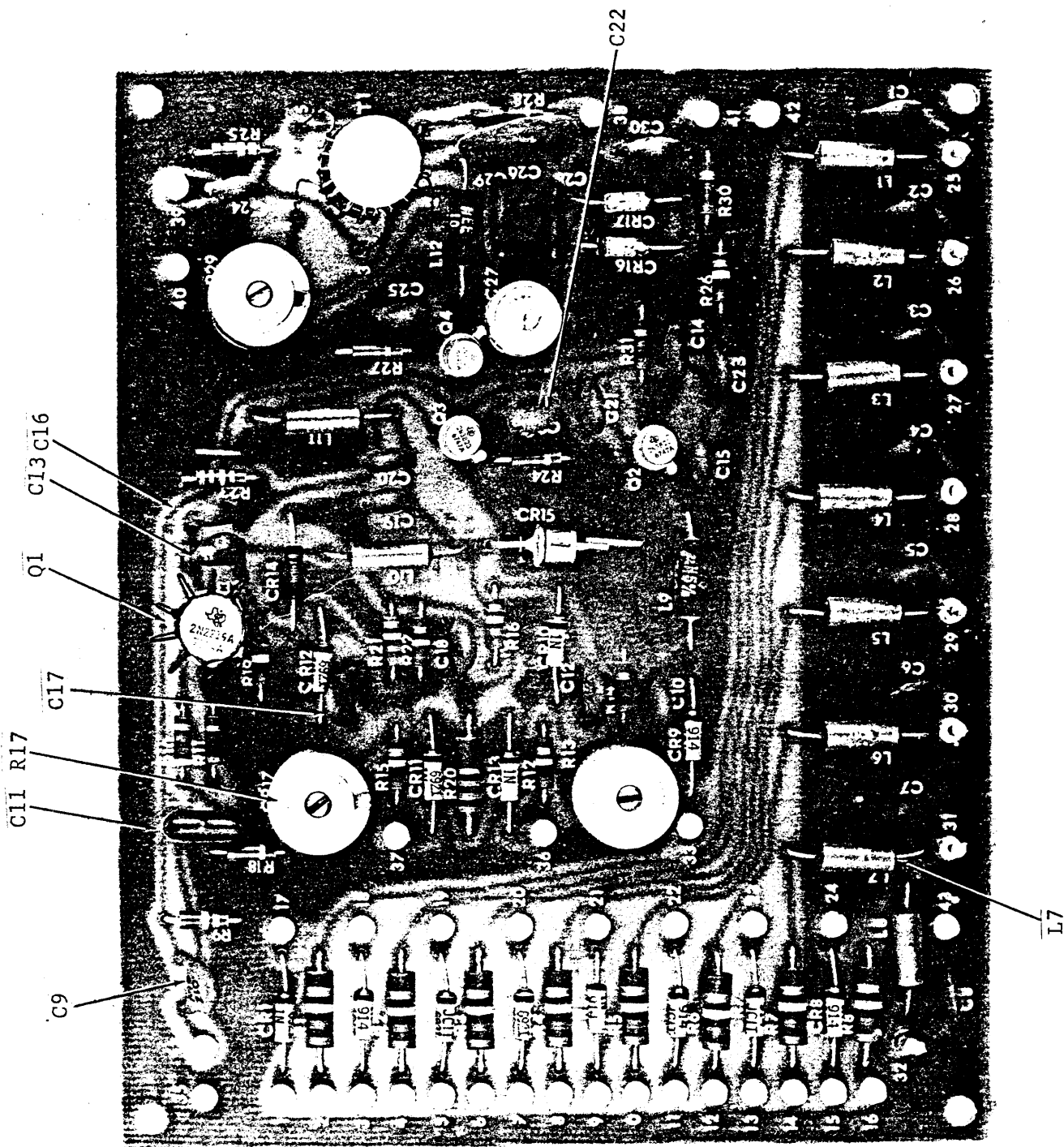

Figure 5-9 Mixer-doubler A13 parts location

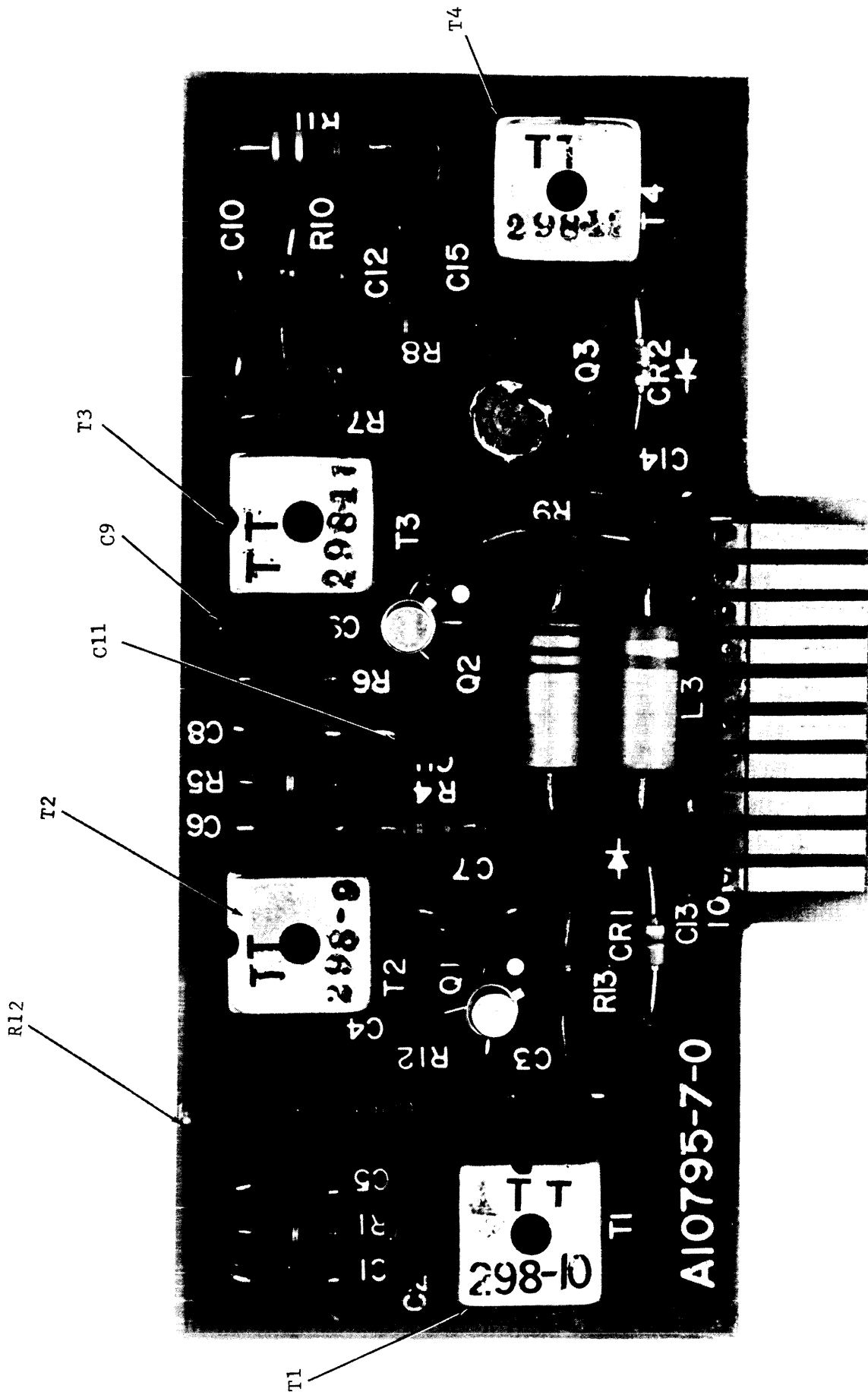

Figure 5-10 RF amplifier A14 parts location

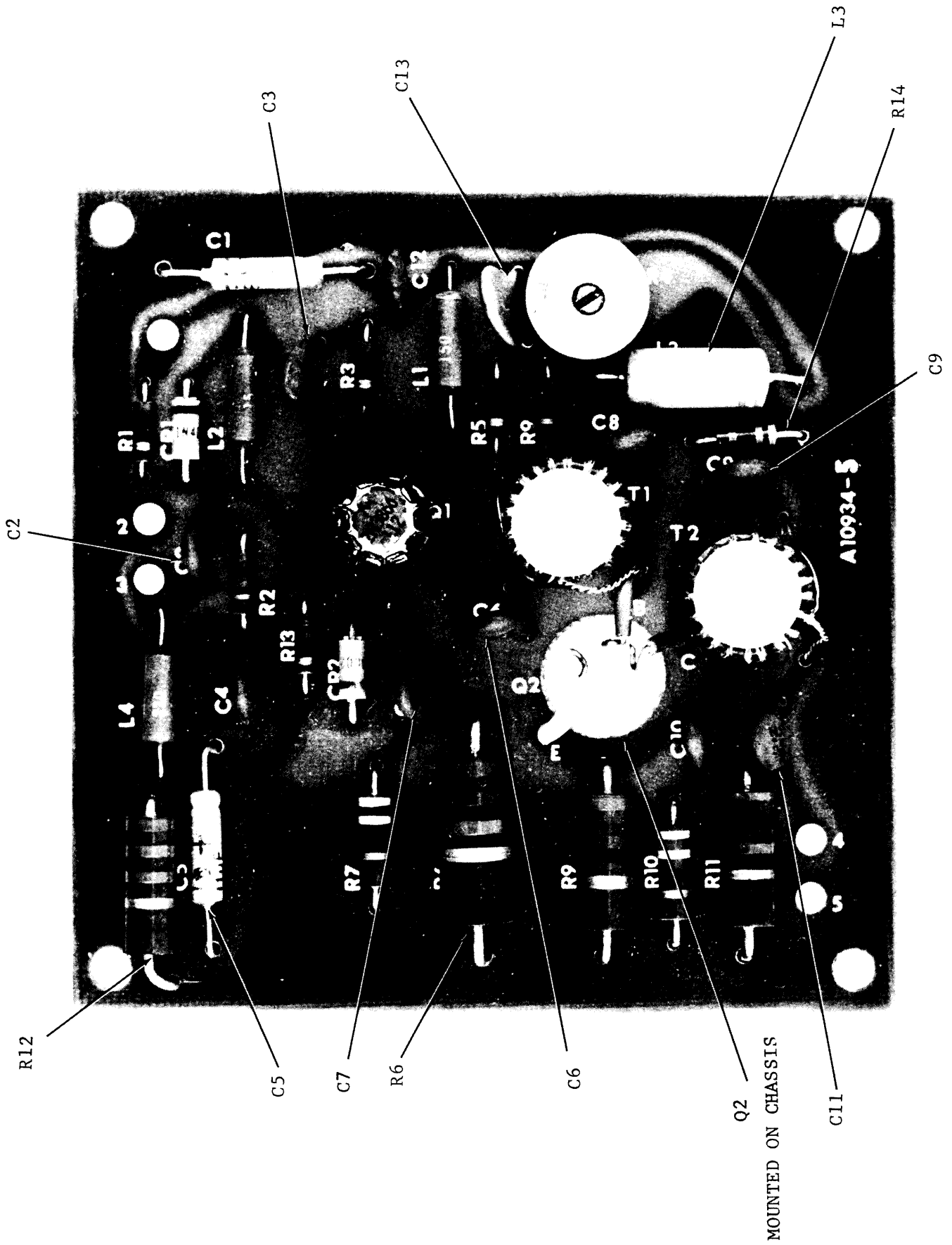

Figure 5-11 Wideband amplifier A15 parts location

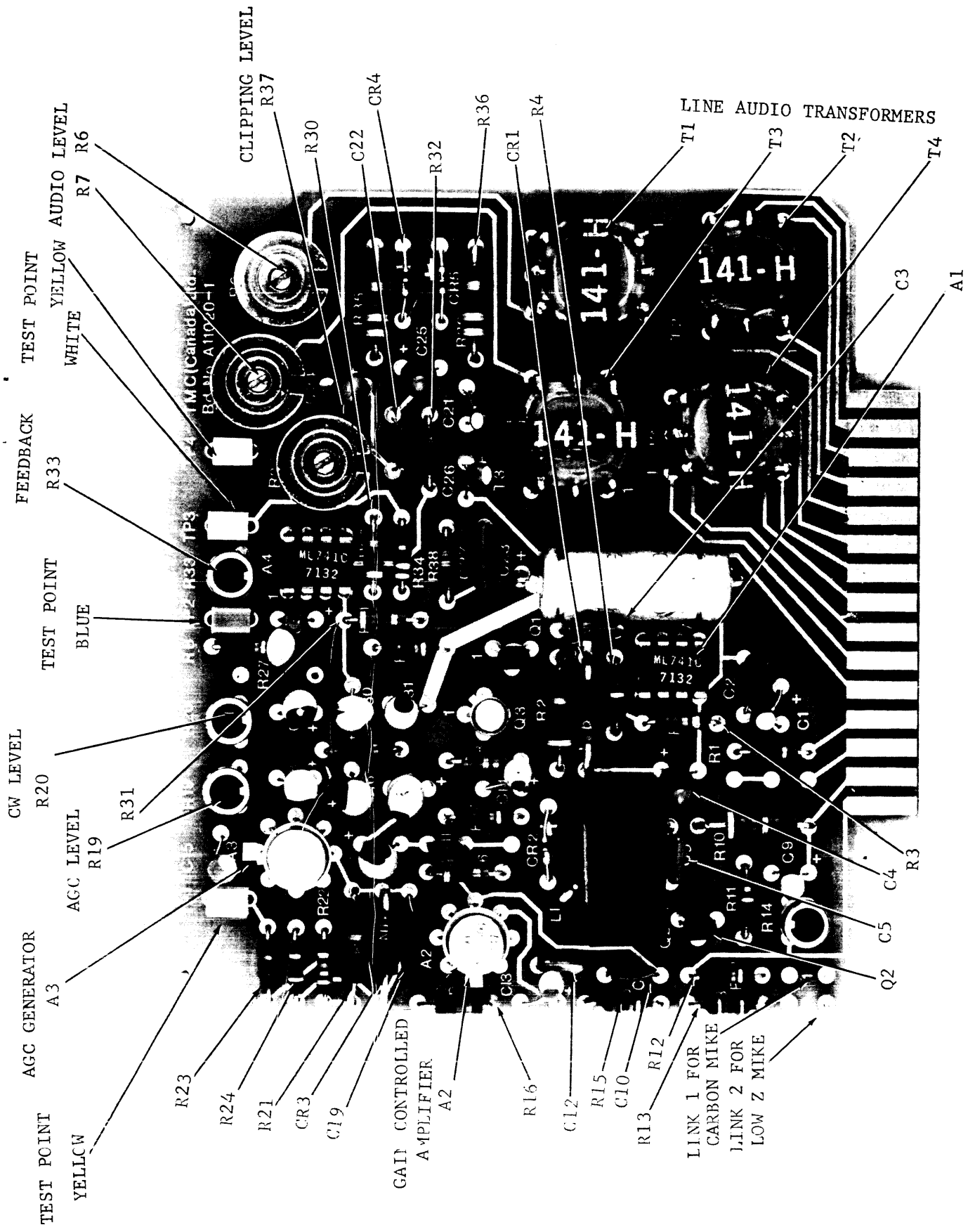

Figure 5-12 AF amplifier and oscillator A20 parts location

SECTION 6

PARTS LIST

6-1 INTRODUCTION

Reference designations have been assigned to identify all electrical parts. These designations are marked on the equipment adjacent to the parts that they identify and are included on all drawings, diagrams and part lists. The letters of a reference designation indicate the generic group of the part, such as capacitor, resistor, transistor, etc. The numeral differentiates between parts of the same generic group. Sockets associated with any particular plug-in device, such as a transistor or fuse, are identified by a reference designation which incorporates the designation used for that device as well as a prefix symbol. To expedite delivery when ordering replacement parts, specify the TMC part number and the name and model number of the equipment.

MAIN CHASSIS

REF SYMBOL	DESCRIPTION	TMC PART NUMBER
A1	PRINTED CIRCUIT BOARD: FSK	A10933-5
A3	PRINTED CIRCUIT BOARD: VOX/ANTI-VOX	A10931-5
A4	PRINTED CIRCUIT BOARD: LSB extended line select	A10962-5
A5	PRINTED CIRCUIT BOARD: USB extended line select	Same as A4
A7	PRINTED CIRCUIT BOARD: Meter	A10992-5
A9	PRINTED CIRCUIT BOARD: IF	A10914-5
A10	PRINTED CIRCUIT BOARD: Regulator Voltage	A10778-5
A11	PRINTED CIRCUIT BOARD: Extended mode and channel select	A10932-5
A12	PRINTED CIRCUIT BOARD: HF oscillator	A0-10006
A13	PRINTED CIRCUIT BOARD: Mixer-Doubler	A10900-5
A14	PRINTED CIRCUIT BOARDS: RF Amplifier	A10795-6 to 18
A15	PRINTED CIRCUIT BOARD: Wide band amplifier	A10934-5
A17	PRINTED CIRCUIT BOARD: Input filter	A10975-5
A18	PRINTED CIRCUIT BOARD: Input filter	A10976-5
A19	PRINTED CIRCUIT BOARD: Input filter	A10977-5
A20	PRINTED CIRCUIT BOARD: AF amplifier and oscillator	A11020-5
C2, C3, C4	CAPACITOR: elec, 1500 uF, 40W VDC, polar	CE10011
C5	CAPACITOR: flat, foil, 20uf, $\pm 5\%$, 150VDC	CC10011-16
C6, C7	CAPACITOR: fixed ceramic	CC100-32

REF SYMBOL	DESCRIPTION	TMC PART NUMBER
CR1	DIODE	1N538
CR2	DIODE, network	NW10007
CR3	DIODE	1N914
CR4	Same as CR3	
CR5	DIODE, Zener, 12V, 10W	1N2976
CR6, CR7	DIODE	1N538
DS1	LAMP: incand, 28V, 0.04 amp	B1110-7
DS2	Same as DS1	
F1	FUSE: slo-blo, 115 VAC, 1 amp	FU102-1
* F2	FUSE: slo-blo, 235 VAC, 0.5 amp	FU102-0.5
J1	CONNECTOR: PC Bd, 15 contact	JJ10010-015-01-101
J2	Same as J1	
J3	CONNECTOR: PC Bd, 22 contact	JJ319-22DPE
J4, J5	Same as J3	
J6	CONNECTOR: PC Bd, 10 contact	JJ10010-010-01-101
J7 THRU J13	Same as J6	
J14	CONNECTOR	MS3102A-16S-5P
J15	CONNECTOR: RF	UG625B/2U
J16	CONNECTOR: PC Bd, 15 contact	JJ319A-15DPE
J119	CONNECTOR: 22 Pin	MS3102-28-11P
J120	CONNECTOR: 14 Pin	MS3102-20-27 P
J126 THRU		
J128	Same as J15	

* Required for 230 vac operation only

REF SYMBOL	DESCRIPTION	TMC PART NUMBER
K1, K2	RELAY: arm 24 VDC	RL116DC3C24A
L1, L2	COIL: rf	CL240-120
M1	METER: audio, special	MR194
Q1	TRANSISTOR	2N3055
Q2	TRANSISTOR	2N3375
R3	RESISTOR: var, comp, 10K ohms, <u>+10%</u> , $\frac{1}{2}$ W	RV106UX10C103A
R4	Same as R3	
R7	RESISTOR: var, comp, 50K ohms, <u>+10%</u>	RV4LAYS503A
R8	Same as R7	
R9	RESISTOR: fxd, comp, 270 ohms, <u>+5%</u> , $\frac{1}{2}$ W	RC20GF271J
R10	RESISTOR: fxd, w/w, 3 ohms, 5W	RW107-4
R12	RESISTOR: var, comp, 250 K ohms, <u>+10%</u>	RV4NAYSA254AYY
R13	RESISTOR: var, comp, 10 K ohms, <u>+10%</u>	RV4NAYSA103AYY
R15	RESISTOR: fxd, comp, 100 ohms, <u>+5%</u> , 1W	RC32GF101J
R16	RESISTOR: fxd, comp, 100 ohms, <u>+5%</u> , $\frac{1}{2}$ W	RC20GF101J
R18	RESISTOR: var, comp, 50 ohms, <u>+10%</u> , $\frac{1}{4}$ W	RV106UX8B500A
R19	RESISTOR: var, comp, 50 K ohms, <u>+10%</u>	RV4LAYS503A
R20	RESISTOR: fxd, w/w, 25 ohms, 25W	RW111-6
R21	RESISTOR: fxd, comp, 470 ohms, <u>+5%</u> , $\frac{1}{2}$ W	RC20GF471J

REF SYMBOL	DESCRIPTION	TMC PART NUMBER
S1	SWITCH: rotary, special	SW10059
S2, S3	Same as S1	
S4	SWITCH: rotary, special	SW10063
S7	SWITCH: toggle, single pole	ST12D
S8	SWITCH: toggle, double pole	ST22N
S9	SWITCH: slide, double pole	SW163
S10	SWITCH: toggle, double pole	ST22K
S11	Same as S7	
T1	TRANSFORMER: power	TF10071
TB1	TERMINAL STRIP: barrier, lug	TM100-9
TB2 THRU TB3	Same as TB1	
XF1	HOLDER: fuse	FH100-1
XF2	Same as XF1	
XDS1	LIGHT INDICATOR: sub-mini, yellow	TS153-3
XDS2	LIGHT INDICATOR: sub-mini, white	TS153-5
XQ1	SOCKET: semi-conductor	TS166-1

A1, FREQUENCY SHIFT KEYER ASSEMBLY

TMC PART NO. A10933-5

REF SYMBOL	DESCRIPTION	TMC PART NUMBER
A1	INTEGRATED CIRCUIT	NW10012
A2	INTEGRATED CIRCUIT	MC7400P
A3	INTEGRATED CIRCUIT	MC7490P
A4, A5	Same as A3	
A6	INTEGRATED CIRCUIT	CA3020
C1	CAPACITOR: fxd, cer, 0.47 uF 50W VDC	CC10026-17
C2	CAPACITOR: fxd, cer, 0.1 uF, 50W VDC	CC10026-10
C3	CAPACITOR: fxd, cer, 0.02 uF, 50W VDC	CC10026-8
C4	CAPACITOR: fxd, cer, 0.02 uF, +80% -20%, 25W VDC	CC100-40
C5	Same as C4	
C6	CAPACITOR: fxd, mica, 56 pF, <u>+5%</u> , 500W VDC	CM111E560J5S
C7	Same as C6	
C8	CAPACITOR: fxd, mica, 240 pF, <u>+5%</u> , 500W VDC	CM111E241J5S
C9	Same as C8	
C10	CAPACITOR: fxd, cer, 0.01 uF, +80% -20%, 25W VDC	CC100-41
C11	Same as C10	
C12	CAPACITOR: fxd, cer, 0.1 uF, +80% -20%, 25W VDC	CC100-44
C13	Same as C12	
C14, C15	Same as C10	

REF SYMBOL	DESCRIPTION	TMC PART NUMBER
C16	CAPACITOR: fxd, cer, 2.2 uF, 50W VDC	CC10026-21
C17	CAPACITOR: fxd, cer, 1.0 uF, 50W VDC	CC10026-19
C18	Same as C12	
C19	Same as C4	
C20	CAPACITOR: fxd, cer, 0.2 uF, +80% -20%, 25W VDC	CC100-33
C21	Same as C12	
CR1	DIODE	1N914
CR2	Same as CR1	
CR3	DIODE: Zener, 7.5 V, 400 mW	1N755
CR 4 THRU CR 9	Same as CR1	
CR10	DIODE: Zener, 5.1 V, 5W	1N5338
CR11 THRU CR14	DIODE	1N34A
L1	COIL: RF, fxd, 10 mH	CL101-4
L2, L3	COIL: RF, fxd, 1.0 mH	CL101-2
Q1	TRANSISTOR	2N3904
Q2	TRANSISTOR	2N3823
Q3	Same as Q2	
Q4	TRANSISTOR	2N5361
Q5	Same as Q1	
Q6	Same as Q4	
Q7, Q8	Same as Q1	
R1	RESISTOR: fxd, comp, 2.2 K ohms, +5%, 1/4W	RC07GF222J

REF SYMBOL	DESCRIPTION	TMC PART NUMBER
R2	RESISTOR: fxd, comp, 9.1 K ohms, $\pm 5\%$, $\frac{1}{2}W$	RC20GF912J
R3	RESISTOR: fxd, comp, 3.9 K ohms, $\pm 5\%$, $\frac{1}{2}W$	RC20GF392J
R4	RESISTOR: fxd, comp, 12 K ohms, $\pm 5\%$, $\frac{1}{2}W$	RC07GF123J
R5	RESISTOR: fxd, comp, 8.2 K ohms, $\pm 5\%$, $\frac{1}{2}W$	RC07GF822J
R6	RESISTOR: fxd, comp, 1.5 K ohms, $\pm 5\%$, $\frac{1}{2}W$	RC07GF152J
R7	RESISTOR: fxd, comp, 1 K, ohms, $\pm 5\%$, $\frac{1}{2}W$	RC20GF102J
R8	RESISTOR: fxd, comp, 330 ohms, $\pm 5\%$, 2W	RC42GF331J
R9	RESISTOR: fxd, comp, 120 ohms, $\pm 5\%$, $\frac{1}{2}W$	RC20GF121J
R10	RESISTOR: fxd, comp, 22 K ohms, $\pm 5\%$, $\frac{1}{2}W$	RC07GF223J
R11	Same as R10	
R12	RESISTOR: fxd, comp, 1 K ohms, $\pm 5\%$, $\frac{1}{2}W$	RC07GF102J
R13	RESISTOR: fxd, comp, 47 K ohms, $\pm 5\%$, $\frac{1}{4}W$	RC07GF473J
R14	RESISTOR: fxd, comp, 10 K ohms, $\pm 5\%$, $\frac{1}{2}W$	RC07GF103J
R15	Same as R1	
R16	Same as R13	
R17	Same as R14	
R18	RESISTOR: fxd, comp, 1.8 K ohms, $\pm 5\%$, $\frac{1}{2}W$	RC07GF182J

REF SYMBOL	DESCRIPTION	TMC PART NUMBER
R19 THRU R21	Same as R18	
R22, R23	Same as R1	
R24	RESISTOR: fxd, comp, 2.7 K ohms, $\pm 5\%$, $\frac{1}{2}W$	RC07GF272J
R25	Same as R24	
R26	RESISTOR: fxd, comp, 620 ohms, $\pm 5\%$, $\frac{1}{2}W$	RC07GF621J
R27	RESISTOR: fxd, comp, 820 ohms, $\pm 5\%$, $\frac{1}{2}W$	RC07GF821J
R28	RESISTOR: fxd, comp, 510 K ohms, $\pm 5\%$, $\frac{1}{2}W$	RC07GF514J
R29	RESISTOR: fxd, comp, 1 ohm, $\pm 5\%$, $\frac{1}{2}W$	RC07GF1R0J
R30	RESISTOR: var, comp, 5 K ohms, $\frac{1}{2}W$	RV124-1-502
R31	RESISTOR: fxd, comp, 6.8 K ohms, $\pm 5\%$, $\frac{1}{2}W$	RC07GF682J
R32	RESISTOR: fxd, comp, 330 ohms, $\pm 5\%$, $\frac{1}{2}W$	RC07GF331J
T1	TRANSFORMER: audio	TF246-17Z
T2	TRANSFORMER: audio	TF10037
T3	TRANSFORMER: audio	TF10077
Y1	CRYSTAL	CR18A/U
Y2	Same as Y1	

A3, VOX/ANTI-VOX ASSEMBLY
TMC PART NO. A10931-5

REF SYMBOL	DESCRIPTION	TMC PART NUMBER
A1	INTEGRATED CIRCUIT	MFC4010P
A2	Same as A1	
C1	CAPACITOR: elec, 1 uF, 15 WVDC, polar	CE105-1-15
C2	CAPACITOR: fxd, cer, 0.01 uF, +80% -20%, 25W VDC	CC100-41
C3	Same as C1	
C4	Same as C2	
C5, C6, C7	Same as C1	
C8	CAPACITOR: elec, 10 uF, 15W VDC, polar	CE105-10-15
C9	CAPACITOR: fxd, cer, 0.2 uF, +80% -20%, 25W VDC	CC100-33
C10	CAPACITOR: fxd, cer, 820 pF	CM111E821J5S
C11	Same as C1	
C12	Same as C8	
C13	Same as C1	
CR1	DIODE	1N34A
CR2, CR3, CR4	Same as CR1	
Q1	TRANSISTOR	2N3904
Q2	TRANSISTOR	2N3906
Q3	TRANSISTOR	2N2219A
R1	RESISTOR: fxd, comp, 220 K ohms, $\pm 5\%$, $\frac{1}{2}W$	RC07GF224J
R2	RESISTOR: fxd, comp, 1.8 K ohms, $\pm 5\%$, $\frac{1}{2}W$	RC07GF182J

REF SYMBOL	DESCRIPTION	TMC PART NUMBER
R3	RESISTOR: fxd, comp, 8.2 K ohms, <u>+5%</u> , $\frac{1}{2}$ W	RC07GF822J
R4	Same as R2	
R5	Same as R1	
R6	Same as R3	
R7	RESISTOR: fxd, comp, 1 K ohms, <u>+5%</u> , $\frac{1}{2}$ W	RC07GF102J
R8	RESISTOR: var, w/w, 10 K ohms, $\frac{1}{2}$ W	RV10005-7P
R9	RESISTOR: fxd, comp, 10K ohms, <u>+5%</u> , $\frac{1}{2}$ W	RC07GF103J
R10	RESISTOR: fxd, comp, 22 K ohms, $\frac{1}{2}$ W	RC07GF223J

A4, A5, EXTENDED LINE SELECT ASSEMBLY
TMC PART NO. A10962

REF SYMBOL	DESCRIPTION	TMC PART NUMBER
CR1 THRU CR14	DIODE	1N914B
K1 THRU K4	RELAY	RL10039
K5	RELAY	RL10040

A7, METERING BOARD
TMC PART NO. A10992-5

REF SYMBOL	DESCRIPTION	TMC PART NUMBER
C1	CAPACITOR: fxd, elec, mini, 2 uF, 15 WVDC	CE105-2-15
C2	Same as C1	
C3	CAPACITOR: fxd, elec, mini, 25 uF, 15WVDC	CE105-25-15
CR1	DIODE	1N34A
CR2	Same as CR1	
Q1	TRANSISTOR	2N3904
R1	RESISTOR: fxd, comp, 100 K, ohms, $\pm 5\%$, $\frac{1}{4}W$	RC07GF104J
R2	RESISTOR: fxd, comp, 2.2 K, ohms, $\pm 5\%$, $\frac{1}{4}W$	RC07GF222J
R3	RESISTOR: fxd, comp, 15 K, ohms, $\pm 5\%$, $\frac{1}{4}W$	RC07GF153J
R4	RESISTOR: fxd, comp, 120 ohms, $\pm 5\%$, $\frac{1}{4}W$	RC07GF121J
R5	RESISTOR: var, w/w. 10 K ohms	RV10005-7P

A9, TRANSMITTER IF BOARD

TMC PART NO. A10914-5

REF SYMBOL	DESCRIPTION	TMC PART NUMBER
C1801	CAPACITOR: fxd, cer, .01 uF, 500W VDC	CC100-16
C1802 THRU C1804	Same as C1801	
C1805	CAPACITOR: fxd, mica, 22 pF, <u>+5%</u> , 500W VDC	CM111C220J1S
C1806	CAPACITOR: var, cer, 9-35 pF, 100W VDC	CV112-2
C1807	Same as C1805	
C1808	Same as C1806	
C1809	CAPACITOR: fxd, mica, 1000 pF, <u>+5%</u> , 500 W VDC	CM111C102J1S
C1810	Same as C1809	
C1811	CAPACITOR: fxd, mica, 47 pF, <u>+5%</u> , 500W VDC	CM111C470J1S
C1812	CAPACITOR: var, cer, 10-75 pF, 350W VDC	CV109-8
C1813	Same as C1812	
C1814	CAPACITOR: fxd, cer, 0.2 uF, <u>+80%</u> <u>-20%</u> , 25W VDC	CC100-33
C1815	Same as C1809	
C1816	Same as C1801	
C1817, C1818	Same as C1809	
C1819	Same as C1814	
C1820	Same as C1809	
CR1801 THRU CR1808	DIODE	1N34A
FL1801	FILTER, USB: 1750.3-1753.0 KHz	FX10014-1F

REF SYMBOL	DESCRIPTION	TMC PART NUMBER
FL1802	FILTER, LSB: 1747.0-1749.7 KHz	FX10014-2F
L1801 THRU L1805	COIL, RF: fxd, 1000 uH	CL275-102
Q1801 THRU Q1803	TRANSISTOR	2N3904
Q1804 THRU Q1808	TRANSISTOR	2N5459
R1801 THRU R1812	RESISTOR: fxd, comp, 1K ohms, $\pm 5\%$, $\frac{1}{2}W$	RC20GF102J
R1813	RESISTOR: var, comp, 500 ohms, $\pm 10\%$	RV111U501A
R1814	Same as R1813	
R1815 THRU R1818	RESISTOR: fxd, comp, 10 ohms, $\pm 5\%$, $\frac{1}{2}W$	RC20GF100J
R1819	RESISTOR: fxd, comp, 4.7 K ohms, $\pm 5\%$, $\frac{1}{2}W$	RC20GF472J
R1820	Same as R1819	
R1821	RESISTOR: fxd, comp, 470 K ohms, $\pm 5\%$, $\frac{1}{2}W$	RC20GF474J
R1822	RESISTOR: fxd, comp, 47 ohms, $\pm 5\%$, $\frac{1}{2}W$	RC20GF470J
R1823	RESISTOR: fxd, comp, 100 K ohms, $\pm 5\%$, $\frac{1}{2}W$	RC20GF104J
R1824	RESISTOR: fxd, comp, 15 K ohms, $\pm 5\%$, $\frac{1}{2}W$	RC20GF153J
R1825	RESISTOR: fxd, comp, 3.3 K ohms, $\pm 5\%$, $\frac{1}{2}W$	RC20GF332J
R1826	Same as R1822	
R1827	RESISTOR: fxd, comp, 6.8 K ohms, $\pm 5\%$, $\frac{1}{2}W$	RC20GF682J

REF SYMBOL	DESCRIPTION	TMC PART NUMBER
R1828	Same as R1815	
R1829	Same as R1801	
R1830	Same as R1825	
R1831	Same as R1824	
R1832	RESISTOR: fxd, comp, 330 ohms, +5%, $\frac{1}{2}$ W	RC20GF331J
R1833	RESISTOR: fxd, comp, 100 ohms, <u>+5%</u> , $\frac{1}{2}$ W	RC07GF101J
T1801	TRANSFORMER: RF	TZ10001
Y1801	CRYSTAL: 1.75 MHz	CR10008-1.750000

A10, REGULATOR BOARD

TMC PART NO. A10778-5

REF SYMBOL	DESCRIPTION	TMC PART NUMBER
CR1	DIODE: Zener, 10.0V, 400mW, 5%	1N758A
Q1	TRANSISTOR	TX10001
Q2	TRANSISTOR	2N3904
R1	RESISTOR: fxd, comp, 1.8 K ohms, +5%, $\frac{1}{2}$ W	RC20GF182J
R2	RESISTOR: fxd, comp, 4.7 K ohms, <u>+5%</u> , $\frac{1}{2}$ W	RC20GF472J
R3	RESISTOR: fxd, comp, 2.7 K ohms, <u>+5%</u> , $\frac{1}{2}$ W	RC20GF272J
R4	RESISTOR: var, w/w, 500 ohms,	RV10005-3P
R5	RESISTOR: fxd, comp, 1.5 K ohms, <u>+5%</u> , $\frac{1}{2}$ W	RC20GF152J

A11 EXTENDED MODE & CHANNEL SELECT ASSEMBLY

TMC PART NO. A10932-5

REF SYMBOL	DESCRIPTION	TMC PART NUMBER
A1	INTEGRATED CIRCUIT	SN7402P
A2	Same as A1	
C1 THRU C9	CAPACITOR: fxd, cer, 200,000 pF, +80% -20%, 25W VDC	CC100-33
CR1 THRU CR8	DIODE	1N914
CR9	DIODE: Zener, 5.1V, <u>+1%</u> , 1W	1N3826 Special
CR10 THRU CR18	Same as CR1	
K1 THRU K8	RELAY	RL10039
Q1 THRU Q4	TRANSISTOR	2N3904
Q5	TRANSISTOR	2N3906
Q6, Q7	Same as Q5	
Q8	Same as Q1	
Q9	Same as Q5	
R1	RESISTOR: fxd, comp, 47 K ohms, <u>+5%</u> , $\frac{1}{2}$ W	RC07GF473J
R2	RESISTOR: fxd, comp, 2.2 K ohms, <u>+5%</u> , $\frac{1}{2}$ W	RC07GF222J
R3 THRU R9	Same as R2	
R10	RESISTOR: fxd, comp, 3.9 K ohms, <u>+5%</u> , $\frac{1}{2}$ W	RC07GF392J
R11, R12	Same as R10	

REF SYMBOL	DESCRIPTION	TMC PART NUMBER
R13	RESISTOR: fxd, comp, 10 K ohms, <u>+5%</u> , $\frac{1}{2}$ W	RC07GF103J
R14	RESISTOR: fxd, comp, 4.7 K ohms, <u>+5%</u> , $\frac{1}{2}$ W	RC07GF472J
R15	Same as R13	
R16	Same as R14	
R17	Same as R13	
R18	Same as R14	
R19	Same as R10	
R20	RESISTOR: var, comp, 50 K ohms, <u>+30%</u>	RV124-2-503
R21	Same as R20	
R22	Same as R10	
R23	Same as R13	
R24	Same as R14	
R25	RESISTOR: var, comp, 100 ohms, <u>+5%</u> , 1 W	RC32GF101J
R26	RESISTOR: var, comp, 560 ohms, <u>+5%</u> , $\frac{1}{2}$ W	RC20GF561J

A12 HF OVEN OSCILLATOR ASSEMBLY

TMC PART NO. A10765-5

REF SYMBOL	DESCRIPTION	TMC PART NUMBER
A1	PRINTED CIRCUIT BOARD: HF oven control assembly	A10767-5
C11	CAPACITOR: fxd, mica, 18 pF, $\pm 5\%$, 100W VDC	CM111E180J1S
C12	CAPACITOR: var, cer, 15-60 pF, 100W VDC	CV112-9
C13	CAPACITOR: fxd, mica, 110 pF, $\pm 5\%$, 100W VDC	CM111E111J1S
C14	CAPACITOR: fxd, mica, 5 pF, $\pm 5\%$, 100W VDC	CM111C050J1S
C21, 31, 41, 51, 61, 71, 81	Same as C11	
C22, 32, 42, 52, 62, 72, 82	Same as C12	
C23, 33, 43, 53, 63, 73, 83	Same as C13	
C24, 34, 44, 54, 64, 74, 84	Same as C14	
C103	CAPACITOR: fxd, cer, 0.01 uF, +80% -20%, 25W VDC	CC100-41
C104	Same as C103	
C105	Not used	
C106	Same as C13	
C107, C108	Same as C103	
C109	CAPACITOR: fxd, mica, 33 pF, $\pm 5\%$, 500W VDC	CM111E330J5S
CR103	DIODE: Zener, 10.0V, 400mW, 5%	1N961B
Q11	TRANSISTOR	TX10003

REF SYMBOL	DESCRIPTION	TMC PART NUMBER
Q21, 31, 41, 51, 61, 71, 81	Same as Q11	
Q101, Q102	Same as Q11	
R11	RESISTOR: fxd, comp, 150 K ohms, <u>+5%</u> , $\frac{1}{2}$ W	RC07GF154J
R12	RESISTOR: fxd, comp, 18 K ohms, <u>+5%</u> , $\frac{1}{2}$ W	RC07GF183J
R13	RESISTOR: fxd, comp, 47 ohms, <u>+5%</u> , $\frac{1}{2}$ W	RC07GF470J
R21, 31, 41, 51, 61, 71, 81	Same as R11	
R22, 32, 42, 52, 62, 72, 82	Same as R12	
R23, 33, 43, 53, 63, 73, 83	Same as R13	
R102	RESISTOR: fxd, comp, 1 M ohms, <u>+5%</u> , $\frac{1}{2}$ W	RC07GF105J
R103	RESISTOR: fxd, comp, 1 K ohms, <u>+5%</u> , $\frac{1}{2}$ W	RC07GF102J
R104	RESISTOR: fxd, comp, 5.6 K ohms, <u>+5%</u> , $\frac{1}{2}$ W	RC07GF562J
R105	Same as R103	
R106	RESISTOR: fxd, comp, 560 ohms, <u>+5%</u> , $\frac{1}{2}$ W	RC07GF561J
R107	RESISTOR: fxd, comp, 3.3 K ohms, <u>+5%</u> , $\frac{1}{2}$ W	RC07GF332J
R108	Same as R103	
R109	RESISTOR: fxd, comp, 120 ohms, <u>+5%</u> , $\frac{1}{2}$ W	RC07GF121J

REF SYMBOL	DESCRIPTION	TMC PART NUMBER
R110	Same as R109	
R111	Same as R103	
Y11, 21, 31, 41, 51, 61, 71, 81	CRYSTAL: for desired frequency	CR27A/U

A12A1, HF OVEN CONTROL ASSEMBLY

TMC PART NO. A10767-5

REF SYMBOL	DESCRIPTION	TMC PART NUMBER
CR101	DIODE	1N4002
CR102	Same as CR101	
Q101	TRANSISTOR	2N2219A
Q102	Same as Q101	
Q103	TRANSISTOR	TX10002
R101	RESISTOR: fxd, comp, 620 ohms, +5%, 1/2W	RC07GF621J
R101A	RESISTOR: fxd, comp, value selected on test: 12 K ohms, +5%, 1/2W 2.2 K ohms, +5%, 1/2W 6.8 K ohms, +5%, 1/2W	RC07GF123J RC07GF222J RC07GF682J
R102	RESISTOR: fxd, comp, 2.2 K ohms, +5%, 1/2W	RC07GF222J
R103	RESISTOR: fxd, comp, 3.9 K ohms, +5%, 1/2W	RC07GF392J
R104	Same as R102	
R105	RESISTOR: fxd, comp, 1.8 K ohms, +5%, 1/2W	RC07GF182J
R106	Same as R102	
R107	RESISTOR: fxd, comp, 150 K ohms, +5%, 1/2W	RC07GF154J
RVT101	THERMISTOR	RR10005

A13, MIXER-DOUBLER ASSEMBLY

TMC PART NO A10900

REF SYMBOL	DESCRIPTION	TMC PART NUMBER
C1	CAPACITOR: fxd, cer, 0.02 uF, +80% -20%, 25W VDC	CC100-40
C2 THRU C8	Same as C1	
C9	CAPACITOR: fxd, cer, 0.01 uF, +80% -20%, 25W VDC	CC100-41
C10	Same as C9	
C11	CAPACITOR: fxd, cer, 560 pF, 300W VDC	CM111F561J3S
C12 THRU C25	Same as C9	
C26	CAPACITOR: fxd, cer, 0.2 pF, +80% -20%, 25W VDC	CC100-33
C27	CAPACITOR: var, cer, 15-60 pF	CV112-5
C28	CAPACITOR: fxd, cer, 220 pF, <u>+5%</u> , 500 W VDC	CM111E221J5S
C29	CAPACITOR: fxd, cer, 180 pF, <u>+5%</u> , 500W VDC	CM111E181J5S
C30	Same as C9	
CR1 THRU CR13	DIODE	1N914
CR14	DIODE: var, cap	MV1404
CR15	DIODE: Zener. 12V, 5%, 1W	1N3022B
CR16	DIODE	1N34A
CR17	Same as CR16	
L1	COIL: RF, fxd, 220 uH, <u>+10%</u>	CL275-221
L2 THRU L8	Same as L1	
L9	COIL: RF, fxd, 470 uH, <u>+10%</u>	CL275-471

REF SYMBOL	DESCRIPTION	TMC PART NUMBER
L10	COIL: RF, fxd, 0.68 uH, $\pm 20\%$	CL275-0R68
L11	COIL: RF, fxd, 33 uH, $\pm 10\%$	CL275-330
L12	COIL: RF, fxd, 10 uH, $\pm 10\%$	CL275-100
Q1	TRANSISTOR	2N2219A
Q2 THRU Q4	TRANSISTOR	2N3823
R1 THRU R8	RESISTOR: fxd, comp, 68 K ohms, $\pm 5\%$, $\frac{1}{2}W$	RC20GF683J
R9	RESISTOR: fxd, comp, 150 K ohms, $\pm 5\%$, $\frac{1}{2}W$	RC07GF154J
R10	RESISTOR: fxd, comp, 470 ohms, $\pm 5\%$, $\frac{1}{2}W$	RC07GF471J
R11	RESISTOR: fxd, comp, 1.2 K ohms, $\pm 5\%$, $\frac{1}{2}W$	RC07GF122J
R12	RESISTOR: fxd, comp, 15 K ohms, $\pm 5\%$, $\frac{1}{2}W$	RC07GF153J
R13	RESISTOR: var, comp, 10 K ohms, $\pm 5\%$	RV111U103A
R14	Same as R11	
R15	Same as R12	
R16	RESISTOR: fxd, comp, 18 K ohms, $\pm 5\%$, $\frac{1}{2}W$	RC07GF183J
R17	Same as R13	
R18	Same as R11	
R19	Same as R9	
R20	RESISTOR: fxd, comp, 680 K ohms, $\pm 5\%$, $\frac{1}{2}W$	RC20GF681J
R21	Same as R16	

REF SYMBOL	DESCRIPTION	TMC PART NUMBER
R22	RESISTOR: fxd, comp, 220 K ohms, <u>+5%</u> , $\frac{1}{4}W$	RC07GF224J
R23	RESISTOR: fxd, comp, 330 K ohms, <u>+5%</u> , $\frac{1}{4}W$	RC07GF334J
R24	RESISTOR: fxd, comp, 220 ohms, <u>+5%</u> , $\frac{1}{4}W$	RC07GF221J
R25	Same as R16	
R26	Same as R9	
R27	RESISTOR: fxd, comp, 270 ohms, <u>+5%</u> , $\frac{1}{4}W$	RC07GF271J
R28	RESISTOR: fxd, comp, 1 K ohms, <u>+5%</u> , $\frac{1}{4}W$	RC07GF102J
R29	RESISTOR: var, comp, 500 ohms, <u>+10%</u>	RV111U501A
R30	RESISTOR: fxd, comp, 820 ohms, <u>+5%</u> , $\frac{1}{4}W$	RC07GF821J
R31	RESISTOR: fxd, comp, 100 ohms, <u>+5%</u> , $\frac{1}{4}W$	RC07GF101J
T1	TRANSFORMER: RF	TF10070

A14, TRANSMIT RF ASSEMBLY

A10795-6 THRU A10795-18

REF SYMBOL	DESCRIPTION	TMC PART NUMBER
C1	CAPACITOR: fxd, cer, 0.02 uF, +80% -20%, 25 W VDC	CC100-40
C2	CAPACITOR: fxd, mica, $\pm 5\%$, 50 W VDC	
	A10795-6; 200 pF	CM111E201J5S
	A10795-7; 200 pF	CM111E201J5S
	A10795-8; 180 pF	CM111E181J5S
	A10795-9; 150 pF	CM111E151J5S
	A10795-10; "	"
	A10795-11; "	"
	A10795-12; "	"
	A10795-13; 91 pF	CM111E910J5S
	A10795-14; 82 pF	CM111E820J5S
	A10795-15; 68 pF	CM111E680J5S
	A10795-16; 56 pF	CM111E560J5S
	A10795-17; 51 pF	CM111E510J5S
	A10795-18; 47 pF	CM111E470J5S
C3	Same as C1	
C4	Same as C2	
C5 THRU C8	Same as C1	
C9	Same as C2	
C10 THRU C14	Same as C1	
C15	Same as C2	
CR1	DIODE	1N914
CR2	Same as CR1	
L1	COIL: fxd, RF, 33 uH, $\pm 10\%$	CL275-330
L2	COIL: fxd, RF, 120 uH, $\pm 10\%$	CL240-120
L3	COIL: FXD, RF, 33 uH, $\pm 10\%$	CL240-33

REF SYMBOL	DESCRIPTION	TMC PART NUMBER
Q1	TRANSISTOR	3N142
Q2	Same as Q1	
Q3	TRANSISTOR	2N4427
R1	RESISTOR: fxd, comp, 100 K ohms, $\pm 5\%$, $\frac{1}{2}W$	RC07GF104J
R4	RESISTOR: fxd, comp, 330 ohms, $\pm 5\%$, $\frac{1}{2}W$	RC07GF331J
R5	Same as R1	
R6	RESISTOR: fxd, comp, 680 ohms, $\pm 5\%$, $\frac{1}{2}W$	RC07GF681J
R7	Same as R4	
R8	RESISTOR: fxd, comp	S.O.T.
R9	RESISTOR: fxd, comp, 1.5 K ohms, $\pm 5\%$, $\frac{1}{2}W$	RC07GF152J
R10	RESISTOR: fxd, comp, 120 ohms, $\pm 5\%$, $\frac{1}{2}W$	RC07GF121J
R11	RESISTOR: fxd, comp, 30 ohms, $\pm 5\%$, $\frac{1}{2}W$	RC20GF300J
R12	RESISTOR: var, 1000 ohms, $\pm 10\%$	RV10005-4P
R13	RESISTOR: fxd, comp, 8.2 K ohms, $\pm 5\%$, $\frac{1}{2}W$	RC07GF822J
T1	TRANSFORMER: variable A10795-6 A10795-7 A10795-8 A10795-9 A10795-10 A10795-11 A10795-12	TF298-6 TT298-10 TT298-14 TT298-18 TT298-22 TT298-26 TT298-30

REF SYMBOL	DESCRIPTION	TMC PART NUMBER
T1	TRANSFORMER: variable A10795-13 A10795-14 A10795-15 A10795-16 A10795-17 A10795-18	TT298-34 TT298-38 TT298-42 TT298-46 TT298-50 TT298-54
T2	TRANSFORMER: variable A10795-6 A10795-7 A10795-8 A10795-9 A10795-10 A10795-11 A10795-12 A10795-13 A10795-14 A10795-15 A10795-16 A10795-17 A10795-18	TT298-5 TT298-9 TT298-13 TT298-17 TT298-21 TT298-25 TT298-29 TT298-33 TT298-37 TT298-41 TT298-45 TT298-49 TT298-53
T3	TRANSFORMER: variable A10795-6 A10795-7 A10795-8 A10795-9 A10795-10 A10795-11 A10795-12 A10795-13 A10795-14 A10795-15 A10795-16 A10795-17 A10795-18	TT298-7 TT298-11 TT298-15 TT298-19 TT298-23 TT298-27 TT298-31 TT298-35 TT298-39 TT298-43 TT298-47 TT298-51 TT298-55
T4	TRANSFORMER: variable A10795-6 A10795-7 A10795-8 A10795-9 A10795-10 A10798-11 A10795-12	TT298-8 TT298-12 TT298-16 TT298-20 TT298-24 TT298-28 TT298-32

REF SYMBOL	DESCRIPTION	TMC PART NUMBER
T4	TRANSFORMER: variable A10795-13 A10795-14 A10795-15 A10795-16 A10795-17 A10795-18	TT298-36 TT298-40 TT298-44 TT298-48 TT298-52 TT298-56

A15, WIDE BAND AMPLIFIER ASSEMBLY

TMC PART NO. A10934-5

REF SYMBOL	DESCRIPTION	TMC PART NUMBER
C1	CAPACITOR: fxd, elec. 1 uF, 25 W VDC	CE105-1-25
C2	CAPACITOR: fxd, cer, 0.01 uF, +80% -20%, 25 W VDC	CC100-41
C3, C4	Same as C2	
C5	Same as C1	
C6 THRU C13	Same as C2	
CR1	DIODE	IN4002
CR2	Same as CR1	
L1	COIL, RF: fxd, 150 uH, $\pm 10\%$	CL275-151
L2	COIL, RF: fxd, 15 uH, $\pm 10\%$	CL275-150
L3	COIL, RF: fxd, 33 uH, $\pm 10\%$	CL240-33
L4	COIL, RF: fxd, 220 uH, $\pm 10\%$	CL275-221
Q1	TRANSISTOR	2N3866
Q2	TRANSISTOR	2N3375
R1	RESISTOR: fxd, comp, 1 K ohms, $\pm 5\%$, $\frac{1}{4}W$	RC07GF102J
R2	RESISTOR: fxd, comp, 150 ohms, $\pm 5\%$, $\frac{1}{4}W$	RC07GF151J
R3	RESISTOR: fxd, comp, 1.2 K ohms, $\pm 5\%$, $\frac{1}{4}W$	RC07GF122J
R4	RESISTOR: var, comp, 5 K ohms, $\pm 20\%$	RV111U502B
R5	RESISTOR: fxd, comp, 2.2 K ohms, $\pm 5\%$, $\frac{1}{4}W$	RC07GF222J

REF SYMBOL	DESCRIPTION	TMC PART NUMBER
R6	RESISTOR: fxd, comp, 220 ohms, <u>+5%</u> , 2W	RC42GF221J
R7	RESISTOR: fxd, comp, 33 ohms, <u>+5%</u> , ½W	RC20GF330J
R8	RESISTOR: fxd, comp, 1.5 K ohms, <u>+5%</u> , ½W	RC07GF152J
R9	RESISTOR: fxd, comp, 15 ohms, <u>+5%</u> , 1W	RC32GF150J
R10	Same as R7	
R11	RESISTOR: fxd, comp, 100 ohms, <u>+5%</u> , 1W	RC32GF101J
R12	RESISTOR: fxd, comp, 820 ohms	RC20GF821J
R13	RESISTOR: fxd, comp, 1.8 K ohms, <u>+5%</u> , ½W	RC07GF182J
R14	RESISTOR: fxd, comp, 3.3 K ohms, <u>+5%</u> , ½W	RC07GF332J
T1	TRANSFORMER: RF	TF10069
T2	Same as T1	

A17 FILTER ASSEMBLY

A10975-5

REF SYMBOL	DESCRIPTION	TMC PART NUMBER
C1	CAPACITOR: fxd, cer, 0.001 uf GMV, 500 WVDC	CC100-29
C2 THRU C8	Same as C1	
L1	COIL: RF, 150 uH, <u>+10%</u>	CL275-151
L2 THRU L4	Same as L1	

A18 FILTER ASSEMBLY,

A10976-5

REF SYMBOL	DESCRIPTION	TMC PART NUMBER
C1	CAPACITOR: fxd, cer, 0.001 uf GMV, 500 WVDC	CC100-29
C2 THRU C14	Same as C1	
L1	COIL: RF, 150 uH, <u>+ 10%</u>	CL275-151
L2 THRU L7	Same as L1	

A19 FILTER ASSEMBLY

A10977-5

REF SYMBOL	DESCRIPTION	TMC PART NUMBER
C1	CAPACITOR: fxd, cer, 0.001 uf GMV, 500 WVDC	CC100-29
C2 THRU C6	Same as C1	
L1	COIL: RF, 150 uH, <u>+10%</u>	CL275-151
L2 THRU L3	Same as L1	

A20, AF AMPLIFIER/OSCILLATOR

TMC PART NO. - A11020-5

REF SYMBOL	DESCRIPTION	TMC PART NUMBER
A1	INTEGRATED CIRCUIT	MC1741CP
A2	INTEGRATED CIRCUIT	MC1590G
A3	INTEGRATED CIRCUIT	NW10011
A4	Same as A1	
C1	CAPACITOR: solid, tant, 1uF	CE10014-1.0-35
C2, C3	CAPACITOR: fxd, cer, 0.01 uF	CC100-43
C4	CAPACITOR: solid, tant, 10 uF	CE10014-10-35
C5	CAPACITOR: fxd, cer, 0.47 uF	CC10026-17
C9	CAPACITOR: solid, tant, 0.47 uF	CE10014-0.47-35
C10, C11	Same as C2	
C12	Same as C5	
C13, C14	Same as C9	
C15	CAPACITOR: fxd, cer, 2.2 uF	CE10014-2.2-25
C16, C17, C18	CAPACITOR: solid, tant, 47 uF	CE10014-47-63
C19	Same as C2	
C20	Same as C9	
C21	Same as C1	
C22	Same as C2	
C23	CAPACITOR: elect, min, 100 uF	CE10017-100-35-B
C24, C25	Same as C4	
C26	Same as C1	
C27	CAPACITOR: fxd, cer, 0.1 uF	CC100-28
C28 THRU C31	Same as C16	

REF SYMBOL	DESCRIPTION	TMC PART NUMBER
CR1	DIODE	1N5341A
CR2	DIODE	1N914B
CR3	Same as CR1	
CR4, CR5	Same as CR2	
L1	COIL, RF: fxd 47 mH \pm 100%	CL10058
Q1	TRANSISTOR	2N3904
Q2	TRANSISTOR	2N5459
Q3	TRANSISTOR	2N5361
R1	RESISTOR: fxd, comp, 1.8K ohms \pm 5%, 1/4 W	RC07GF182J
R2	RESISTOR: fxd, comp, 470 ohms, \pm 5%, 1/2 W	RC20GF471J
R3	RESISTOR: fxd, comp, 82K ohms, \pm 5%, 1/4 W	RC07GF823J
R4	RESISTOR: fxd, comp, 120K ohms \pm 5%, 1/4 W	RC07GF124J
R5	RESISTOR: fxd, comp, 1K ohms, \pm 5%, 1/4 W	RC07GF102J
R6, R7	RESISTOR: var, comp, 500 ohms \pm 10%	RV111A501A
R8	Same as R5	
R10	Same as R2	
R11	RESISTOR: fxd, comp, 22K ohms \pm 5%, 1/4 W	RC07GF223J
R12	Same as R5	
R13	RESISTOR: fxd, comp, 470 ohms \pm 5%, 1/4 W	RC07GF471J
R14	RESISTOR: var, W/W, 50K ohms	RV124-2-503
R15	Same as R5	

REF SYMBOL	DESCRIPTION	TMC PART NUMBER
R16	RESISTOR: fxd, comp 270 ohms \pm 5%, 1/4 W	RC07GF271J
R17	Same as R5	
R18	RESISTOR: fxd, comp 10K ohms \pm 5%, 1/4 W	RC07GF103J
R19, R20	RESISTOR: var, W/W, 1K ohms	RV124-2-102
R21	RESISTOR: fxd, comp 220 ohms \pm 5%, 1/2 W	RC20GF221J
R22	RESISTOR: fxd, comp, 3.3K ohms \pm 5%, 1/4 W	RC07GF332J
R23	Same as R1	
R24	Same as R13	
R25	Same as R1	
R26	RESISTOR: fxd, comp, 4.7K ohms \pm 5%, 1/4 W	RC07GF472J
R30, R31	Same as R26	
R32	RESISTOR: fxd, comp, 2.2 K ohms \pm 5%, 1/4 W	RC07GF222J
R33	RESISTOR: var, w/w 20 K ohms	RV124-2-203
R34	RESISTOR: fxd, comp, 330 ohms \pm 5%, 1/4 W	RC07GF331J
R35, R36	RESISTOR: fxd, comp, 330 ohms \pm 5%, 1/2 W	RC20GF331J
R37	RESISTOR: var, comp, 1K ohms \pm 10%	RV111U102B
R38	Same as R18	
T1 THRU T4	TRANSFORMER	TF10081-4

SECTION 7
SCHEMATIC DIAGRAMS

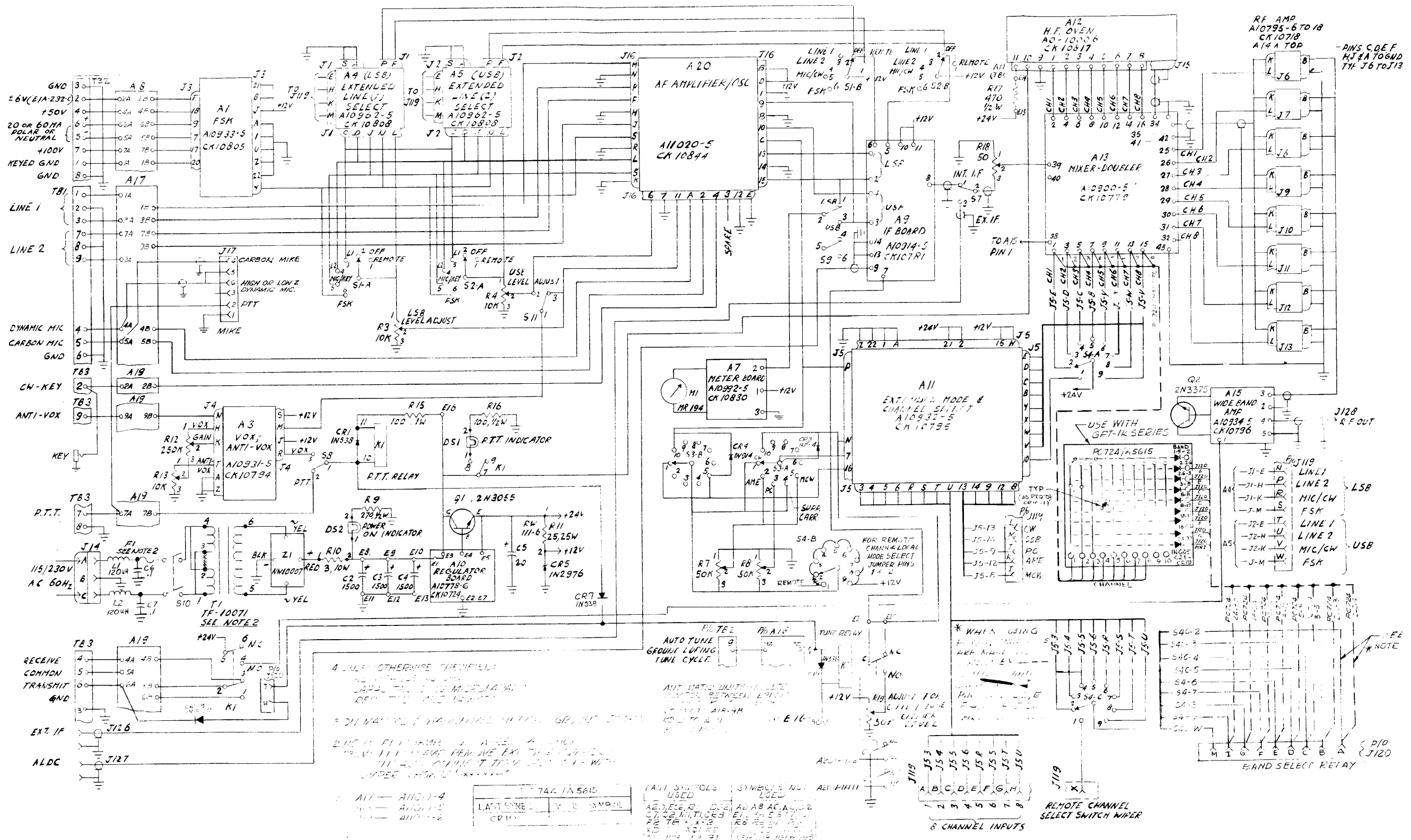

4. UNLESS OTHERWISE SPECIFIED:
 ALL CAPS TO BE MICROJANET
 RESISTOR VALUES IN OHMS

5. DIMENSIONS IN PARENTHESES ARE FOR CONVENIENCE ONLY

6. UNLESS OTHERWISE SPECIFIED, ALL DIMENSIONS ARE IN INCHES

7. ALL DIMENSIONS ARE TO CENTER UNLESS OTHERWISE SPECIFIED

8. UNLESS OTHERWISE SPECIFIED, ALL DIMENSIONS ARE TO CENTER UNLESS OTHERWISE SPECIFIED

742	1A5615
LAST SYMBOL	VALUE AND UNIT
CR10	100K 1/2W

(A) SYMBOLS USED

AE, EC, R, L, C, S, M, P, Q, T, V, W, X, Y, Z, AA, AB, AC, AD, AE, AF, AG, AH, AI, AJ, AK, AL, AM, AN, AO, AP, AQ, AR, AS, AT, AU, AV, AW, AX, AY, AZ, BA, BB, BC, BD, BE, BF, BG, BH, BI, BJ, BK, BL, BM, BN, BO, BP, BQ, BR, BS, BT, BU, BV, BW, BX, BY, BZ, CA, CB, CC, CD, CE, CF, CG, CH, CI, CJ, CK, CL, CM, CN, CO, CP, CQ, CR, CS, CT, CU, CV, CW, CX, CY, CZ, DA, DB, DC, DD, DE, DF, DG, DH, DI, DJ, DK, DL, DM, DN, DO, DP, DQ, DR, DS, DT, DU, DV, DW, DX, DY, DZ, EA, EB, EC, ED, EE, EF, EG, EH, EI, EJ, EK, EL, EM, EN, EO, EP, EQ, ER, ES, ET, EU, EV, EW, EX, EY, EZ, FA, FB, FC, FD, FE, FF, FG, FH, FI, FJ, FK, FL, FM, FN, FO, FP, FQ, FR, FS, FT, FU, FV, FW, FX, FY, FZ, GA, GB, GC, GD, GE, GF, GG, GH, GI, GJ, GK, GL, GM, GN, GO, GP, GQ, GR, GS, GT, GU, GV, GW, GX, GY, GZ, HA, HB, HC, HD, HE, HF, HG, HH, HI, HJ, HK, HL, HM, HN, HO, HP, HQ, HR, HS, HT, HU, HV, HW, HX, HY, HZ, IA, IB, IC, ID, IE, IF, IG, IH, II, IJ, IK, IL, IM, IN, IO, IP, IQ, IR, IS, IT, IU, IV, IW, IX, IY, IZ, JA, JB, JC, JD, JE, JF, JG, JH, JI, JJ, JK, JL, JM, JN, JO, JP, JQ, JR, JS, JT, JU, JV, JW, JX, JY, JZ, KA, KB, KC, KD, KE, KF, KG, KH, KI, KJ, KK, KL, KM, KN, KO, KP, KQ, KR, KS, KT, KU, KV, KW, KX, KY, KZ, LA, LB, LC, LD, LE, LF, LG, LH, LI, LJ, LK, LL, LM, LN, LO, LP, LQ, LR, LS, LT, LU, LV, LW, LX, LY, LZ, MA, MB, MC, MD, ME, MF, MG, MH, MI, MJ, MK, ML, MM, MN, MO, MP, MQ, MR, MS, MT, MU, MV, MW, MX, MY, MZ, NA, NB, NC, ND, NE, NF, NG, NH, NI, NJ, NK, NL, NM, NN, NO, NP, NQ, NR, NS, NT, NU, NV, NW, NX, NY, NZ, OA, OB, OC, OD, OE, OF, OG, OH, OI, OJ, OK, OL, OM, ON, OO, OP, OQ, OR, OS, OT, OU, OV, OW, OX, OY, OZ, PA, PB, PC, PD, PE, PF, PG, PH, PI, PJ, PK, PL, PM, PN, PO, PP, PQ, PR, PS, PT, PU, PV, PW, PX, PY, PZ, QA, QB, QC, QD, QE, QF, QG, QH, QI, QJ, QK, QL, QM, QN, QO, QP, QQ, QR, QS, QT, QU, QV, QW, QX, QY, QZ, RA, RB, RC, RD, RE, RF, RG, RH, RI, RJ, RK, RL, RM, RN, RO, RP, RQ, RR, RS, RT, RU, RV, RW, RX, RY, RZ, SA, SB, SC, SD, SE, SF, SG, SH, SI, SJ, SK, SL, SM, SN, SO, SP, SQ, SR, SS, ST, SU, SV, SW, SX, SY, SZ, TA, TB, TC, TD, TE, TF, TG, TH, TI, TJ, TK, TL, TM, TN, TO, TP, TQ, TR, TS, TT, TU, TV, TW, TX, TY, TZ, UA, UB, UC, UD, UE, UF, UG, UH, UI, UJ, UK, UL, UM, UN, UO, UP, UQ, UR, US, UT, UY, UZ, VA, VB, VC, VD, VE, VF, VG, VH, VI, VJ, VK, VL, VM, VN, VO, VP, VQ, VR, VS, VT, VU, VV, VW, VX, VY, VZ, WA, WB, WC, WD, WE, WF, WG, WH, WI, WJ, WK, WL, WM, WN, WO, WP, WQ, WR, WS, WT, WU, WV, WW, WX, WY, WZ, XA, XB, XC, XD, XE, XF, XG, XH, XI, XJ, XK, XL, XM, XN, XO, XP, XQ, XR, XS, XT, XU, XV, XW, XX, XY, XZ, YA, YB, YC, YD, YE, YF, YG, YH, YI, YJ, YK, YL, YM, YN, YO, YP, YQ, YR, YS, YT, YU, YV, YW, YX, YY, YZ, ZA, ZB, ZC, ZD, ZE, ZF, ZG, ZH, ZI, ZJ, ZK, ZL, ZM, ZN, ZO, ZP, ZQ, ZR, ZS, ZT, ZU, ZV, ZW, ZX, ZY, ZZ

SME-5
 MAIN SCHEMATIC
 FIG.7-1

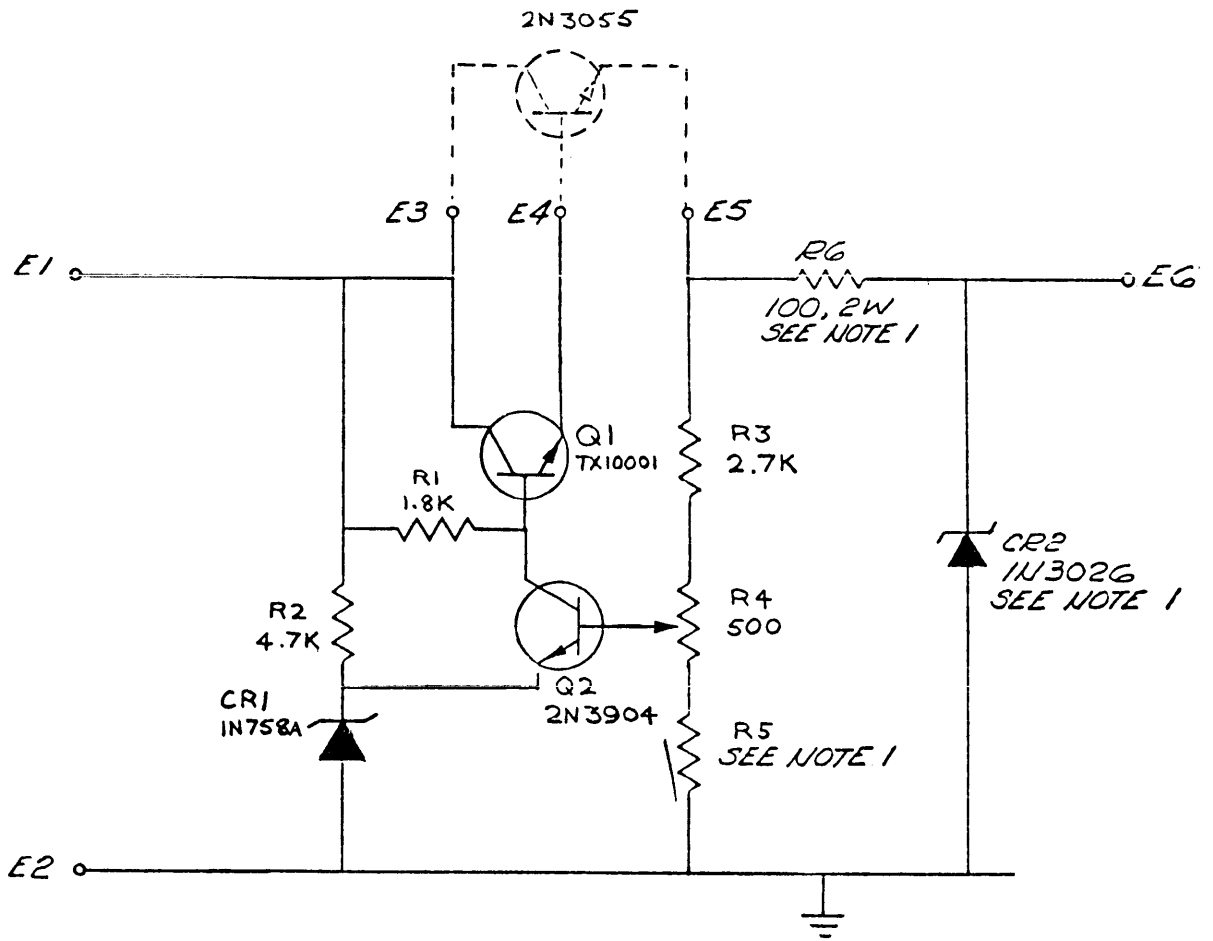

2. ALL RESISTANCE TO BE IN OHMS
 1 R6 & CR2 TO BE USED FOR A10778-5 ONLY.
 VALUE OF R5 TO BE: 1.5K FOR A10778-5
 2.2K FOR A10778-6

NOTES

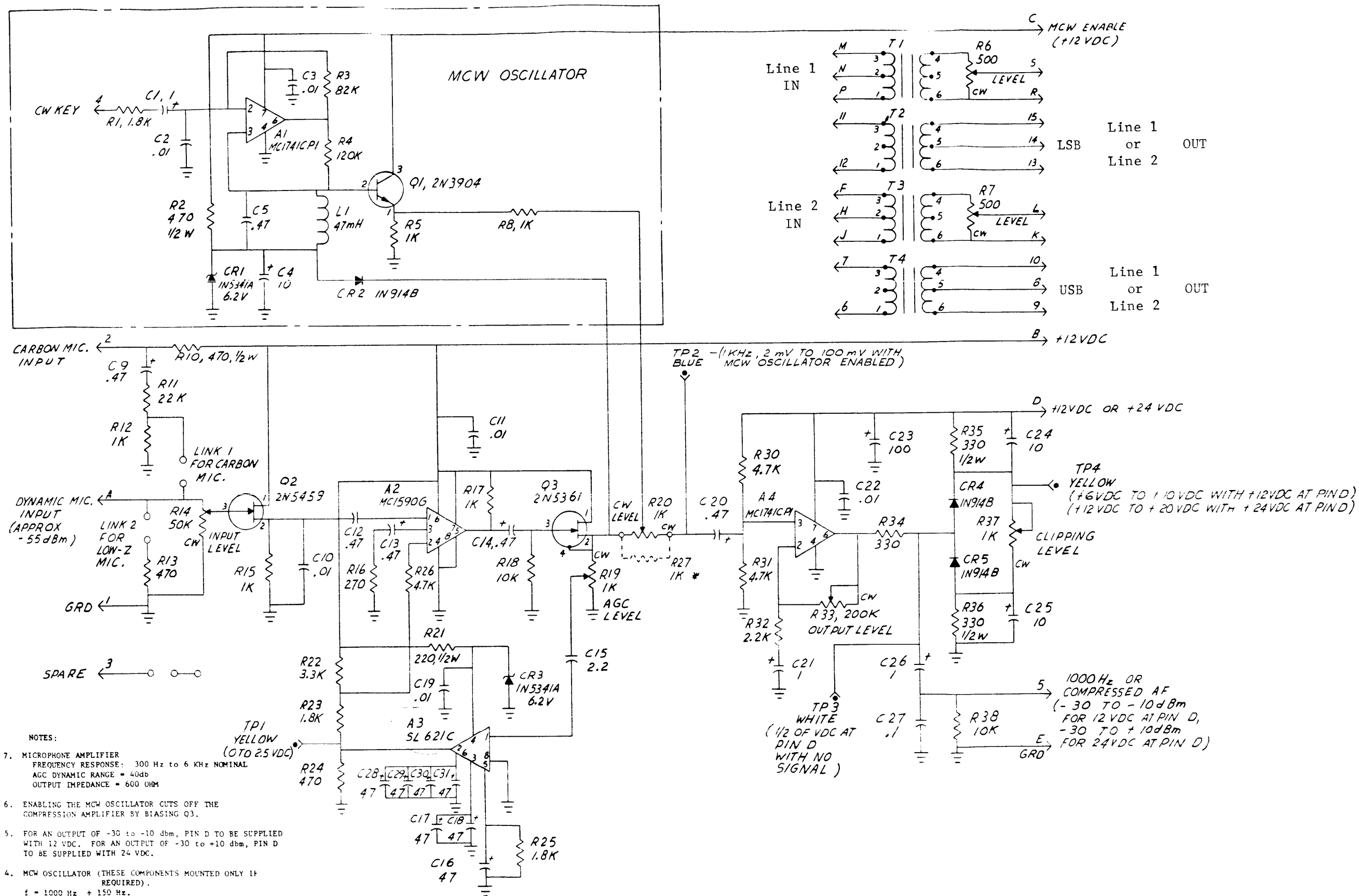

- NOTES:
- MICROPHONE AMPLIFIER
FREQUENCY RESPONSE: 300 Hz to 6 kHz NOMINAL
AGC DYNAMIC RANGE = 40db
OUTPUT IMPEDANCE = 600 OHM
 - ENABLING THE MCW OSCILLATOR CUTS OFF THE COMPRESSION AMPLIFIER BY BIASING Q3.
 - FOR AN OUTPUT OF -30 TO -10 dbm, PIN D TO BE SUPPLIED WITH 12 VDC. FOR AN OUTPUT OF -30 TO +10 dbm, PIN D TO BE SUPPLIED WITH 24 VDC.
 - MCW OSCILLATOR (THESE COMPONENTS MOUNTED ONLY IF REQUIRED).
 $f = 1000 \text{ Hz} \pm 150 \text{ Hz}$.
 - WHEN THE MCW OSCILLATOR IS NOT MOUNTED ON THE BOARD REPLACE R20 WITH R27.
 - TRANSFORMERS: (ONLY THOSE TRANSFORMERS REQUIRED ARE MOUNTED).

T1, T3: 600 OHM BALANCE TO UNBALANCE
T2, T4: 600 OHM BALANCE

PERFORMANCE DATA

- CAPACITANCE IN MICROFARDS.
RESISTANCE IN OHMS, $\frac{1}{2}$ W.
UNLESS OTHERWISE SPECIFIED.

221173

A20
AF AMPLIFIER/OSCILLATOR
FIG. 7-3

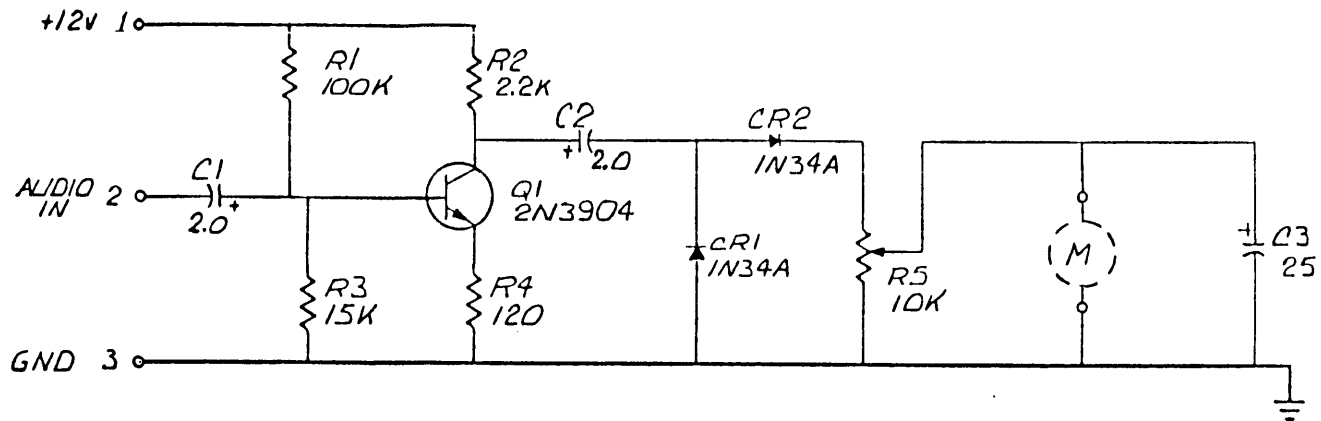

NOTE: UNLESS OTHERWISE SPECIFIED
 RESISTANCE IN Ω , 1/4W
 CAPACITANCE IN μF

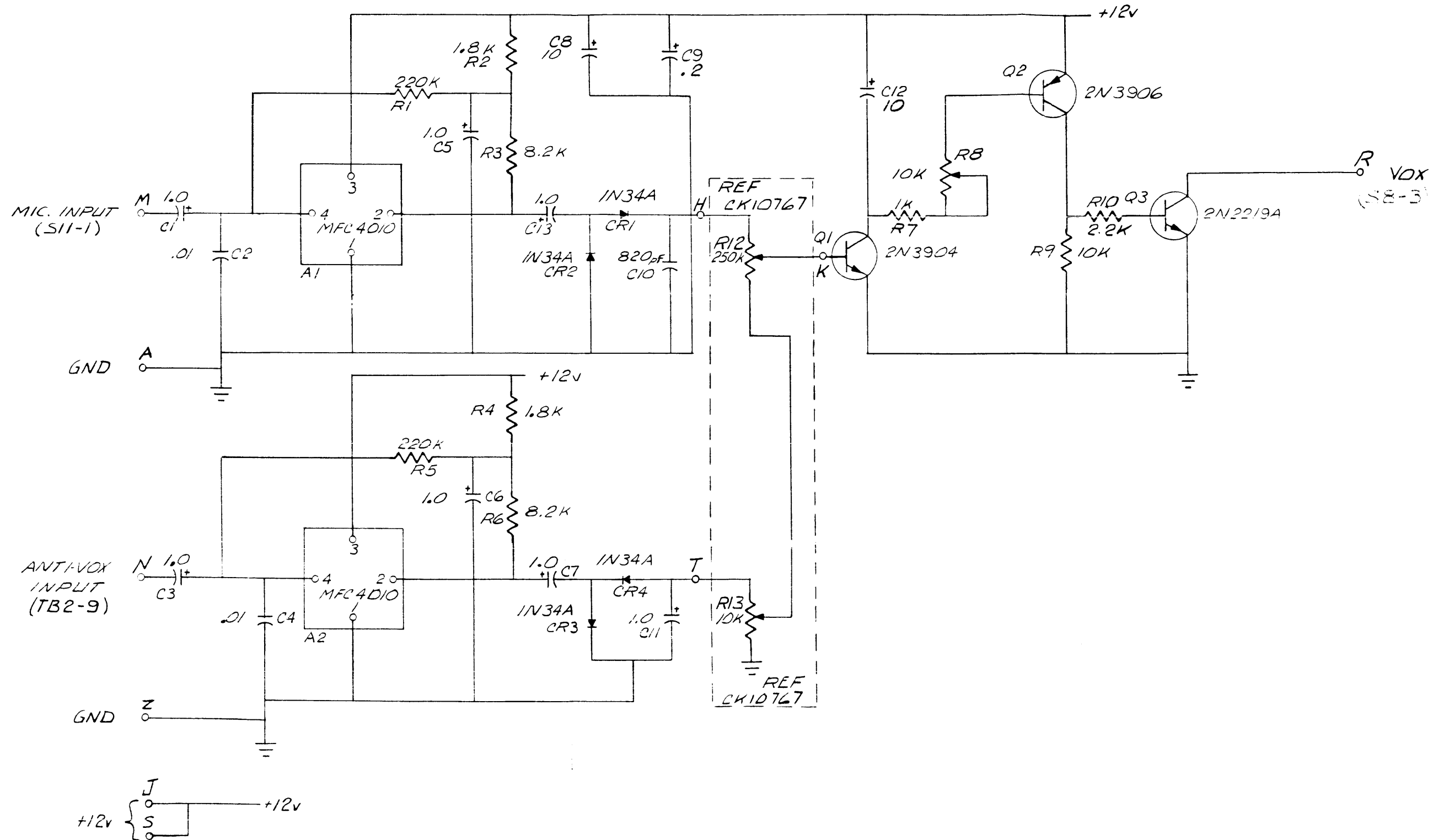

UNLESS OTHERWISE SPECIFIED: ALL CAPACITANCE IN μ F.
ALL RESISTANCE IN Ω , $\frac{1}{4}$ W.

NOTES:~

1. FL1801 IS FX 10014 - 1D
2. FL1802 IS FX 10014 - 2D
3. LOWER SIDEBAND FILTER REMOVED FOR "USB ONLY" APPLICATION
4. UPPER SIDEBAND FILTER REMOVED FOR "LSB ONLY" APPLICATION.

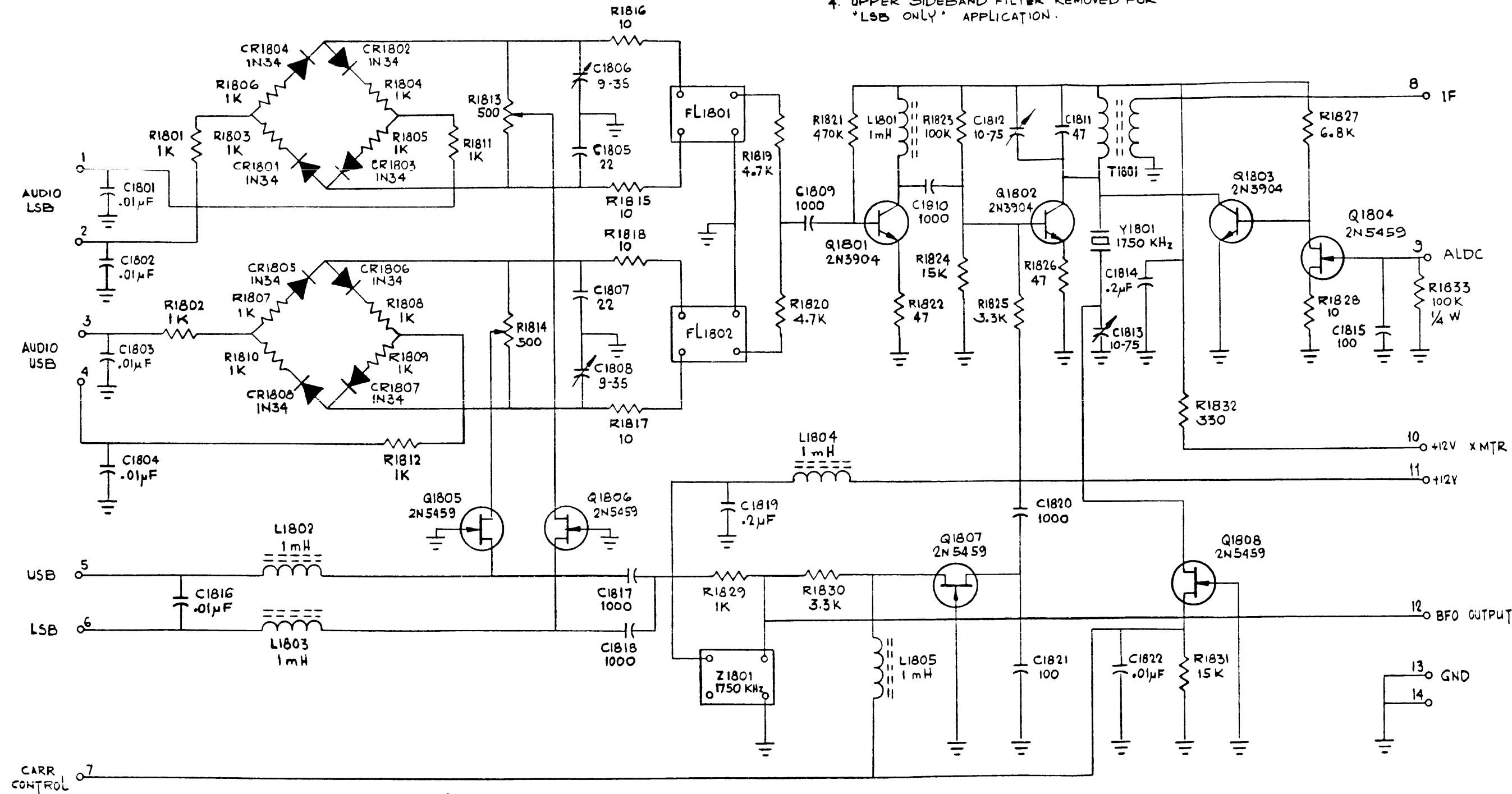

UNLESS OTHERWISE SPECIFIED :
 CAPACITANCE IN PICO FARAD
 RESISTANCE IN OHMS , 1/2 WATT

A9
 IF BOARD
 FIG. 7-6

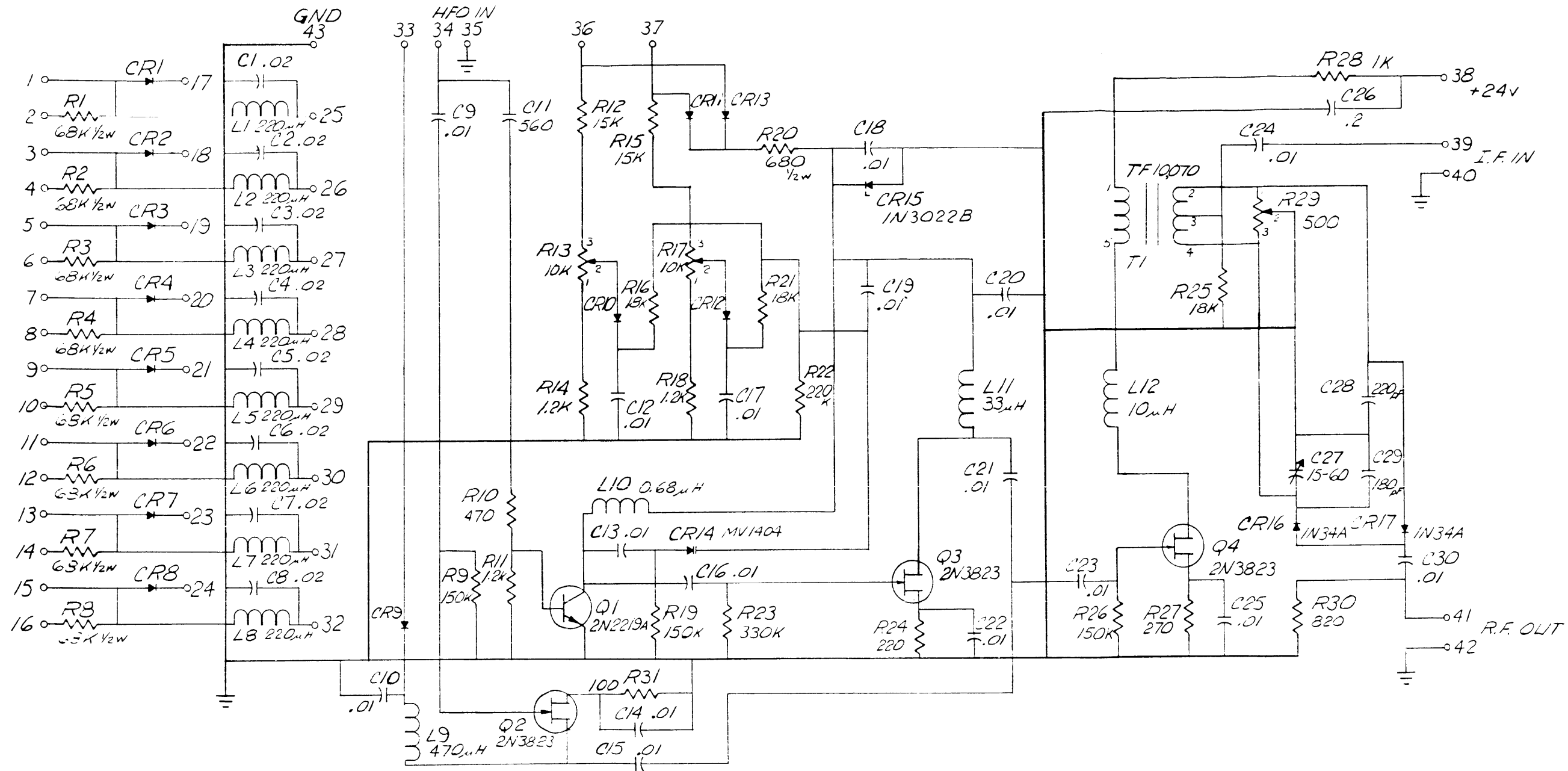

NOTE: UNLESS OTHERWISE SPECIFIED;
 RESISTANCE IN Ω 15%, 1/4W;
 CAPACITANCE IN μ F;
 DIODES 1N914.

A13
 MIXER-DOUBLER
 FIG. 7-7

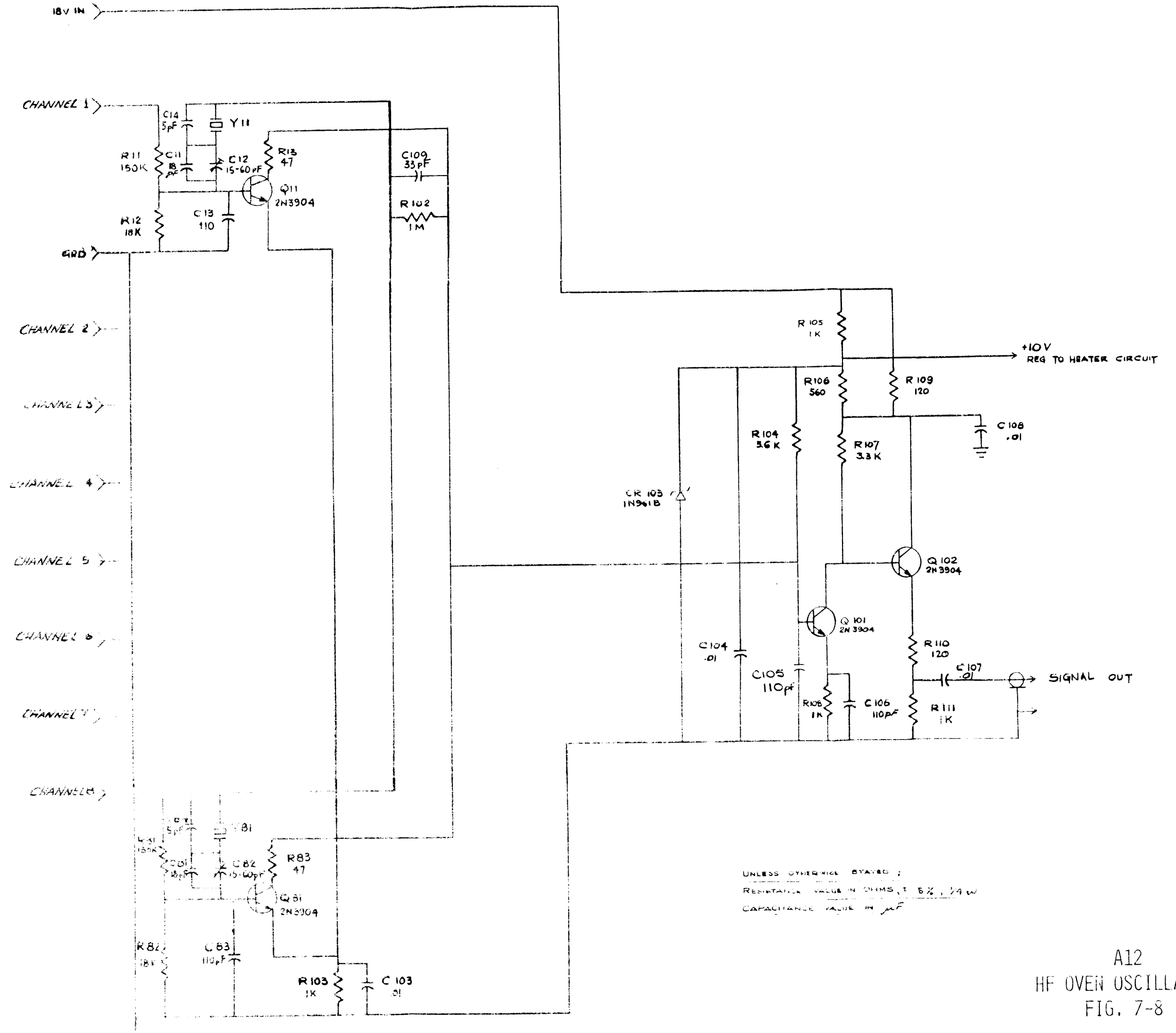

UNLESS OTHERWISE STATED:
 RESISTANCE VALUE IN OHMS, ± 5%, 1/4 W
 CAPACITANCE VALUE IN μF

A12
 HF OVEN OSCILLATOR
 FIG. 7-8

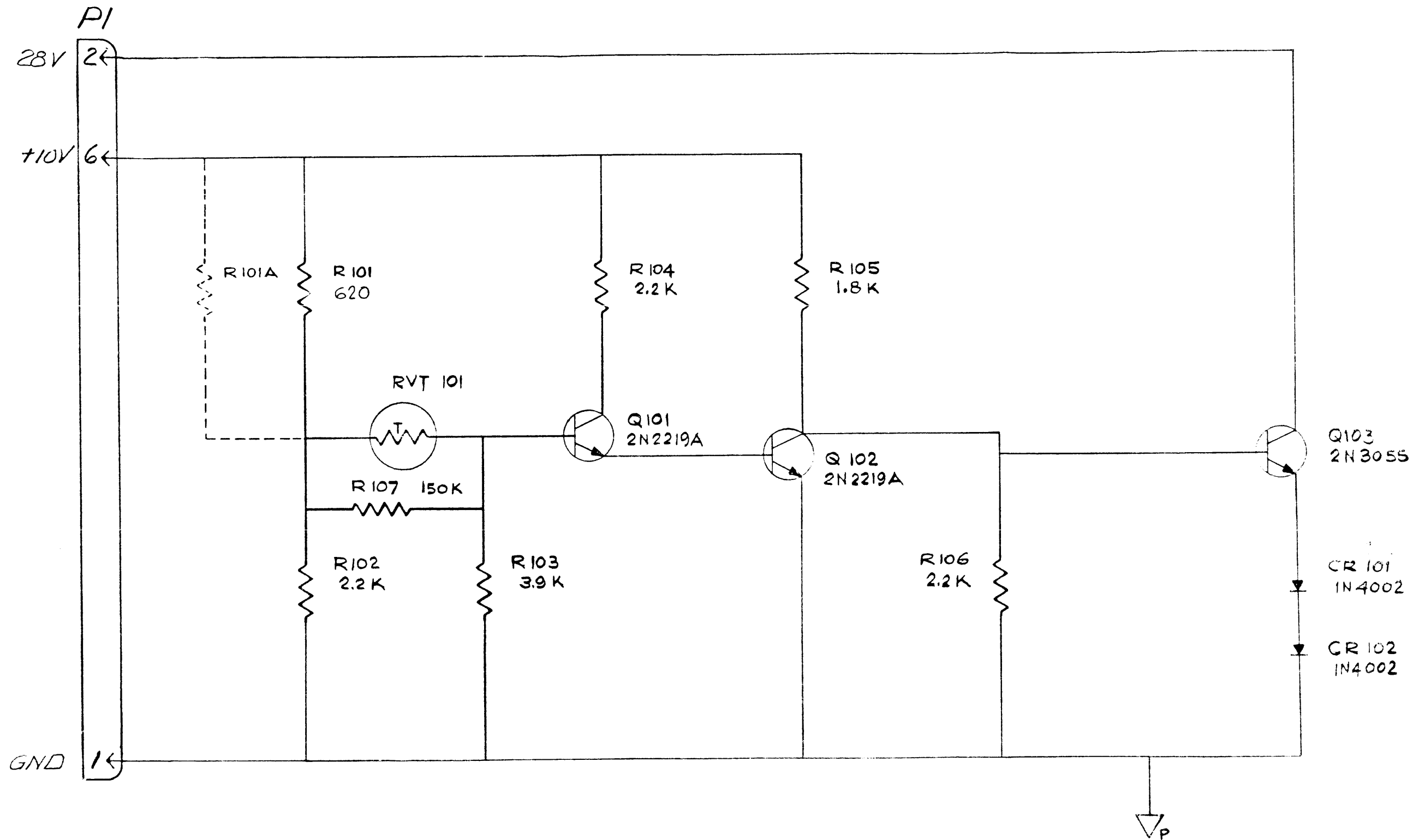

UNLESS OTHERWISE STATED :

RESISTANCE VALUE IN OHMS $\pm 5\%$.25 WATT
 CAPACITANCE VALUE IN PICO FARADS - WHOLE NUMBERS.
 MICRO FARADS - DECIMAL NUMBERS.

∇_P DENOTES POWER GROUND, SUPPLIED ONLY THROUGH J1.

A12/A1
 OVEN CONTROL BOARD
 FIG. 7-5

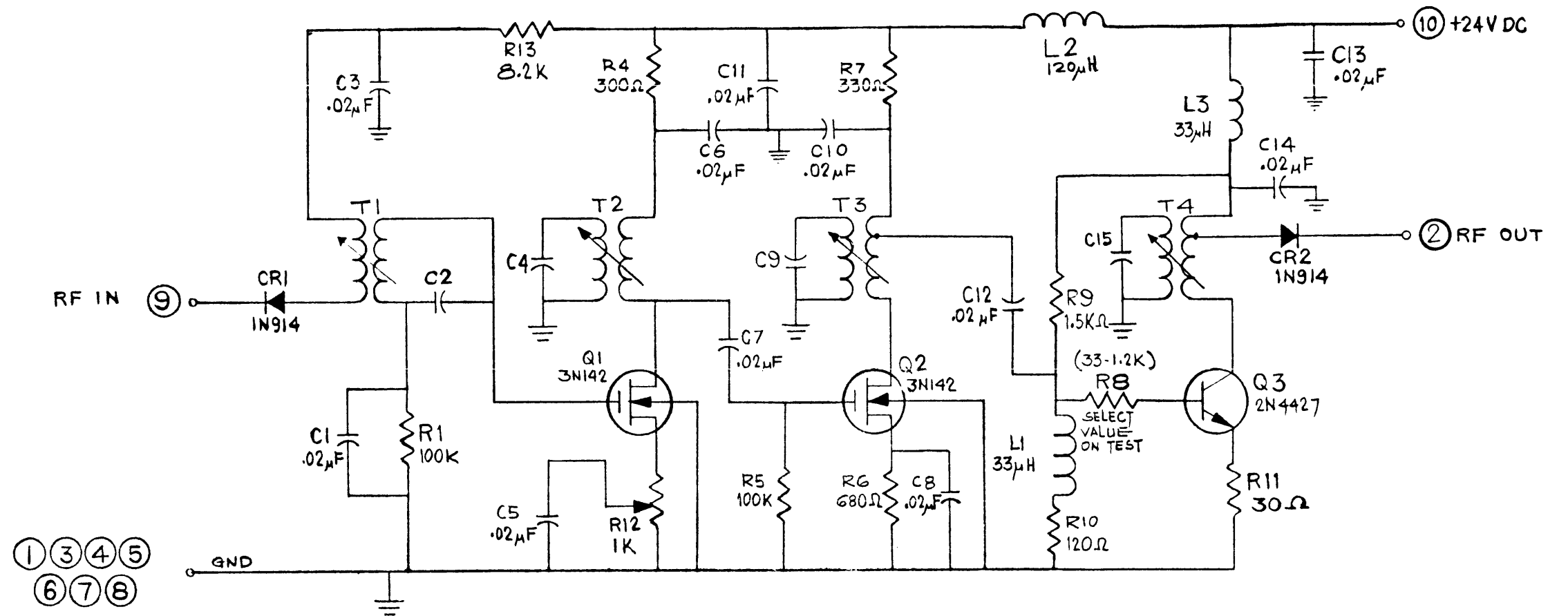

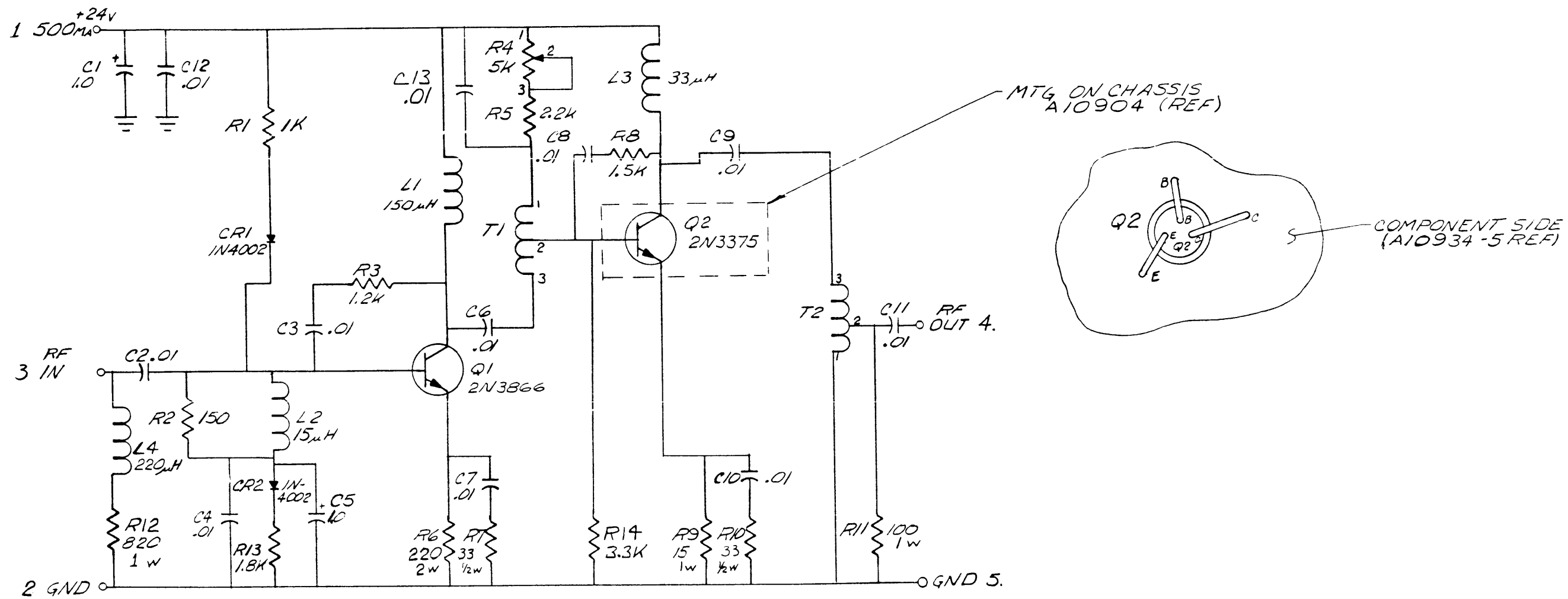

NOTE: UNLESS OTHERWISE SPECIFIED;
 RESISTANCE IN Ω , $\frac{1}{4}$ W;
 CAPACITANCE IN μ F.

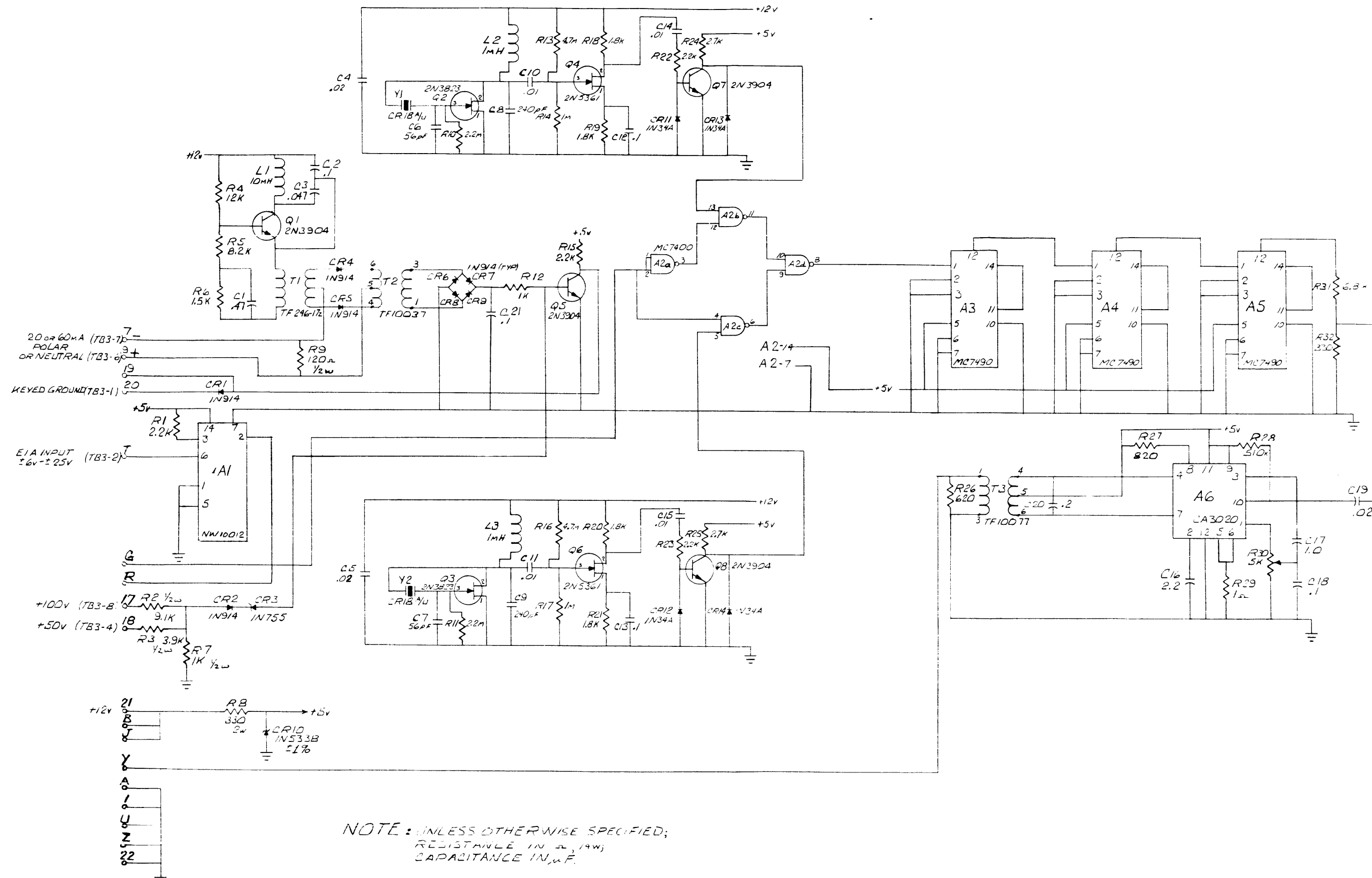

NOTE: UNLESS OTHERWISE SPECIFIED;
 RESISTANCE IN Ω , μ W;
 CAPACITANCE IN μ F.

A1
 FREQUENCY SHIFT
 FIG. 7-12

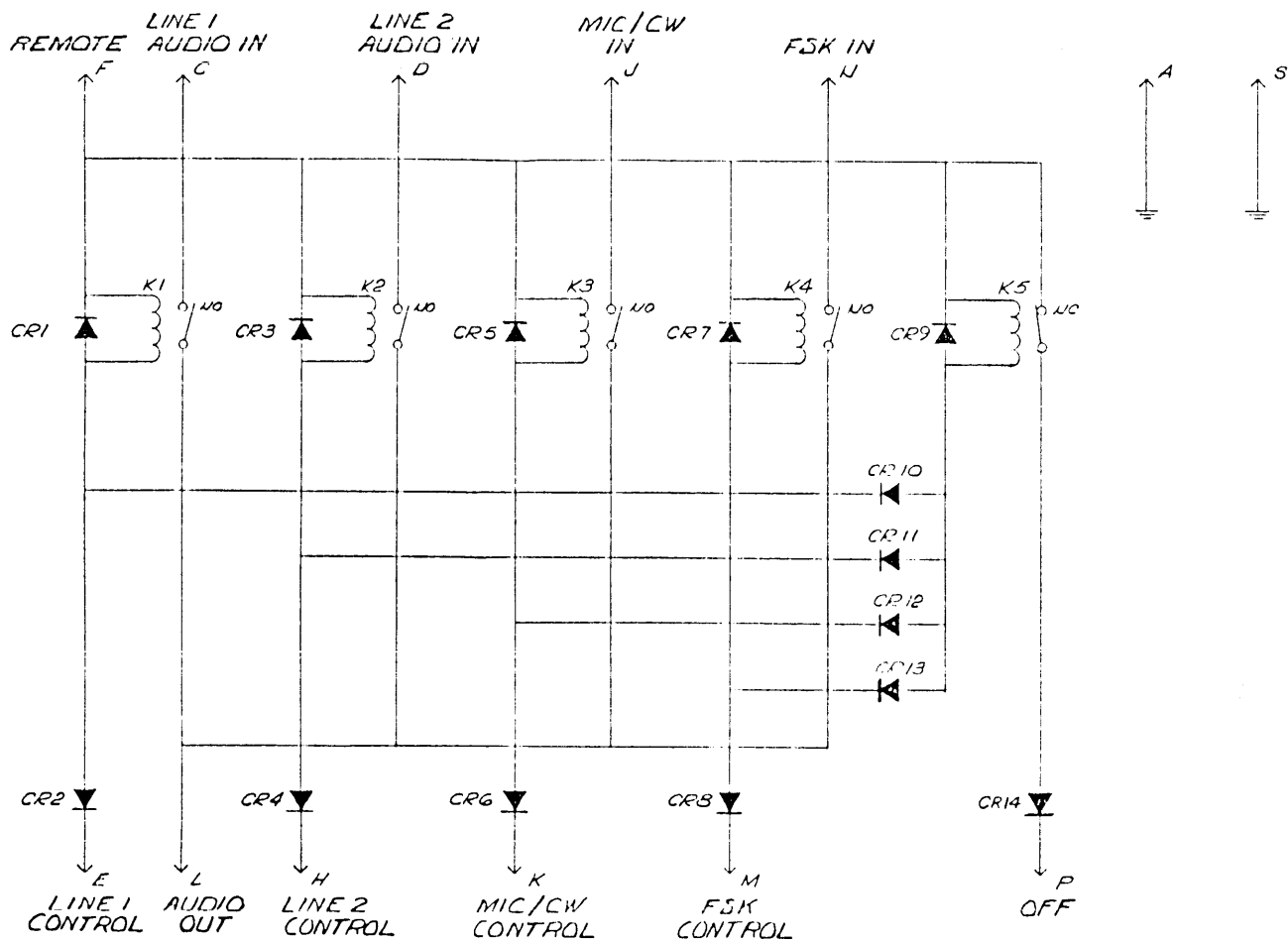

ALL DIODES TYPE 1N914B

A4/A5
EXTENDED LINE SELECT
FIG. 7-13

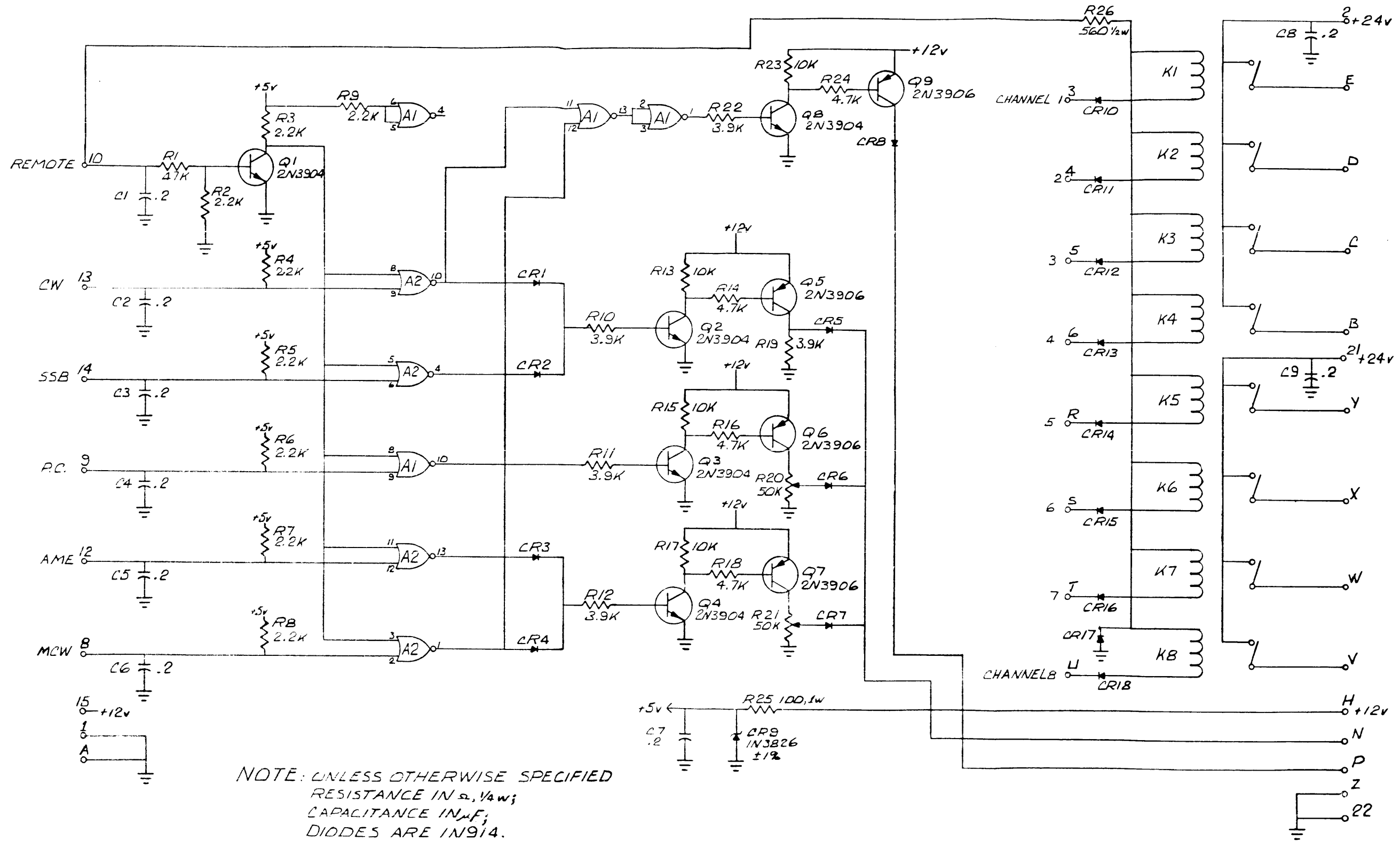

ALL
 EXTENDED MODE AND
 CHANNEL SELECT
 FIG. 7-14