

★

TECHNICAL MANUAL

for

SIDEBAND

MULTI-CHANNEL EXCITER

MODEL SME ()-6



THE TECHNICAL MATERIEL CORPORATION
MAMARONECK, N. Y. OTTAWA, CANADA

★

★

TECHNICAL MANUAL

for

SIDEBAND

MULTI-CHANNEL EXCITER

MODEL SME ()-6



THE TECHNICAL MATERIEL CORPORATION
MAMARONECK, N. Y. **OTTAWA, CANADA**

COPYRIGHT 1969
THE TECHNICAL MATERIEL CORPORATION

NOTICE

THE CONTENTS AND INFORMATION CONTAINED IN THIS INSTRUCTION MANUAL IS PROPRIETARY TO THE TECHNICAL MATERIEL CORPORATION TO BE USED AS A GUIDE TO THE OPERATION AND MAINTENANCE OF THE EQUIPMENT FOR WHICH THE MANUAL IS ISSUED AND MAY NOT BE DUPLICATED EITHER IN WHOLE OR IN PART BY ANY MEANS WHATSOEVER WITHOUT THE WRITTEN CONSENT OF THE TECHNICAL MATERIEL CORPORATION.

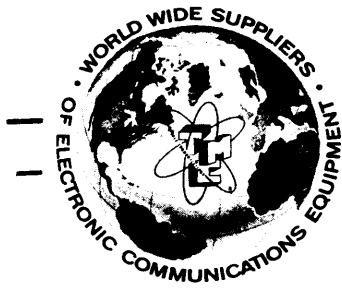

THE TECHNICAL MATERIEL CORPORATION

C O M M U N I C A T I O N S E N G I N E E R S

700 FENIMORE ROAD

MAMARONECK, N. Y.

W a r r a n t y

The Technical Materiel Corporation, hereinafter referred to as TMC, warrants the equipment (except electron tubes,* fuses, lamps, batteries and articles made of glass or other fragile or other expendable materials) purchased hereunder to be free from defect in materials and workmanship under normal use and service, when used for the purposes for which the same is designed, for a period of one year from the date of delivery F.O.B. factory. TMC further warrants that the equipment will perform in a manner equal to or better than published technical specifications as amended by any additions or corrections thereto accompanying the formal equipment offer.

TMC will replace or repair any such defective items, F.O.B. factory, which may fail within the stated warranty period, PROVIDED:

1. That any claim of defect under this warranty is made within sixty (60) days after discovery thereof and that inspection by TMC, if required, indicates the validity of such claim to TMC's satisfaction.
2. That the defect is not the result of damage incurred in shipment from or to the factory.
3. That the equipment has not been altered in any way either as to design or use whether by replacement parts not supplied or approved by TMC, or otherwise.
4. That any equipment or accessories furnished but not manufactured by TMC, or not of TMC design shall be subject only to such adjustments as TMC may obtain from the supplier thereof.

Electron tubes*furnished by TMC, but manufactured by others, bear only the warranty given by such other manufacturers. Electron tube warranty claims should be made directly to the manufacturer of such tubes.

TMC's obligation under this warranty is limited to the repair or replacement of defective parts with the exceptions noted above.

At TMC's option any defective part or equipment which fails within the warranty period shall be returned to TMC's factory for inspection, properly packed with shipping charges prepaid. No parts or equipment shall be returned to TMC, unless a return authorization is issued by TMC.

No warranties, express or implied, other than those specifically set forth herein shall be applicable to any equipment manufactured or furnished by TMC and the foregoing warranty shall constitute the Buyers sole right and remedy. In no event does TMC assume any liability for consequential damages, or for loss, damage or expense directly or indirectly arising from the use of TMC Products, or any inability to use them either separately or in combination with other equipment or materials or from any other cause.

*Electron tubes also include semi-conductor devices.

PROCEDURE FOR RETURN OF MATERIAL OR EQUIPMENT

Should it be necessary to return equipment or material for repair or replacement, whether within warranty or otherwise, a return authorization must be obtained from TMC prior to shipment. The request for return authorization should include the following information:

1. Model Number of Equipment.
2. Serial Number of Equipment.
3. TMC Part Number.
4. Nature of defect or cause of failure.
5. The contract or purchase order under which equipment was delivered.

PROCEDURE FOR ORDERING REPLACEMENT PARTS

When ordering replacement parts, the following information must be included in the order as applicable:

1. Quantity Required.
2. TMC Part Number.
3. Equipment in which used by TMC or Military Model Number.
4. Brief Description of the Item.
5. The *Crystal Frequency* if the order includes crystals.

PROCEDURE IN THE EVENT OF DAMAGE INCURRED IN SHIPMENT

TMC's Warranty specifically excludes damage incurred in shipment to or from the factory. In the event equipment is received in damaged condition, the carrier should be notified immediately. Claims for such damage should be filed with the carrier involved and not with TMC.

All correspondence pertaining to Warranty Claims, return, repair, or replacement and all material or equipment returned for repair or replacement, within Warranty or otherwise, should be addressed as follows:

THE TECHNICAL MATERIEL CORPORATION
Engineering Services Department
700 Fenimore Road
Mamaroneck, New York

TABLE OF CONTENTS

Section		Page
1	GENERAL INFORMATION	1-1
	1-1. Functional Description	1-1
	1-2. Physical Description	1-1
	1-3. Technical Specifications	1-1
2	INSTALLATION	2-1
	2-1. General	2-1
	2-2. Power Requirements	2-1
	2-3. Mechanical Installation	2-1
	2-4. Electrical Installation	2-1
	2-5. Initial Checkout Procedure	2-2
3	OPERATOR'S SECTION	3-1
	3-1. General	3-1
	3-2. Controls and Indicators	3-1
	3-3. Operating Procedures	3-3
	3-4. Single Sideband With Any Degree of Carrier Insertion	3-3
	3-5. Independent Sideband With Any Degree of Carrier	3-4
	3-6. Conventional AM Operation	3-4
	3-7. Frequency Shift Telegraph Operation	3-4
	3-8. Facsimile (FAX) Operation	3-4
	3-9. CW Telegraph Operation	3-5
4	PRINCIPLES OF OPERATION	4-1
	4-1. Introduction	4-1
	4-2. Functional Block Diagram Description	4-1
	a. Carrier Generator Z104	4-1
	b. Upper and Lower Sideband Generators Z105 and Z109	4-1
	c. AM Amplifier Z108	4-2
	d. Frequency Shift Generator Z107	4-2
	e. Converter and ALDC, Z103	4-2
	f. RF Amplifier Z101, Z102 and Z111 Through Z113	4-2
	g. RF Output Z115 and Metering Circuit	4-2
	h. Power Supply Assembly	4-2
	4-3. Detailed Circuit Analysis	4-5
	a. Carrier Generator Z104	4-5
	b. Upper and Lower Sideband Generators Z105 and Z109	4-5
	c. Mode Switching	4-6
	d. Converter and ALDC, Z103	4-9
	e. AM Amplifier Z108	4-10
	f. Frequency Shift Generator Z107	4-10
	g. RF Amplifiers Z101, Z102 and Z111 Through Z113	4-12
	h. RF Output Z115 and Metering Circuit	4-12
	i. Power Supply Assembly	4-13
5	MAINTENANCE	5-1
	5-1. Preventive Maintenance	5-1
	a. Inspection and Test	5-1
	b. Cleaning Instructions	5-2

TABLE OF CONTENTS (Cont)

Section		Page
5	MAINTENANCE (continued)	
	5-2. Troubleshooting	5-2
	5-3. Alignment	5-5
	a. General	5-5
	b. Equipment Required	5-5
	c. Power Supply Boards Z303 and Z304	5-6
	d. Carrier Generator Z104	5-6
	e. Converter and ALDC Z103	5-6
	f. Upper Sideband Generator Z105	5-7
	g. Lower Sideband Generator Z109	5-7
	h. AM Amplifier Z108	5-7
	i. RF Amplifier Z101, Z102, and Z111 Through Z113	5-8
	j. Frequency Shift Generator Z107	5-9
	k. RF Output Z115	5-9
	l. Overall Check	5-9
	5-4. Repair of Printed Circuitry	5-10
	a. Introduction	5-10
	b. Replacement of Parts	5-10
	c. Checking Printed Circuit Conductors	5-10
	d. Repair of Printed Conductors	5-10
6	PARTS LIST	6-1
7	SCHEMATIC DIAGRAMS	7-1

LIST OF ILLUSTRATIONS

Figure	Title	Page
1-1	Sideband Multi-Channel Exciter, SME-6	1-0
2-1	Tilt-Lock Slide Mechanism	2-1
2-2	Rear Panel Connectors	2-2
2-3	Front Panel Monitor Indicators	2-3
3-1	Operating Controls, Indicators and Connectors	3-2
4-1	SME-6, Functional Block Diagram	4-3
4-2	Audio Mode Switching, Simplified Schematic	4-7
4-3	CW, FSK and FAX Mode Switching, Simplified Schematic	4-8
4-4	Frequency Shift Keyer Circuit, Simplified Schematic	4-11
5-1	SME-6, Top View, Location of Major Components	5-3
5-2	SME-6, Bottom View, Location of Major Components	5-4
5-3	Power Supply Board, Test Setup	5-6
5-4	Audio and AM Amplifier, Test Setup	5-7
5-5	Sideband Generator Z105, Test Setup	5-7
5-6	Frequency Shift Generator Adjustment Locations	5-9
5-7	RF Output Waveform	5-11
5-8	Carrier Generator Z101, Component Location	5-11
5-9	Sideband Generators Z105 and Z109, Component Location	5-11
5-10	AM Amplifier Z108, Component Location	5-12
5-11	Frequency Shift Generator Z110, Component Location	5-12
5-12	Converter and ALDC Z103, Component Location	5-13
5-13	RF Amplifier Z101, Z102, Z111, Z112 and Z113, Component Location	5-13
5-14	RF Output Z115, Component Location	5-14
5-15	Rectifier-Filter Z304, Component Location	5-15
5-16	Regulator Z303, Component Location	5-15

LIST OF TABLES

Table	Title	Page
2-1	Rear Panel Connections	2-3
3-1	Functions of Controls, Indicators and Connectors	3-1
4-1	RF Output Frequency Bands vs Frequency Selector Switch Positions	4-12
5-1	Weekly Inspection Routine	5-1
5-2	Troubleshooting Chart	5-2
5-3	FAX Voltage vs Frequency Linearity Check	5-9
7-1	List of Schematics	7-1



Figure 1-1. Sideband Multi-Channel Exciter, SME-6

SECTION 1

GENERAL INFORMATION

1-1. FUNCTIONAL DESCRIPTION

This manual presents operating and maintenance instructions for Sideband Multi-Channel Exciter, Model SME-6, designed and manufactured by The Technical Materiel Corporation, Mamaroneck, New York. The manual includes a general description of the equipment, installation and operating instructions, principles of operation, maintenance data and a parts list.

Sideband Multi-Channel Exciter, Model SME-6 (figure 1-1) hereinafter referred to as the Exciter, or the SME-6, is a solid state exciter that is used to control the output frequency of a transmitter in the CW mode of operation over a frequency range of 1.6 MHz to 30 MHz by the incorporation of nine plug-in coil assemblies. Rapid tuning within this frequency range is accomplished by selecting one of ten available preset crystal-controlled channels for continuous wave (CW) and the optional modes of upper sideband (USB), lower sideband (LSB), independent sideband (ISB), amplitude modulation (AM), frequency shift keying teletype (FSK), and facsimile (FAX).

Front panel controls permit operator selection of the operating mode and operating channel (1-10). Additional controls are included on the front panel to select the degree of carrier suppression desired (0, -6 db, -26 db, FULL (-55 db) or continuously adjustable from 0 to -55 db), voice operated mode gain (VOX), mike gain, rf output level and LSB and USB gain, when the options are included. Two front panel jacks permit a 55 dbm low impedance microphone and a dry contact keyer input to be coupled to the Exciter. A front panel ammeter, used in conjunction with the meter select switch, enables the operator to select and monitor one of four circuits: LSB, USB, CARR, or RF. Selection of exciter or press to talk (PTT) operation is accomplished by a front panel selector switch.

Standard BNC connectors are provided on the rear panel of the Exciter to interface the standard 1 MHz output frequency, 1 MHz monitor, Automatic Load and Drive Control (ALDC) circuit, rf output and rf monitor with the external equipment. The remaining interface connections with the external equipment are made at three rear panel mounted terminal boards. These connections are detailed in Section 2, Installation.

NOTE

The terms MHz, kHz and Hz, as used herein, represent megacycles (Mc, kilocycles (Kc) and cycles (cps) respectively.

1-2. PHYSICAL DESCRIPTION

The majority of the electronic components which constitute the Exciter are mounted on 12 circuit boards that plug into Cinch connectors mounted on the chassis. Two additional printed circuit boards, Z303 and Z304, are included as part of the power supply assembly. An extender card, which mates with the individual printed circuit boards and the Cinch connectors, is supplied with the Exciter to facilitate maintenance, alignment, and troubleshooting procedures.

1-3. TECHNICAL SPECIFICATIONS

FREQUENCY RANGE:	1.6 - 30 MHz by plug-in RF Modules with plug-in coil assemblies covering the following frequency ranges: 1.6-2.0, 2.0-3.0, 3.0-4.0, 4.0-6.0, 6.0-8.0, 8.0-12, 12-16, 16-24, and 24-30.
MODE OF OPERATION:	CW
OPTIONAL MODES OF OPERATION:	USB, LSB, ISB, AM, FSK/FAX
POWER OUTPUT:	0 to 250 milliwatts PEP adjustable from the front panel. Optional remote control.
OUTPUT IMPEDANCE:	Nominal 50 ohms unbalanced.
TUNING:	Ten preset crystal-controlled channels over the range of 1.6 to 30 MHz.
FREQUENCY STABILITY:	Temperature controlled crystal oscillator for maximum of ± 50 Hz over ambient temperature range of 0° C to $+50^{\circ}$ C, or proportional controlled oven for 10 Hz over range of -30° C to $+50^{\circ}$ C.
SIGNAL/DISTORTION RATIO:	Distortion products are at least 40 db below either tone of a two tone test at 250 milliwatts PEP output.

UNWANTED SIDEBAND REJECTION:	Better than 50 db down at full PEP output.
SPURIOUS SIGNALS:	Better than 60 db down at full PEP output.
NOISE LEVEL:	Better than 60 db down at full PEP output.
CARRIER INSERTION:	Continuously adjustable from 0 db to at least -55 db below Peak Envelope Power (PEP). Front panel controls permit carrier suppression of 0 db, -6 db, -26 db or full.
AUDIO RESPONSE:	2 db, 300 Hz to 7.5 kHz in AM mode. 2 db, 300 to 3300 Hz in sideband mode. Filter options: 2 db, 250 to 3040 Hz. 2 db, 250 to 6080 Hz.
AUDIO INPUT:	-20 to +10 dbm at 600 ohms balanced or unbalanced input, with push-to-talk or VOX control or front panel -55 dbm Low Impedance microphone.
OVERLOAD LIMIT:	Each audio channel contains a special built-in circuit which prevents overloading the transmitter.
VOICE OPERATED RELAY:	Voice controlled switch with adjustable threshold.

CW KEYING:	Front panel jack or rear panel dry contact keying circuit at 200 bauds.
FSK INPUT KEYING:	20 or 60 milliamperes, 50 or 100 volts or dry contact keying.
FSK SHIFT:	±425, ±212, ±106, ±53 Hz.
FSK KEYING SPEED:	200 bauds.
FAX INPUT:	+1 to +10 volts for frequency shift of ±500 Hz.
METERING:	Front panel metering of Q1, Q2, Q3, LSB, USB, carrier and rf output.
ENVIRONMENTAL CONDITIONS:	Designed to operate in an ambient temperature range of 0° C to 50° C at any value of relative humidity up to 95%. Operation to -30° C optional.
STORAGE CONDITIONS:	Equipment is not materially affected by storage at -40° C to +85° C at relative humidity of 95%.
SAFETY FEATURES:	AC power input fused.
EQUIPMENT SUPPLIED:	Mating plugs, connectors, and instruction manual.

SECTION 2
INSTALLATION

2-1. GENERAL

The Exciter is calibrated and tested at the factory prior to shipment. When the Exciter is received at the operating site, inspect the packing case and contents for possible damage that might have occurred during transit. Unpack the equipment carefully, and inspect all packaging material for parts that have been shipped as loose items. With respect to damage of the equipment for which the carrier is liable, The Technical Materiel Corporation will assist in describing methods of repair and furnishing of replacement parts.

2-2. POWER REQUIREMENTS

CAUTION

Set ON/STANDBY switch (figure 3-1, 8) to STANDBY; when line cord is connected to appropriate power source, voltage is extended through the power supply components.

The Exciter is designed for 115/230 vac, 50/60 Hz, single phase power operation. Unless specifically ordered otherwise, the unit is shipped for 115 vac operation. For 230 vac operation, wiring changes must be made, as shown in figure 7-10. For 230 vac operation, replace line protective fuses with fuses having 1/2 the 115 vac fuse rating.

2-3. MECHANICAL INSTALLATION

The Exciter is equipped with a standard 19-inch wide front panel. To install the unit in an equipment rack, fasten the front panel to the rack with four screws and four washers (supplied).

When the Exciter is equipped with a tilt-lock slide mechanism, installation is as follows. (See figure 2-1.)

- a. Pull out the center sections of the tracks, located in the equipment rack, until they lock in extended position.
- b. Position the slide mechanisms of the unit in the tracks, and ease the unit into the rack until the release fingers engage the holes in the tracks.
- c. Press the release fingers and slide the unit completely into the rack. Secure the front panel of the unit to the rack with screws and washers.
- d. Make the necessary electrical connections, as described in paragraph 2-4.

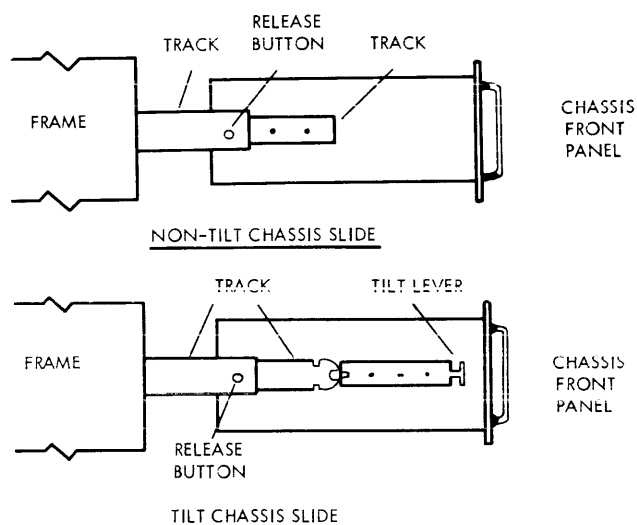

Figure 2-1. Tilt-Lock Slide Mechanism

2-4. ELECTRICAL INSTALLATION

All electrical connections between the Exciter and associated equipment are made at the rear of the unit. Figure 2-2 illustrates all rear panel connections, while table 2-1 lists the panel designation and function of each connection.

TABLE 2-1. REAR PANEL CONNECTIONS

Panel Designation	Function
J116 (POWER)	Power input for 115 vac or 230 vac line power
J119 (Remote Input)	Optional input connector for remote control operation
J120 (1 MHz OUT)	1 MHz standard output jack
J121 (1 MHz MON)	1 MHz standard monitor jack
J123 (ALDC)	Input from an associated linear amplifier to improve linearity, limit distortion and deliver a relatively constant output level during high modulation peaks or load changes
J124 (RF OUT)	RF output jack

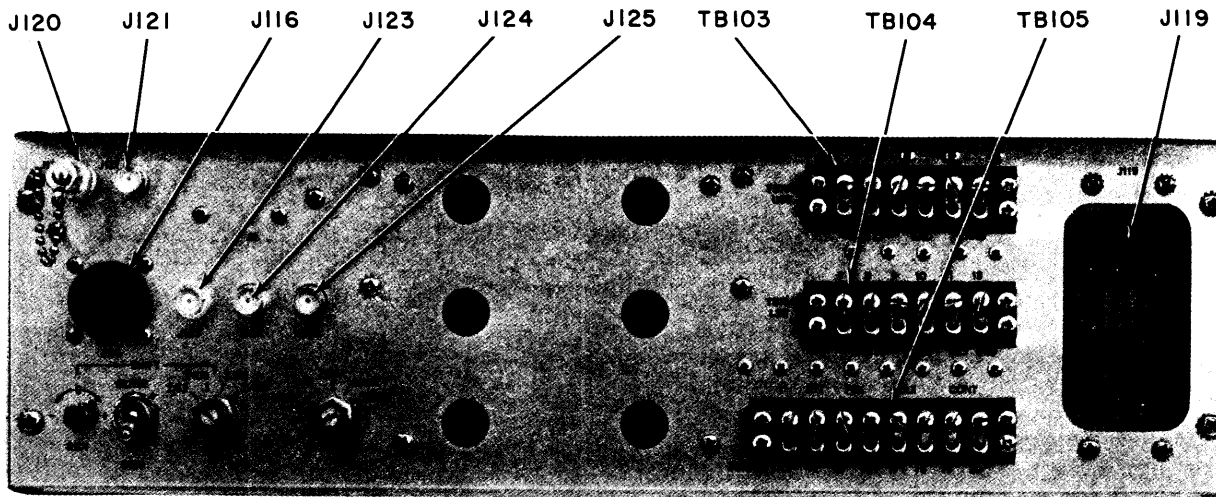

Figure 2-2. Rear Panel Connections

TABLE 2-1. REAR PANEL CONNECTIONS (Cont)

Panel Designation	Function
J125 (RF MON)	RF output monitor jack
TB103 (USB) -1, -2, -3	USB 600-ohm balanced input
-4	Ground terminal
-5, -6	TRANS terminals for connecting PTT relay contacts to external equipment
TB104 (LSB) -7, -8, -9	LSB 600-ohm balanced input
-10	Ground terminal
-11	Keyer input terminal for CW keying
-12	Ground terminal for CW keying
TB105 -13, -14	Provides a ground for PTT relay through external equipment
-15, -16	FSK inputs for FSK transmission (TTY) battery loop

TABLE 2-1. REAR PANEL CONNECTIONS (Cont)

Panel Designation	Function
TB105 (cont) -17, -18 -19, -20	FAX input Dry contact input for FSK mode of operation

2-5. INITIAL CHECKOUT PROCEDURE (See figures 2-2 and 2-3.)

Although the Exciter has been aligned and thoroughly checked against the manufacturer's specifications prior to shipment, it is necessary to ensure correct installation and proper Exciter operating conditions by performing the following checkout procedures. Refer to Section 3 for location and functions of all operating controls and indicators.

NOTE

Unless otherwise indicated, item numbers (numbers in parentheses) are callouts referred to figure 3-1.

- a. Set ON/STANDBY switch (10) to STANDBY position.
- b. Connect source of 115 vac line power to connector J116 (figure 2-2). STANDBY indicator (9) shall illuminate amber.

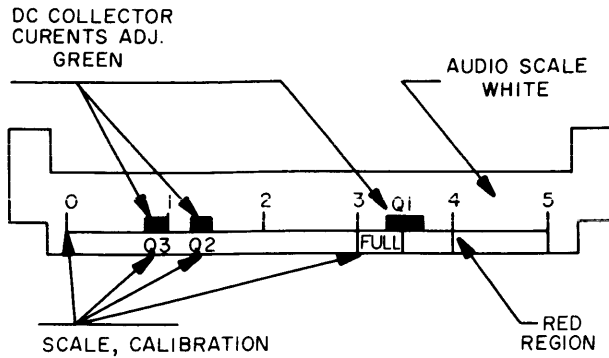

Figure 2-3. Front Panel Monitor Indicators

c. Set RF OUTPUT control (2) fully counterclockwise.

d. Set CARR SUPPR (DB) controls (13) and (14) to fully counterclockwise and 0 positions, respectively.

e. Set MODE switch (3) to USB position.

f. Set MIKE GAIN (7) and VOX GAIN (5) to OFF.

g. Set USB control (17) and LSB control (18) fully counterclockwise.

h. Set EXCITER switch (12) to ON.

i. Connect Hewlett-Packard Model 200CD Audio Generator (or equivalent), to USB 600-ohm terminals (TB103) and LSB 600-ohm terminals (TB104), located on rear panel of Exciter. Set audio frequency for 1000 Hz at 10 volts.

j. Set ON/STANDBY switch (10) to ON. Standby indicator (9) shall extinguish and POWER indicator (11) shall illuminate red.

k. Set METER switch (3) to Q1 position. MONITOR meter (6) shall indicate in the green region marked Q1. (See figure 2-3.)

l. Set METER switch (3) to Q2 position. MONITOR meter (6) shall indicate in the green region marked Q2. (See figure 2-3.)

m. Set METER switch (3) to Q3 position. MONITOR meter (6) shall indicate in the green region marked Q3. (See figure 2-3.)

n. Set METER switch (3) to RF position. MONITOR meter (6) shall indicate zero with RF OUTPUT control (2) fully counterclockwise.

o. Connect a VTVM (Hewlett-Packard Model 410B, or equivalent) to RF OUT jack J124 (figure 2-2) across a 50-ohm load resistor. Adjust RF OUTPUT control (2) until VTVM indicates 3.5 volts.

p. Set METER switch (3) to USB position. Adjust USB gain control (17) for an indication of 4/5 full scale on MONITOR meter (6).

q. Set METER switch (3) to LSB position. Adjust LSB gain control (18) for an indication of 4/5 full scale on MONITOR meter (6).

r. Set CARR SUPPR (DB) control (14) to VAR and set METER switch (3) to CARR position; adjust carrier to desired level on MONITOR meter (6) using CARR SUPPR (DB) control (13).

s. To verify proper AM operation, set MODE switch (15) to AM. Set EXCITER switch (12) to ON; MONITOR meter (6) shall indicate approximately 0.7.

t. Disconnect all test equipment.

SECTION 3
OPERATOR'S SECTION

3-1. GENERAL

The Exciter provides CW operation over a frequency range of 1.6 MHz to 30 MHz. The Exciter is used to control the output frequency of a transmitter in the CW mode of operation. Standard options are available to control the output frequency of a transmitter in the USB, LSB, ISB, AM and FSK/FAX modes of operation.

3-2. CONTROLS AND INDICATORS (See figure 3-1)

All operator controls, indicators and connectors are located on the front and rear panel of the Exciter. Figure 3-1 illustrates the locations of all operator controls, indicators and connectors, while table 3-1 lists the controls, indicators and connectors and provides the panel designation and function of each.

TABLE 3-1. FUNCTIONS OF CONTROLS, INDICATORS AND CONNECTORS

Item Number (figure 3-1)	Panel Designation	Function
1	MIKE jack	Accepts a -55 dbm low impedance microphone input
2	RF OUTPUT control	Adjusts rf output level
3	METER switch (seven position):	
	Q1	Displays rf output transistor Q1 collector current (350 ma) on MONITOR meter
	Q2	Displays rf output transistor Q2 collector current (130 ma) on MONITOR meter
	Q3	Displays rf output transistor Q3 collector current (65 ma) on MONITOR meter
	LSB	Displays LSB output level on MONITOR meter
	USB	Displays USB output level on MONITOR meter
	CARR	Displays carrier level on MONITOR meter
	RF	Displays RF level on MONITOR meter
4	SPARES (2) fuses	Spare 1 amp line voltage fuses
5	VOX control	Regulates the sensitivity of the voice control circuit
6	MONITOR meter	Monitors circuit selected by METER switch
7	MIKE GAIN control	Adjusts gain of mike input
8	LINE (2) fuses	1 amp line voltage fuses
9	STANDBY indicator	Illuminates amber when ON/STANDBY switch is positioned to STANDBY
10	ON/STANDBY switch	When positioned to ON, applies 12 and 24 vdc to modules. When positioned to STANDBY, removes dc voltages from modules and illuminates STANDBY indicator

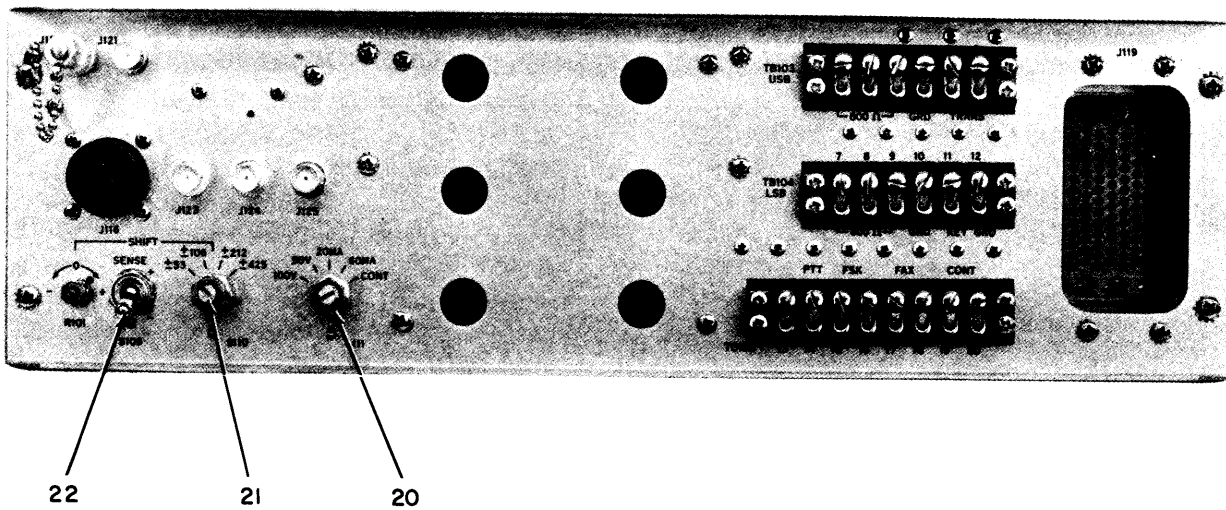
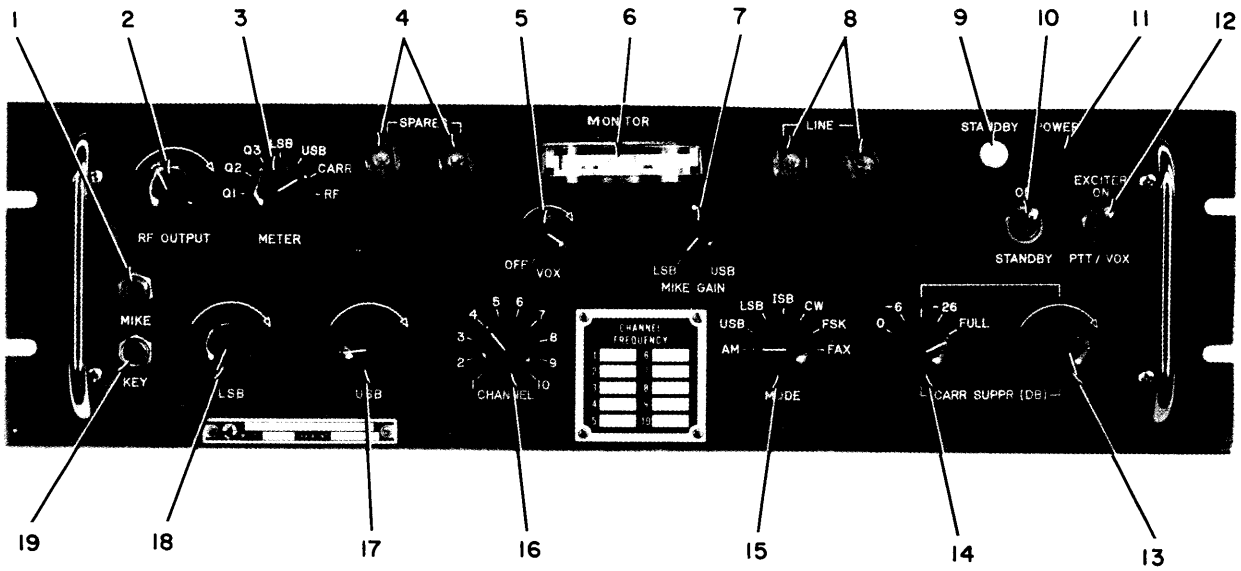

Figure 3-1. Operating Controls, Indicators and Connectors

TABLE 3-1. FUNCTIONS OF CONTROLS, INDICATORS AND CONNECTORS (Cont)

Item Number (figure 3-1)	Panel Designation	Function
11	POWER indicator	Illuminates red when ON/STANDBY switch is positioned to ON
12	EXCITER ON/PTT switch	Set to ON for all modes of operation using inputs other than MIKE. Set to PTT when using MIKE input.
13	(DB) control	Continuously adjustable from 0 db to at least -55 db below PEP when CARR SUPPR control is set to mid-position
14	CARR SUPPR control	Permits carrier suppression of 0, -6, -26, FULL, or continuously adjustable when set to mid-position
15	MODE switch (seven position)	Establishes one of seven operating modes, depending upon options supplied: AM, USB, LSB, ISB, CW, FSK or FAX
16	CHANNEL switch	Permits the selection of one of ten preset channels
17	USB control	Adjusts USB gain
18	LSB control	Adjusts LSB gain
19	KEY jack	Accepts dry contact keyer input used for CW mode of operation
20	FSK keying input switch (five positions)	Selects proper FSK loop input: 100V, 50V, 20MA, 60MA, or CONT
21	SHIFT switch (four positions)	Determines the "mark" and "space" frequency shift above and below the carrier frequency: 53, 106, 212, or 425 Hz
22	SENSE switch (two position)	Establishes sense + (positive) or - (negative) in the FSK mode of operation

3-3. OPERATING PROCEDURE

Before initially placing the Exciter in operation, perform the initial checkout procedure outlined in Section 2, Installation. To place the Exciter in operation:

NOTE

Verify that ON/STANDBY switch (10, figure 3-1) is set to STANDBY.

a. Connect a source of 115 vac, single-phase power to connector J116 (figure 2-2). Observe that STANDBY indicator (9) illuminates amber.

b. Make necessary interface connections on rear panel jack (figure 2-2).

3-4. SINGLE SIDEBAND WITH ANY DEGREE OF CARRIER INSERTION

a. Set ON/STANDBY switch (10) to ON.

b. Set EXCITER switch (12) to ON position when using either the USB or LSB 600-ohm line inputs. Set EXCITER switch to PTT position when using MIKE input (1).

c. Select desired sideband with MODE switch (15).

d. Select desired operating frequency with CHANNEL selection switch (16).

e. Turn METER switch (3) at the desired sideband.

f. Connect a Mike to the front panel MIKE jack (1) if used.

g. Adjust the GAIN control of sideband used until indication of 4/5 full scale is obtained on MONITOR (6).

NOTE

DO NOT ENTER RED REGION.
When mike input is used, adjust level so as not to exceed red region with highest input from microphone.

h. Turn METER switch (3) to CARR position. Set CARR SUPPR (DB) control (14) to center position. Adjust control (13) to the desired level as indicated on MONITOR meter (6).

i. Turn METER switch (3) to RF position. Adjust RF OUTPUT control (2) for desired level of RF output as indicated on MONITOR meter (5).

NOTE

Turn RF OUTPUT control (2) fully CCW before selecting different modes of operation.

3-5. INDEPENDENT SIDEBAND WITH ANY DEGREE OF CARRIER

a. Set ON/STANDBY switch (10) to ON position.

b. Set EXCITER switch (12) to ON position when using either the USB or LSB 600-ohm line inputs. Set EXCITER switch (12) to PTT position when using a MIKE input (1).

c. Set USB (17) and LSB (18) controls to zero.

d. Select ISB position on MODE switch (15).

e. Select desired operating frequency with CHANNEL selection switch (16).

f. Turn METER switch (3) to LSB position. Adjust the LSB GAIN control (18) for a MONITOR meter (6) indication of up to but not to exceed the red region.

g. Turn METER switch (3) to USB position. Adjust USB GAIN control (17) for a MONITOR meter (6) indication of up to but not to exceed the red region.

h. Turn METER switch (3) to the CARR position. Set CARR SUPPR (DB) control (14) to center position. Adjust control (13) to full or the desired level as indicated on MONITOR meter (6).

i. Turn METER switch (3) to the RF position and adjust RF OUTPUT control (2) for the level of RF output indicated on MONITOR meter (6).

3-6. CONVENTIONAL AM OPERATION

a. Set ON/STANDBY switch (10) to ON position.

b. Set EXCITER switch (12) to ON position when using either the USB or LSB 600-ohm line input. Set EXCITER switch to PTT position when using MIKE input (1).

c. Set MODE switch (15) to AM position.

d. Select desired operating frequency with CHANNEL selection switch (16).

e. Turn METER switch (3) to AM position.

f. Connect a mike to the front panel MIKE jack (1) if used.

g. Adjust the MIKE control (7) until indication of 4/5 full scale is obtained on MONITOR meter (6).

NOTE

DO NOT ENTER RED REGION.
When mike input is used, adjust level so as not to exceed red region with highest input from microphone.

h. Turn METER switch (3) to RF position and adjust RF OUTPUT control (2) for desired level of RF output as indicated on MONITOR meter (6).

3-7. FREQUENCY SHIFT TELEGRAPH OPERATION.

a. Set ON/STANDBY switch (10) to ON position.

b. Set EXCITER switch (12) to ON position.

c. Turn MODE switch (15) to FSK position.

d. Set CHANNEL switch (16) to desired position.

e. Select appropriate FSK operation by setting SHIFT switch (21) and LOOP switch (20).

f. Place SENSE switch (22) to desired sense (+) or (-).

g. Place METER switch (3) to the RF position. Adjust RF OUTPUT control (2) for desired MONITOR (6) reading.

3-8. FACSIMILE (FAX) OPERATION

a. Set ON/STANDBY switch (10) to ON position.

b. Set EXCITER switch (12) to ON position.

c. Turn MODE switch (15) to FAX position.

d. Set CHANNEL switch (16) to the desired frequency.

e. Place METER switch (3) to the RF position. Adjust RF OUTPUT control (2) for desired MONITOR (6) reading.

3-9. CW TELEGRAPH OPERATION

- a. Set ON/STANDBY switch (10) to ON position.
- b. Set MODE switch (15) to CW position.
- c. Connect key to KEY input (19).

SECTION 4

PRINCIPLES OF OPERATION

4-1. INTRODUCTION

The principles of operation for the SME-6 is presented in two parts: The first part discusses SME-6 operation with reference to an overall functional block diagram, while the second part presents a detailed description of the individual SME-6 circuits and is referenced to applicable simplified diagrams, and to the interconnection and schematic diagrams contained in Section 7.

4-2. FUNCTIONAL BLOCK DIAGRAM DESCRIPTION (See figure 4-1)

The SME-6 is an rf exciter capable of providing amplitude-modulated (AM) operation; single sideband suppressed carrier (SSSC) or conventional single sideband (SSB) operation; independent sideband (ISB) operation; continuous wave (CW) keyed operation; frequency shift keyer (FSK) operation; and facsimile (FAX) operation. The Exciter includes upper and lower sideband generators; a carrier generator; an AM amplifier; a frequency shift generator; an rf converter and ALDC circuit; a brace of five rf amplifiers for multi-channel operation; an rf output circuit; and a mode-switching network. Provisions are also included for remote control operation via a rear panel control connector and control relay.

a. **CARRIER GENERATOR Z104.** The carrier generator develops a basic subcarrier frequency of 250 kHz, and a 1.666 MHz carrier frequency used for translation to an rf output frequency band; it also contains a meter amplifier circuit for upper and lower sideband audio translation to an equivalent level for display on the MONITOR meter when USB or LSB audio is selected by METER switch.

The carrier generator receives a 1 MHz standard frequency input of 1 MHz from the power supply assembly, which is supplied to both the 250 kHz and 1.666 MHz frequency generation circuits. In the 250 kHz channel, the 1 MHz input is divided by 4 to derive the basic 250 kHz subcarrier frequency; a switched ground enable is applied from the mode switching network in the AM, USB, LSB, ISB, CW, and FSK modes to enable a 250 kHz subcarrier output signal. In the CW mode, the ground enable is interrupted at the key rate, thereby producing a 250 kHz CW output. The 250 kHz output is applied to the mode switching network for distribution to the various sections of the Exciter in accordance with the MODE switch setting, and to the CARR SUPP switch network for carrier reinsertion, when desired. In the FAX mode, the 250 kHz channel is disabled.

The 1.666 MHz channel produces an rf output by multiplying the 1 MHA input by 5 and then dividing the resultant by 3 to derive the 1.666 MHz rf translation frequency. Switched +12 vdc to this

channel is controlled by the MODE switch S2 and is present in the AM, USB, LSB, ISB and CW positions. The 1.666 MHz output is supplied to the converter and ALDC circuit, Z103, for translation to a resultant 1.416 MHz rf carrier.

b. **UPPER AND LOWER SIDEBAND GENERATORS Z105 AND Z109.** The upper and lower sideband generators are similar in circuit configuration and operation; the exception is the tuned frequency of the USB and LSB amplifier circuits. The sideband generator contains a microphone audio preamplifier; an audio impedance-matching transformer for translation of externally applied 600-ohm line audio to a 500-ohm audio output; an SSB modulation circuit; a voice-operated audio (VOX) circuit for keying of the sideband audio intelligence; and an automatic gain control (AGC) circuit.

When a microphone input is used, the front panel EXCITER switch is set to the press-to-talk (PTT) position to furnish a PTT ground enable to the carrier generator via the mode switching network; in all other modes, the EXCITER switch is set to the ON position, which supplies a permanent ground. Microphone audio from 300 Hz to 7.5 kHz is applied to the sideband generator audio preamplifier circuit, and then to the mode switching network for re-distribution to either, or both, of the sideband generator modulator circuits. Similarly, 600-ohm line audio from 300 Hz to 3.3 kHz is translated to a 500-ohm line output and applied to the mode switching network. In the USB, LSB and ISB modes, the audio is routed to the modulation input of the respective, or each, sideband generator; in the AM mode, the respective audio signal is applied to AM amplifier Z108. USB and LSB audio amplitude is controlled by a respective front panel GAIN control. In addition, the audio is developed across both the MIKE GAIN control, to provide microphone feedback boost, and the VOX GAIN control, to set the VOX audio input level to the sideband generator. Therefore, whenever an audio input is present, VOX audio is generated.

The SSB modulation section of the sideband generator accepts both a 250 kHz subcarrier input and the USB/LSB audio signal via the MODE switch. These two signals are applied to a balanced modulator to derive the upper and/or lower sideband intelligence; the 250 kHz subcarrier is suppressed. The resulting USB and/or LSB signals are supplied to the mode switching network and are then routed to converter and ALDC circuit Z103. The AGC circuit maintains the SSB output signal within nominal limits as set by an internal threshold adjustment. In addition, the SSB signal is gated by the VOX input signal and thus occurs only when audio intelligence is present. The VOX audio input is translated to a proportional dc level and is used to energize the PTT relay which, in turn, applies a ground enable to the gate circuit, thereby gating the USB and/or LSB signal to the mode switching network.

c. **AM AMPLIFIER Z108.** The AM amplifier develops an amplitude-modulated 250 kHz signal in the AM mode of operation, and consists of an audio amplifier and mixer circuit. In the AM mode, USB and/or LSB audio is routed to the audio amplifier stage and then to the mixer; the 250 kHz subcarrier is applied directly to the mixer. The resultant amplitude-modulated 250 kHz signal is then routed through the AM position of the MODE switch to converter and ALDC circuit Z103.

d. **FREQUENCY SHIFT GENERATOR Z107.** The frequency shift generator operates in the frequency shift keyer (FSK) and facsimile (FAX) modes; it contains a 1.4166 MHz amplifier section, a keyer-modulator and dc amplifier section, and the FAX circuit. FSK operation is controlled by the SHIFT and FS LOOP switches.

In the FSK mode, the 250 kHz subcarrier is applied to the keyer modulator, which also receives an external teletype input via the FS LOOP switch. Therefore, the subcarrier is effectively modulated by a current input representing teletype marks and spaces; the FS loop switch network is set to the appropriate voltage rating and when a dry-contact keyer is used the switch is set to the contact (CONT) position. The keyer-modulator thus produces a shift in frequency above and below the 250 kHz center frequency. This shift is rectified and translated to a dc level, which is amplified and applied to the 1.4166 MHz variable crystal-controlled oscillator (VXCO) in the power supply assembly via the SHIFT switch network.

When FSK or FAX operation is selected, +12 vdc is supplied to both the frequency shift generator and to the VXCO in the power supply assembly. As a result, the VXCO operates at the center frequency of 1.4166 MHz. Upon application of the variable dc level (E MOD) from the SHIFT switch, the frequency of the VXCO is shifted above and below center frequency, corresponding to respective marks and spaces, by an amount determined by SHIFT switch setting (± 53 , ± 106 , ± 212 , ± 425). The frequency-shifted VXCO signal of 1.4166 MHz is re-applied to the 1.4166 MHz amplifier section of the frequency shift generator and then to the converter and ALDC circuit, Z103.

In the FAX operation, an externally applied FAX signal produces a variable dc level through a dc regulator circuit; this level is applied to the VXCO to produce the required frequency shift.

e. **CONVERTER AND ALDC, Z103.** The converter section of Z103 accepts the 1.666 MHz carrier from carrier generator Z104; the 250 kHz AM, USB, LSB, ISB or CW input from the mode switching network; and the 1.4166 MHz VXCO input from frequency shift generator Z107.

In the AM mode, the 1.666 MHz carrier and the amplitude-modulated 250 kHz signal are mixed in a balanced modulator to produce a difference amplitude-modulated carrier of 1.416 MHz, which is developed across the front panel RF OUTPUT

control. In the USB, LSB and ISB modes, the input signals consist of the 1.666 MHz carrier and USB and/or LSB audio with, or without, the 250 kHz signal, depending upon the amount of carrier suppression introduced by the CARR SUPP switch network. This switch permits zero, partial or full carrier reinsertion by attenuating the 250 kHz input from the mode switching network. The carrier may be partially attenuated to 6 or 26 db below the audio intelligence level; continuously variable carrier suppression is provided with the CARR SUPP switch in the (VAR) position. The attenuated 250 kHz subcarrier from the CARR SUPP switch network is applied to the mode switching network, where it is reinserted with the USB and/or LSB audio as a pilot carrier prior to being sent to the converter and ALDC circuit, Z103. Therefore, the 250 kHz USB, LSB or ISB signal is mixed with the 1.666 MHz carrier to again produce a single sideband or independent sideband output with a 1.416 MHz center frequency.

In the CW mode, the 250 kHz input is interrupted at the keyer rate and thus results in a 1.416 MHz CW output. In the FSK and FAX modes, the 250 kHz and 1.666 MHz inputs are not present; the only input is the 1.4166 MHz VXCO signal from frequency shift generator Z107, which is developed across the RF OUTPUT control.

f. **RF AMPLIFIER Z101, Z102 AND Z111 THROUGH Z113.** Each of the five rf amplifiers accept the 1.416 MHz signal from the RF OUTPUT control, and translates this signal to an odd or even rf frequency band, within the range of 1.6 to 30 MHz, under control of the CHANNEL SELECTOR switches.

The CHANNEL SELECTOR switch distributes +24 vdc to the odd or even channels of each amplifier according to the channel numbers 1 through 10. Each channel of each amplifier incorporates a plug-in crystal-controlled local oscillator which operates above the incoming signal, and which is enabled by the switched +24 vdc input. When enabled, the local oscillator in question is mixed with the incoming 1.416 MHz signal from the RF OUTPUT control, resulting in a difference frequency which is amplified, filtered and applied to rf output circuit Z115. The frequency value of each crystal-controlled oscillator depends upon customer requirements, and the specific rf output band desired.

g. **RF OUTPUT Z115 AND METERING CIRCUIT.** The selected rf output frequency band from the rf amplifiers is amplified in rf output section Z115 and applied to the RF OUTPUT jack on the rear panel. A metering circuit is included to monitor the collector currents of the three amplifiers in this circuit; the USB and LSB audio signal levels; the amplitude of the carrier; and the rf output level of the selected frequency range. These parameters are controlled by the METER switch and displayed on the MONITOR meter in the Q1, Q2, Q3, USB, LSB, CARR and RF positions.

h. **POWER SUPPLY ASSEMBLY.** The SME-6 power supply operates from either 115 or 230 vac when the power transformer is properly wired. The

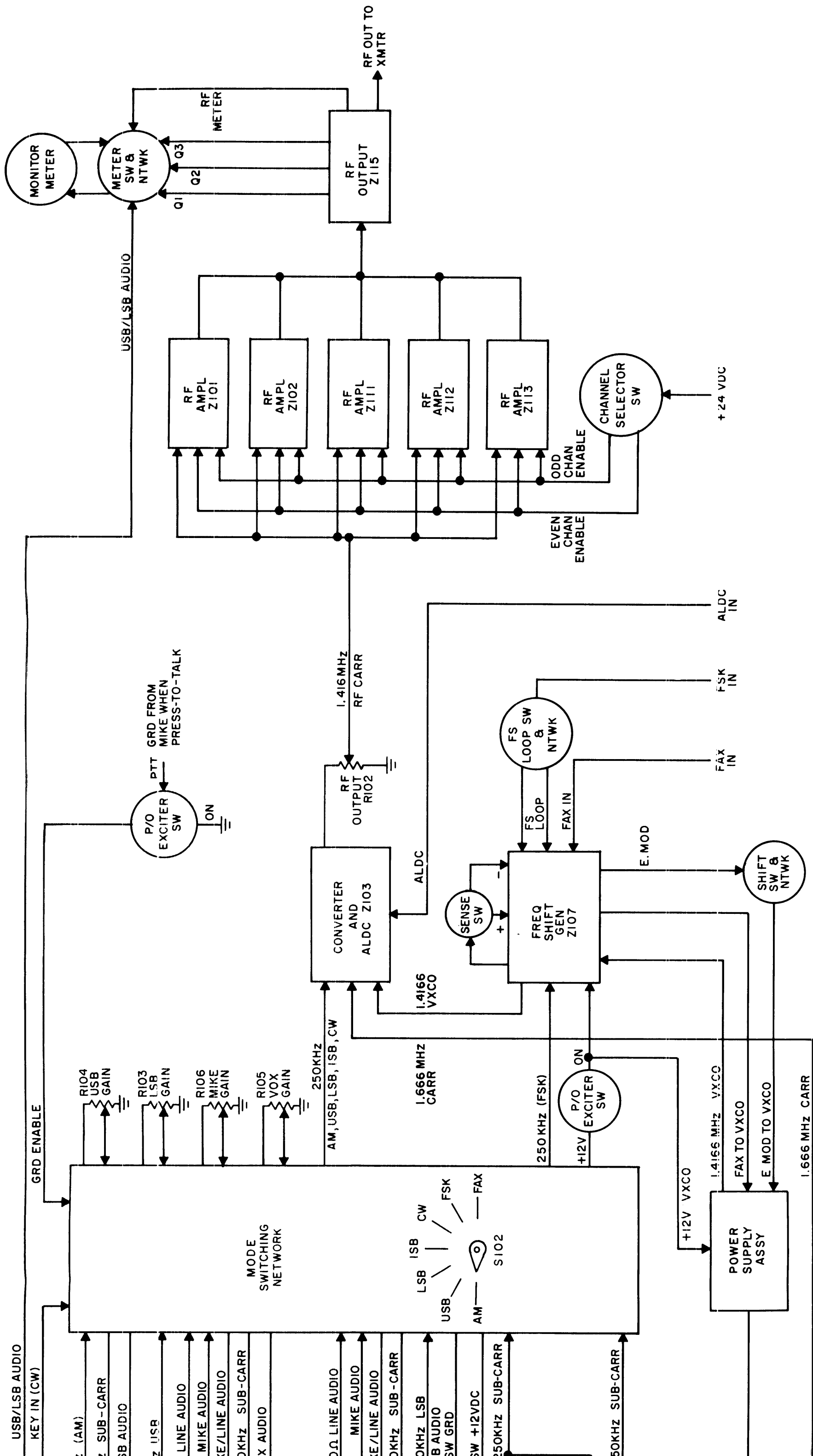
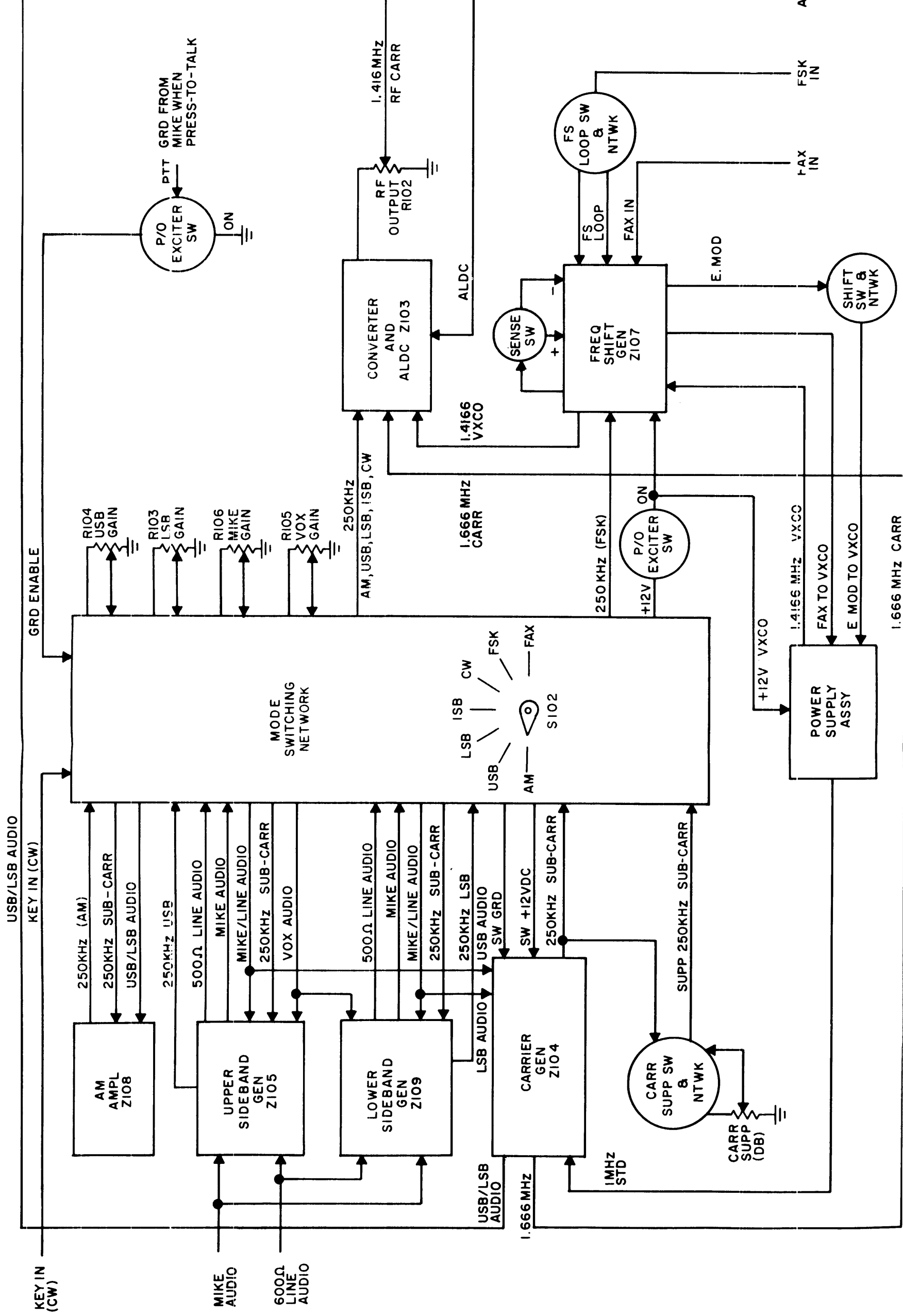

Figure 4-1. SME-6, Functional Block Diagram

005692045



power supply outputs regulated dc voltages of +30, +24 and +12 volts for operation of the Exciter circuits. The +24 and +12 vdc outputs are applied to the STANDBY position of the STANDBY-POWER switch and are distributed throughout the Exciter when set to the POWER position. The 1 MHz and 1.416 MHz frequency standards are produced by crystal-controlled oscillators; the 1 MHz signal is applied to the carrier generator, while the 1.416 MHz signal, enabled in the FSK and FAX modes, is applied to the frequency shift generator.

4-3. DETAILED CIRCUIT ANALYSIS

The following paragraphs present a detailed description of the circuits used to implement amplitude-modulated (AM), single sideband (USB/LSB), independent sideband (ISB), continuous wave (CW), frequency shift keyer (FSK) and facsimile (FAX) operation in the SME-6. The circuit descriptions are referenced to applicable simplified diagrams, and to the interconnection and schematic diagrams in Section 7.

a. **CARRIER GENERATOR Z104.** (See figure 7-2.) The carrier generator performs the function of producing a 250 kHz subcarrier frequency and a 1.666 MHz carrier frequency for formulation of a desired SSB or ISB rf transmission signal on one of 10 selected rf channels. The 250 kHz subcarrier and 1.666 MHz carrier is derived from the 1 MHz standard oscillator in the power supply assembly. In addition, the carrier generator circuit includes a metering amplifier circuit for conversion of the USB and LSB audio signals to a proportional dc level for display on the front panel MONITOR meter.

(1) In the 250 kHz channel of Z104, the 1 MHz standard input signal is supplied to shaper Q1; the squared 1 MHz collector signal is amplified by Q2 and supplied to divide-by-4 integrated circuit (IC) Z1. The resultant 250 kHz squarewave output is then supplied through a three-section, 250 kHz bandpass filter to 250 kHz amplifier Q3, a tuned-collector amplifier which restores the sinusoidal shape of the Z1 output. The signal developed across the secondary of tuned transformer T1 is coupled through capacitor C15 to a second 250 kHz collector-tuned amplifier, Q4; the 250 kHz output from the T2 secondary is coupled through capacitor C21 to emitter-follower Q5 and is also developed across the series combination of Output Adjust potentiometer R24 and Level Adjust potentiometer R23. The 250 kHz output from R23 via pin 11 of jack J104 is applied both to MODE switch S102D (rear) contact 9 and to normally open contact 13 of external control relay K102 (figure 7-1); the 250 kHz output from R24 is coupled through capacitor C20 via J104 pin K to MODE switch S102C (rear) pins 9 and 5, as the sub-carrier frequency for USB, LSB, and ISB operation; and the 250 kHz output developed across Carrier Level Adjust potentiometer R27 in the emitter of Q5 is coupled through capacitor C76 via J104 pin 12 to CARR SUPP (DB) switch S103 pin 2 for formulation of the 250 kHz pilot carrier reinsert signal. A switched ground input is supplied to the 250 kHz sub-carrier generator section from the ON position of

the EXCITER switch or from the PTT position of the EXCITER switch when the MIKE input is used. The switched ground is applied via J104 pins L and P, and the AM, USB, LSB and CW positions of the MODE switch and enables 250 kHz amplifiers Q3 and Q4. (Refer to paragraph 4-3 c. for a discussion of MODE switching.)

(2) In the 1.666 MHz channel of Z104, the 1 MHz standard input signal is applied via J104 pin 15 to X5 multiplier Q6 and developed across the 5 MHz tuned collector circuit consisting of transformer T3 and capacitor C30. This resultant signal is then coupled to the first of two subsequent 5 MHz amplifiers Q7 and Q8, and tuned by transformers T4 through T7. The 5 MHz signal developed across the secondary of T7 is applied to shaper Q9 through capacitor C43; the resultant squared signal is then divided by 3 in IC Z2 to produce a 1.666 MHz signal, which is supplied through a three-section 1.666 MHz bandpass filter to 1.666 MHz amplifier Q11. The tuned collector output across transformer T8 is further tuned by coupling transformer T9 and applied to 1.666 MHz tuned output amplifier Q12. The 1.666 MHz output signal from the T9 secondary is applied to converter and ALDC circuit Z103 via J104 pin A for translation to the assigned rf fundamental frequency of 1.417 MHz.

(3) The metering amplifier circuit of Z104 consists of meter amplifier Q13, emitter follower Q14 and the half-wave rectifier and filter output consisting of diode CR4 and capacitor C73. This circuit receives via J104 pin 5 either USB or LSB audio from MODE switch S102C (front) via the USB or LSB positions of METER switch S104A (rear), and provides conversion to a dc level proportional to signal amplitude for display on MONITOR meter M101 via J104 pin 3. (See figure 7-1.)

b. **UPPER AND LOWER SIDEBAND GENERATORS Z105 AND Z109.** (See figures 7-3 and 7-1.) The upper and lower sideband generators are identical in circuit configuration and operation. As shown on figure 7-3, the sideband generator consists of three distinct sections; namely, the audio preamplifier, the SSB modulation circuit, and the voice operated (VOX) audio circuit. A 600-ohm to 500-ohm impedance matching circuit is also included for conversion of an external 600-ohm audio line input to a 500-ohm output when the mike input is not being used for AM, USB, LSB or ISB operation.

(1) The audio preamplifier circuit consists of a cascode-connected microphone input amplifier and isolation emitter follower, followed by two cascaded class A audio amplifier stages and an output emitter follower. Input audio at pin D of J105, in the range of 300 Hz to 7.5 kHz, is coupled to the cascade pair, Q1 and Q2, which present a high input impedance of 47K-ohms to the external microphone. Capacitor C81 introduces degenerative feedback to audio input signals above 7.5 kHz. The audio signal developed across Level Adjust potentiometer R8 is R-C coupled to the first of two cascaded class A amplifiers Q3 and Q4. Bypassed emitter resistors (R13 and R16) in these stages introduce a small

amount of degenerative feedback, thereby limiting distortion and improving the overall audio frequency response of the preamplifier section. The audio signal from output emitter follower Q5 is coupled through C11 via jack J105 pin A to MODE switch S102A (front) (contact 5) for distribution to either the upper or lower sideband generators in USB or LSB operation, or to both of the sideband generators when independent sideband (ISB) operation is desired. (See figure 7-1.)

(2) The SSB modulation circuit receives an audio input signal from the MODE switch; when the MODE switch is set to the USB or LSB positions, audio is channeled to the respective sideband generator audio input and is used to modulate the 250 kHz subcarrier input from carrier generator Z104. In the ISB position of the MODE switch, audio signals are channeled simultaneously to both of the sideband generators to institute independent sideband (ISB) operation.

Input audio signals from MODE switch S102C (front) in the USB, LSB or ISB positions, is coupled through series dropping resistor R94 and capacitor C38 to audio amplifier Q28; output signals at the collector are R-C coupled by C68 and R82 to emitter follower Q6 and the emitter output is coupled to balanced modulator Z1 by C71 to modulate the 250 kHz subcarrier output signal from 250 kHz amplifier Q7 received via J105 pin 15. The balanced modulator produces sum and difference frequency outputs, while the subcarrier and audio frequencies are attenuated. The sum and difference frequency output from Z1 is coupled through capacitor C25 to USB (or LSB, depending upon the sideband generator) amplifier Q8. In upper sideband generator Z105, the Q8 collector circuit consisting of the T2 primary and C28, is tuned to the upper sideband frequency range from 250,300 Hz to 253,000 Hz (microphone input) or 250,300 Hz to 257,500 Hz (AM operation). Conversely, in lower sideband generator Z109, this circuit is tuned to the lower sideband frequency range of 247,000 Hz to 249,700 Hz (microphone input) or 242,500 Hz to 249,700 Hz (AM operation). The sideband output at the secondary of T2 is directly-coupled to tuned sideband amplifier Q11; the sideband output frequency developed across the tuned collector tank circuit is supplied to amplifier Q12 and to the AGC circuit. The crystal filter consisting of Y1 and trimmer capacitor C37, presents a decided notch at 250 kHz, thereby fully suppressing the 250 kHz subcarrier center frequency. Amplifier Q12 is gated by the voice operated (VOX) signal (paragraph 4-3 b. (3)) and thus amplifies the sideband signal; the sideband output from amplifier Q12 is coupled through band-pass filter Z2 to the Darlington output pair, Q17/Q18, which isolate the mode switching network from the sideband generator. The emitter signal from Q18 is then supplied to the mode switching network (paragraph 4-3 c.).

In the AGC circuit, the sideband signal from the secondary of transformer T3 is fed to a Darlington-connected input pair, Q20/Q21, which effectively isolates the sideband circuit from the AGC circuit. The output signal from Q20 is coupled through capacitor C56 and developed across AGC Adjust potentiometer R56, which sets the average amplitude

of the AGC input signal to amplifier Q19, and thus the overall AGC bias. The sideband output signal from Q19 is developed across the tuned collector tank circuit consisting of the T4 primary and capacitor C52. The secondary signal is rectified by diode CR3 and filtered by the R48/C49 combination, thereby producing a dc level proportional to sideband signal amplitude. The AGC level is further amplified by dc amplifier Q16 and is coupled through diode CR2 to the Darlington pair consisting of Q14 and Q13. This pair provides the required AGC drive current for AGC control amplifiers Q9 and Q10. Since each of these transistors forms an effective variable impedance in the emitter circuit of respective sideband amplifiers Q8 and Q11, they effectively regulate amplifier gain, thus maintaining the sideband output signal within nominal limits.

(3) Whenever voice operated (VOX) modulation occurs, either through the external microphone or the 600-ohm audio input line, VOX audio appears at the VOX circuit input via J105 pin 12 from the MODE switching network. This audio signal is first applied to emitter follower Q29 and cascade-connected amplifiers Q22 and Q23, and then supplied to positive rectifier CR6; diode CR5 passes the negative half-cycle to ground. Thus, a positive, pulsating dc level is produced, and is applied to emitter follower Q24; the positive output from Q24 drives the Schmitt Trigger consisting of Q25 and Q26. The Schmitt Trigger is essentially a pulse-shaping circuit, in that it turns on quite rapidly whenever the positive audio level appears at the Q25 input, thereby producing a positive output gate whose duration corresponds to the length of time the audio input is present. The combination of C67 and R70 is a speed-up network which greatly improves the turn-on rise time and turn-off fall time of the output gate in response to the audio intelligence. The positive output gate from Q26 is applied to relay driver Q27, thus causing this stage to turn on and supply PTT-VOX relay K1 with the required ground for pull-in. As a result, with relay K1 energized whenever voice transmissions occur, a ground return through diode CR1 causes gate Q15 to turn on, thereby enabling sideband amplifier Q12 to amplify the upper or lower sideband output signal from Q11. In addition, the output ground from relay K1 is supplied as a PTT enable to TB105-14 and also causes PTT relay K101 to energize and complete an interlock via the TRANS terminals of TB103, terminals 5 and 6 to the external equipment.

c. MODE SWITCHING. (See figures 4-2, 4-3 and 7-1.) Mode switching for the SME-6 is accomplished by MODE switch S102, which selects the desired mode of operation (AM, USB, LSB, ISB, CW, FSK and FAX) by routing audio, subcarrier and certain enables to the proper circuits of the Exciter. Mode switching can be divided into areas of audio, present in the AM, USB, LSB and ISB modes, and the remaining modes of CW, FSK and FAX operation.

(1) In the audio modes (figure 4-2), microphone or 600-ohm line audio inputs from the upper and/or lower sideband generators are coupled to a respective divider network on MODE switch S102A (front). Consider upper sideband (USB) audio.

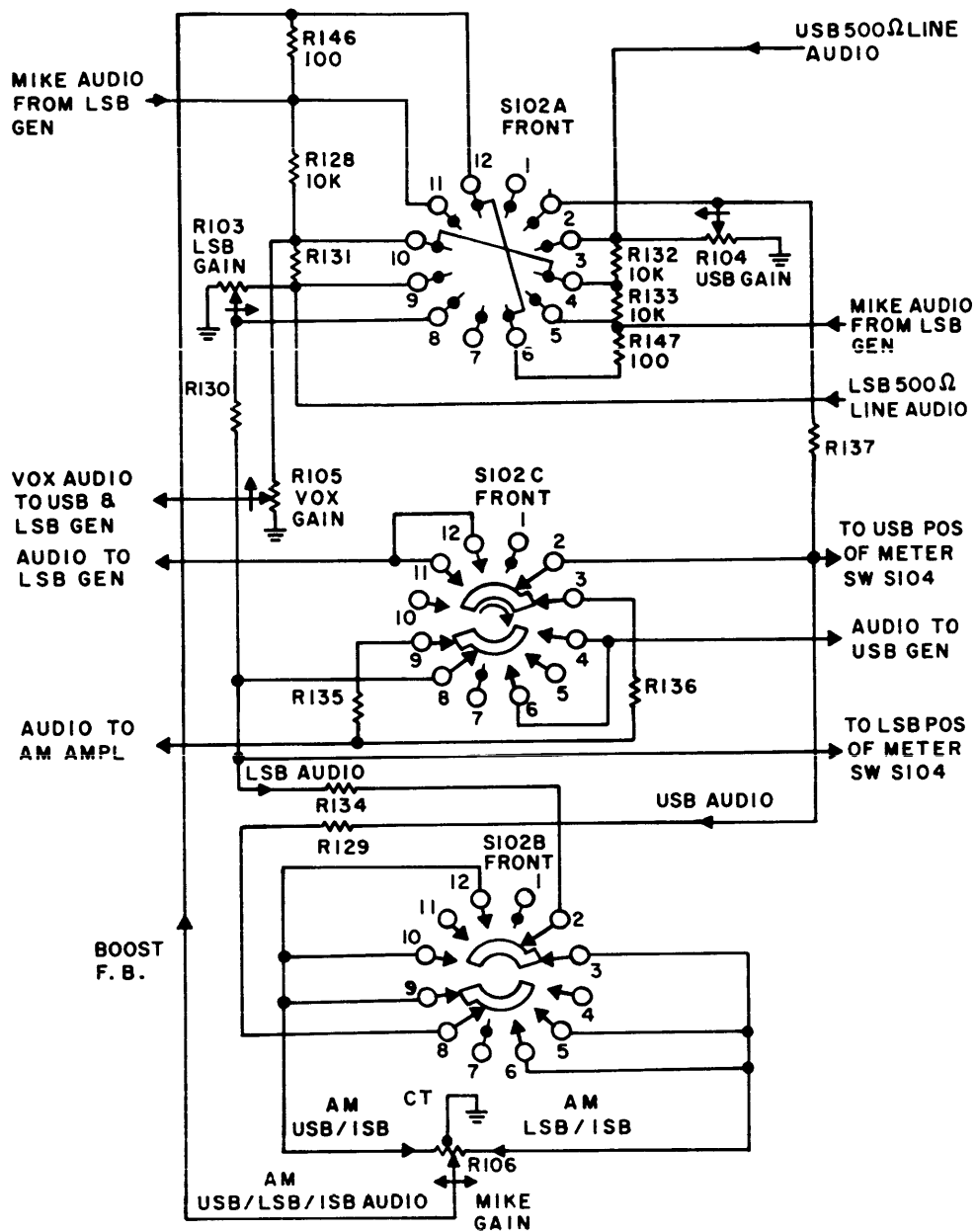

Figure 4-2. Audio Mode Switching, Simplified Schematic Diagram

Microphone audio, from the USB audio preamplifier circuit, J105 pin A, is developed across the divider consisting of resistors R133, R132 and USB GAIN control R104. The audio signal appearing at contact 4 of S102A is routed through contact 10 and developed across VOX GAIN control R103. When the 600-ohm audio input line is used, the USB generator (figure 7-3) supplies a 500-ohm line audio output from J105 pin 1, which is developed across USB GAIN control R104 and is supplied through dropping resistor R132 to contacts 4/10 of S102A. In either case, USB GAIN control R104 sets the amplitude of the USB audio signal and applies it through R137 to the USB position of METER switch S104 and contact 2 of

S102C (front), and through R129 to contact 8 of S102B (front). With the MODE switch in the AM position, the USB audio is coupled through contact 3 of S102C and R136 to J108 pin 15 on the AM amplifier Z108; in the USB position, the audio is coupled through contact 4 of S102C to the upper sideband generator audio input jack J105 pin 13; in the LSB position, LSB audio from LSB GAIN control is coupled through contacts 8/11 of S102C (front) to the lower sideband generator audio input J109 pin 13 and in the ISB position of S102C (front), both USB and LSB audio is sent simultaneously to the respective sideband generator audio input (if audio intelligence is desired on both J105 pin 13 and J109 pin 13 respectively).

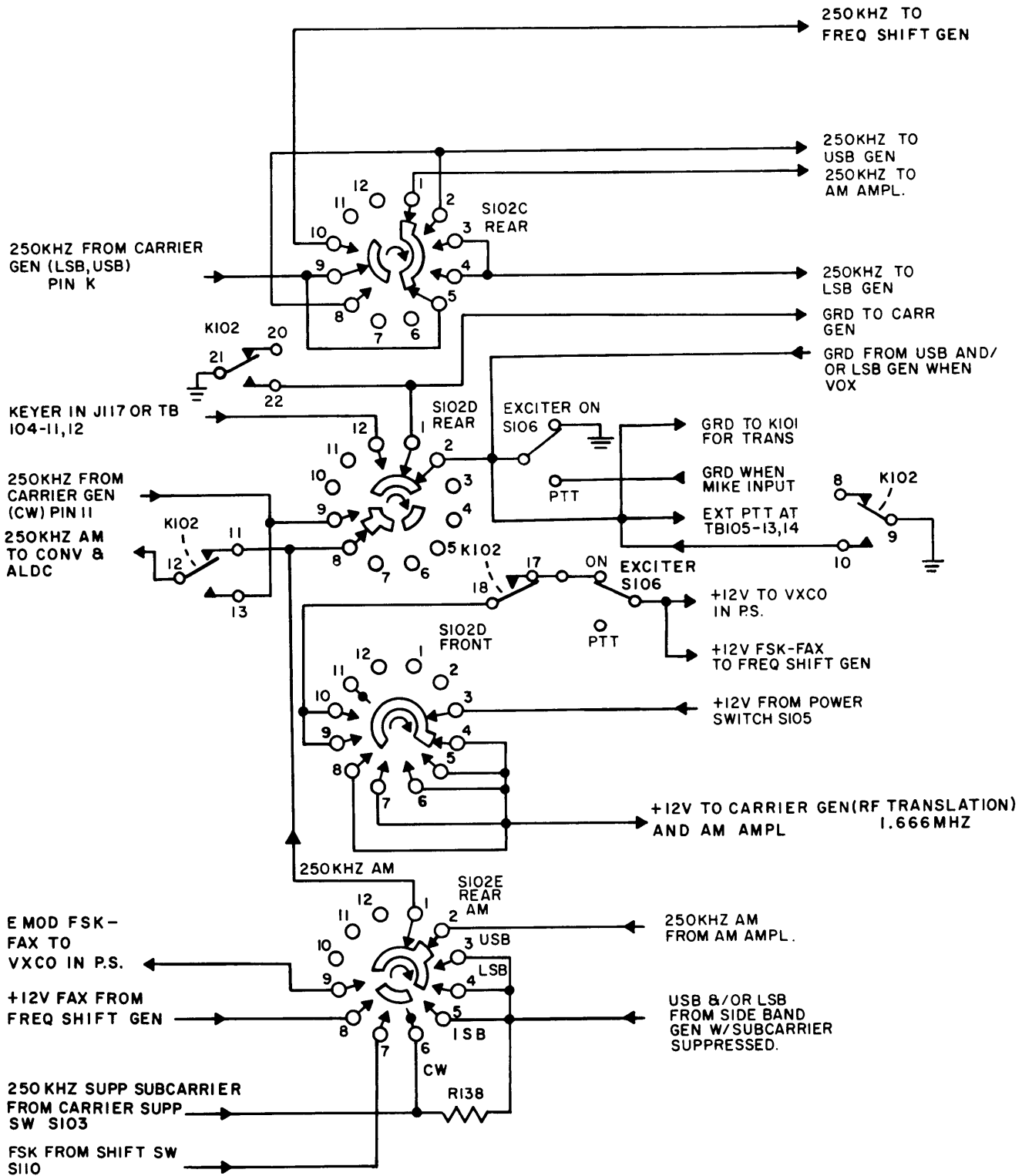

Figure 4-3. CW, FSK, and FAX Mode Switching, Simplified Schematic Diagram

The USB and/or LSB audio developed across VOX GAIN control R105 is sent to the respective VOX audio input of the USB and LSB generators (J105 pin 12 and J109 pin 12 respectively). Upper sideband audio appearing at contact 8 of S102B is coupled to MIKE GAIN control R106 through the AM, USB or ISB positions; lower sideband audio appearing at contact 2 of S102B is coupled through the AM, LSB or ISB positions to the other side of the MIKE GAIN control. Since the centertap of R106 is grounded, the control provides audio injection of AM, USB or LSB to the respective microphone audio input through isolation resistors R146 and R147 on S102A.

(2) The remaining decks of MODE switch S102 (C rear, D front and E rear) perform independent functions such as 250 kHz subcarrier and AM distribution and reinsertion, and CW, FSK and FAX selection. (See figure 4-3.) The 250 kHz subcarrier output from carrier generator Z104 (J105 pin 11) is applied to S102C (rear) at contacts 9 and 5. With the MODE switch in the AM position, the subcarrier is channeled to AM amplifier Z108; in the USB, LSB and ISB positions, the 250 kHz subcarrier is applied to either the respective sideband generator, Z105 or Z109, or to both sideband generators simultaneously. Deck S102D (front) of the MODE switch distributes +12 vdc operating potential to carrier generator Z104 via J104 pins 6, 8 and 14, and AM amplifier Z108 in the AM, USB, LSB, ISB and CW positions via J108 pin 9. (See figure 7-1.) In the FSK and FAX positions, +12 vdc is routed through normally closed contacts 18/17 of external control relay K102 and the ON position of EXCITER switch S106 to frequency shift generator Z107 via J107 pin J and the variable crystal-controlled oscillator (VXCO) J301 pin K, in the power supply assembly. The amplitude-modulated 250 kHz output at J108 pin E of AM amplifier Z108 is supplied to the AM position of S102E (rear) and is coupled through normally closed contacts 11/12 of external control relay K102 to converter and ALDC circuit Z103. In the USB, LSB and ISB positions of S102E, sideband audio intelligence, with a suppressed 250 kHz subcarrier, is supplied from either or both sideband generators to contacts 3, 4 and 5. This SSSC input is added to the 250 kHz subcarrier signal from CARR SUPP switch S103 pin 1 through isolation resistor R138. The amount of subcarrier injection depends on the position of S103 and may consist of no subcarrier injection (0), full injection (FULL), continuously variable injection (VAR), or injection at 6 db or 26 db below sideband amplitude. When subcarrier injection is desired, the resultant USB and/or LSB audio intelligence is accompanied by a 250 kHz pilot carrier and is supplied to converter and ALDC circuit Z103 at J103 pin E.

Frequency Shift Keyer (FSK) and facsimile (FAX) operation is controlled by S102E (rear). For FSK operation, a variable dc current, proportional either to the keyed 250 kHz subcarrier frequency, or to an external teletype input, is applied to contact 7 of S102E from SHIFT switch S110 pin 8. This signal is routed via J301 pin L to the variable crystal-controlled oscillator (VXCO) in the power supply

assembly, thereby causing a shift in frequency, above and below center frequency, which represents the marks and spaces in FSK operation. In FAX operation, a variable dc current from frequency shift generator Z107 (via J107 pin 8) is supplied to S102E at contact 8 and is routed to the VXCO (J301 pin L). CW operation is controlled by S102E (rear), where a 250 kHz subcarrier frequency from the carrier generator J104 pin K is routed through contact 8 to the converter and ALDC circuit, J103 pin E of Z103.

d. CONVERTER AND ALDC, Z103. (See figure 7-6.) The converter and ALDC circuit performs the function of translating a 250 kHz input signal to an rf output carrier in the range of 1.417 MHz. The 250 kHz input can be an AM signal; USB and/or LSB intelligence with or without the 250 kHz subcarrier suppressed; or an interrupted 250 kHz input at an external keyed rate in the CW mode. In addition, in the FSK and FAX modes, a variable crystal-controlled frequency of 1.417 MHz is supplied to the converter circuit for translation, while the 1.666 MHz carrier and 250 kHz inputs are not used.

(1) As discussed previously, when the MODE switch is in the AM, USB, LSB, ISB or CW positions, the 1.666 MHz channel in the carrier generator is enabled and supplies the 1.666 MHz carrier frequency to the converter channel of Z103. This input signal via J104 pin 15 is amplified by tuned-collector input stage Q1 and applied to the balanced modulator consisting of the transformer T1 secondary, Balance Adjust potentiometer R6 and diodes CR1 and CR2. In the AM position of MODE switch S102, the 250 kHz input at pin L of J104 consists simply of a 250 kHz subcarrier, amplitude-modulated by audio intelligence in the 300 Hz to 7500 Hz range. When the AM signal is mixed with the 1.666 MHz input, the balanced modulator produces the sum, difference and two original frequencies; the 250 kHz subcarrier is attenuated and the combination of tuned transformer T2 and capacitor C15 traps the 1.666 MHz signal. As a result, an amplitude-modulated 1.417 MHz rf signal results and is amplified by Q2. The collector output of Q2 is coupled through 1.417 MHz filter Z1 and amplified by two subsequent 1.417 MHz amplifiers Q3 and Q4 tuned by respective transformers T3 and T4. The 1.417 MHz AM tuned collector output of Q4 (at pin A of J103) is developed across RF OUTPUT control R102 (figure 7-1) and is applied to the inputs of five parallel-connected, dual-channel rf amplifiers, Z101, Z102 and Z111 through Z113, via pin N of the respective module plug connector.

(2) In the USB, LSB and ISB positions of MODE switch S102, the 250 kHz input to the converter consists of upper and/or lower sideband audio intelligence in the 300 to 3300 Hz range with the 250 kHz carrier suppressed or unsuppressed, according to the position of CARR SUPP (DB) switch S103. These signals are obtained from contacts 3, 4 and 5 of S102E (rear). Since the 1.666 MHz rf carrier input is also present at these modes, the balanced modulator produces upper and/or lower sideband signals with a center frequency of 1.417 MHz. If the 250 kHz subcarrier is suppressed, so also is the

1. 417 MHz rf carrier; the difference frequency between 1.666 MHz and 250 kHz. The upper and/or lower sideband signals are amplified in the same manner as the AM signal, and are sent to the five rf amplifiers.

(3) In the CW position of MODE switch S102, the 250 kHz input is not modulated by audio intelligence, but is interrupted at a rate determined by a keyer input at KEY jack J117 or at terminals 11 and 12 of TB104 on the rear panel of the Exciter. This results in a keyed difference frequency of 1.417 MHz in the balanced modulator. The CW rf is then amplified as before and developed across RF OUTPUT control R102.

(4) In the FSK and FAX modes of operation, the 1.4166 MHz variable crystal-controlled oscillator (VXCO) is enabled in the power supply assembly, and its frequency is varied by the dc current produced in the FSK and FAX circuits of frequency shift generator Z107. Since both the 250 kHz and 1.666 MHz inputs are inhibited in these modes, the 1.4166 MHz FSK-FAX input is coupled via jack J103 pin 8 and capacitor C4 to the input of 1.417 MHz amplifier Q2, thus bypassing 1.666 MHz amplifier Q1 and the balanced modulator circuit.

(5) The Automatic Load and Drive Control (ALDC) circuit of Z103 receives a dc bias at jack J103 pin E from the external transmitter whenever the transmitted envelope crest exceeds a preset threshold. This bias effectively reduces the rf output from the converter by cutting down the net input signal to 1.417 MHz amplifier Q2. The ALDC bias is applied to a cascode-connected input pair consisting of Q5 and Q6. The dc output from Q6 is applied to ALDC output emitter follower Q7; the ALDC output is then supplied as bias to the base circuit of Q2 through resistor R11.

e. AM AMPLIFIER Z108. (See figure 7-4.) The AM amplifier performs the function of amplitude-modulating the 250 kHz subcarrier signal with audio intelligence in the 300 Hz to 7500 Hz range, and supplies it to the converter and ALDC circuit, Z103, when the MODE switch is positioned at AM.

With the MODE switch in the AM position, the 250 kHz subcarrier is applied to AM amplifier Z108 via jack J108 pin L from S102C (rear) contacts 1, 5 and 9; USB and/or LSB audio is supplied from the AM position of S102C (front) to the AM amplifier via jack J108 pin 15. The audio input is coupled through C1 to a conventional audio amplifier, Q1, whose collector output is fed to emitter follower Q2; this latter stage provides isolation between the modulator stage Q3 and the input audio amplifier. The audio output from Q2 is coupled through capacitor C9 to the emitter of modulator Q3. The 250 kHz subcarrier frequency is coupled to the base of modulator Q3 through capacitor C5, resistor R7 and capacitor C7. Since the emitter of Q3 is modulated with the audio signal, the resultant collector signal across the T1 primary and C10 consists of a 250 kHz subcarrier whose amplitude fluctuates at the audio signal rate. The 250 kHz amplitude-modulated

signal at the T1 secondary is developed across AM Level Adjust R15, and coupled through C12 to the AM position of MODE switch S102E (rear) via pin E of jack J108. With S102 in the AM position, the 250 kHz AM signal is then routed to the 250 kHz input of converter and ALDC circuit Z103 (pin L of jack J103).

f. FREQUENCY SHIFT GENERATOR Z107. (See figures 4-4 and 7-5.) The frequency shift generator is operational in the frequency shift keyer (FSK) and facsimile (FAX) modes of operation, and consists of three distinct sections; namely, the 1.4166 MHz VXCO buffer-amplifier, the FSK keyer and modulator, and the FAX circuit.

(1) Both FSK and FAX operation is initiated when MODE switch S102D (front) is set to either the FSK or FAX position as previously indicated in the discussion of MODE switching. In either of these positions, S102D supplies a +12 vdc enable to both the 1.4166 MHz crystal voltage controlled oscillator Z302 in the power supply assembly, and to the buffer-amplifier circuit in frequency-shift generator Z107. With MODE switch S102 in the FSK position, S102C (rear) (through contacts 9 and 10) routes the 250 kHz subcarrier frequency from carrier generator Z104 to the frequency shift generator keyer circuit (via pin 4 of jack J107) consisting of coupling transformers T1/T2 and keyer diodes CR1/CR2. The keyer circuit is, in effect, a modulator, in that the 250 kHz input is interrupted by a dc current representing marks and spaces from an externally connected dry-contact keyer or teletype at terminals 15 and 16 of TB105. (See figure 4-4.) The keyer input pins F and E of jack J107 is connected to the modulator through FS LOOP switch S111 which is set to the 100V or 50V positions when dry contact keying is used, and to the 20mA or 60mA positions to match the dc battery loop when a teletype keyed input is used. The external keying rate is 200 WPM and 75 bauds. By keying the 250 kHz subcarrier, a frequency shift above and below center frequency is obtained, corresponding to the marks and spaces of the teletype input. This signal is coupled through T2 to the full-wave bridge rectifier consisting of diodes CR3 through CR6; the resultant varying dc signal is then applied to a series of three dc amplifiers, Q3 through Q5, and an output emitter follower, Q6. (See figure 7-5.) Amplifier Q4 is inserted in the circuit when dc SENSE switch S109 is in the positive (+) position; otherwise, in the negative (-) position, Q4 is bypassed. The variable dc output is developed across FSK Balance potentiometer R22 and applied to FSK Shift potentiometer R23; the dc output is coupled by pin 5 of jack J107 to SHIFT switch S110. FSK Center Frequency Adjust potentiometer R25 sets the average level about which the dc signal varies (available at pin 7 of jack J107), and thus the center frequency of the VXCO in the power assembly. DC regulator Q8 provides a regulated 24 vdc to the dc amplifier circuit from the +24 vdc supply input line; regulator Q7 supplies a regulated +12 vdc to SHIFT switch S110 and R23 from the +12 vdc MODE switch input. SHIFT switch S110 effectively sets the amplitude of the dc signal varying about the average dc level as set by R25. By changing the maximum amplitude, the shift in VXCO output

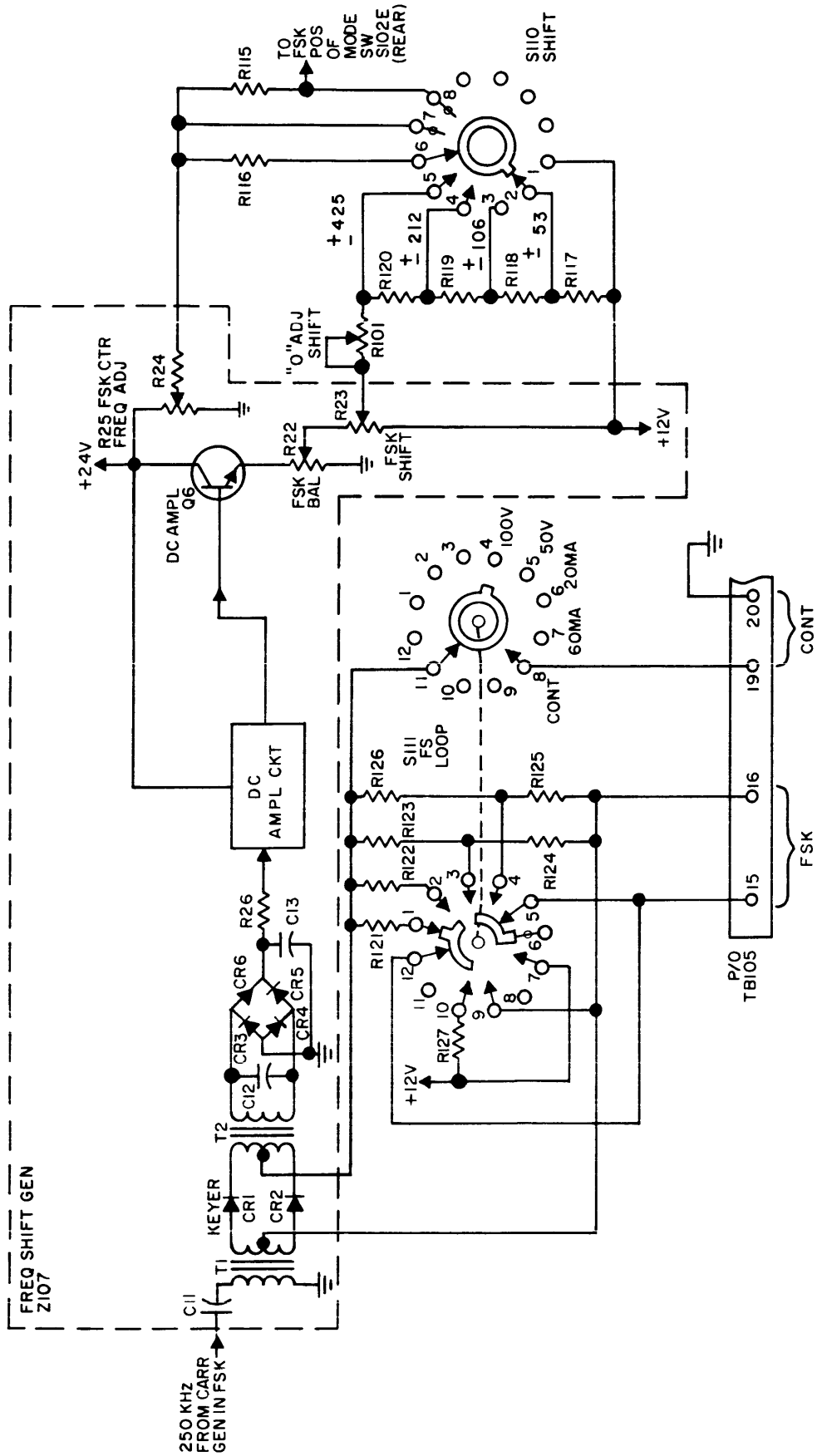

Figure 4-4. Frequency Shift Keyer Circuit, Simplified Schematic Diagram

frequency is correspondingly changed to provide the desired shift above and below center frequency. The varying dc output from the SHIFT switch is coupled through the FSK position of MODE switch S102E (contacts 8 and 9) and sent to the 1.4166 MHz VXCO in the power supply assembly, via J301 pin L input.

(2) With +12 vdc applied to 1.4166 MHz oscillator Z302, and with the variable dc input present, representing keyer frequency shift, the frequency of Z302 varies about the 1.4166 MHz center frequency by an amount dictated by SHIFT switch S110. This shifted frequency is applied to the buffer-amplifier section of frequency shift generator Z107. The input signal, pin M of jack J107, is amplified in buffer Q1, and applied to limiter Z1 which maintains amplitude within acceptable limits without destroying the frequency shift characteristics. The limiter output is applied to emitter follower Q2 and then through 1.4166 MHz Level Adjust potentiometer R16 via pin H of jack J107 to converter and ALDC circuit Z103.

(3) In FAX operation, an externally applied facsimile input at terminals 17 and 18 is applied to dc regulator Q9 at pin 12 of J107. The facsimile input is a variable dc voltage and causes a shift in output voltage across FAX Balance potentiometer R28. This varying voltage is developed across FAX Shift potentiometer R29 and is sent via pin 8 of J102 to the FAX position of MODE switch S102E (rear) contact 8. When FAX is selected, this dc signal then modulates the VXCO in the power supply assembly in the same manner as FSK operation.

g. RF AMPLIFIERS Z101, Z102 AND Z111 THROUGH Z113. (See figure 7-7.) Each of the five rf amplifiers are similar in circuit configuration and operation; the only difference is the frequency of the internal local oscillators used for translation to the assigned rf output frequency. Each rf amplifier contains two channels, one even and one odd; the frequency of the oscillator depends on desired rf output frequency. Operating voltage for each channel is controlled by the front panel CHANNEL SELECTOR switch; depending upon selection of even or odd channel output frequency, +24 vdc to the circuits is routed to the respective channel, while the alternate channel is disabled.

(1) Each of the five rf amplifiers receives a 1.4166 MHz input signal containing AM, USB, LSB, ISB, CW, FSK or FAX information at pin N of the respective input jack. This input signal is amplified by Q7 and coupled to balanced mixer Z3. If the selected channel is odd (channels 1, 3, 5, 7 or 9), +24 vdc is applied to rf oscillator Z1 and the odd channel circuit consisting of Q1 through Q4; if the selected channel is even (channels 2, 4, 6, 8 or 10), +24 vdc is applied to rf oscillator Z2 and the even channel circuit consisting of Q8 through Q11. If oscillator Z1 is enabled, the rf output is coupled through summing resistor R3 to the input of amplifier Q5; if oscillator Z2 is enabled, the rf output is coupled through summing resistor R22 to the Q5 input. Thus, the selected rf output from the oscillator

in question is amplified by Q5 and coupled to emitter follower Q6; the output from Q6 is then applied to balanced mixer Z3. Operating voltage for the Q5/Q6 combination is present regardless of the selected channel, and is routed to this circuit by either steering diode CR2 or CR5.

(2) Balanced mixer Z3 produces the sum and difference frequency outputs while attenuating the two original frequencies, and couples them through respective isolation resistors R40 and R41 to the odd and even channel amplifier circuits. Since only one channel is enabled, the resultant rf signal is amplified and filtered and coupled through respective steering diodes CR3 or CR6, and capacitor C51 to the rf amplifier output. Networks Z4 through Z7 for the odd channel and Z8 through Z11 for the even channel are combination bandpass/trap filters for the particular odd or even frequency band selected as the rf carrier. These filters reject all but the difference frequency output of balanced mixer Z3, thereby translating the 1.4166 MHz input to a desired odd or even rf output carrier. Thus, with five rf amplifiers, using different internal oscillators, operating above the incoming signal, five odd or five even rf carrier bands are available depending upon the position of CHANNEL SELECTOR switch S101. (See figure 7-1.) It should be noted that the frequency of each internal oscillator will depend upon customer requirements as to the available odd and even rf output bands from the SME-6. Each of the five rf amplifier outputs are connected in parallel, with the particular enabled output frequency being supplied via pin A to rf output circuit Z115. Table 4-1 presents a listing of available odd and even output frequency bands.

TABLE 4-1. RF OUTPUT FREQUENCY BANDS

Odd Channel Frequency	Even Channel Frequency
1.6—2.0 MHz	2.0—3.0 MHz
3.0—4.0 MHz	4.0—6.0 MHz
6.0—8.0 MHz	8.0—12.0 MHz
22.0—16.0 MHz	16.0—24.0 MHz
24.0—30 MHz	

h. RF OUTPUT Z115 AND METERING CIRCUIT. (See figure 7-8.) RF output Z115 consists of three rf stages, Q1 through Q3. The selected input frequency range from the respective amplifier is applied through pin B of jack J115 to cascode amplifier Q3 through a dual LC filter consisting of L7, L24, C20 and C39. Potentiometer R1 establishes the operating bias of the input stage, while RF OUTPUT control R103 sets the desired input signal amplitude. The collector output of Q3 is coupled through C9 and isolation transformer T1 to the first of two cascade-connected rf amplifiers Q2/Q1. The output signal from Q1 is coupled through C14 and applied to RF OUTPUT jack J124 via pin S of jack J115, and to the

rf metering and ALDC circuits. The signal to the metering circuit is coupled through isolation resistor R17 and capacitor C37 to diode CR2 which rectifies the negative half-cycle; the positive half-cycle is then filtered to produce a dc level proportional to the amplitude of the rf output. This level which is available at pin 3 of jack J104 is supplied to MONITOR meter M101 when METER switch S104 is in the RF position.

In the metering circuit (figure 7-1), +30 vdc and +24 vdc (pins E and P of jack J301) from the power supply assembly is coupled to METER switch S104 (front) and through respective dropping resistors R144 or R113/R114 to S104 (front) (contacts 1 and 2/3 respectively) and to rf output circuit Z115 at pin J and pins 9/11 respectively. Therefore, meter M101 is effectively placed in series with the collectors of each rf amplifier and the B+ supply voltage, thereby monitoring respective collector current of each amplifier when METER switch S104 is set to the Q1 (350 ma), Q2 (130 ma) or Q3 (65 ma) position. Potentiometer R142 provides a means of calibrating meter M101. In all other positions (USB, LSB, CARR and RF) of switch S104, one side of meter M101 is returned to ground through S104 (front) (via contacts 4 through 7), while S104B connects the other side of the meter to the respective USB, LSB, CARR or RF output. In these positions, the MONITOR displays relative amplitude of the output signals.

i. POWER SUPPLY ASSEMBLY. (See figures 7-9 through 7-11.) Three subassemblies are incorporated into the power supply: namely, rectifier and filter capacitor board (A) Z304, regulator Z303, and heat sink Z305. (See figure 7-9.) Also included is power transformer T301, 1 MHz standard oscillator Z301, and the 1.4166 MHz ovenized oscillator Z302 (FSK and FAX operation). Input power of either 115 or 230 vac is applied to power transformer T301 via power input jack J116, line fuses F101 and F102, and pins C and A of jack J301. For 115-volt operation, the primaries of T301 are connected in parallel and line fuses of 1.0-ampere value are used; for 230-volt operation, the primaries of T301 are connected in series and fuse value is 0.5 ampere. The secondary output voltage, approximately 60 vac, is applied via pins C and B of jack J304 to the full-wave bridge rectifier CR1 on Z304 (figure 7-10). The

rectified output voltage of 50 vdc is filtered by C4 and applied to regulator Z303 via pin A of J304. The center tap voltage from T301, approximately 30 vac, is filtered by capacitor C3 and also applied as +20 volts to regulator Z303 via pin E of J304 and pin E of J303.

(1) The +40 volt input to regulator Z303 (figure 7-11) is developed across the combination of voltage reference diode CR5 and 24V Current Adjust potentiometer R12, thus providing a stable positive reference input to over-current amplifier Q6. As a result, Q6 conducts by an amount proportional to the setting of R12, and causes regulator drivers Q2 and Q3 to conduct, which, in turn, cause respective series regulators Q302 and Q303 to conduct on heat sink Z305. The supply collector current drawn by regulator Q302 is sensed by the R15, R19 and CR2 network in the emitter circuit of over-current amplifier Q6, thereby establishing a current reference in conjunction with the bias applied to the base via R12. Series regulator Q302 furnishes a +30 vdc output at pin E of jack J301 while regulator Q303 supplies +24 vdc at pin P of jack J301.

(2) Fluctuations in the +24 vdc output of Q303 is applied to a resistive divider consisting of R6, +24V Adjust potentiometer R18 and R16; R18 applies this positive voltage to dc amplifier Q7. Since the emitter of Q7 is maintained at a constant +15 vdc potential by zener diode CR7, variations in the output voltage, when compared with this stable reference, cause Q7 to provide more or less drive current to regulator drivers Q2 and Q3. As a result, the +24 vdc and +30 vdc outputs are maintained at relatively nominal values. The +12 vdc regulator, consisting of Q1, Q4, Q5 and Q301, is similar in operation to the +24 vdc/+30 vdc regulators. (This regulated +12 vdc is an output at pin H of jack J301.)

(3) The +30 vdc output from the power supply assembly (figure 7-9) is applied to sideband generators Z105 (pin 10 of J105) and Z109 (pin 10 of J109), and to METER switch S104 (front) (contact 1); the +24 vdc and +12 vdc outputs are applied to POWER-STANDBY switch S105. The +24 vdc output is also routed directly to rf amplifiers Z101, Z102 and Z111 through Z113 (pin S of the respective jack). (See figure 7-1.)

SECTION 5
MAINTENANCE

5-1. PREVENTIVE MAINTENANCE

The following paragraphs describe procedures to inspect, check and align the components of the SME-6. In general, preventive maintenance provides a basis for recognizing future probable causes of equipment malfunction in the early stages of deterioration. Many such causes are apparent to the senses of sight, touch and smell. Therefore, by adhering to a stringent program of preventive maintenance, involving periodic inspection and checks, the most probable causes of equipment malfunction can be avoided, thereby minimizing equipment downtime and the possibility of compromising important schedules. Paragraph 5-3 b. presents a listing of test equipment required for SME-6 maintenance.

a. INSPECTION AND TEST. The following paragraphs describe equipment inspection and power supply checks to be performed on a weekly and daily basis, respectively. Daily checks should be performed at the beginning of each operating day.

(1) General Inspection. A most important and least expensive tool in the preventive maintenance program is the sense of sight; a thorough visual inspection of an assembly or component for tell-tale signs of deterioration prior to failure can save hours of test and troubleshooting time after a complete breakdown. Table 5-1 presents a weekly inspection checklist for the SME-6.

TABLE 5-1. WEEKLY INSPECTION ROUTINE

Assembly or Subassembly	Check
Line Power Cord	Check three-wire line power cord for cracks, nicks or fraying
Main Chassis Assemblies	<ol style="list-style-type: none"> 1. Check underside of chassis for dirt and dust 2. Check all inter-connector wiring for nicks, cracks or fraying 3. Check all printed circuit boards for cracks; check components for looseness and evidence of deterioration from possible overheating 4. Check printed circuit board jacks for tightness against chassis

TABLE 5-1. WEEKLY INSPECTION ROUTINE (cont)

Assembly or Subassembly	Check
Main Chassis Assemblies (cont)	5. Check ground connections for security
Front and Rear Panels	<ol style="list-style-type: none"> 1. Check panel for general cleanliness 2. Check all control knobs for smooth action from limit-to-limit. Check all switches for positive action 3. Check MONITOR meter face for cracks, scratches, etc. 4. Check indicator faces for cracks 5. Remove line fuses and check for proper 1-ampere or 0.5-ampere value and condition (0.5-ampere with 230 vac line) 6. Check all input/output jacks for security against panel

(2) Power Supply Checks. Perform power supply checks as follows:

(a) Check that line power cord is not plugged into 115 or 230 vac source.

(b) Unplug power supply regulator board Z303 from its receptacle at the rear center of the chassis; insert the small extender board in the vacated receptacle and mount the regulator board on the extender board.

(c) Check that POWER switch on front panel is in STANDBY position and connect line power cord to 115 or 230 vac source as applicable.

(d) Using an HP410B VTVM, or equivalent, check dc voltage at pin F of Z303; voltage should be +12 vdc $\pm 5\%$.

(e) Check voltage at pin 4 of Z303; voltage should be +24 vdc $\pm 5\%$.

(f) Check voltage at pin 3 of Z303; voltage should be +30 vdc $\pm 5\%$.

(g) Remove line cord from power source, and replace regulator board into mating jack J303 after removing extender board.

(3) Functional Test. Perform the check-out procedure for the SME-6 as outlined in Section 2, paragraph 2-5, on a weekly basis, after a check has been made of the power supplies.

b. CLEANING INSTRUCTIONS. In general, the SME-6 should be cleaned once a week, using a soft camel's hair brush, forced air pressure of not more than 20 psi and a suitable cleaning agent such as trichlorethylene or methylchloroform.

WARNING

When using toxic solvents, make certain that adequate ventilation is provided; prolonged or repeated breathing of the vapor shall be avoided. Avoid prolonged or repeated contact with the skin. Flammable solvents shall not be used on energized equipment or near other equipment from which a spark may be received.

CAUTION

Trichlorethylene contains a paint removing solvent; avoid contact with painted surfaces.

Remove dirt or grease from wiring and chassis surfaces using cleaning solvent; dry with compressed air. Remove dust from printed circuit

boards using a soft camel's hair brush. Blow out accumulated dust from inaccessible areas of chassis using forced air.

5-2. TROUBLESHOOTING

The circuits of the SME-6 are contained on 14 PC boards accessible from the top of the chassis. The card Zxxx numbers are the circuit reference designation prefix. Numbers prefixed with an "A" are the PC assembly part numbers by which they are identified and ordered. The "Z" prefix number is silkscreened both on the card and on the chassis adjacent to the PC board receptacle together with the Zxxx designation. Some PC boards in the SME-6 and in other TMC equipment, although they are assigned different "Z" designations, have the same assembly "A" prefix and are thus identical and interchangeable. These PC boards have similar keying at their plug ends and mating receptacles. The power supply assembly heat sink is mounted against the rear wall of the chassis; the smaller power supply boards are mounted forward of the heat sink and are removeable.

In general, a malfunction in the SME-6 will usually manifest itself by lack of, or improper, readings on the MONITOR meter, and can be quickly localized to a particular printed circuit board by the logical process of elimination. If a second SME-6 is obtainable, or a set of spare PC boards is available, troubleshooting can be facilitated by the board substitution method. In some instances, a particular board may require alignment or adjustment as outlined in paragraph 5-3. Table 5-2 presents a troubleshooting chart for the SME-6; figures 5-1 and 5-2 show respective top and bottom views of the equipment.

TABLE 5-2. TROUBLESHOOTING CHART

Step	Trouble	Probable Cause	Remedy
1	No rf output on any selected rf output channel at any setting of MODE switch except FSK and FAX.	Check that POWER indicator is illuminated with POWER switch ON.	If lamp is not illuminated, check power supply voltages as outlined in paragraph 5-1 a.(2). If lamp is illuminated, proceed to step 2.
2		Check for normal display on MONITOR with METER switch in Q1, Q2 and Q3 position.	If all readings are normal, proceed to step 3. If any reading is abnormal, replace Q1, Q2 or Q3 on rf output Z115 as indicated by meter reading.
3		Check for 1 MHz output at 1 MHz MON jack on rear of chassis.	If 1 MHz is present, proceed to step 4. If 1 MHz is not present, check for 1 MHz output at J302 on power supply assembly. If not present, replace 1 MHz standard Z301.
4		Check for 1.666 MHz output from Z104.	If present, proceed to step 5. If not present, make certain MODE switch is in any position but FSK and FAX, and troubleshoot 1.666 MHz section of Z104.

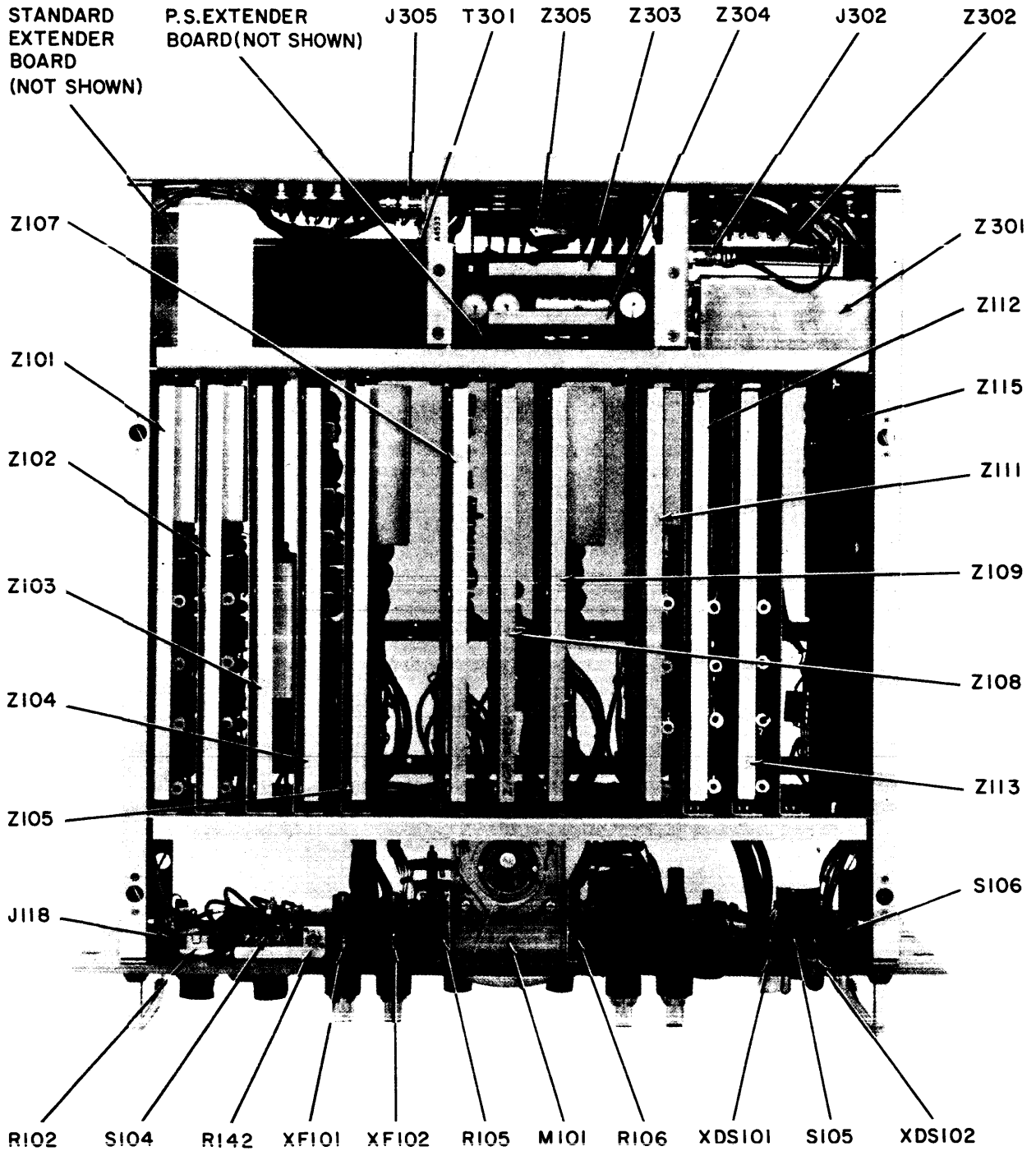

Figure 5-1. SME-6, Top View, Location of Major Components

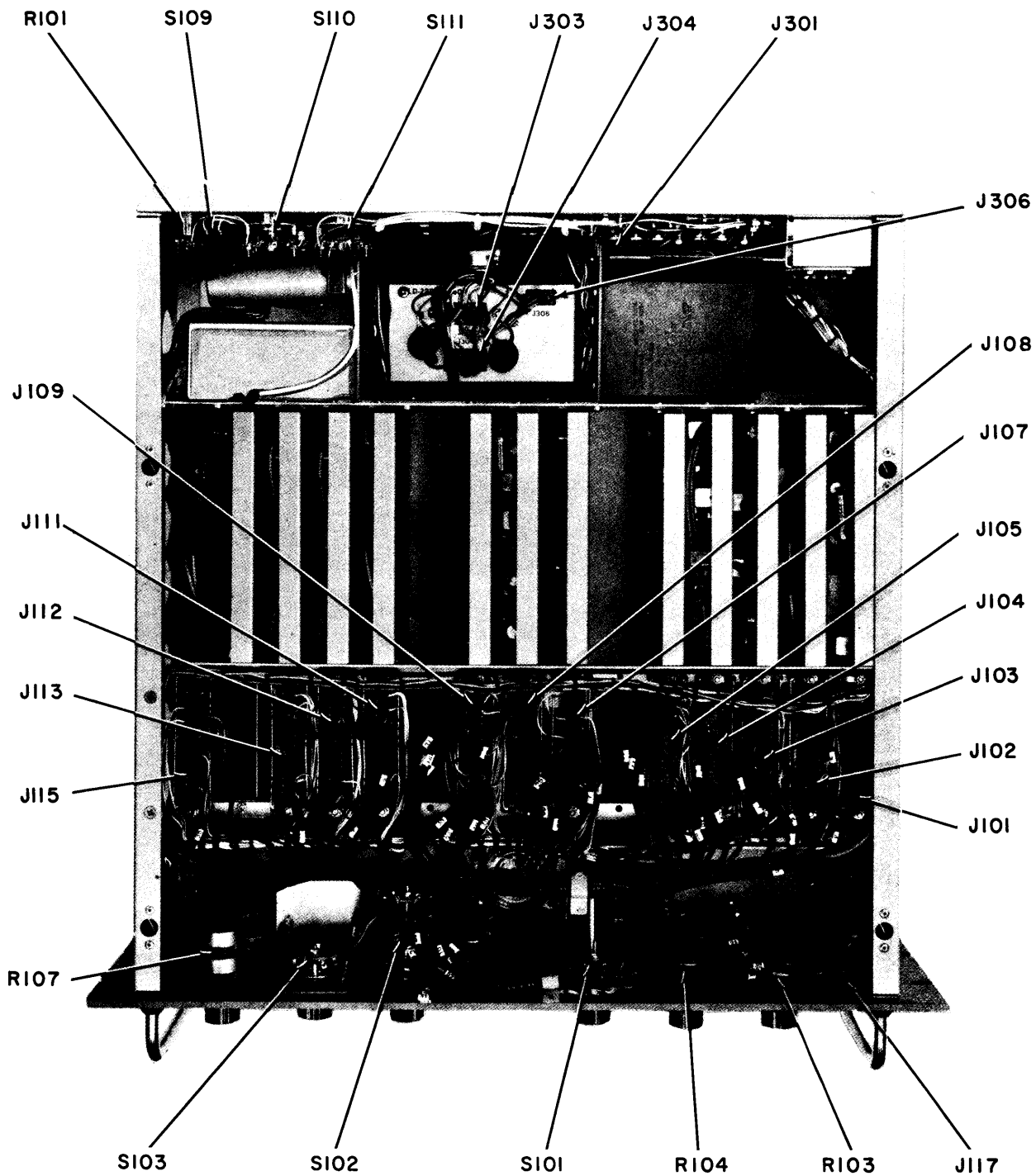

Figure 5-2. SME-6, Bottom View, Location of Major Components

TABLE 5-2. TROUBLESHOOTING CHART (Cont)

Step	Trouble	Probable Cause	Remedy
5	No FSK operation.	Check for 1.4166 MHz output from Z103.	If not present, check for 250 kHz input to Z103. If not present, ground pins P/L of carrier generator and troubleshoot 250 kHz section of Z104. If present, troubleshoot converter section of Z103.
6		1.4166 MHz oscillator Z302 or frequency shift generator Z107.	Check for +12 vdc at pin K of J301 on power supply assembly. If present, check for varying 1.4166 MHz output at J305. If 1.4166 MHz output is present without frequency shift, proceed to step 7. If 1.4166 MHz is not present, replace oscillator Z302.
7		Check for varying 1.4166 MHz output at pin H of Z107.	If not present, check for varying 1.4166 MHz at pin M of Z107. If not present, proceed to step 8. If present, troubleshoot 1.4166 MHz amplifier on Z107.
8	No FAX operation.	Check for varying dc level at pin L of J301.	If present, replace Z302 in power supply assembly. If not present, check modulator, rectifier and dc amplifier circuits in Z107.
9		Same as for FSK operation, except check for varying dc output at pin 8 of Z107 and troubleshoot DC regulator circuit if not present.	
10	No audio in AM mode only.	AM amplifier Z108.	Troubleshoot AM amplifier Z108.
11	No SSB operation.	If normal operation is evident in either USB or LSB modes, trouble is in sideband generator.	Troubleshoot defective sideband generator.

5-3. ALIGNMENT

a. GENERAL. The following paragraphs present alignment procedures required to maintain the Exciter in a satisfactory operating condition.

b. EQUIPMENT REQUIRED. The following equipment is required to completely align the Exciter:

Signal Generator H.P. Model 606A

Scope Tektronix Model 545, or equivalent

Spectrum Analyzer Lavoie Laboratories Inc., Model LA-40A, or equivalent

Audio Generator H.P. 200CD, or equivalent

0-10V, DC Power Supply

Telonic TD-950 Attenuator, or equivalent

Millivolt Meter, Millivac MV-28B, or equivalent

VTVM Hewlett-Packard Model 410B

Voltmeter Simpson 260A

VTVM, Ballantine Model 314, or equivalent

c. **POWER SUPPLY ALIGNMENT.** (See figure 5-3.) Perform the power supply alignment procedure as follows:

- (1) With ac line cord removed; all cards disconnected from the unit; and STANDBY-ON switch to ON, measure resistance from J111-S to ground (1.5K-ohms minimum).
- (2) Measure resistance from J103-14 to ground (200 ohms minimum).
- (3) Turn STANDBY-ON switch to STANDBY and insert Z303 and Z304 into unit.

NOTE

Before inserting Z303, turn potentiometers R3 and R12 fully clockwise.

- (4) Check for any visible shorts.
- (5) Plug in ac line cord. The STANDBY lamp should illuminate.
- (6) Turn power switch to ON position. The red POWER lamp should illuminate.
- (7) Measure dc voltage at J304-6; it should be approximately 45 volts.
- (8) Allow fifteen (15) minutes warm-up.

NOTE

In test procedure, all pin numbers refer to their respective connectors.

- (9) Using Simpson 260-A, measure dc voltage level at J304-A. It should be approximately +40 volts.
- (10) Measure dc voltage level at pin E. It should be approximately +10 volts.
- (11) Measure dc voltage level at J303-E. It should be approximately +20 volts.
- (12) Measure dc voltage level at J303-A. It should be approximately +40 volts.
- (13) Measure dc voltage at J303-F. Adjust potentiometer R8 for exactly 12.0 volts. Set meter to 10 ampere scale and adjust potentiometer R3 for 1.6 amperes. This adjustment sets short circuit current.
- (14) Connect scope to J303-F. Maximum ac ripple should be 5mv.
- (15) Measure dc voltage at J303-4. Adjust potentiometer R18 for exactly 24.0 volts. Set meter to 10 ampere scale. Adjust potentiometer R12 for 1.8 amperes. Connect scope to J303-4. Maximum ac ripple should be 2mv.
- (16) Measure dc voltage at J303-3. Voltage should be 30 volts \pm 1.0 volt.

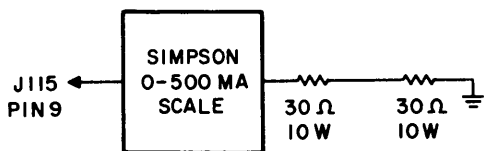

Figure 5-3. Power Supply, Test Setup

(17) Turn power switch to STANDBY position and METER switch to Q1 position. Adjust Meter Adjust potentiometer R142 (located at rear of METER switch) for equal readings on front panel meter and Simpson Model 260, as shown in test setup of figure 5-3.

d. **CARRIER GENERATOR Z104.** Align carrier generator Z104 as follows:

- (1) Connect oscilloscope between J104-15 and ground. The 1 MHz reference frequency input shall be approximately 2.4 volts peak-to-peak.
- (2) Connect carrier generator Z104 into an extender card.
- (3) Connect oscilloscope probe to TP10. Adjust transformers T3 through T7 for maximum 5 MHz signal (level of approximately 0.7 volt peak-to-peak).
- (4) Connect oscilloscope probe to Z2 pin 9. Output shall be a 1.666 MHz squarewave, approximately 4 volts peak-to-peak.
- (5) Connect oscilloscope probe to base of transistor Q11. Output shall be a sinewave approximately 0.14 volt peak-to-peak.
- (6) Connect oscilloscope probe to TP13. Adjust transformers T8, T9, and T10 for maximum 1.666 MHz signal (level of approximately 0.8 volt peak-to-peak).
- (7) Position EXCITER switch to ON.
- (8) Connect oscilloscope probe to Z1 pin 9. Output shall be a 250 kHz squarewave, approximately 4 volts peak-to-peak.
- (9) Connect oscilloscope probe to base of transistor Q3. Output shall be a sinewave approximately 0.4 volt peak-to-peak.
- (10) Connect oscilloscope probe to TP2. Adjust transformers T1 and T2 for maximum 250 kHz signal (level of approximately 2.0 volts peak-to-peak).
- (11) Connect Millivolt meter to J104-11 and adjust potentiometer R23 for 6.3 mv rms.
- (12) Verify that Exciter MODE switch is in USB or LSB position.
- (13) Connect meter to J104-K and adjust potentiometer R24 for 0.61 volt rms.
- (14) Connect meter to J104-12 and adjust potentiometer R27 for 120 mv rms.
- (15) Remove extender cord and reinsert carrier generator Z104 into Exciter.
- (16) Connect oscilloscope probe to J104-K and check for 1 volt peak-to-peak signal with MODE switch in AM, USB, LSB, ISB, FSK and FAX position. Check for 0-volt in CW position.

e. **CONVERTER AND ALDC Z103.** Align converter and ALDC amplifier Z103 as follows:

- (1) Connect converter and ALDC amplifier into an extender card.
- (2) Using an oscilloscope, measure 1.666 MHz input at J103-15. Input level shall be 0.3 volt peak-to-peak.
- (3) Connect oscilloscope probe to collector of transistor Q1 and adjust transformer T1 for maximum output (approximately 0.5 volt peak-to-peak).
- (4) Set the following front panel controls to minimum levels: RF OUTPUT, USB and LSB, MIKE GAIN and VOX GAIN.

- (5) Set MODE switch to USB position.
- (6) Set EXCITER switch to ON.
- (7) Set CARR SUPPR switch to variable, and carrier suppression control to minimum (fully counterclockwise).
- (8) Connect oscilloscope probe to cathode of diode CR1 (junction of CR1 and resistor R10). Adjust transformer T2 for maximum output.
- (9) Adjust potentiometer R6 for minimum 1.1.666 MHz signal. Repeat steps 8 and 9 until maximum tuning is obtained.
- (10) Connect oscilloscope on hot side of resistor R23 and adjust T3 for maximum output.
- (11) Connect oscilloscope to J103-A and adjust transformers T2 through T4 for maximum output. Output shall be approximately 0.7 volt peak-to-peak with a 250 kHz input of approximately 11 mv rms.

f. UPPER SIDEBAND GENERATOR Z105. (See figures 5-4 and 5-5.) Align upper sideband generator Z105 as follows:

- (1) Connect sideband generator Z105 into an extender cord.
- (2) Connect audio generator to Exciter MIKE input as shown in figure 5-4.
- (3) Adjust audio generator to a 1 kHz, 1.4 mv rms, measured at J105-D.
- (4) Connect meter to J105-A and adjust potentiometer R8 for 50 mv rms. Adjust USB meter GAIN control to obtain an indication of 1.0 on MONITOR meter.
- (5) Connect two-tone Audio generator (1.7 kHz and 0.7 kHz) to Exciter terminal board TB103 as shown in figure 5-5. Connect jumper between TB103-3 (ground) and TB103-4.
- (6) Adjust audio generator tone levels to 0.078 volt.
- (7) Set USB GAIN control to maximum counterclockwise position. MONITOR meter shall indicate 1 minimum.
- (8) Connect meter to J105-15 (250 kHz input). Input shall be 0.6 volt rms.
- (9) Set EXCITER switch to ON. Turn AGC potentiometer R56 fully clockwise.
- (10) Connect meter to base of transistor Q11 (R26) and adjust transformer T2 for maximum output.

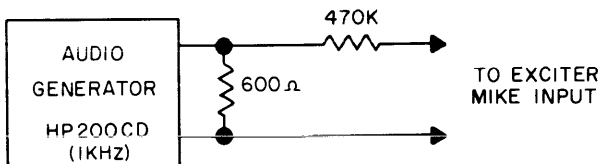

Figure 5-4. Audio and AM Amplifier Test Setup

- (11) Increase level of two tone signal input to obtain a MONITOR meter indication of 2.
- (12) Connect meter to collector of transistor Q12 (junction of R60 and R40). Adjust transformer T3 for maximum output.

(13) Connect meter to cathode of CR3 and adjust potentiometer R56 for reading of 0.2 volt rms; adjust transformer T4 for maximum indication.

(14) Connect meter to J105-11 and adjust potentiometer R56 for an output of 0.009 volt rms.

(15) Set EXCITER switch to PTT position. Adjust two-tone input to 0.078 volt rms.

(16) Connect ohmmeter across TB105-13 and TB205-14. Increase level of VOX gain control until meter indicates short circuit. The following conditions shall exist:

- TB105-13 and -14, short
- TB103-5 and -6, short
- J105-P, ground
- J105-H and -J, short
- J105-11, approximately 0.009 volt rms

(17) Decrease level of VOX gain control until meter indicates an open circuit. The following conditions shall exist:

- TB105-13 and -14, open
- TB103-5 and -6, open
- J105-P, open
- J105-H and -J, open
- J105-11, 0 volt

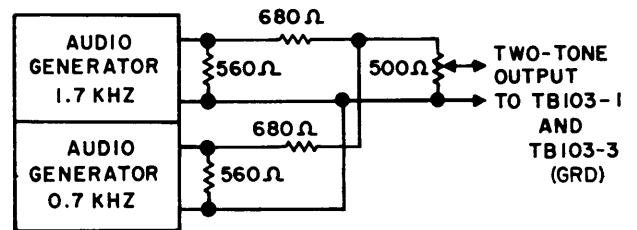

Figure 5-5. Sideband Generator Z105 Test Setup

g. LOWER SIDEBAND GENERATOR Z109. Align lower sideband generator Z109 following the procedure contained in paragraph f, substituting the following terminal board connections and control voltages:

J105 (USB)	J109 (LSB)
TB103-1	TB104-7
TB103-2	TB104-8
TB103-3	TB104-9
TB103-4	TB104-10
USB level control	LSB level control
	MODE and METER switches in LSB position

h. AM AMPLIFIER Z108. (See figure 5-4.) Align AM amplifier Z108 as follows:

(1) Connect oscilloscope between J108-L and ground. Oscilloscope shall indicate 250 kHz signal 1.5 volts peak-to-peak.

(2) Connect audio generator to Exciter MIKE input as shown in figure 5-4.

(3) Adjust audio generator input for 1 kHz at 40 mv rms.

(4) Set MODE switch to either USB or LSB; set METER switch to the corresponding position (USB or LSB).

(5) Using Exciter MIKE GAIN control, set mike gain for 2.8 mv at J108-15; MONITOR meter should indicate 0.7.

(6) Connect oscilloscope to hot side of R13 and adjust transformer T1 for maximum output.

(7) Connect Ballantine meter between J108-E and ground; adjust potentiometer R15 for 6.2 mv rms.

i. RF AMPLIFIER Z101, Z102 AND Z111 THROUGH Z113. Align the rf amplifier as follows:

(1) Connect rf amplifier into an extender card; into J101. Make sure Z115 is disconnected from the unit.

(2) Set CARR SUPP control to minimum suppression.

(3) Set the CHANNEL selector switch to 1.

NOTE

All odd numbered channels are the upper sections of the RF card. All even numbered channels are the lower sections of the RF card. The channel frequency is calculated as follows:

The oscillator frequency is a seven digit number; for example:

(1) - 7.783667MHz (2)- 17.78367MHz
1.416667MHz or 1.41667MHz
6.367000MHz 16.36700MHz

Subtract as shown.

The final figure is the rf frequency for the particular channel. For all oscillator frequencies of 10.00000MHz or higher, subtract 1.41667MHz. For all oscillator frequencies lower than 10.00000MHz subtract 1.416667MHz.

For the rest of this test procedure, assume the oscillator frequency is 7.783667, which will produce an rf frequency of 6.367000MHz. This frequency will only be used as an example, the tester will calculate the rf frequency for his oscillator and then proceed with the procedure using his calculated frequency.

(4) Adjust signal generator for 6.367000 MHz. Make sure RF OUTPUT control is set for minimum.

(5) Connect signal generator to junction of R40, R41 (270 Ω) and R39 (68 Ω).

(6) Connect high frequency scope between hot side of capacitor C2 and ground. Set generator gain for a scope reading of 0.1 volt peak-to-peak. Adjust C2 for maximum output.

(7) Place scope between hot side of capacitor C7 and ground; adjust C2 and C7 for maximum output. Keep level of generator adjusted so that maximum signal on scope is 0.1 volt peak-to-peak.

(8) Place scope between hot side of capacitor C14 and ground. Adjust capacitors C7 and C14 for maximum indication. Adjust potentiometer R9 to approximately mid range and adjust generator gain for 0.1 volt peak-to-peak.

(9) Place scope between hot side of capacitor C20 and ground. Adjust capacitors C14 and C20 for maximum indication on scope. Reduce generator for 0.1 volt peak-to-peak.

(10) Place scope between pin A and ground. Adjust capacitor C20 for maximum indication on scope.

(11) Disconnect generator and set front panel controls as follows:

- (a) EXCITER switch to ON position.
- (b) MODE switch to USB or LSB.
- (c) CHANNEL switch to channel 1 or any odd numbered channel corresponding to channel being tested.

- (d) VOX gain to OFF.
- (e) MIKE gain to center (0).
- (f) USB and LSB gain controls to

minimum.

- (g) RF output to maximum.

(12) Place scope across capacitor C7 and adjust C2 and C7 for maximum gain.

(13) Place scope across capacitor C14 and adjust C7 and C14 for maximum gain.

(14) Place scope across capacitor C20 and adjust C14 and C20 for maximum gain.

(15) Place scope between pin A and ground. Adjust capacitor C20 for maximum gain. Adjust potentiometer R9 for approximately 0.1 volt peak-to-peak.

(16) Repeat steps 7 through 15 for even channels. Adjust the following components:

<u>Even Channel Components</u>	<u>Odd Channel Components</u>
C2	C39
C7	C43
R9	R47
C14	C50
C20	C56

NOTE

This completes the alignment of the rf amplifier. Final adjustment of potentiometers R9 and R47 is performed in the final rf output Z115 procedure.

j. **FREQUENCY SHIFT GENERATOR Z107.**
(See figure 5-6.) Align the frequency shift generator as follows:

NOTE

FSK and FAX adjustments must be made after the 1.4166MHz oscillator oven has warmed up for at least an hour.

- (1) Place Z107 on extender card.
- (2) Connect frequency counter to vertical output terminals of scope. Place MODE switch in FSK position. On rear panel set R101 to mid-range; set SHIFT switch to ± 425 (maximum shift position); and set SENSE switch to + (up) position.
- (3) Place scope on J107-H and adjust potentiometer R16 for maximum level indication on the scope. Note location of adjustments as shown in figure 5-6. (These are 25-turn potentiometers.)

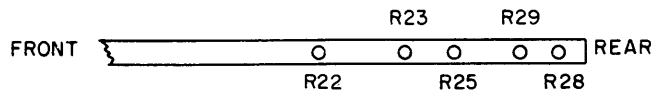

Figure 5-6. Frequency Shift Generator Adjustment Locations

- (4) Insert card into unit (not on extender). Set potentiometers R22 and R23 fully ccw.
- (5) Adjust potentiometer R25 for 1.41666 Hz reading on frequency counter.
- (6) Adjust potentiometer R23 for 1.416,241 Hz reading on frequency counter.
- (7) Set SENSE switch to - (down) position and adjust potentiometer R22 for 1,417,091 Hz on frequency counter.
- (8) Repeat steps (6) and (7) until frequencies are within 5 Hz.
- (9) Set SHIFT switch to ± 212 position (rear panel) and set SENSE switch to + position. Counter should read 1,416,454 ± 15 Hz.
- (10) Set SENSE switch to - (down) position. Counter should read 1,416,878 ± 15 Hz.
- (11) Repeat steps (9) and (10) for ± 106 Hz SHIFT switch position.
- (12) Repeat steps (9) and (10) for ± 53 Hz SHIFT switch position. Tolerance is ± 7 Hz.
- (13) Place MODE switch in FAX position and set potentiometer R28 fully cw.
- (14) Apply 0-10 volts power supply to FAX terminals on rear panel and set for 1.0 volt input.
- (15) Adjust potentiometer R29 for 1,416,266 ± 5 Hz reading on counter.
- (16) Reset input to 10.0 volts and adjust potentiometer R28 for 1,417,066 ± 5 Hz reading on counter.
- (17) Repeat steps (14) through (16).
- (18) Check for linearity by varying input from 1.0 to 10.0 volts. Counter should change 89 ± 5 Hz for every 1.0-volt change from 1.0 to 10.0 volts as shown in table 5-3.

TABLE 5-3. FAX VOLTAGE VS. FREQUENCY LINEARITY CHECK

Volts	Frequency
1	1,416,266 ± 5 cps
2	1,416,355 ± 5 cps
3	1,416,444 ± 5 cps
4	1,416,533 ± 5 cps
5	1,416,622 ± 5 cps
6	1,416,711 ± 5 cps
7	1,416,800 ± 5 cps
8	1,416,889 ± 5 cps
9	1,416,979 ± 5 cps
10	1,417,067 ± 5 cps

k. **RF OUTPUT Z115.** (See figure 5-5.) Align the rf output as follows:

- (1) Set up unit on LSB or USB with two tones as outlined in subparagraph f, steps (4) and (5).
 - (2) Before inserting card into unit, adjust potentiometers R1, R2 and R4 for maximum resistance.
 - (a) Turn RF OUTPUT control on front panel fully ccw.
 - (b) Set MODE switch to LSB or USB.
 - (c) Set USB or LSB gain control for level of 2.
 - (d) Set CARR SUPP control to minimum.
 - (e) Insert rf card into unit. Make sure power supply voltages are correct.
 - (f) Place 47-ohm load on RF OUT jack.
 - (g) Place HP VTVM (AC 10V range) across 47-ohm load.
 - (h) Set CHANNEL selector for any operating odd channel.
 - (3) Turn METER switch to Q1 position. On rf output Z115, adjust potentiometer R4 until front panel meter reads in the center of the green region marked Q1.
 - (4) Turn METER switch on front panel to Q2 and adjust potentiometer R2 until front panel meter reads in the center of the green region marked Q2.
 - (5) Turn METER switch on front panel to Q3 and adjust potentiometer R1 until front panel meter reads in center of the green region marked Q3.
 - (6) Turn up RF OUTPUT control until rf meter (HP VTVM) reads 3.6 volts rms.
 - (a) If output does not reach 3.6 volts rms, adjust potentiometer R9 of the RF amplifier card associated with the selected channel. With RF OUTPUT control at maximum gain, adjust potentiometer R9 of each odd channel for 3.6 volts rms and adjust potentiometer R47 of each even channel for 3.6 volts rms output.
1. **OVERALL CHECK.** Perform an overall check as follows:
- (1) Channel selector readout test:
 - (a) With power OFF, place ohmmeter at J119-BA.

(b) Place other lead of ohmmeter at J119-BB. With CHANNEL selector switch in the one (1) position there should be zero resistance. In all other channel positions, resistance should be infinity.

(c) Perform the same procedure for the following:

<u>Lead to Pin Number (J119)</u>	<u>Channel Position for Zero (0) Ohms</u>
BC	2
BD	3
BE	4
BF	5
BH	6
BJ	7
BK	8
BL	9
BM	10

(2) Two-tone test:

(a) Feed two tones into both lower and upper sideband terminals (600) on rear panel. USB terminals are TB103-1 and -3, with 3 connected to 4. LSB terminals are TB104-7 and -9, with 9 connected to 10. (See figure 5-5.)

(b) Connect analyzer to RF MON jack. Make sure RF OUT jack is terminated with 47 ohms.

(c) Set USB gain control for meter reading of 2. Set MODE switch to USB.

(d) Connect rf meter to 47-ohm load and turn up RF OUTPUT control to maximum. RF output should be 3.6 volts rms. Observe the following on the analyzer: two tones out; carrier suppression at least -60 db (with CARR SUPP control in maximum position); distortion should be -40 db or better.

NOTE

To observe distortion, the audio frequencies chosen for the two tones should be 700 cps and 1.3 kHz.

(e) Follow the same procedure for the lower sideband.

(f) Repeat steps (a) through (f) for all channels.

5-4. REPAIR OF PRINTED CIRCUITRY.

a. INTRODUCTION. Repair of the chassis-mounted power supply circuitry follows standard laboratory procedures. Repair of printed circuit cards and card receptacle wiring, however, require the special tools and techniques as outlined here. Section 6, Parts List, lists all replaceable parts and their circuit symbol numbers. These symbol numbers are shown on the schematics contained in Section 7 and located on figures 5-6 through 5-19.

NOTE

Replacement of parts on the printed circuit boards requires the special tools and techniques described in paragraph 5-4 d.

b. REPLACEMENT OF PARTS. When replacing a part on a board, it is necessary to remove the old part from the board by melting the solder on all the component pins. Soldering the new part to the board is done pin-by-pin with conventional methods.

c. CHECKING PRINTED CIRCUIT CONDUCTORS. Breaks in the conducting strip (foil) on a printed circuit board can cause permanent or intermittent trouble. In many instances, these breaks will be so small that they cannot be detected by the naked eye. These invisible cracks (breaks) can be located only with the aid of a powerful magnifying glass.

To check out and locate trouble in the conducting strips of a printed circuit board, set up a multimeter (one which does not use a current in excess of 1 ma) for making point-to-point resistance tests, using needle probes. Insert one point into the conducting strip, close to the end of terminal, and place the other probe on the terminal or opposite end of the conducting strip. The multimeter should indicate continuity. If the multimeter indicates an open circuit, drag the probe along the strip (or, if the conducting strip is coated, puncture the coating at intervals) until the multimeter indicates continuity. Mark this area; then use a magnifying glass to locate the fault in the conductor.

CAUTION

Before using an ohmmeter for testing a circuit containing transistors or other voltage-sensitive semiconductors, check the current it passes under test on all ranges. DO NOT use a range that passes more than 1 ma.

d. REPAIR OF PRINTED CONDUCTORS. If the break in the conductor strip is small, lightly scrape away any coating covering the area of the conducting strip to be repaired. Clean the area with a firm-bristly brush and approved solvent. Then repair the cracked or broken area of the conducting strip by flowing solder over the break. Considerable care must be exercised to keep the solder from flowing onto an adjacent strip.

If a strip is burned out, or fuses, cut and remove the damaged strip. Connect a length of insulated wire across the break or from solder-point to solder-point.

After the repairs are completed, clean the repaired area with a stiff brush and solvent. Allow the board to dry thoroughly, and then coat the repaired area with an epoxy resin or similar compound. This coating not only will protect the repaired area, but will help to strengthen it.

CAUTION

After repairs, check the board for solder drippings; they may cause shorts.

Frequently, a low-resistance leakage path will be created by moisture and/or dirt that has carbonized onto the phenolic board. This leakage can be detected by measuring the suspected circuit with a multimeter. To overcome this condition, thoroughly clean the carbonized area with solvent and a stiff brush. If this does not remove it, use a scraping tool (spade end of a solder-air tool or its equivalent) to remove the carbon or drill a hole through the leakage path to break the continuity of

the leakage. When the drilling method is used, be careful not to drill into a part mounted on the other side.



Figure 5-7. RF Output Waveform

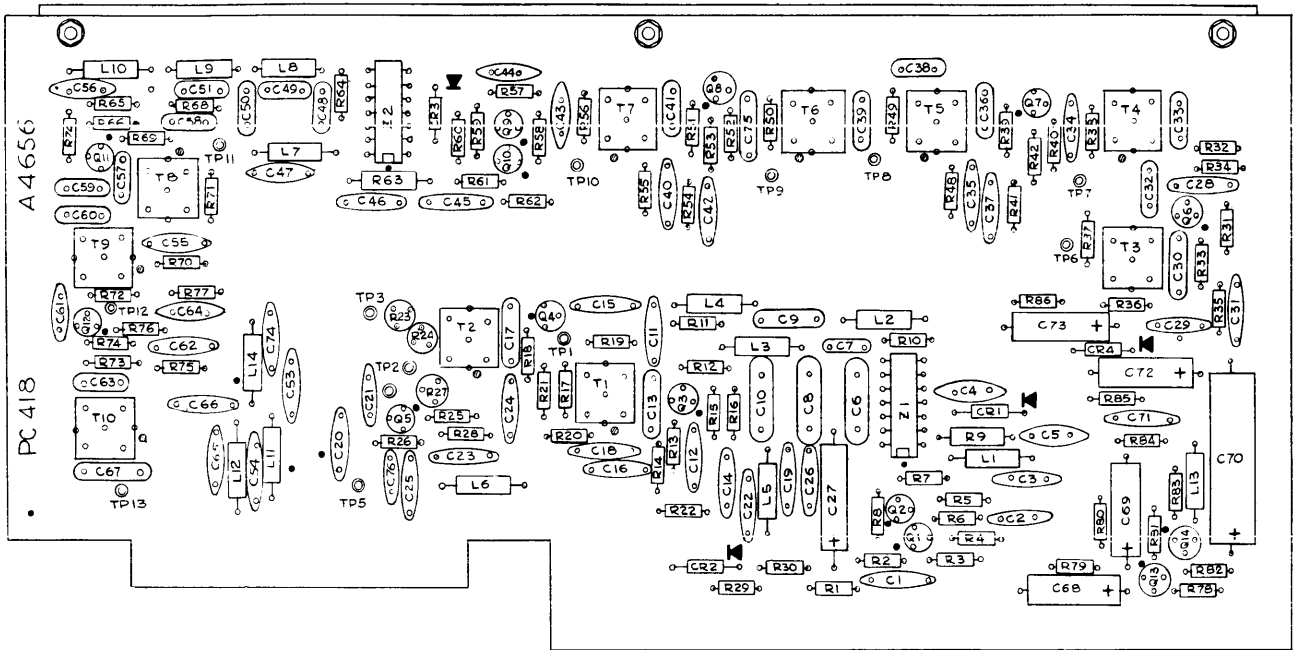

Figure 5-8. Carrier Generator Z101, Component Location

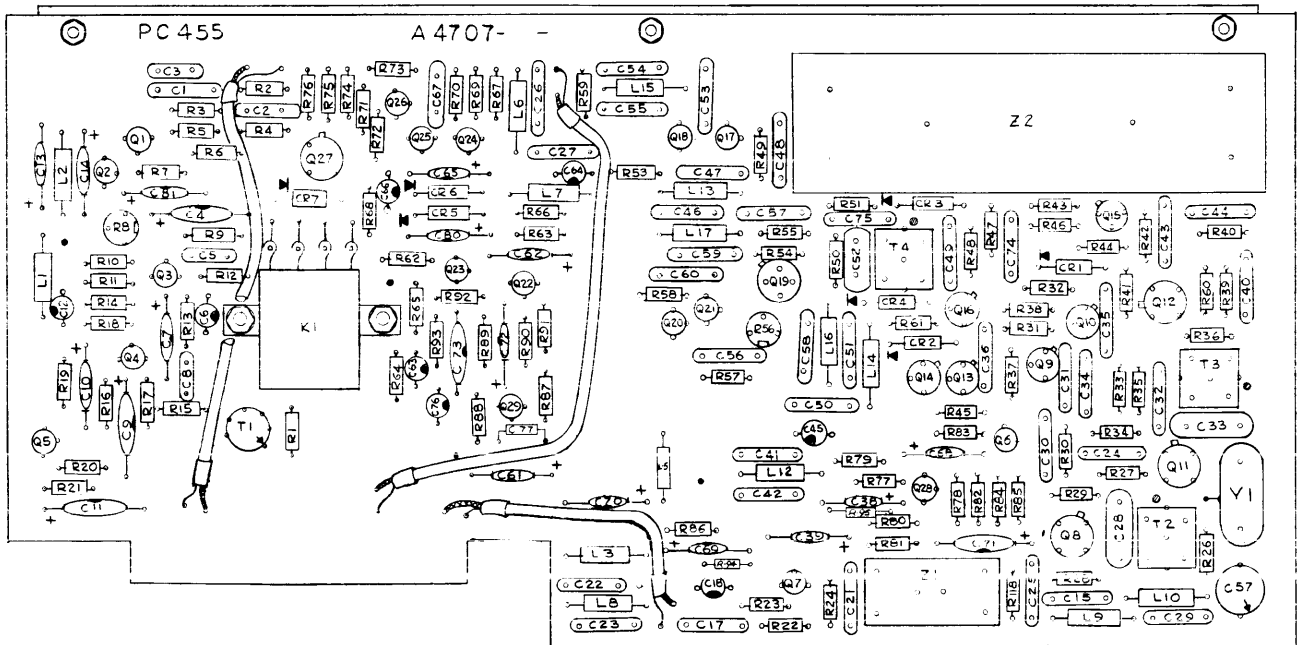

Figure 5-9. Sideband Generators Z105 and Z109, Component Location

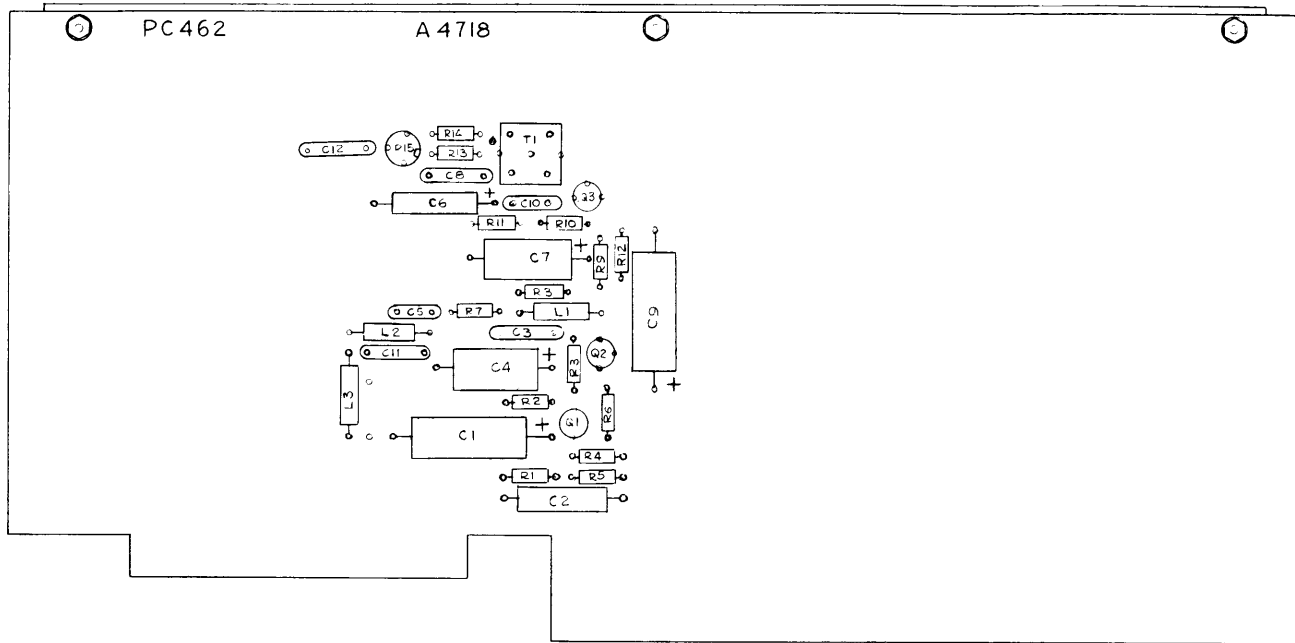

Figure 5-10. AM Amplifier Z108, Component Location

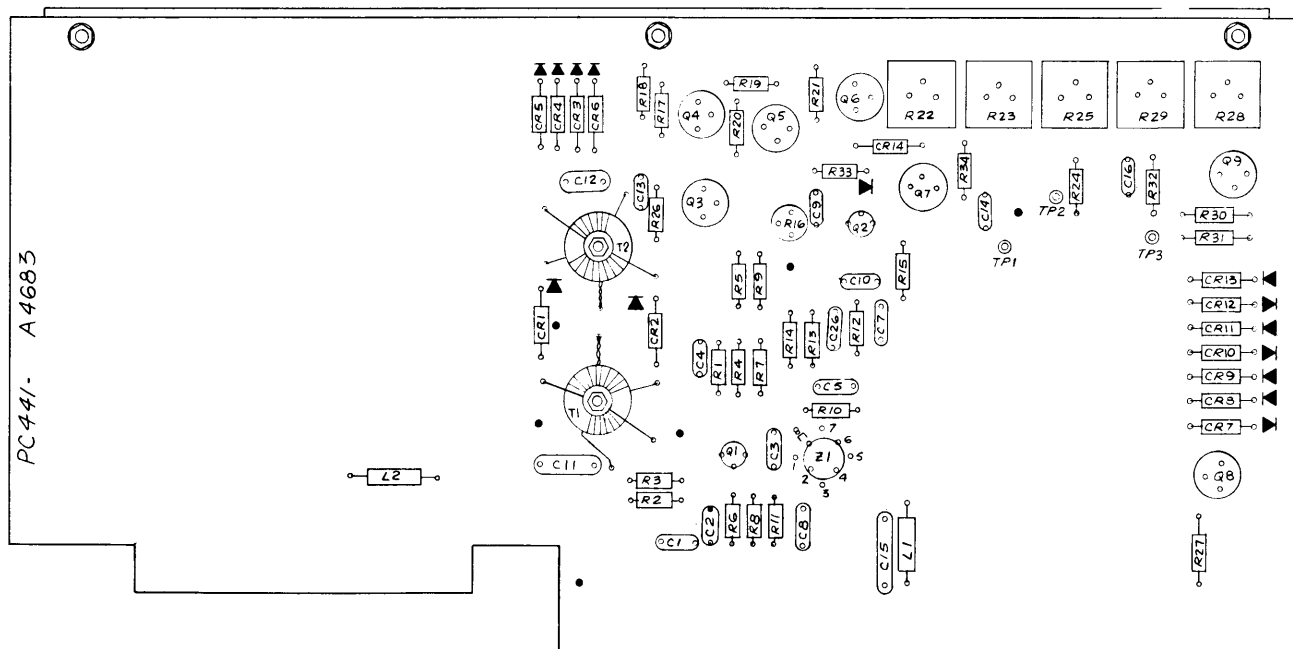

Figure 5-11. Frequency Shift Generator Z110, Component Location

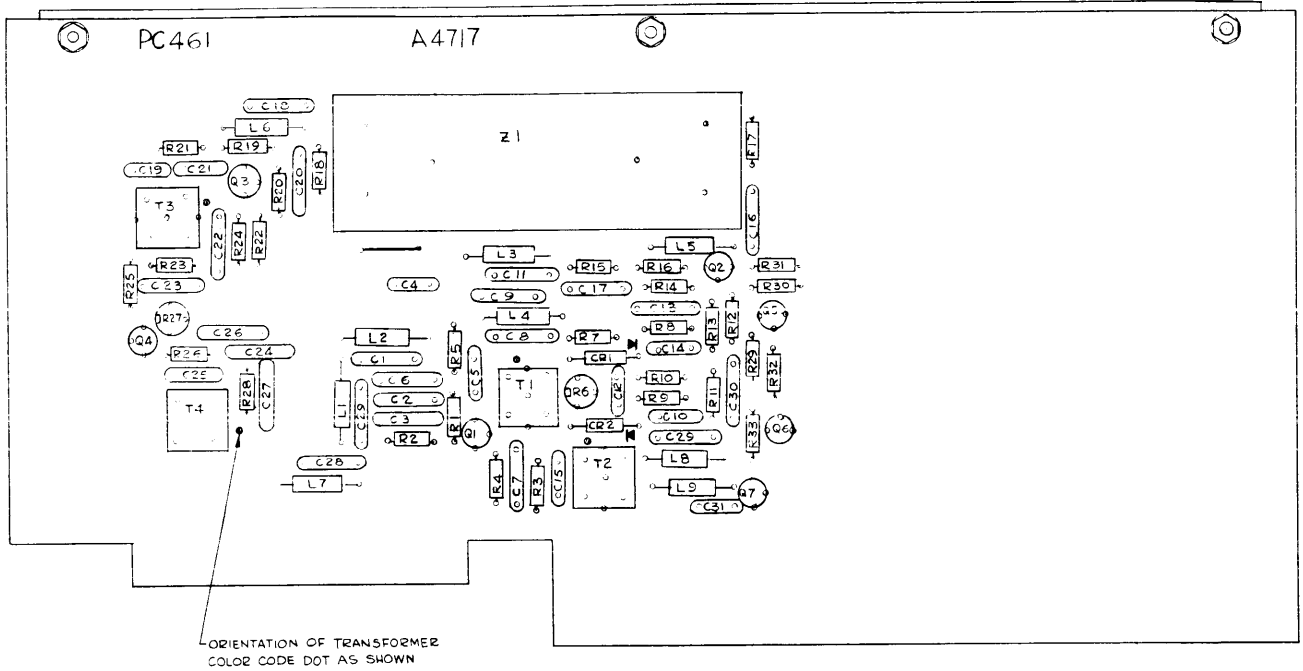

Figure 5-12. Converter and ALDC Z103, Component Location

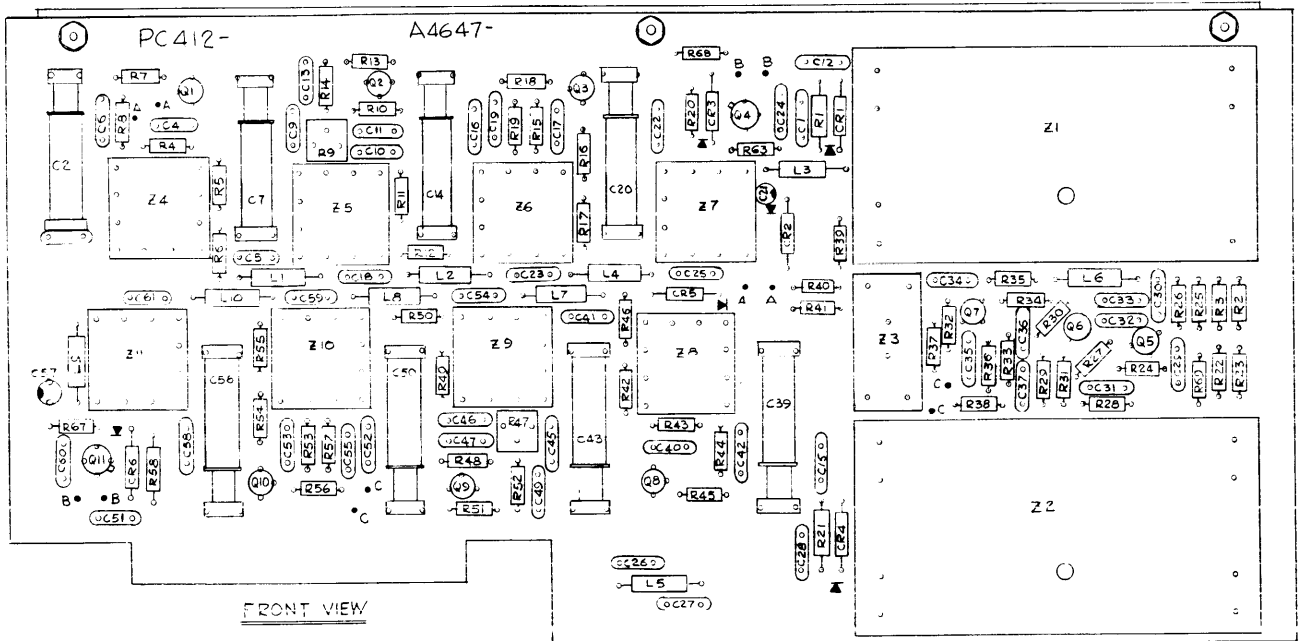

Figure 5-13. RF Amplifier Z101, Z102, Z111, Z112 and Z113, Component Location

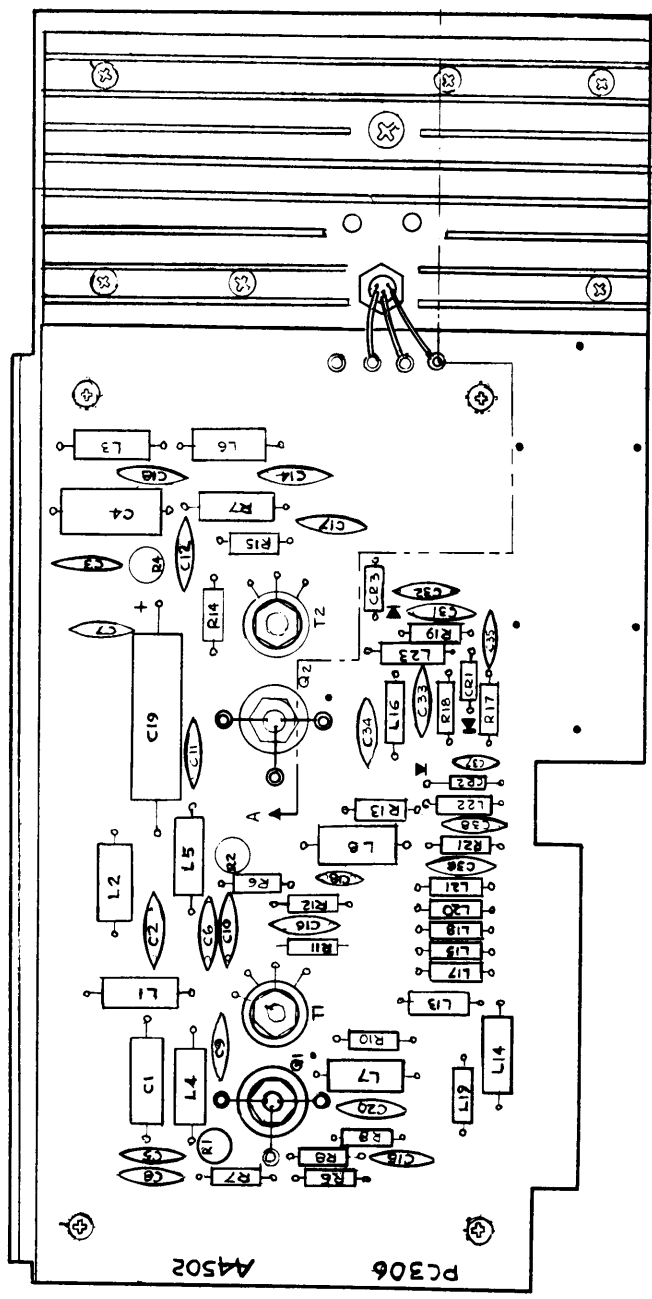

Figure 5-14. RF Output Z115, Component Location

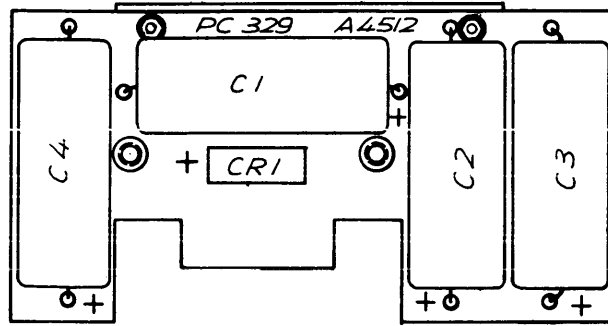

Figure 5-15. Rectifier-Filter Z304, Component Location

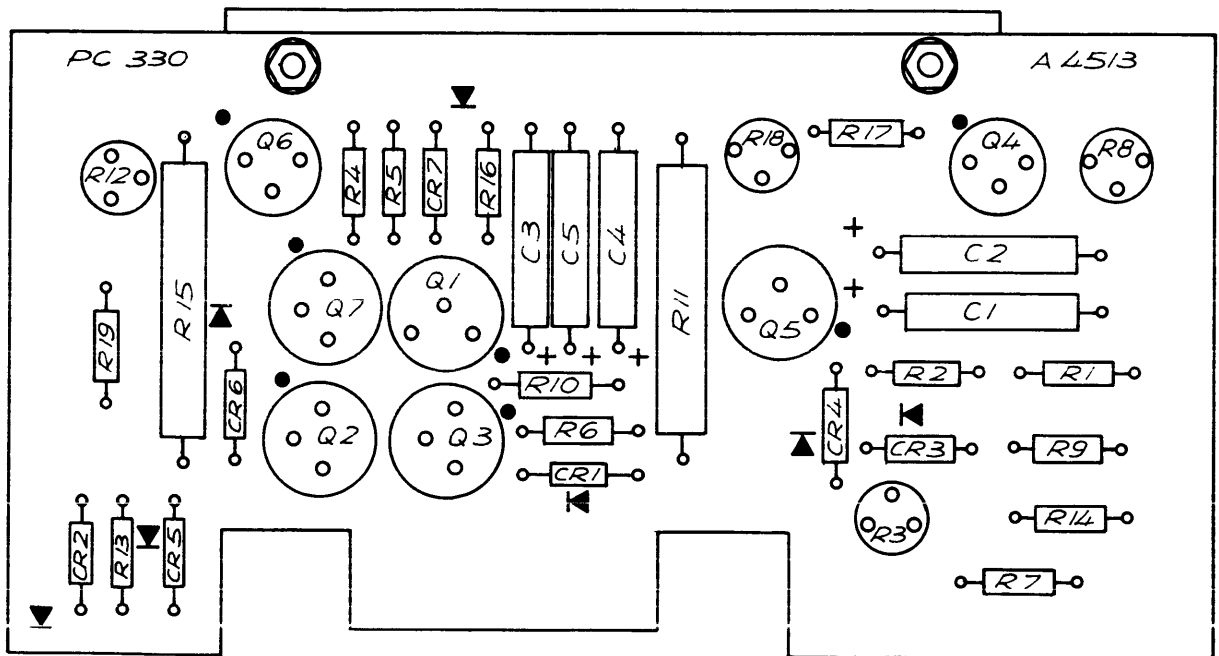

Figure 5-16. Regulator Z303, Component Location

SECTION 6

PARTS LIST

6-1. INTRODUCTION

The parts list presented in this section is a cross-reference list of parts identified by a reference designation and TMC part number. In most cases, parts appearing on schematic diagrams are assigned reference designations in accordance with MIL-STD-16. Wherever practicable, the reference designation is marked on the equipment, close to the part it identifies. In most cases, mechanical and electro-mechanical parts have TMC part numbers stamped on them.

To expedite delivery when ordering any part, specify the following:

- a. Reference symbol.
- b. Description as indicated in parts list.
- c. TMC part number.
- d. Model and serial numbers of the equipment containing the part being replaced; this can be obtained from the equipment nameplate.

For replacement parts not covered by warranty (refer to warranty sheet in front of manual), address all purchase orders to:

The Technical Materiel Corporation
 Attention: Sales Department
 700 Fenimore Road
 Mamaroneck, New York

The following assemblies are standard in all configurations of the SME()-6:

<u>Assembly or Sub-Assembly:</u>	<u>Page</u>
SME()-6, Main Chassis	6-2
A4656, Carrier Generator, (Z104)	6-8
A4717, Converter and ALDC, (Z103)	6-16
A4647, RF Amplifier, (Z101)	6-20
A4502, RF Output, (Z115)	6-25
AP143, Power Supply	6-28
A4512, PC Board "A" (Power Supply), (Z304)	6-29
A4513, PC Board "A" (Power Supply), (Z303)	6-30

The following additional assemblies are customer-specified options:

<u>Assembly or Sub-Assembly:</u>	<u>Page</u>
A4707, Sideband Generator, (Z105 and/or Z109)	6-32
A4718, AM Amplifier, (Z108)	6-41
A4683, Frequency Shift Generator	6-43
A4647, Amplifier, (Additional channel capability; any or all of the following: Z102, Z111-113)	6-20

SME()-6 MAIN CHASSIS

REF SYMBOL	DESCRIPTION	TMC PART NUMBER
	SW. ASS'Y, <u>AS131</u>	
R114	Res, Fxd, Comp, 47000 ohms, <u>+5%</u> , 1/4 watt	RC07GF473J
R115	Same as R114	
R116	Res, Fxd, Comp, 1000 ohms, <u>+5%</u> , 1/4 watt	RC07GF102J
R117	Same as R116	
R118	Res, Fxd, Comp, 2200 ohms, <u>+5%</u> , 1/4 watt	RC07GF222J
R119	Same as R118	
S110	Switch, Rotary, 1 Section, 30° angle of throw	SW447
	SW. ASS'Y, <u>AS136</u>	
R120	Res, Fxd, Comp, 10000 ohms, <u>+ 5%</u> , 1/4 watt	RC07GF103J
R121	Res, Fxd, Comp, 100000 ohms, <u>+ 5%</u> , 1/4 watt	RC07GF104J
R122	Res, Fxd, Comp, 47000 ohms, <u>+ 5%</u> , 1/4 watt	RC07GF473J
R123	Res, Fxd, Comp, 2700 ohms, <u>+ 5%</u> , 1/4 watt	RC07GF272J
R124	Res, Fxd, Comp, 150 ohms, <u>+5 %</u> , 2 watt	RC42GF151J
R125	Same as R124	
S111	Switch, Rotary, 1 Section, 30° angle of throw	SW446
	SW. ASS'Y, <u>AS137</u>	
R143	Res, Fxd, Comp, 300000 ohms, <u>+5%</u> , 1/4 watt	RC07GF304J
S104	Sw. Rotary	SW476

SME()-6 MAIN CHASSIS

REF SYMBOL	DESCRIPTION	TMC PART NUMBER
SW. ASS'Y, <u>AS138</u>		
R108	Res, Fxd, Comp, 680 ohms, $\pm 5\%$, 1/4 watt	RC07GF681J
R109	Res, Fxd, Comp, 220 ohms, $\pm 5\%$, 1/4 watt	RC07GF221J
R110	Same as R109	
R111	Res, Fxd, Comp, 2200 ohms, $\pm 5\%$, 1/4 watt	RC07GF222J
R112	Res, Fxd, Comp, 390 ohms, $\pm 5\%$, 1/4 watt	RC07GF391J
S103	Switch, Rotary, 12 Point Type	SW474
SW. ASS'Y, <u>AS139</u>		
R128	Res, Fxd, Comp, 10000 ohms, $\pm 5\%$, 1/4 watt	RC07GF103J
R129	Res, Fxd, Comp, 1000 ohms, $\pm 5\%$, 1/4 watt	RC07GF102J
R130	Same as R129	
R131	Same as R128	
R132	Same as R128	
R133	Same as R128	
R134 thru R137	Same as R129	
R138	Res, Fxd, Comp, 220 ohms, $\pm 5\%$, 1/4 watt	RC07GF221J
S102	Switch, Rotary, 5 Section, 30° angle of throw	SW475
J101 J102 thru J105	Conn, Recp, Fml, 30 double contacts Same as J101	JJ319A15DFE

SME()-6 MAIN CHASSIS

REF SYMBOL	DESCRIPTION	TMC PART NUMBER
J107 thru J109	Same as J101	
J111 thru J115	Same as J101	
C101 thru C103	Cap, Fxd, Mica, 1000 uuf, \pm 10%, 300 WVDC	CB21QB102K
C104	Cap, Fxd, Ceramic	CC100-24
C107 and C109	Same as C101	
C110	Same as C104	
C111	Same as C101	
C113 and C114	Same as C101	
C116	Same as C101	
C117	Same as C101	
C126	Same as C101	
CR101	Semiconductor, Device, Diode	1N914
CR102	Same as CR101	
DS101	Lamp, Incand, 28.0 Volts, ac/dc, .04 amps.,	BI110-7
DS102	Same as DS101	
F101 and F102	Fuse, CTG, 1 amp at 220 Volts	FU102-1.00

SME()-6 MAIN CHASSIS

REF SYMBOL	DESCRIPTION	TMC PART NUMBER
J116	Conn, Recp, Male, 3 contacts	MS3102A16S5P
J117	Jack, Tel., Key	JJ034
J118	Jack, Tel., Mike	JJ033
J119	Conn, Recep, Male	JJ333-104P-FS-4
J120 thru J121	Conn, Recep, PF, 1 female contact, 52 ohms, BNC type	UG625/U
J123 thru J125	Same as J120	
K101	Relay, Arm., Min.	RL143-4
K102	Relay	RL156-5
L101 thru L103	Coil, RF, Fixed; 120 uh, 315 ma, 10 mc	CL240-120
L107 thru L109	Same as L101	
L111	Same as L101	
L113	Same as L101	
L114	Same as L101	
L116	Same as L101	
L117	Same as L101	
M101	Meter	MR191-9
P305	Conn, Pl, Min, 1500 VRMS, 48 ohms (impedance) Oper. Volt. - 500 VRMS.	PL204
R101	Res, Var, Comp, 1000 ohms, \pm 10%, 1/2 watt	RV100UX8B10ZA

SME()-6 MAIN CHASSIS

REF SYMBOL	DESCRIPTION	TMC PART NUMBER
R102	Res, Var, Comp, 100 ohms, $\pm 10\%$, 2 watts	RV4NAYS101A
R103 and R104	Res, Var, Comp, 500 ohms, $\pm 20\%$, 2 watts	RV4ATRD501B
R105	Res, Var, Comp, 25000 ohms, $\pm 10\%$, 2 watts	RV4NAYS253A
R106	Same as R102	
R107A and R107B	Res, Var, Comp, 500 VRMS, $\pm 10\%$, 2 watts	RV108-2
R113 and R114	Res, Fxd, Comp, 1200 ohms, $\pm 5\%$, 1/4 watt	RC07GF122J
R139 and R140	Res, Fxd, Comp, 2200 ohms, $\pm 5\%$, 1/2 watt	RC20GF222J
R141	Res, Fxd, Comp, 470 ohms, $\pm 5\%$, 1/2 watt	RC20GF471J
R142	Res, Var, Comp, 10000 ohms, $\pm 10\%$, 2 watt	RV106UX8B103A
S101	SW. Rotary, Channel	SW473
S109	SW. Toggle, SPDT	ST103-11-62
S112 and S113	SW. Toggle, DPDT	ST22N
TB103	Term. Bd.-Barr.; bright nickel plate	TM100-6
TB104 and TB105	Same as TB103	
XDS101	Lamp, Ind-Red, 2 terminals, T=1-3/4 Lamp BPSE	TS153-2

SME()-6 MAIN CHASSIS

REF SYMBOL	DESCRIPTION	TMC PART NUMBER
XDS102	Lamp, Ind-Wht; 2 terminals, T=1-3/4 Lamp BPSE	TS153-5
XF101	Fuse Holder	FH104-3
XF102	Same as XF101	
Z301	Oscillator, Ovenized; 1 MHz standard.	NF116-1
Z302*	Oscillator; 1.41666 MHz*	AO126*
Z305	Heat Sink Assembly; consists of:	
P306	Conn, Recp, Male	PL225-8P
Q301	Transistor, Silicon, NPN	2N1488
Q302	Same as Q301	
Q303	Same as Q301	
<p>* - Optional Main Chassis component supplied with Frequency Shift Generator A4683, as part of FSK/FAX option package.</p>		

A4656

REF SYMBOL	DESCRIPTION	TMC PART NUMBER
C1	Cap, Disc, Cer, 100,000 uuf, +80-20%, 25 WVDC	CC100-44
C2	Cap, Disc, Cer, 10000 uuf, +80-20%, 500 WVDC	CC100-16
C3 thru C5	Same as C2	
C6	Cap, Fxd, Mica, 2700 uuf, <u>+1%</u> , 500 WVDC	CM112F272F5S
C7	Cap, Fxd, Mica, 680 uuf, <u>+1%</u> , 300 WVDC	CM111F681J3S
C8	Cap, Fxd, Mica, 3900 uuf, <u>+1%</u> , 300 WVDC	CM112F392G3S
C9	Cap, Fxd, Mica, 1300 uuf, <u>+1%</u> , 500 WVDC	CM112F132F5S
C10	Cap, Fxd, Mica, 3600 uuf, <u>+1%</u> , 500 WVDC	CM112F362G5S
C11 and C12	Same as C1	
C13	Same as C8	
C14 thru C16	Same as C1	
C17	Same as C8	
C18 thru C20	Same as C1	
C21	Same as C2	
C22 thru C26	Same as C1	
C27	Cap, Elec, 10 ufd, 25 WVDC	CE105-10-25
C28	Same as C1	
C29	Same as C2	
C30	Cap, Fxd, Mica, 300 uuf, <u>+5%</u> , 500 WVDC	CM11E301J5S

A4656

REF SYMBOL	DESCRIPTION	TMC PART NUMBER
C31	Same as C2	
C32	Cap, Fxd, Mica, 15 uuf, <u>+5%</u> , 500 WVDC	CM111C150J5S
C33	Same as C30	
C34 and C35	Same as C2	
C36	Same as C30	
C37	Same as C2	
C38	Same as C32	
C39	Same as C30	
C40	Same as C1	
C41	Same as C30	
C42	Same as C2	
C43	Same as C2	
C44	Cap, Disc, Cer, 1000 uuf, <u>+80-20%</u> ,	CC100-29
C45 thru C47	Same as C1	
C48	Cap, Fxd, Mica, 470 uuf. <u>+1%</u> , 500 WVDC	CM111F471F5S
C49	Cap, Fxd, Mica, 51 uuf, <u>+2%</u> , 500 WVDC	CM111E510G5S
C50	Same as C7	
C51	Cap, Fxd, Mica, 82 uuf, <u>+1%</u> , 500 WVDC	CM111E820F5S
C52	Cap, Fxd, Mica, 600 uuf, <u>+5%</u> , 300 WVDC	CM111F601J3
C53 thru C56	Same as C2	
C57	Cap, Fxd, Mica, 910 uuf, <u>+5%</u> , 100 WVDC	CM111F911J1S
C58	Same as C2	

A4656

REF SYMBOL	DESCRIPTION	TMC PART NUMBER
C59	Same as C49	
C60	same as C57	
C61 and C62	Same as C2	
C63	Cap, Fxd, Mica, 1000 uuf, <u>+1%</u> , 100 WVDC	CM111F102F1
C64 thru C66	Same as C2	
C67	Same as C1	
C68	Same as C27	
C69	Same as C27	
C70	Cap, Elec, 150 ufd, 15 WVDC	CE105-150-15
C71	Same as C2	
C72	Cap, Elec, 2 mfd, 50 WVDC	CE105-2-50
C73	Same as C72	
C74	Same as C1	
C75	Same as C2	
C76	Same as C1	
CR1	Diode, Ref, Silicon	1N751
CR2	Diode, Silicon, Computer Diode	1N914
CR3	Same as CR1	
CR4	Diode, GE, Silicon	1N34A
L1	Coil, 1,000 uh, <u>+10%</u> , 135 ma	CL275-102
L2	Coil, 180 uh, <u>+10%</u> , 260 ma	CL275-181
L3	Same as L2	

A4656

REF SYMBOL	DESCRIPTION	TMC PART NUMBER
L4	Coil, 1500 uh, <u>+10%</u> , 275 ma	CL275-151
L5 thru L7	Same as L1	
L8	Coil, 33 uh, <u>+10%</u> , 505 ma,	CL275-330
L9	Same as L8	
L10	Coil, 22 uh, <u>+10%</u> , 565 ma	CL275-220
L11 and L12	Same as L1	
L13	Coil, 220 uh, <u>+10%</u> , 250 ma	CL275-221
L14	Same as L1	
Q1	Transistor, Silicon, Epox	2N3646
Q2 thru Q14	Same as Q1	
R1	Res, Fxd, Comp, 470 ohms, <u>+5%</u> , 1/4 watt	RC07GF471J
R2	Res, Fxd, Comp, 47 ohms, <u>+5%</u> , 1/4 watt	RC07GF470J
R3	Res, Fxd, Comp, 100000 ohms, <u>+5%</u> , 1/4 watt	RC07GF104J
R4	Same as R3	
R5	Res, Fxd, Comp, 10000 ohms, <u>+5%</u> , 1/4 watt	RC07GF103J
R6	Res, Fxd, Comp, 2200 ohms, <u>+5%</u> , 1/4 watt	RC07GF222J
R7	Res, Fxd, Comp, 3900 ohms, <u>+5%</u> , 1/4 watt	RC07GF392J

A4656

REF SYMBOL	DESCRIPTION	TMC PART NUMBER
R8	Same as R6	
R9	Res, Fxd, Comp, 150 ohms, <u>+5%</u> , 1/2 watt	RC20GF151J
R10	Same as R6	
R11	Res, Fxd, Comp, 220 ohms, <u>+5%</u> , 1/4 watt	RC07GF221J
R12	Same as R5	
R13	Res, Fxd, Comp, 33000 ohms, <u>+5%</u> , 1/4 watt	RC07GF333J
R14	Res, Fxd, Comp, 1,000 ohms, <u>+5%</u> , 1/4 watt	RC07GF102J
R15	Res, Fxd, Comp, 100 ohms, <u>+5%</u> , 1/4 watt	RC07GF101J
R16	Same as R14	
R17	Same as R15	
R18	Same as R13	
R19	Same as R5	
R20	Same as R14	
R21	Same as R15	
R22	Same as R14	
R23	Res, Var, 100 ohms, <u>+30%</u> , 1/2 watt	RV124-101
R24	Res, Var, 500 ohms, <u>+30%</u> , 1/2 watt	RV124-501
R25	Same as R5	
R26	Same as R7	
R27	Same as R24	
R28	Same as R14	
R29	Same as R14	
R30	Same as R14	
R32	Same as R2	
R33	Same as R13	

A4656

REF SYMBOL	DESCRIPTION	TMC PART NUMBER
R34	Same as R5	
R35	Same as R14	
R36	Same as R14	
R37	Res, Fxd, Comp, 150 ohms, <u>+5%</u> , 1/4 watt	RC07GF151J
R38	Res, Fxd, Comp, 120 ohms, <u>+5%</u> , 1/4 watt	RC07GF121J
R39	Same as R13	
R40	Same as R5	
R41	Same as R14	
R42	Same as R2	
R48	Same as R14	
R49	Same as R37	
R51	Same as R13	
R52	Same as R5	
R53	Same as R2	
R54	Same as R14	
R55	Same as R14	
R56	Same as R15	
R57	Same as R3	
R58	Same as R3	
R59	Same as R6	
R60	Same as R5	
R61	Same as R7	
R62	Same as R6	
R63	Same as R9	

A4656

REF SYMBOL	DESCRIPTION	TMC PART NUMBER
R64	Same as R5	
R65	Same as R11	
R66	Same as R5	
R68	Same as R14	
R69	Same as R15	
R70	Same as R14	
R71	Res, Fxd, Comp, 180 ohms, <u>+5%</u> , 1/4 watt	RC07GF181J
R72	Same as R71	
R73	Same as R5	
R74	Same as R13	
R75	Same as R1	
R76	Same as R15	
R77	Same as R1	
R78	Res, Fxd, Comp, 22000 ohms, <u>+5%</u> , 1/4 watt	RC07GF223J
R79	Res, Fxd, Comp, 6800 ohms, <u>+5%</u> , 1/4 watt	RC07GF682J
R80	Res, Fxd, Comp, 1200 ohms, <u>+5%</u> , 1/4 watt	RC07GF122J
R81	Same as R15	
R82	Res, Fxd, Comp, 3300 ohms, <u>+5%</u> , 1/4 watt	RC07GF332J
R83	Same as R15	
R84	Res, Fxd, Comp, 4700 ohms, <u>+5%</u> , 1/4 watt	RC07GF472J
R85	Same as R5	
R86	Same as R5	
R87	Same as R38	
R88	Same as R13	

A4656

REF SYMBOL	DESCRIPTION	TMC PART NUMBER
T1	Transformer RF, Tuned	TT285012
T2	Transformer RF, Tuned	TT285-11
T3	Transformer RF, Tuned	TT296-6
T4	Same as T3	
T5 thru T7	Same as T3	
T8	Transformer RF, Tuned	TT296-4
T9	Same as T8	
T10	Transformer, RF, Tuned	TT296-5
Z1	Dual, Flip, Flop	NW159
Z2	Same as Z1	

A4717

REF SYMBOL	DESCRIPTION	TMC PART NUMBER
C1	Cap, Fxd, Cer, 100,000 uuf, +80-20%, 25 WVDC	CC100-44
C2 and C3	Same as C1	
C4	Cap, Fxd, Cer, 10000 uuf, +20-20%, 50 WVDC	CC100-42
C5	Cap, Fxd, Mica, 1000 uuf, <u>+1%</u> , 100 WVDC	CM111F102F1
C6 and C7	Same as C1	
C8 and C9	Cap, Fxd, Mica, 6800 uuf, <u>+2%</u> , 500 WVDC	CM112F682G5
C10	Same as C4	
C11	Same as C1	
C12	Cap, Fxd, Cer, 20000 uuf, +80-20%, 25 WVDC	CC100-40
C13	Same as C1	
C14	Same as C4	
C15	Cap, Fxd, Cer, 750 uuf, <u>+5%</u> , 300 WVDC	CM111F751J3
C16 thru C18	Same as C1	
C19	Cap, Fxd, Cer, 1000 uuf, +80-20%	CC100-29
C20	Same as C1	
C21	Same as C15	
C22 and C23	Same as C1	
C24	Cap, Fxd, Cer, 100000 uuf, +80-20%, 100 WVDC	CC100-28
C25	Same as C15	

A4717

REF SYMBOL	DESCRIPTION	TMC PART NUMBER
C26	Same as C1	
C27	Same as C24	
C28	Same as C24	
C29 and C30	Same as C1	
C31	Same as C4	
CR1	Diode, GE, From 0-10 ma, Forward Current within 30 MV at a Forward Voltage of 5V	DD139
CR2	Same as CR1	
L1 thru L3	Coil, 1000 UH, <u>+20%</u> , 135 ma	CL275-102
L4	Coil, 68 uuf, <u>+ 10%</u>	CL275-680
L5 thru L7	Same as L1	
L8	Coil, 120 uh, <u>+10%</u> , 20 ma	CL275-121
L9	Coil, 2220 uh, <u>+10%</u> , 250 ma	CL275-221
Q1	Transistor, Sil, Epox	2N3646
Q2 and Q3	Same as Q1	
Q4	Transistor, Sil, Metal	2N3295
Q5 thru Q7	Same as Q1	
R1	Res, Fxd, Comp, 22000 ohms, <u>+5%</u> , 1/4 watt	RC07GF223J
R2	Res, Fxd, Comp, 5600 ohms, <u>+5%</u> , 1/4 watt	RC07GF562J
R3	Res, Fxd, Comp, 470 ohms, <u>+5%</u> , 1/4 watt	RC07GF471J

A4717

REF SYMBOL	DESCRIPTION	TMC PART NUMBER
R4	Res, Fxd, Comp, 10 ohms, <u>+5%</u> , 1/4 watt	RC07GF100J
R5	Res, Fxd, Comp, 1000 ohms, <u>+5%</u> , 1/4 watt	RC07GF102J
R6	Res, Var, 500 ohms, <u>+30%</u>	RV124-1-501
R7	Res, Fxd, Comp, 120 ohms, <u>+5%</u> , 1/4 watt	RC07GF121J
R8*	Res, Fxd, Comp,	RC07GFXXXJ
R9	Same as R5	
R10	Res, Fxd, Comp, 100 ohms, <u>+5%</u> , 1/4 watt	RC07GF101J
R11	Res, Fxd, Comp, 27000 ohms, <u>+5%</u> , 1/4 watt	RC07GF273J
R12	Res, Fxd, Comp, 22 ohms, 1/4 watt	RC07GF220J
R13	Res, Fxd, Comp, 100000 ohms, <u>+5%</u> , 1/4 watt	RC07GF104J
R14	Same as R5	
R15	Res, Fxd, Comp, 180 ohms, <u>+5%</u> , 1/4 watt	RC07GF181J
R16	Same as R4	
R17	Same as R5	
R18	Res, Fxd, Comp, 1500 ohms, <u>+5%</u> , 1/4 watt	RC07GF152J
R19	Res, Fxd, Comp, 12000 ohms, <u>+5%</u> , 1/4 watt	RC07GF123J
R20	Res, Fxd, Comp, 2700 ohms, <u>+5%</u> , 1/4 watt	RC07GF272J
R21	Same as R3	
R22	Res, Fxd, Comp, 15 ohms, <u>+5%</u> , 1/4 watt	RC07GF150J
R23	Res, Fxd, Comp, 220 ohms, <u>+5%</u> , 1/4 watt	RC07GF221J
R24	Res, Fxd, Comp, 560 ohms, <u>+5%</u> , 1/4 watt	RC07GF561J
R25	Res, Fxd, Comp, 15000 ohms, <u>+5%</u> , 1/4 watt	RC07GF153J
R26	Same as R11	
R27	Same as R6	

A4717

REF SYMBOL	DESCRIPTION	TMC PART NUMBER
R28	Same as R5	
R29	Res, Fxd, Comp, 820000 ohms, <u>+5%</u> , 1/4 watt	RC07GF824J
R30	Res, Fxd, Comp, 330000 ohms, <u>+5%</u> , 1/4 watt	RC07GF334J
R31	Res, Fxd, Comp, 220000 ohms, <u>+5%</u> , 1/4 watt	RC07GF224J
R32	Res, Fxd, Comp, 10000 ohms, <u>+5%</u> , 1/4 watt	RC07GF103J
R33	Res, Fxd, Comp, 4700 ohms, <u>+5%</u> , 1/4 watt	RC07GF472J
R34	Same as R3	
T1	Transformer, Var,	TT296-1
T2	Transformer, Var	TT296-2
T3 and T4	Transformer, Var	TT296-3
Z1	Filter Band Pass	FX286

REF SYMBOL	DESCRIPTION	TMC PART NUMBER
C1	Cap, Fxd, comp, 10000 PF, <u>+20%</u> , 100 WVDC	CC-100-43
C2	Cap, Var, Glass, 1.0-52.0 PF, 1000 WVDC	CV116-2
C4 thru C6	Same as C1	
C7	Same as C2	
C9 thru C13	Same as C1	
C14	same as C2	
C15 thru C19	Same as C1	
C20	Same as C2	
C21	Cap, Fxd, Elec, 4 mfd, +50-20%, 35 WVDC	CE122-4-35
C22 thru C37	Same as C1	
C39	Same as C2	
C40 thru C42	Same as C1	
C43	Same as C2	
C45 thru C49	Same as C1	
C50	Same as C2	
C51 thru C55	Same as C1	
C56	Same as C2	

REF SYMBOL	DESCRIPTION	TMC PART NUMBER
C57	same as C21	
C58 thru C61	Same as C1	
CR1	Diode, Semiconductor Device, Voltage Regulator	IN759A
CR2	Diode, Semiconductor Device,	IN914
CR3	Same as CR2	
CR4	Same as CR1	
CR5	Same as CR2	
CR6	Same as CR2	
L1	Coil, Radio Frequency, 120 uh, <u>+20%</u> , 20ma	CL275-121
L2 thru L10	Same as L1	
Q1	Transistor, Silicon	2N3646
Q2	Same as Q1	
Q3	Same as Q1	
Q4	Transistor, Metal	2N5179
Q5 thru Q10	Same as Q1	
Q11	Same as Q4	
R1	Res, Fxd, Comp, 470 ohms, <u>+ 5%</u> , 1/2 watt	RC20GF471J
R2	Res, Fxd, Comp, 47 ohms, <u>+ 5%</u> , 1/4 watt	RC07GF470J
R3	Res, Fxd, Comp, 560 ohms, <u>+ 5%</u> , 1/4 watt	RC07GF561J
R4	Res, Fxd, Comp, 3900 ohms, <u>+5%</u> , 1/4 watt	RC07GF392J
R5	Res, Fxd, Comp, 22000 ohms, <u>+ 5%</u> , 1/4 watt	RC07GF223J

A4647

REF SYMBOL	DESCRIPTION	TMC PART NUMBER
R6	Res, Fxd, Comp, 1000 ohms, <u>+5%</u> , 1/4 watt	RC07GF102J
R7	Res, Fxd, Comp, 22 ohms, <u>+5%</u> , 1/4 watt	RC07GF220J
R8	Res, Fxd, Comp, 470 ohms, <u>+5%</u> , 1/4 watt	RJ07GF471J
R9	Res, Var, Comp, 500 ohms, <u>+30%</u> , 1/2 watt	RV124-2-501
R10	Same as R4	
R11	Same as R5	
R12	Same as R6	
R13	Same as R7	
R14	Same as R8	
R15	Same as R4	
R16	Res, Fxd, Comp, 10000 ohms, <u>+5%</u> , 1/4 watt	RC07GF103J
R17	Same as R6	
R18	Res, Fxd, Comp, 10 ohms, <u>+5%</u> , 1/4 watt	RC07GF100J
R19	Same as R8	
R20	Res, Fxd, Comp, 47000 ohms, <u>+5%</u> , 1/4 watt	RC07GF473J
R21	Same as R1	
R22	Same as R3	
R23	Same as R2	
R24	Res, Fxd, Comp, 3300 ohms, <u>+5%</u> , 1/4 watt	RC07GF332J
R25	Same as R5	
R26	Same as R6	
R27	Same as R18	
R28	Same as R3	
R29	Res, Fxd, Comp, 5600 ohms, <u>+5%</u> , 1/4 watt	RC07GF562J

A4647

REF SYMBOL	DESCRIPTION	TMC PART NUMBER
R30	Res, Fxd, Comp, 6800 ohms, <u>+5%</u> , 1/4 watt	RC07GF682J
R31	Same as R6	
R32	Same as R8	
R33	Same as R29	
R34	Res, Fxd, Comp, 15000 ohms, <u>+5%</u> , 1/4 watt	RC07GF153J
R35	Same as R6	
R36	Same as R6	
R37	Res, Fxd, Comp, 270 ohms, <u>+5%</u> , 1/4 watt	RC07GF271J
R38	Res, Fxd, Comp, 56 ohms, <u>+5%</u> , 1/4 watt	RC07GF560J
R39	Res, Fxd, Comp, 68 ohms, <u>+5%</u> , 1/4 watt	RC07GF680J
R40	Same as R37	
R41	Same as R37	
R42	Same as R5	
R43	Same as R4	
R44	Same as R8	
R45	Same as R7	
R46	Same as R6	
R47	Same as R9	
R48	Same as R4	
R49	Same as R5	
R50	Same as R6	
R51	Same as R7	
R52	Same as R8	
R53	Same as R4	

A4647

REF SYMBOL	DESCRIPTION	TMC PART NUMBER
R54	Same as R16	
R55	Same as R6	
R56	Same as R18	
R57	Same as R8	
R58	Same as R20	
R63	Res, Fxd, Comp, 5600 ohms, <u>+5%</u> , 1/4 watt	RC07GF562J
R67	Same as R63	
R68	Res, Fxd, Comp, 1500 ohms, <u>+5%</u> , 1/4 watt	RC07GF152J
R69	Same as R38	
Z3	Mixer, Bal	NW163

RF OUTPUT A-4502

REF SYMBOL	DESCRIPTION	TMC PART NUMBER
C1	Capacitor, Fixed, Plastic: 0.82 uf, $\pm 5\%$, 60 WVDC	CN114R82-5J
C2	Capacitor, Fixed, Ceramic: 10,000 uuf, GMV, 500 WVDC	CC100-16
C3	Same as C2	
C4	Same as C1	
C5 Thru C17	Same as C2	
C18	Capacitor, Fixed, Mica: 620 uuf, $\pm 1\frac{1}{2}\%$, 500 WVDC 500 WVDC	CM111F621D5S
C19	Capacitor, Fixed, Electrolytic: 50 uf, -10+150% at 120 cps at 25 degrees C; 50 WVDC; polarized.	CE105-50-50
C20	Capacitor, Fixed, Mica, 2200 uuf, $\pm 2\%$, 500 WVDC	CM112F222G5S
C21 thru C30	Not used	
C31 thru C34	Same as C2	
C35	Capacitor, Fixed, Ceramic: 1,000 uuf, GMV, 500 WVDC	CC100-29
C36	Same as C2	
C37	Same as C35	
C38	Same as C2	
C39	Capacitor, Fixed, Mica, 1100 uuf, $\pm 1\frac{1}{2}\%$, 500 WVDC	CM112F112D5S
CR1	Semiconductor Device, Diode	IN4864
CR2	Semiconductor Device, Diode	IN100
CR3	Same as CR2	
L1	Coil, Radio Frequency: 120 uh, $\pm 10\%$, molded case.	CL240-120

RF OUTPUT A-4502

REF SYMBOL	DESCRIPTION	TMC PART NUMBER
L2 thru L6	Same as L1	
L7	Coil, Radio Frequency, 2.20 uh, ±20%, molded case	CL240-2R2
L8	Same as L1	
L9 thru L12	Not Used	
L13	Coil, Radio Frequency: fixed, 120 uh, ±10%, molded case	CL275-121
L14 thru L22	Same as L13	
L23	Coil, Radio Frequency: fixed, 212 uh, ±10%, molded case	CL275-2R2
Q1	Transistor 2N5070	
Q2	Transistor 2N3375	
Q3	Transistor 2N1296	
R1	Resistor, Variable, Composition: 10,000 ohms, ±30%, 0.5 watts	RV124-1-103
R2	Same as R1	
R3	Resistor, Fixed, Composition: 22 ohms, ±5%, ½ watt	RC20GF220J
R4	Resistor, Fixed, Composition: 2,000 ohms, ±30%, ½ watt	RV124-1-200
R5	Resistor, Fixed, Composition: 5600 ohms, ±5%, ½ watt	RC20GF562J
R6	Resistor, Fixed, Composition: 3300 ohms, 5%, ½ watt	RC20GF332J
R7	Resistor, Fixed, Composition: 1000 ohms, ±5%, 1 watt	RC32GF102J
R8	Same as R3	

RF OUTPUT A-4502

REF SYMBOL	DESCRIPTION	TMC PART NUMBER
R9	Resistor, Fixed, Composition: 1000 ohms, ±5%, ½ watt	RC20GF102J
R10	Not Used	
R11	Resistor, Fixed, Composition: 47 ohms, ±5%, ¼ watt	RC07GF470J
R12	Same as R9	
R13	Resistor, Fixed, Composition: 10 ohms, ±5%, ½ watt	RC20GF100J
R14	Same as R10	
R15	Resistor, Fixed, Composition: 2200 ohms, ±5%, ½ watt	RC20GF222J
R16	Not used	
R17	Same as R9	
R18	Resistor, Fixed, Composition: 220 ohms, ±5%, ½ watt	RC20GF221J
R19	Resistor, Fixed, Composition: 47000 ohms, ±5%, ½ watt	RC20GF473J
R20	Not used	
R21	Resistor, Fixed, Composition: 43,000 ohms, ±5%, ½ watt	RC20GF433J
T1	Transformer, Radio Frequency: fixed,	TZ220
T2	Transformer, Radio Frequency: fixed,	TZ219

REF SYMBOL	DESCRIPTION	TMC PART NUMBER
C301	Cap, Fxd, Cer, 100000 uuf, +80-20%, 300 WVDC	CC100-37
C302	Cap, Fxd, 100 mfd, 200 WVDC	CN112A-105-M2
C303	Cap, Fxd, Elec, 150 mfd, 75 WVDC	CE105-150-75
C304	Cap, Fxd, Mtlz, 47 mfd, \pm 5%, 400 WVDC	CN114R47-5J
C305 thru C309	Same as C301	
CR301	Scond, Dev, Dio	1N2484
CR302	Same as CR301	
J301	Conn, Recp, ML, 14 contacts, 20 AWG. (Male)	JJ242-5P
J302	Conn, Recp, RF, 48 ohms, 500 WVDC, male contact (one contact)	JJ211
J303	Conn, Recp, Fml, 12 double contacts	JJ319-6DPE
J304	Same as J303	
J305	Same as J302	
J306	Conn, Recp, Fml, 14 contacts, 20 awg (Female)	JJ242-5S
L301	Coil, RF, Fxd, 120 uh, 311 ma	CL275-121
P301	Conn, Pl, Fml, 5 contacts, (Female)	PL225-8S
R301	Res, Fxd, Comp, 47 ohms, \pm 5%, 1/2 watt	RC20GF470J
R302	Res, Fxd, WW-5W, 15 ohms, 577 ma	RW107-10
T301	XFMR, SD, 115/230 VAC, 50/60 Hz	TF0352
XA301 and XZ302	Soc, Elec, Tube, 1250 WVDC, 3 amps, 8 contacts	TS100-3
Z303	PC, BD B,	A-4513
Z304	PC, BD A,	A-4512

D

C

B

A

UNIT	CONTROL OR SWITCH	POSITION
PSP	HV LINE	OFF
PSP	TRANSMITTER PLATES	STANDBY REMOTE ✓
PSP	MAIN LINE	ON
RFE	MULIMETER	PA FIL (RED LINE)
RFE	DRIVER & PA BAND	OPERATING FREQ
RFE	REAR PANEL CW/SSB	CW
MCU	POWER	X10
MCU	METER	RES
MCU	TUNE OPERATE	TUNE
MMX	POWER/STANDBY	STANDBY
MMX	EXCITER ON/PTT	PTT
MMX	RF OUTPUT	MINIMUM
MMX	CARRIER	MINIMUM
MMX	USB-LSB/MIC/LINE	- 0 -
MMX	FREQUENCY SELECT	OPERATING FREQ
MMX	MODE	USB
MMX	POWER/STANDBY	POWER
MMX	EXCITER ON/PTT	EXCITER ON
MMX	METER	CAR

UNIT	CONTROL OR SWITCH	POSITION
MMX	CARRIER	'FULL'
MMX	METER	RF
PSP	HV LINE	ON
PSP	TRANSMITTER PLATES	ON
RFE	PA DRIVER	DR 3V
RFE	PA TUNING & LOADING	100W (MCU)
MCU	ADJUST RES AND REACT	FOR MAX FORWARD PWR & LOWEST VSWR
MCU	POWER	X1
MCU	CHECK ABOVE ADJ	
MCU	TUNE /OPERATE	OPERATE
MCU	POWER	X10
MMX	RF OUTPUT	INCREASE
RFE	PA /TUNING /LOADING	DIP - 300W
MCU	FORWARD POWER	300W
MCU	VSWR	LESS THEN 2:1
RFE	MULTIMETER	PA FIL = RED LINE
RFE	MULTIMETER	PA HV = 2.2KV
RFE	MULTIMETER	PA 1sg = -5 (RED)

QTY / UNIT	MODEL USED ON	ASS'Y NO.
APPLICATION		
CODE		

NOTICE TO PERSONS RECEIVING THIS DRAWING
 THE TECHNICAL MATERIEL CORPORATION claims proprietary right in the material disclosed hereon. This drawing is issued in confidence for engineering information only and may not be reproduced or used to manufacture anything shown hereon without permission from THE TECHNICAL MATERIEL CORPORATION to the user. This drawing is loaned for mutual assistance and is subject to recall at any time.

UNLESS OTHER DIMENSIONS AND INCLUDE CH OR PLATE

TOLERA

DECIMALS
 .X ± .05
 .XX ± .01
 .XXX ± .005

MATERIAL

FINISH

REVISIONS							
ZONE	LTR	DESCRIPTION	DATE	E.M.N.NO	DRAFT	CHKD	APPD
	0	ORIGINAL RELEASE FOR PRODUCTION	4/5/74			DV	

POSITION

'FULL'
RF
ON
ON
DR 3V
100W (MCU)
FOR MAX. FORWARD
PWR & LOWEST VSWR
X1

OPERATE
X10
INCREASE
DIP = 300MA
300W
LESS THEN 2:1
PA FIL = RED LINE
PA HV = 2.2KV
PA 1sg = -5 (RED)

UNIT	CONTROL OR SWITCH	POSITION
RFE	MULTIMETER	DR = 40-50
RFE	MULTIMETER	RF PL = .7KV
RFE	MULTIMETER	RF OUT = 120V
MMX	CARRIER	MINIMUM
	<u>FSK & CW MODE</u>	
RFE	REAR PANEL	CW
MCU	POWER METER	300W
	<u>USB OR LSB</u>	
RFE	REAR PANEL	SSB
RFE	PA PLATE METER	220 ma
MMX	MODE	USB OR LSB
MMX	USB-LSB/MIC/LINE	ADJUST LEVEL
RFE	PA PLATE METER	380 ma (VOICE PEAKS)
MCU	POWER METER	500W (VOICE PEAKS)

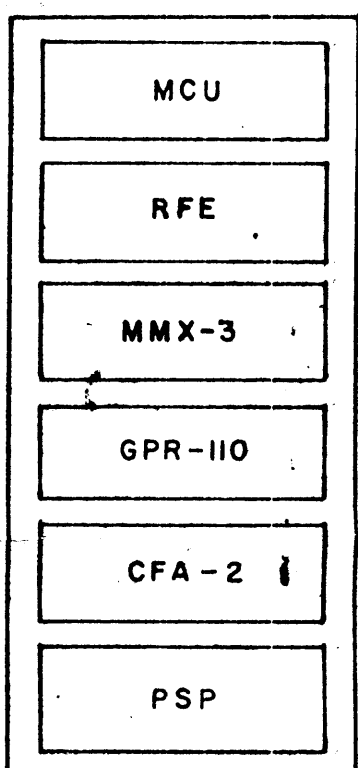

D

C

LD3021

B

A

QTY. REQ.	ITEM	PART NO.	DESCRIPTION	SYMBOL
LIST OF MATERIAL				
UNLESS OTHERWISE SPECIFIED DIMENSIONS ARE IN INCHES AND INCLUDE CHEMICALLY APPLIED OR PLATED FINISHES		FINAL APPROVAL <i>GAB</i>	DATE	THE TECHNICAL MATERIEL CORP. MAMARONECK, NEW YORK OPERATING INSTRUCTIONS SYM 5202
TOLERANCES ON		MECH. DES.	DATE	
DECIMALS	FRACTIONS	ELECT. DES.	DATE	
.X ± .05	± 1/64	CHECKED	DATE	
.XX ± .01	ANGLES	DRAWN <i>G de la...</i>	DATE 3-15-74	
XXX ± .005	± 0°-30'			
MATERIAL		SIZE	CODE IDENT. NO.	DWG NO.
FINISH		C	82679	LD 3021
SCALE			SHEET	OF

PC BD A POWER SUPPLY A-4512

REF SYMBOL	DESCRIPTION	TMC PART NUMBER
C1	Capacitor, Fixed, Electrolytic, 200 mfd, 50 WVDC	CE105-200-50
C2	Same as C1	
C3	Capacitor, Fixed, Electrolytic, 150 mfd, 75 WVDC	CE105-150-75
C4	Same as C3	
CR1	Rectifier, Semiconductor, Device	DD130-200-40

PC BD B POWER SUPPLY A-4513

REF SYMBOL	DESCRIPTION	TMC PART NUMBER
C1	Capacitor, Fixed Electrolytic, 25 mfd, +50-15%, 50 WVDC	CE107-6
C2	Same as C1	
C3	Same as C1	
C4	Same as C1	
C5	Same as C1	
CR1	Semiconductor, Device Diode	1N100
CR2	Same as CR1	
CR3	Semiconductor, Device, Diode	1N4619
CR4	Semiconductor, Device, Diode	1N753A
CR5	Same as CR3	
CR6	Semiconductor, Device, Diode	1N972B
CR7	Same as CR4	
Q1	Transistor 2N1481	
Q2	Same as Q1	
Q3	Same as Q1	
Q4	Transistor 2N3638	
Q5	Same as Q1	
Q6	Same as Q4	
Q7	Same as Q1	
R1	Resistor, Fixed, Composition, 470 ohms, ±5%, ¼ watt	RC07GF471J
R2	Resistor, Fixed, Composition, 1000 ohms, ±5%, ¼ watt	RC07GF102J
R3	Resistor, Variable, Composition, 1000 ohms, ±30%, ½ watt	RV124-1-102
R4	Same as R2	
R5	Same as R2	

PC BD B POWER SUPPLY A-4513

REF SYMBOL	DESCRIPTION	TMC PART NUMBER
R6	Resistor, Fixed, Composition, 10000 ohms, ±5%, ¼watt	
R7	Same as R2	
R8	Same as R3	
R9	Resistor, Fixed, Composition, 4700 ohms, ±5%, ¼watt	RC07GF472J
R10	Resistor, Fixed, Composition, 1500 ohms, ±5%, ¼watt	RC07GF152J
R11	Resistor, Fixed, Wirewound, 1 ohms, ±2%, 5 watt	RR114-10W2
R12	Same as R3	
R13	Resistor, Fixed, Composition, 6800 ohms, ±5%, ¼watt	RC07GF682J
R14	Same as R2	
R15	Same as R11	
R16	Resistor, Fixed, Composition, 4700 ohms, ±5%, ¼watt	RC07GF472J
R17	Resistor, Fixed, Composition, 150 ohms, ±5%, ¼watt	RC07GF151J
R18	Resistor, Variable, Composition, 10000 ohms, ±30%, ½ watt	RV124-1-103
R19	Same as R17	

REF SYMBOL	DESCRIPTION	TMC PART NUMBER
C1	Cap, Disc, Cer, 100000 uuf, +80-20%, 25 WVDC	CC100-44
C2	Cap, Fxd, Mica, 22 uuf, <u>+5%</u> , 500 WVDC	CM11C220J5
C3	Cap, Disc, Cer, 10000 uuf, <u>+20%</u> , 50 WVDC	CC100-42
C4	Cap, Elec, 10 mfd, +75-15%, 15 WVDC	CE122-10-15
C5	Same as C3	
C6	Same as C4	
C7	Cap, Fxd, Elec, 5 mfd, 25 WVDC	CE122-5-25
C8	Same as C3	
C9	Same as C4	
C10	Same as C7	
C11	Same as C4	
C12	Cap, Fxd, Elec, 22 mfd, 16 WVDC	CE122-22-16
C13 thru C14	Same as C7	
C17	Same as C1	
C18	Same as C12	
C21 and C22	Same as C1	
C23	Same as C1	
C24	Same as C3	
C25 thru C27	Same as C1	
C28	Cap, Fxd, Mica, 3800 uuf, <u>+2%</u> , 300 WVDC	CM112F382G3

REF SYMBOL	DESCRIPTION	TMC PART NUMBER
C29 thru C32	Same as C1	
C33	Same as C28	
C34 thru C36	Same as C1	
C37	Cap, Var, Cer, 9-35 uuf, 100 WVDC	CV112-2
C38	Same as C7	
C39	Same as C7	
C40	Same as C1	
C41	Cap, Disc, Cer, 100000 uuf, +80-20%, 100 WVDC	CC100-28
C42	Same as C41	
C43	Same as C1	
C44	Same as C1	
C45	Same as C12	
C46 thru C48	Same as C1	
C49	Same as C41	
C50	Same as C1	
C51	Same as C1	
C52	Same as C3	
C53 and C54	Same as C41	
C55 and C56	Same as C1	

A4707

REF SYMBOL	DESCRIPTION	TMC PART NUMBER
C57	Same as C41	
C58	Same as C1	
C59	Same as C41	
C60	Same as C41	
C61	Same as C7	
C62	Same as C7	
C63 and C64	Same as C12	
C65	Same as C7	
C66	Same as C12	
C67	Cap, Fxd, Mica, 300 uuf, <u>+5%</u> , 500 WVDC	CM111F301J5
C68 and C69	Same as C7	
C70	Same as C4	
C71	Same as C4	
C72	Same as C7	
C74	Same as C7	
C75	Same as C7	
C76	Same as C12	
C80	Same as C7	
C81	Same as C7	
CR1	Diode, Silicon	1N914
CR2	Same as CR1	
CR3	Same as CR1	
CR4	Diode, Ref, Silicon	1N961

REF SYMBOL	DESCRIPTION	TMC PART NUMBER
CR5 and CR6	Diode, Silicon	1N914
CR7	Diode,	1N712
K1	Relay, Armature, Min	RL143-4
L1 thru L3	Coil, 1000 ohms, <u>+10%</u> ,	CL275-102
L5 thru L10	Same as L1	
L12 thru L17	Same as L1	
Q1 thru Q7	Transistor, Silicon	2N3646
Q8	Transistor, GE	2N1225
Q9 and Q10	Transistor, Silicon	2N863
Q11	Same as Q8	
Q12	Same as Q8	
Q13	Same as Q9	
Q14 thru Q16	Same as Q9	
Q17 and Q18	Same as Q1	
Q19	Same as Q8	
Q20	Same as Q1	

A4707

REF SYMBOL	DESCRIPTION	TMC PART NUMBER
Q21 thru Q26	Same as Q1	
Q27	Transistor	2N696
Q28	Same as Q1	
Q29	Same as Q1	
R1	Res, Fxd, Comp, 1200 ohms, <u>+5%</u> , 1/4 watt	RC07GF122J
R2	Res, Fxd, Comp, 47000 ohms, <u>+5%</u> , 1/4 watt	RC07GF473J
R3	Res, Fxd, Comp, 10000 ohms, <u>+5%</u> , 1/4 watt	RC07GF103J
R4	Res, Fxd, Comp, 56000 ohms, <u>+5%</u> , 1/4 watt	RC07GF563J
R5	Res, Fxd, Comp, 100000 ohms, <u>+5%</u> , 1/4 watt	RC07GF104J
R6	Same as R4	
R7	Res, Fxd, Comp, 470000 ohms, <u>+5%</u> , 1/4 watt	RC07GF474J
R8	Res, Var, 5000 ohms, <u>+5%</u>	RV124-502
R9	Same as R3	
R10	Res, Fxd, Comp, 22000 ohms, <u>+5%</u> , 1/4 watt	RC07GF223J
R11	Res, Fxd, Comp, 1500 ohms, <u>+5%</u> , 1/4 watt	RC07GF152J
R12	Res, Fxd, Comp, 100 ohms, <u>+5%</u> , 1/4 watt	RC07GF101J
R13	Res, Fxd, Comp, 470 ohms, <u>+5%</u> , 1/4 watt	RC07GF471J
R14	Same as R10	
R15	Same as R3	
R16	Same as R13	
R17	Same as R12	
R18	Same as R11	
R19	Same as R2	

REF SYMBOL	DESCRIPTION	TMC PART NUMBER
R20	Same as R77	
R21	Res, Fxd, Comp, 1000 ohms, <u>+5%</u> , 1/4 watt	RC07GF102J
R22	Res, Fxd, Comp, 5600 ohms, <u>+5%</u> , 1/4 watt	RC07GF562J
R23	Same as R22	
R24	Res, Fxd, Comp, 270 ohms, <u>+5%</u> , 1/4 watt	RC07GF271J
R25	Res, Fxd, Comp, 47 ohms, <u>+5%</u> , 1/4 watt	RC07GF470J
R26	Res, Fxd, Comp, 330 ohms, <u>+5%</u> , 1/4 watt	RC07GF331J
R27	Same as R21	
R28	Same as R21	
R29	Res, Fxd, Comp, 22 ohms, <u>+5%</u> , 1/4 watt	RC07GF220J
R30	Res, Fxd, Comp, 3300 ohms, <u>+5%</u> , 1/4 watt	RC07GF332J
R31	Same as R24	
R32	Same as R24	
R33	Same as R30	
R34	Same as R29	
R35	Same as R21	
R36	Same as R26	
R37	Same as R3	
R38	Same as R3	
R39	Same as R21	
R40	Res, Fxd, Comp, 8200 ohms, <u>+5%</u> , 1/4 watt	RC07GF822J
R41	Same as R12	
R42	Same as R30	
R43	Same as R25	

A4707

REF SYMBOL	DESCRIPTION	TMC PART NUMBER
R44	Same as R5	
R45	Res, Fxd, Comp, 330000 ohms, <u>+5%</u> , 1/4 watt	RC07GF334J
R46	Same as R23	
R47	Same as R12	
R48	Res, Fxd, Comp, 6800 ohms, <u>+5%</u> , 1/4 watt	RC07GF682J
R49	Same as R3	
R50	Same as R48	
R51	Same as R21	
R52	Res, Fxd, Comp, 4700 ohms, <u>+5%</u> , 1/4 watt	RC07GF472J
R53	Same as R8	
R54	Same as R25	
R55	Same as R52	
R56	Same as R8	
R57	Res, Fxd, Comp, 2200 ohms, <u>+5%</u> , 1/4 watt	RC07GF222J
R58	Same as R12	
R59	Same as R25	
R60	Same as R13	
R61	Res, Fxd, Comp, 150000 ohms, <u>+5%</u> , 1/4 watt	RC07GF154J
R62	Same as R57	
R63	Same as R3	
R64	Res, Fxd, Comp, 180 ohms, <u>+5%</u> , 1/4 watt	RC07GF181J
R65	Same as R29	
R66	Same as R21	
R67	Same as R57	

A4707

REF SYMBOL	DESCRIPTION	TMC PART NUMBER
R68	Same as R57	
R69	Same as R22	
R70	Same as R1	
R71	Same as R11	
R72	Same as R21	
R73	Same as R22	
R74	Same as R10	
R75	Same as R40	
R76	Same as R12	
R77	Res, Fxd, Comp, 15000 ohms, <u>+5%</u> , 1/4 watt	RC07GF153J
R78	Res, Fxd, Comp, 3900 ohms, <u>+5%</u> , 1/4 watt	RC07GF392J
R79	Same as R21	
R80	Same as R12	
R81	Same as R13	
R82	Same as R22	
R83	Same as R22	
R84	Same as R21	
R85	Same as R24	
R86	Same as R13	
R87	Res, Fxd, Comp. 220000 ohms, <u>+5%</u> , 1/4 watt	RC07GF224J
R88	Same as R57	
R89	Same as R78	

A4707

REF SYMBOL	DESCRIPTION	TMC PART NUMBER
R90	Same as R77	
R91	Same as R21	
R92	Same as R12	
R93	Same as R21	
T1	Transformer, Audio, Matching	TF359
T2	Transformer, RF, Tuned	TT285-11
T3	Same as T2	
T4	Transformer, RF Tuned	TT286-7
Y1	Crystal, Quartz	CR109-147
Z1	BAL. MOD.	NW163
FL1*	Filter, Bandpass; 250 kHz, Upper Sideband	FX195-4
	Filter, Bandpass; 250 kHz, Lower Sideband	FX195-5
<p>* - Particular filter supplied depends upon option specified. A4707 plus FX195-4 becomes A4707-1, which is the Upper Sideband option; A4707 plus FX195-5 becomes A4707-2, or the Lower Sideband option. When ISB option is specified, two A4707 boards are supplied: one containing FX195-4, and the other containing FX195-5, thus providing both A4707-1 and A4707-2, to permit operation on either or both sidebands independently and simultaneously.</p>		

A4718

REF SYMBOL	DESCRIPTION	TMC PART NUMBER
C1	Cap, Fxd, Elec, 125 ufd, 15 WVDC	CE105-125-15
C2	Cap, Fxd, Elec, 10 ufd, 25 WVDC	CE105-10-25
C3	Cap, Fxd, Cer, 100000 PF, +80-20%, 25 WVDC	CC100-44
C4	Cap, Fxd, Elec, 25 ufd, 25 WVDC	CE105 25-25
C5	Cap, Fxd, Cer, 10,000 uuf, +80-20%	CC100-41
C6	Cap, Fxd, Elec, 10 ufd, 25 WVDC	CE105-10-25
C7	Cap, Fxd, Elec, 40 ufd, 25 WVDC	CE105-40-15
C8	Same as C3	
C9	Cap, Fxd, Elec, 100 ufd, 15 WVDC	CE105-100-15
C10	Cap, Fxd, Mica, 3900 PF, <u>+1%</u> , 300 WVDC	CM112F392G3
C11	Same as C3	
C12	Cap, Fxd, Cer, 200000 uuf, +80-20%, 25 WVDC	CC100-33
L1	Coil RF, 330 uh, <u>+10%</u> , 215 ma.	CL275-331
L2	Coil RF, 220 uh, <u>+10%</u> , 250 ma.	CL275-221
L3	coil RF, 1000 uh, <u>+10%</u> , 135 ma.	CL275-102
R1	Res, Fxd, Comp, 3300 ohms, <u>+ 5%</u> , 1/4 watt	RC07GF332J
R2	Res, Fxd, Comp, 10000 ohms, <u>+ 5%</u> , 1/4 watt	RC07GF103J
R3	Res, Fxd, Comp, 1500 ohms, <u>+ 5%</u> , 1/4 watt	RC07GF152J
R4	Res, Fxd, Comp, 18 ohms, <u>+ 5%</u> , 1/4 watt	RC07GF180J
R5	Res, Fxd, Comp, 470 ohms, <u>+ 5%</u> , 1/4 watt	RC07GF471J
R6	Res, Fxd, Comp, 270 ohms, <u>+ 5%</u> , 1/4 watt	RC07GF271J
R7	Res, Fxd, Comp, 1000 ohms, <u>+ 5%</u> , 1/4 watt	RC07GF102J
R8	Same as R5	
R9	Same as R2	

A4718

REF SYMBOL	DESCRIPTION	TMC PART NUMBER
R10	Res, Fxd, Comp, 47000 ohms, <u>+5%</u> , 1/4 watt	RC07GF473J
R11	Res, Fxd, Comp, 100 ohms, <u>+5%</u> , 1/4 watt	RC07GF101J
R12	Same as R5	
R13	Cap, Fxd, Comp, 47 ohms, <u>+ 5%</u> , 1/4 watt	RC07GF470J
R14	Same as R5	
R15	Res, Var, Comp, 100 ohms, <u>+ 30</u> , 1/2 watt	RV124-1-101
T1	Transformer RF Tuned	TT285-15
Q1	Transistor,	2N3646
Q2	Same as Q1	
Q3	Same as Q1	

REF SYMBOL	DESCRIPTION	TMC PART NUMBER
C1 thru C4	Cap, Disk, Cer, 10000 uuf, +80%-20%	CC100-41
C5	Cap, Disk, Cer, 20000 uuf, +80%-20%, 25 WVDC	CC100-40
C6	Same as C1	
C7	Cap, Mica, Fxd, 5 uuf, <u>±</u> 10%, 500 WVDC	CM111C050K5S
C8	Same as C5	
C9	Same as C1	
C10	Same as C1	
C11	Cap, Disk, Cer, 200000 uuf, +80%-20%, 25 WVDC	CC100-33
C12	Cap, Mica, Fxd, 330 uuf, <u>±</u> 2%, 500 WVDC	CM111F331G5
C13	Cap, Disk, Cer, 1000 uuf, +80%-20%,	CC100-29
C14	Same as C13	
C15	Cap, Mica, Fxd, 100000 uuf, +80%-20%, 25 WVDC	CC100-44
C16	Same as C13	
CR1	Semiconductor, Diode	1N914
CR2	Same as CR1	
CR3	Semiconductor, Diode, Silicon	1N34A
CR4 thru CR6	Same as CR3	
CR7 and CR8	Semiconductor, Diode, Silicon	1N755A
CR9 thru CR13	Semiconductor, Diode, Silicon	1N627
CR14	Semiconductor, Diode, Silicon	1N752A

A4683

REF SYMBOL	DESCRIPTION	TMC PART NUMBER
L1	Coil, 1000 UH, <u>+10%</u> , 135 MA	CL275-102
L2	Coil, 220 UH, <u>+10%</u> , 250 MA	CL275-221
Q1 and Q2	Transistor, Silicon	2N3646
Q3	Transistor, Silicon	2N1711
Q4 thru Q8	Transistor, Silicon	2N696
Q9	Same as Q3	
R1 and R2	Res, Fxd, Comp, 2200 ohms, <u>+5%</u> , 1/4 watt	RC07GF222J
R3	Res, Fxd, Comp, 470 ohms, <u>+5%</u> , 1/4 watt	RC07GF471J
R4	Res, Fxd, Comp, 1500 ohms, <u>+5%</u> , 1/4 watt	RC07GF152J
R5	Res, Fxd, Comp, 1000 ohms, <u>+5%</u> , 1/4 watt	RC07GF102J
R6	Res, Fxd, Comp, 10000 ohms, <u>+5%</u> , 1/4 watt	RC07GF103J
R7	Same as R1	
R8	Same as R5	
R9	Res, Fxd, Comp, 4700 ohms, <u>+5%</u> , 1/4 watt	RC07GF472J
R10	Res, Fxd, Comp, 22000 ohms, <u>+5%</u> , 1/4 watt	RC07GF223J
R11	Same as R6	
R12	Same as R10	
R13	Same as R10	
R14	Same as R3	
R15	Same as R9	
R16	Res, Var, 1000 ohms, <u>+30%</u>	RV124-1-102

A4683

REF SYMBOL	DESCRIPTION	TMC PART NUMBER
R17 thru R20	Res, Fxd, Comp, 47000 ohms, <u>+5%</u> , 1/4 watt	RC07GF473J
R21	Res, Fxd, Comp, 6800 ohms, <u>+5%</u> , 1/4 watt	RC07GF682J
R22	Res, Var, 1000 ohms, <u>+5%</u> , standard	RV119-3-102
R23	Res, Var, 10000 ohms, <u>+5%</u> ,	RV119-3-103
R24	Same as R17	
R25	Same as R23	
R26	Same as R6	
R27	Res, Fxd, Comp, 220 ohms, <u>+5%</u> , 1/4 watt	RC07GF221J
R28	Same as R22	
R29	Same as R23	
R30	Same as R6	
R31	Res, Fxd, Comp, 100000 ohms, <u>+5%</u> , 1/4 watt	RC07GF104J
R32	Same as R6	
R33	Res, Fxd, Comp, 330 ohms, <u>+5%</u> , 1/4 watt	RC07GF331J
R34	Same as R5	
T1	Transformer, 795 KHz, "Q" 710, "L" <u>+20%</u> , 250 UH	TZ216
T2	Transformer, 795 Kc/S, "Q" 710, "L" <u>+20%</u> , 250 UH	TZ218
Z1	Network Int., Ckt., 3.0 WVDC, <u>+10%</u>	NW137
TP1	Term, Stud.	TEO 127-2
TP2	Same as TP1	

SECTION 7
SCHEMATIC DIAGRAMS

This section contains schematic diagrams for the SME-6. Table 7-1 lists the figure numbers contained herein and the corresponding TMC schematic drawing numbers.

TABLE 7-1. LIST OF DIAGRAMS

Figure No.	Title	TMC Dwg. No.
7-1	SME-6, Interconnection Diagram	CK1490
7-2	Carrier Generator Z104, Schematic Diagram	CK1486
7-3	Sideband Generator Z105 and Z109, Schematic Diagram	CK1481
7-4	AM Amplifier Z108, Schematic Diagram	CK1497
7-5	Frequency Shift Generator Z107, Schematic Diagram	CK1484
7-6	Converter and ALDC Z103, Schematic Diagram	CK1495
7-7	RF Amplifier Z101, Z102, Z111, Z112 and Z113, Schematic Diagram	CK1485
7-8	RF Output Z115, Schematic Diagram	CK1327
7-9	Power Supply Assembly, Interconnection Diagram	CK1328
7-10	Rectifier-Filter Z304, Schematic Diagram	CK1491
7-11	Regulator Z303, Schematic Diagram	CK1291

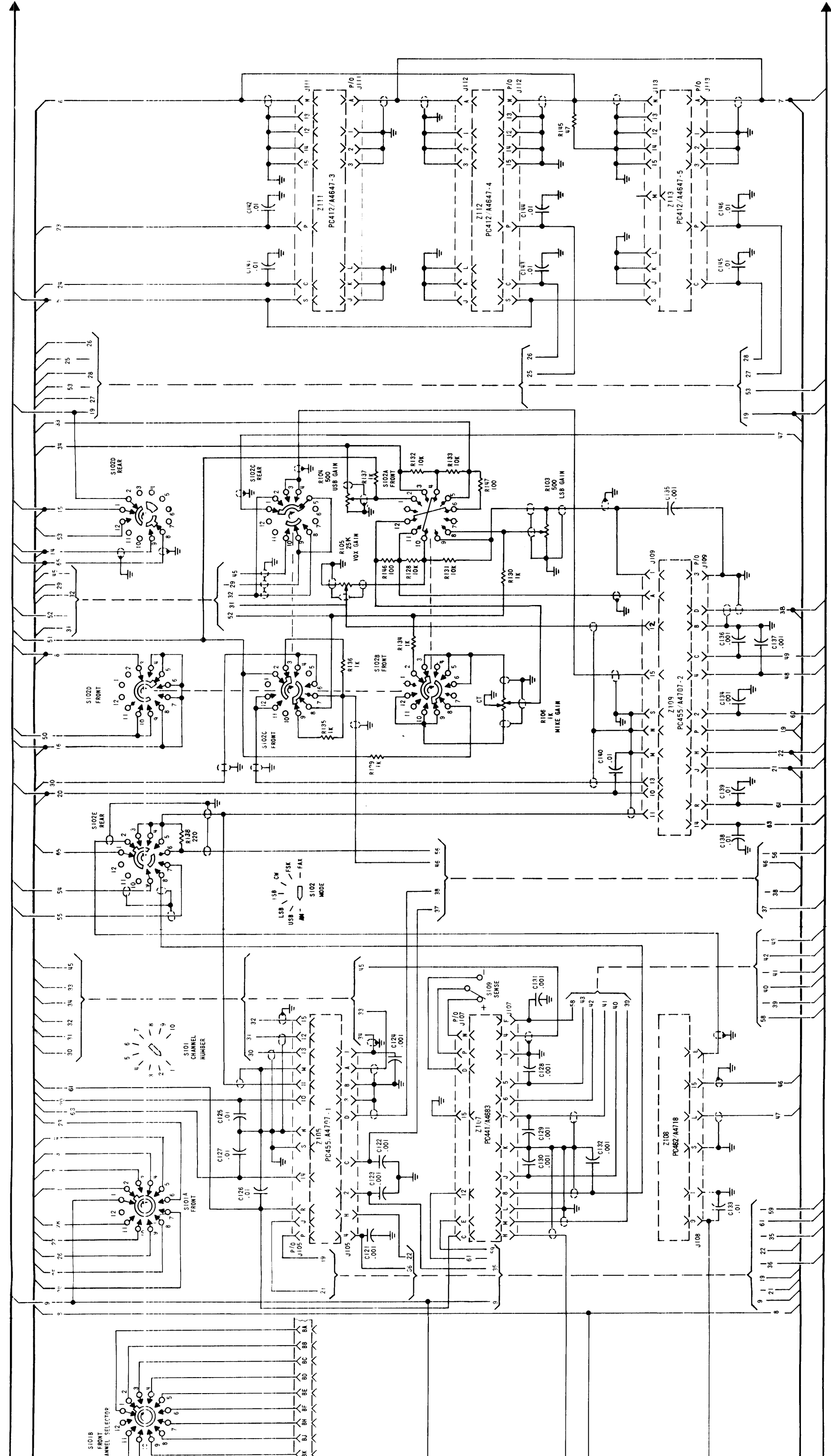
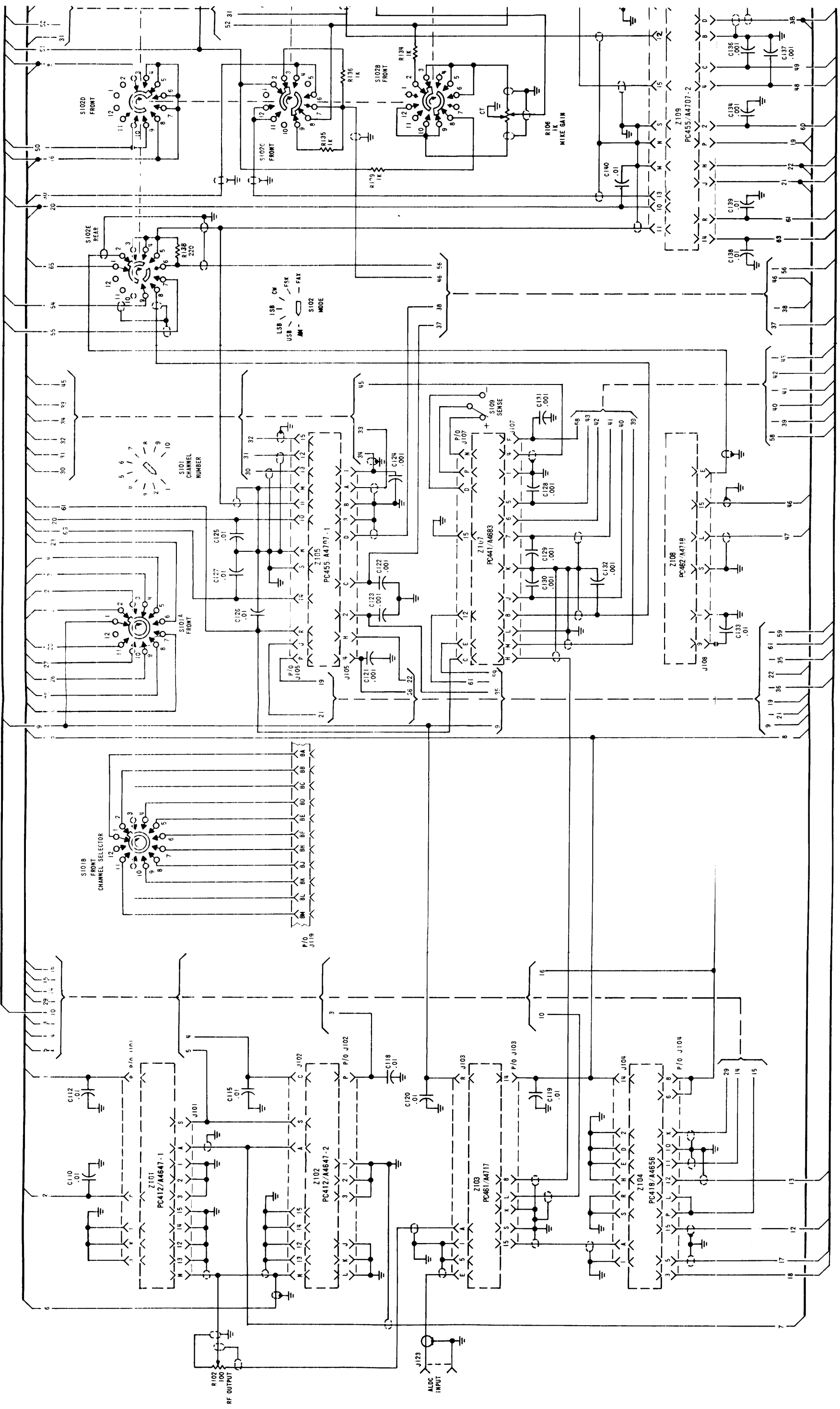
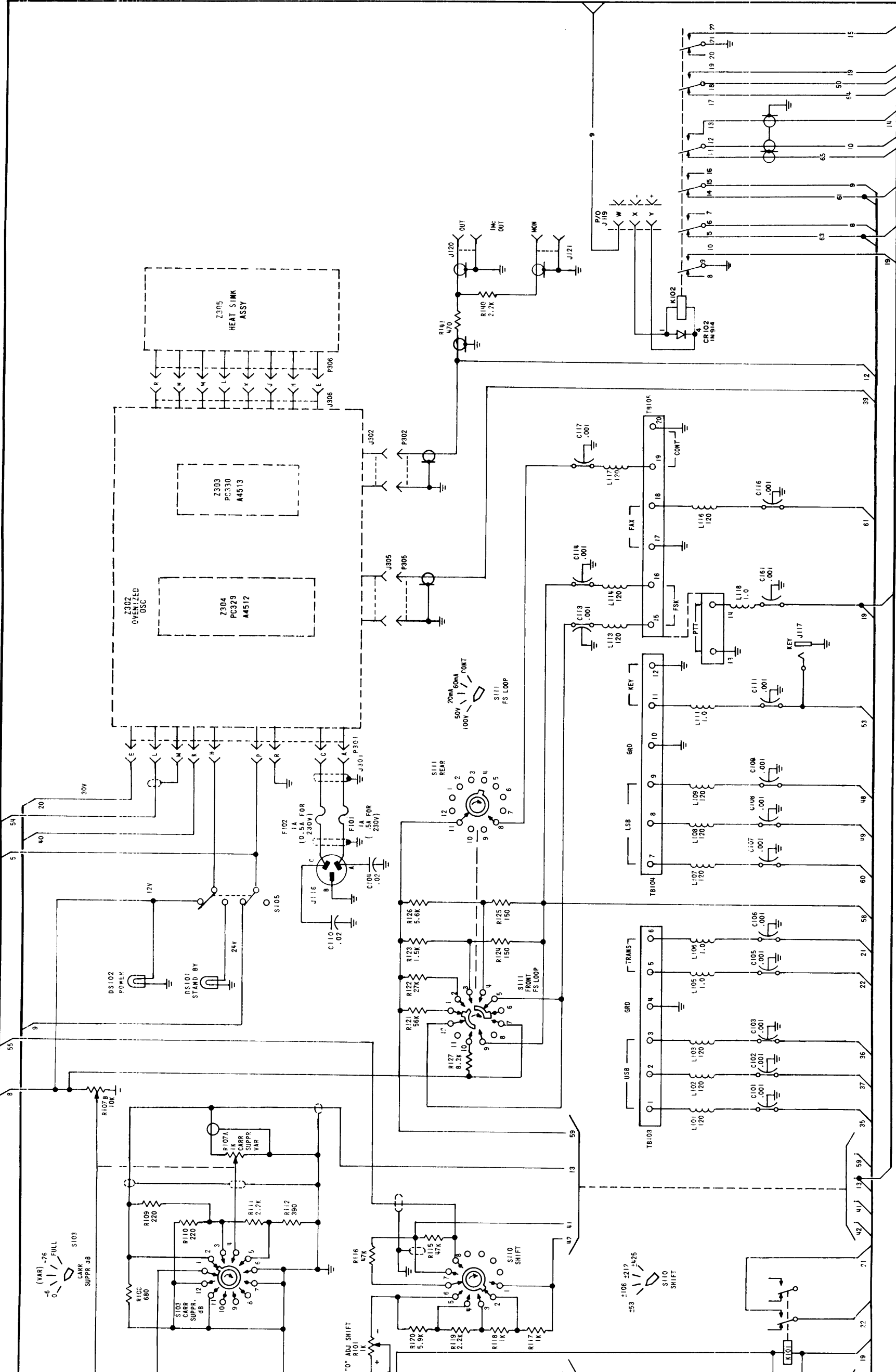

Figure 7-1. SME-6. Interconnection Diagram (Sheet 1 of 2)

005692045





100 SERIES	
LAST SYMBOLS	MISSING SYMBOLS
C161	
DS102	
F102	J106, J110, J122
J125	L110, L112, L115
L118	
M101	
R145	S107, S108
S111	TB101, TB102
TB105	Z106, Z110
Z115	
K102	
CR102	

300 SERIES	
LAST SYMBOLS	MISSING SYMBOLS
P306	P303, P304

UNLESS OTHERWISE SPECIFIED:
 1. ALL RESISTORS ARE IN OHMS.
 2. ALL CAPACITOR VALUES ARE IN MICROFARADS.
 3. ALL INDUCTANCE VALUES ARE IN MICROHENRIES.

BREAKOUT	
LAST NUMBER	MISSING NUMBER
65	11, 44, 57

Figure 7-1. SME-6, Interconnection Diagram (Sheet 2 of 2)

005692045

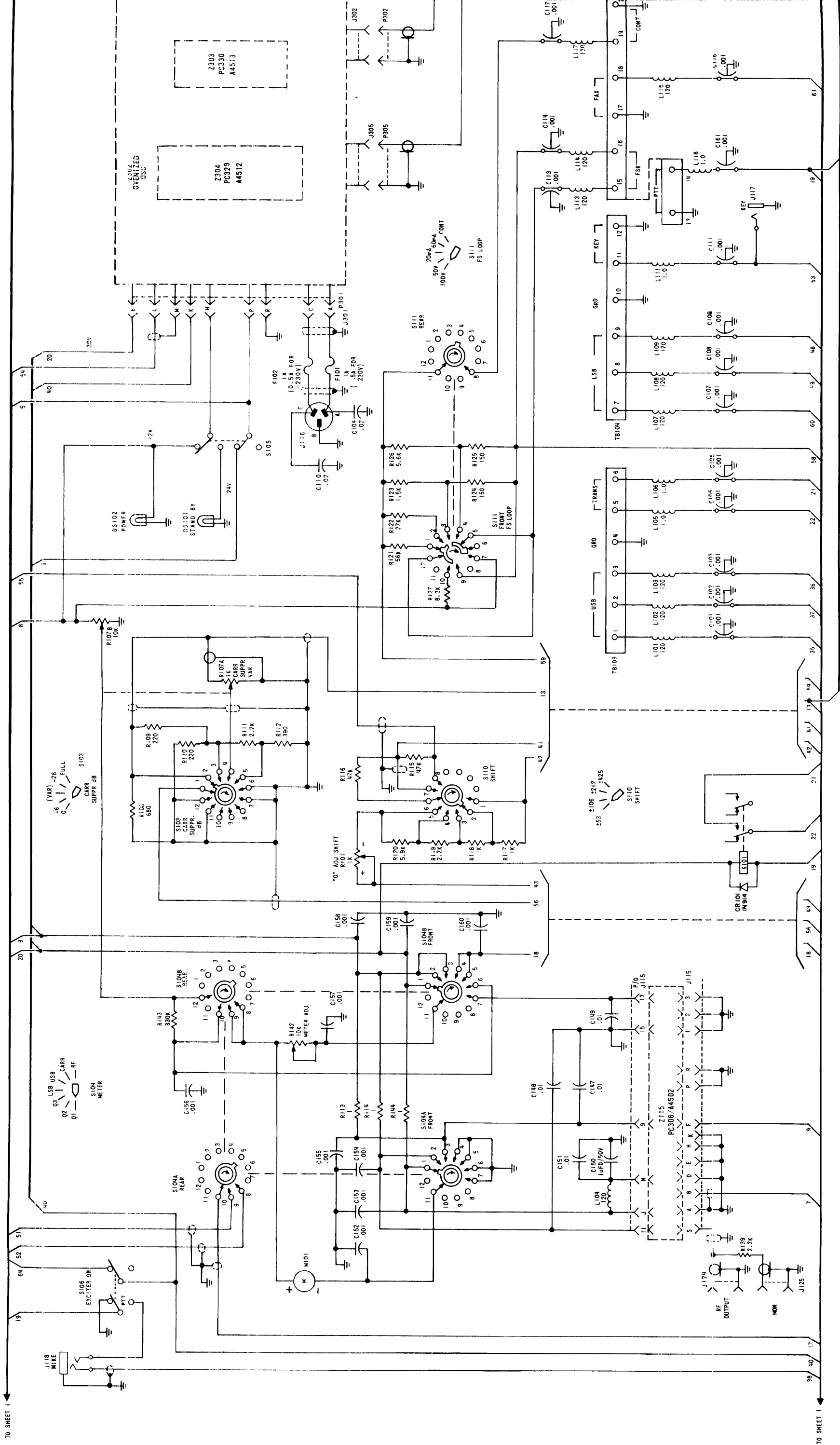

TO SHEET 1

TO SHEET 1

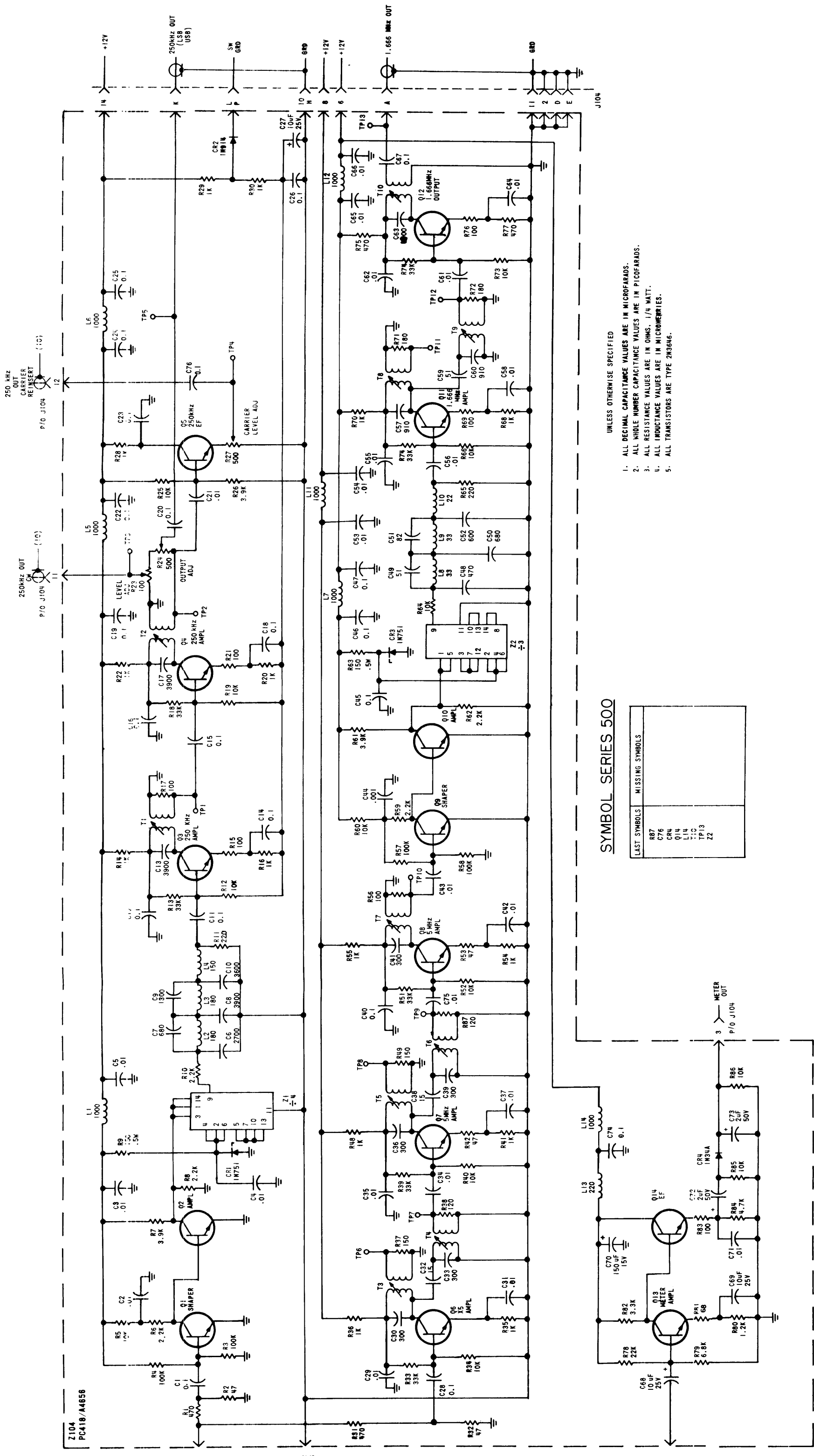

- UNLESS OTHERWISE SPECIFIED
1. ALL DECIMAL CAPACITANCE VALUES ARE IN MICROFARADS.
 2. ALL WHOLE NUMBER CAPACITANCE VALUES ARE IN PICOFARADS.
 3. ALL RESISTANCE VALUES ARE IN OHMS, 1/4 WATT.
 4. ALL IMPEDANCE VALUES ARE IN MICROMHMS.
 5. ALL TRANSISTORS ARE TYPE 2N3636G.

SYMBOL SERIES 500

LAST SYMBOLS	MISSING SYMBOLS
R87	
C76	
CR4	
Q14	
L14	
T10	
TP13	
Z2	

Figure 7-2. Carrier Generator Z104, Schematic Diagram

005692045

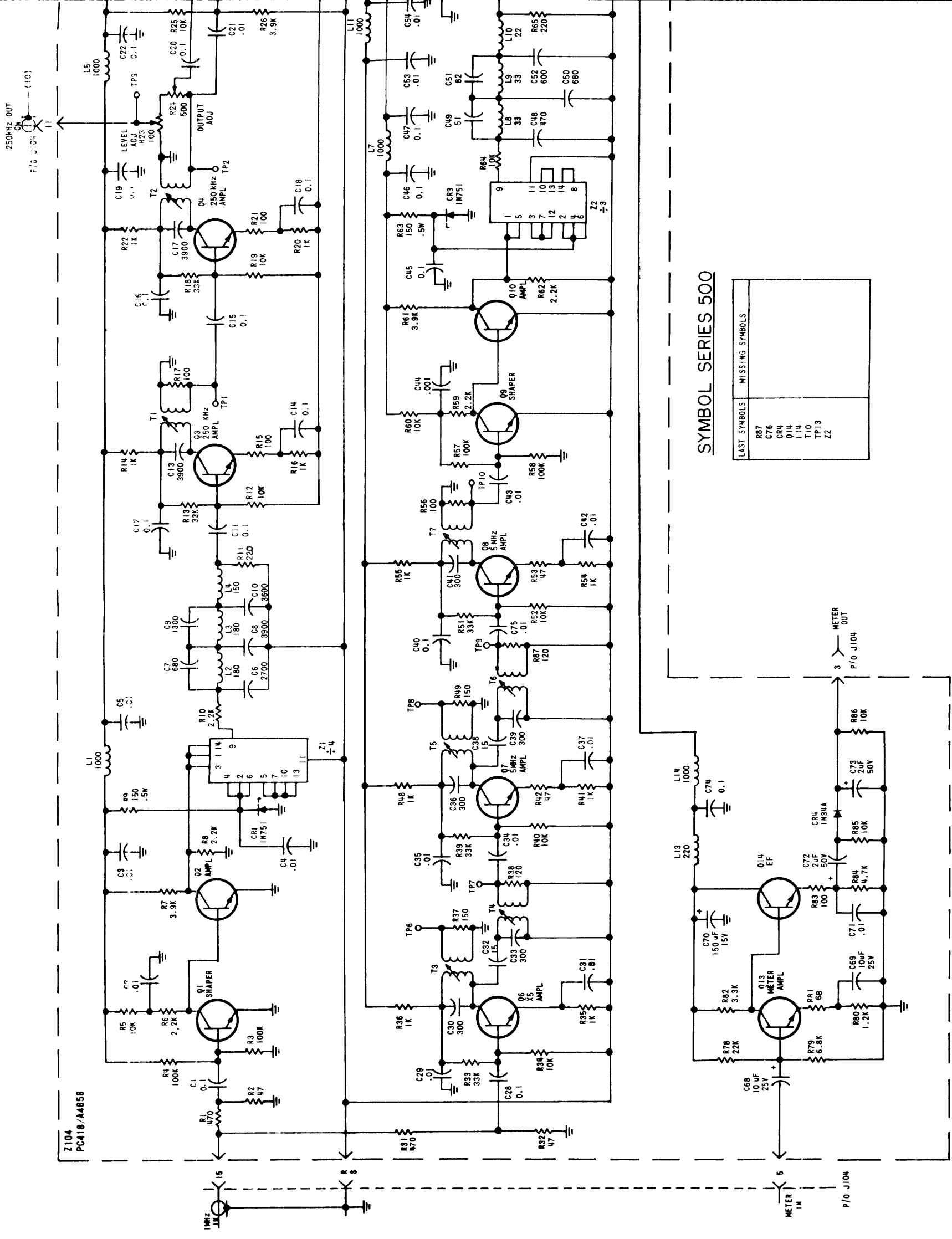

Z104
PC419/A4656

SYMBOL SERIES 500

LAST SYMBOLS	MISSING SYMBOLS
R87	
C76	
CR4	
Q14	
L14	
T10	
TP13	
Z2	

Figure 7-2. Carrier

005692045

PART NO.	Z 2	ASSEMBLY	SYMBOL	SERIES	DESCRIPTION
CK1481-1	FX195-4	A4507-1	Z105	800	UPPER SIDE BAND
CK1481-2	FX195-5	A4507-2	Z109	1100	LOWER SIDE BAND

SYMBOL SERIES (SEE TABLE)

LAST SYMBOLS	MISSING SYMBOLS
C81 CR7 K1 L17 Q29 R95 T4 Y1 Z2	C16,19,20, .78,79 L4, L11 R52,36

UNLESS OTHERWISE SPECIFIED
 1- ALL RESISTANCE VALUES ARE IN OHMS, 1/4 WATT.
 2- ALL CAPACITANCE VALUES ARE IN MICROFARADS.
 3- ALL INDUCTANCE VALUES ARE IN MICROHENRIES.

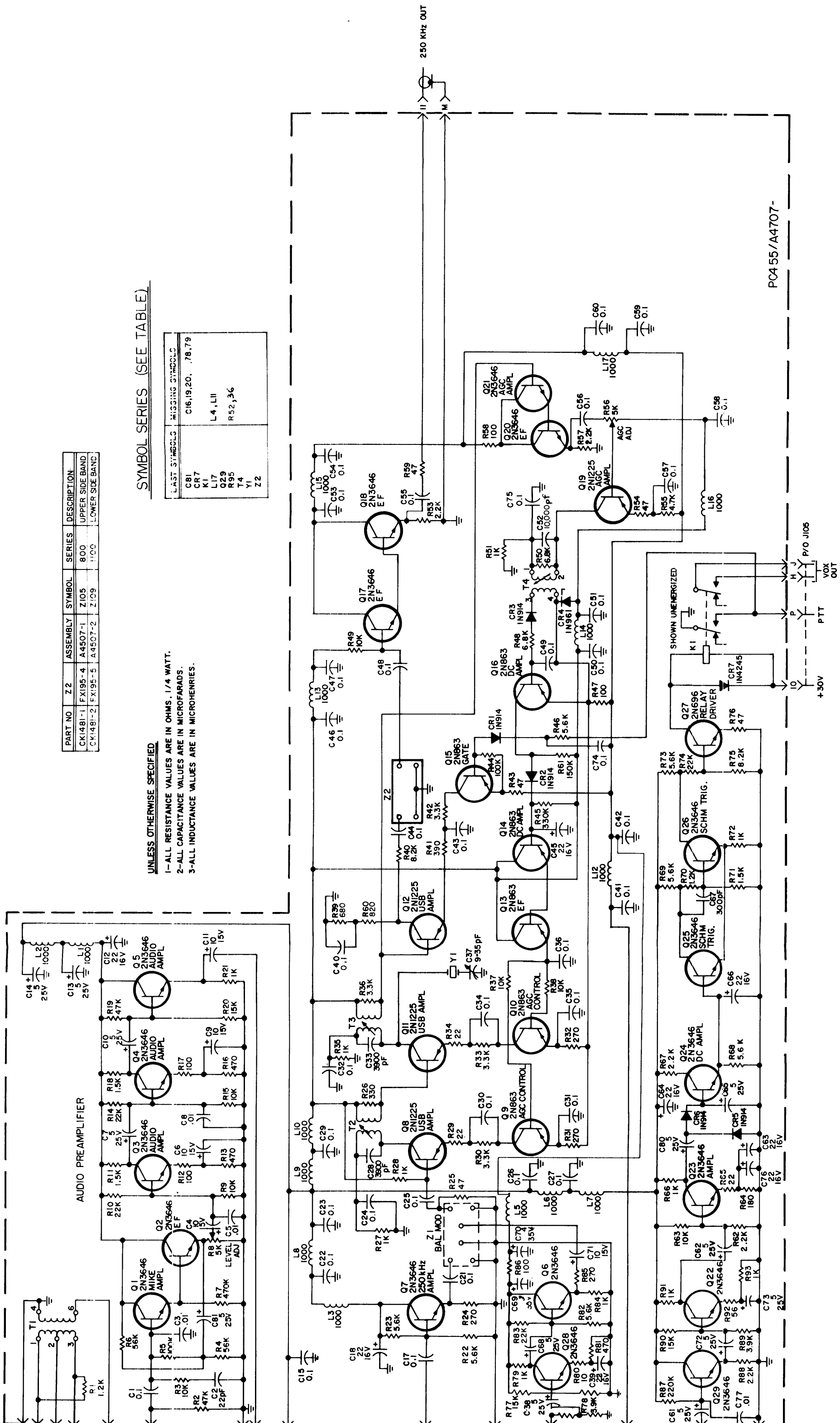

PC455/A4707-

Figure 7-3. Sideband Generator Z105 and Z109, Schematic Diagram

005692045

PART NO	Z2	ASSEMBLY SYMBOL	SERIES	DESCRIPTION
CK1481-1	FX195-4	A4507-1	800	UPPER SIDE BAND
CK1481-2	FX195-5	A4507-2	1100	LOWER SIDE BAND

SYMBOL

LAST SYMBOL	
CB1	
CR7	
K1	
L17	
Q29	
R95	
T4	
Y1	
Z2	

UNLESS OTHERWISE SPECIFIED
 1- ALL RESISTANCE VALUES ARE IN OHMS, 1/4 WATT.
 2- ALL CAPACITANCE VALUES ARE IN MICROFARADS.
 3- ALL INDUCTANCE VALUES ARE IN MICROHENRIES.

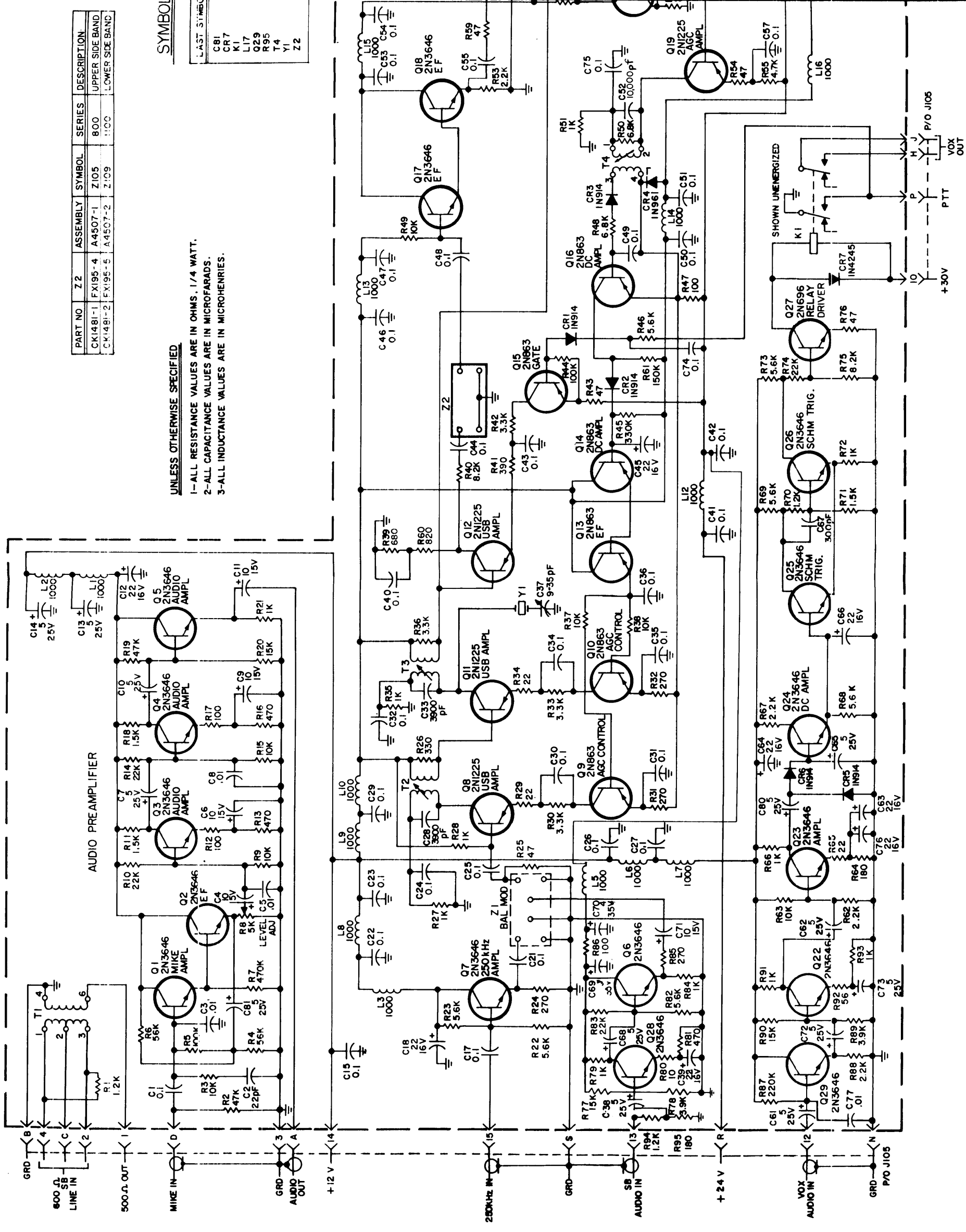
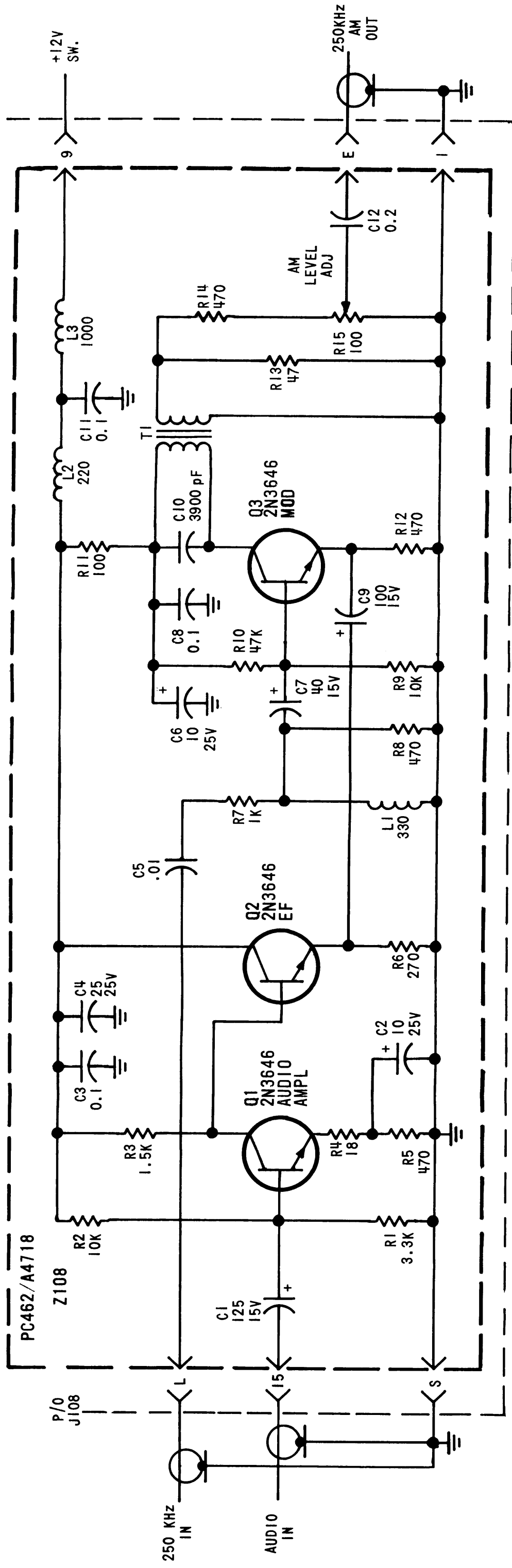

Figure 7-3. Sideband Generator

005692045

LAST SYMBOLS	MISSING SYMBOLS
C12	
L3	
Q3	
R15	
T1	



UNLESS OTHERWISE SPECIFIED:

1. ALL RESISTANCE VALUES ARE IN OHMS, 1/4W.
2. ALL CAPACITANCE VALUES ARE IN MICROFARADS.
3. ALL INDUCTANCE VALUES ARE IN MICROHENRIES.

Figure 7-4. AM Amplifier Z108, Schematic Diagram

005692045

7-11/7-12

LAST SYMBOLS	MISSING SYMBOLS
C12	
L3	
Q3	
R15	
T1	

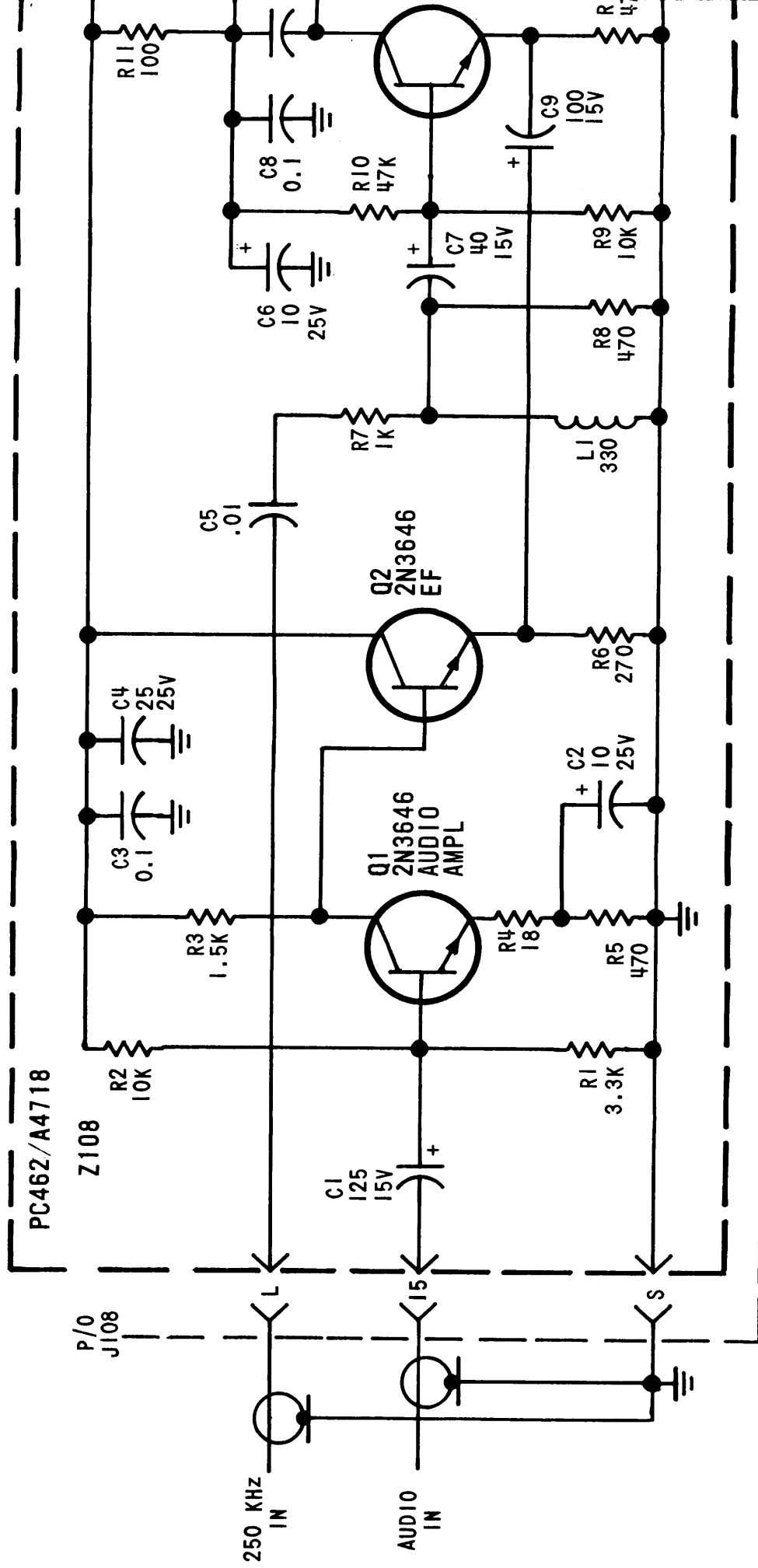

UNLESS OTHERWISE SPECIFIED:

1. ALL RESISTANCE VALUES ARE IN OHMS, 1/4W.
2. ALL CAPACITANCE VALUES ARE IN MICROFARADS.
3. ALL INDUCTANCE VALUES ARE IN MICROHENRIES.

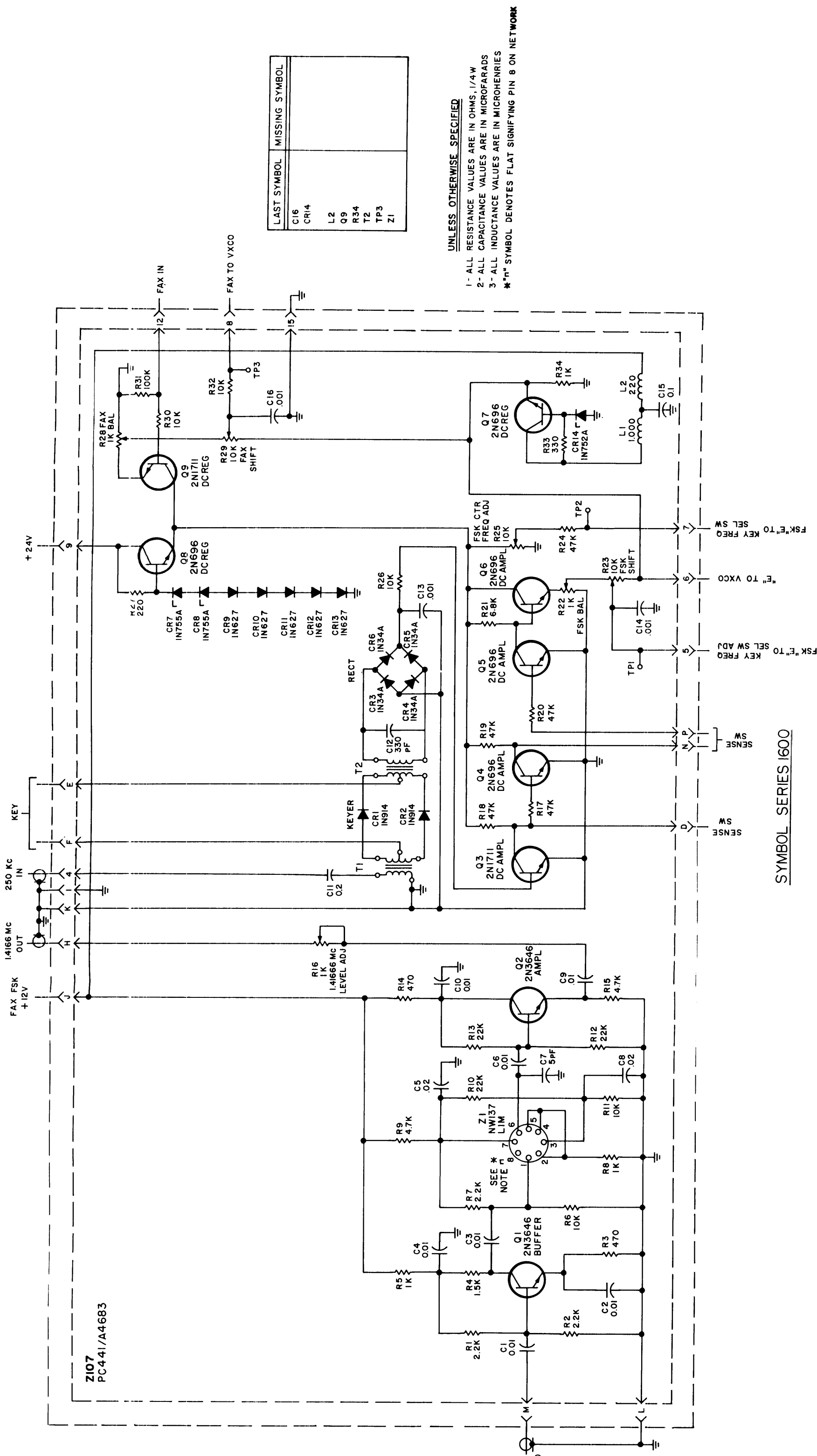
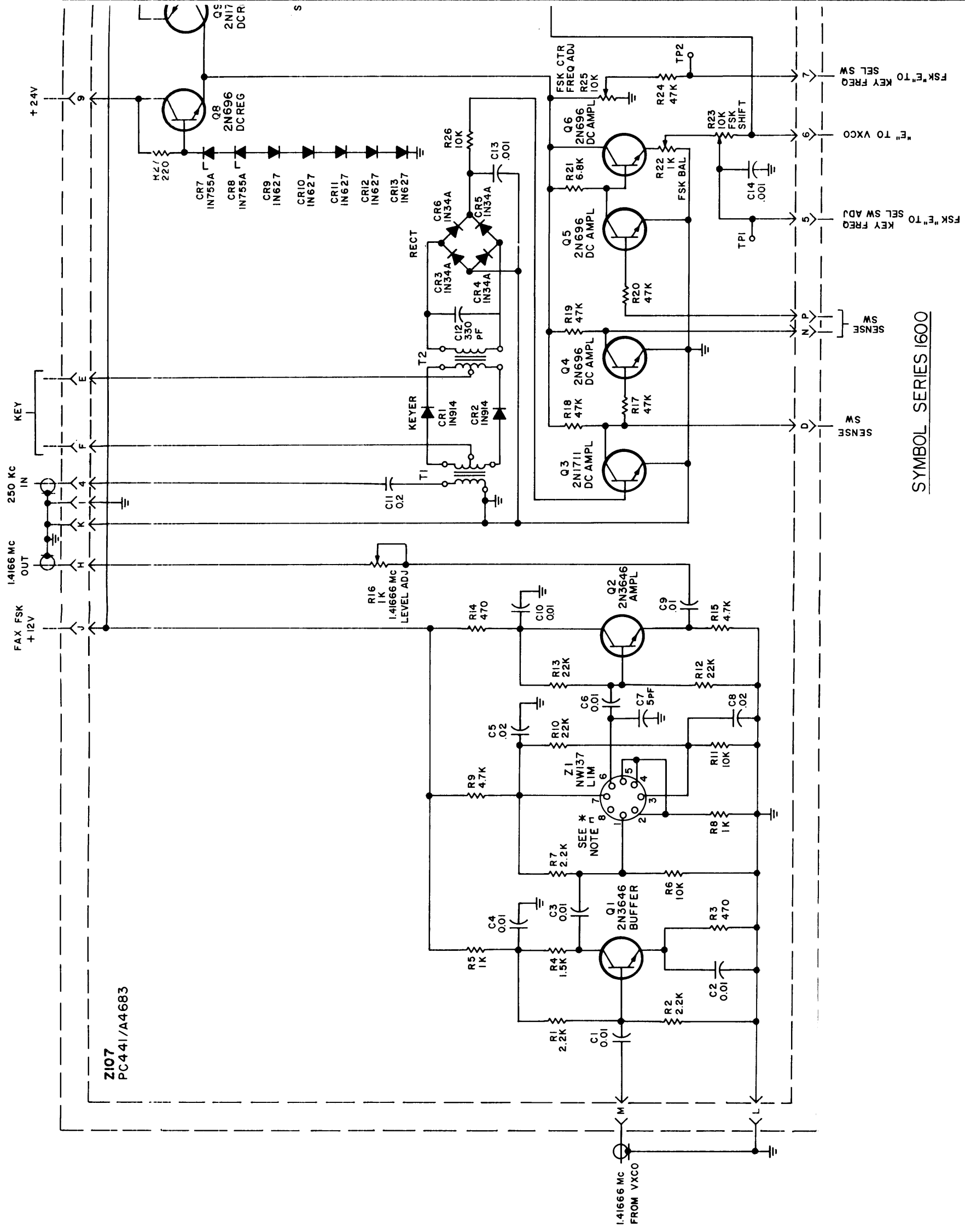

Figure 7-5. Frequency Shift Generator Z107, Schematic Diagram

005692045



SYMBOL SERIES 1600

Figure 7-5. Frequency Sh

005692045

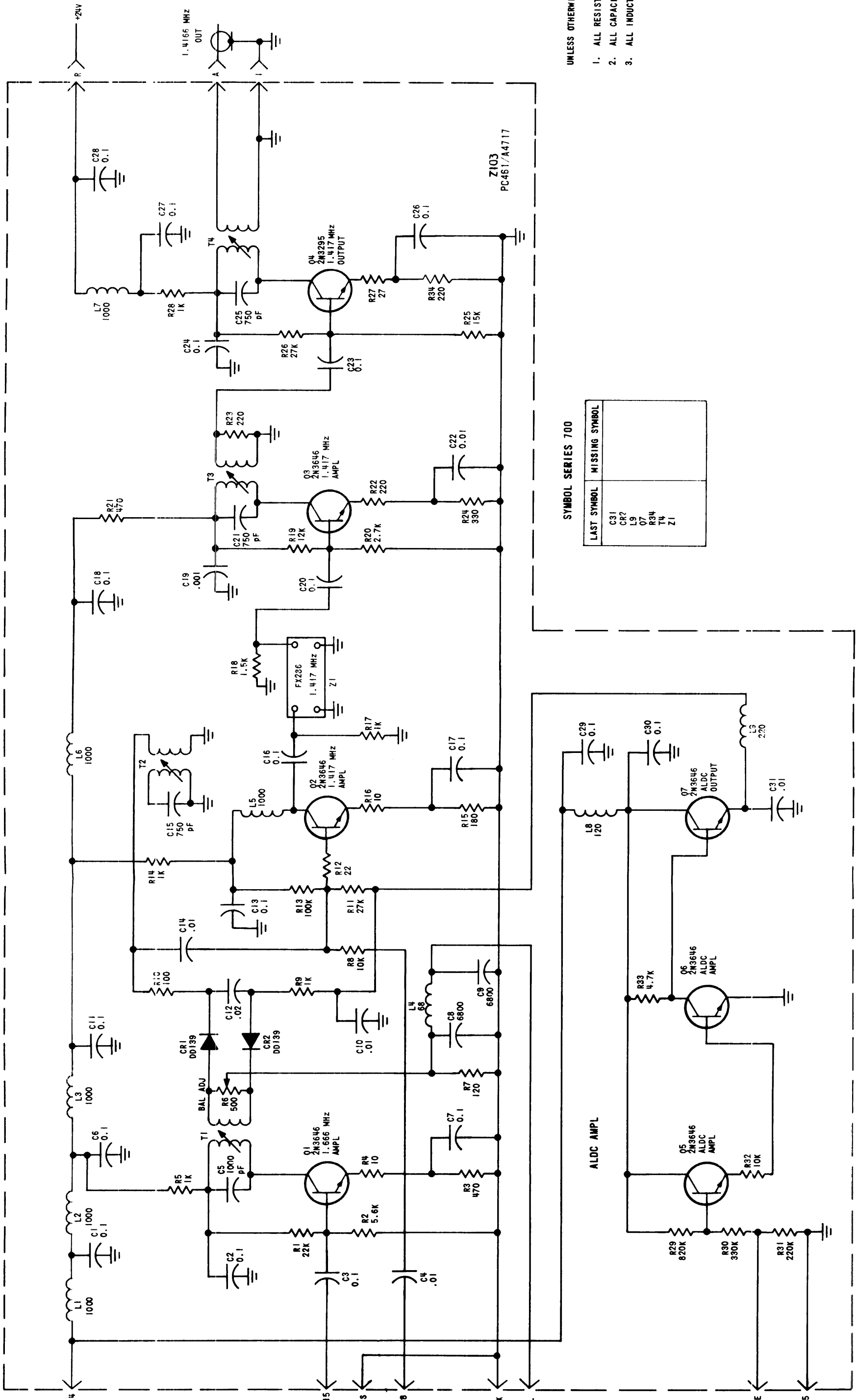

UNLESS OTHERWISE SPECIFIED:

1. ALL RESISTANCE VALUES ARE IN OHMS, 1/4W.
2. ALL CAPACITANCE VALUES ARE IN MICROFARADS.
3. ALL INDUCTANCE VALUES ARE IN MICRONS.

SYMBOL SERIES 700

LAST SYMBOL	MISSING SYMBOL
C31	
CR2	
L9	
O7	
R34	
T4	
Z1	

Figure 7-6. Converter and ALDC Z103, Schematic Diagram

005692045

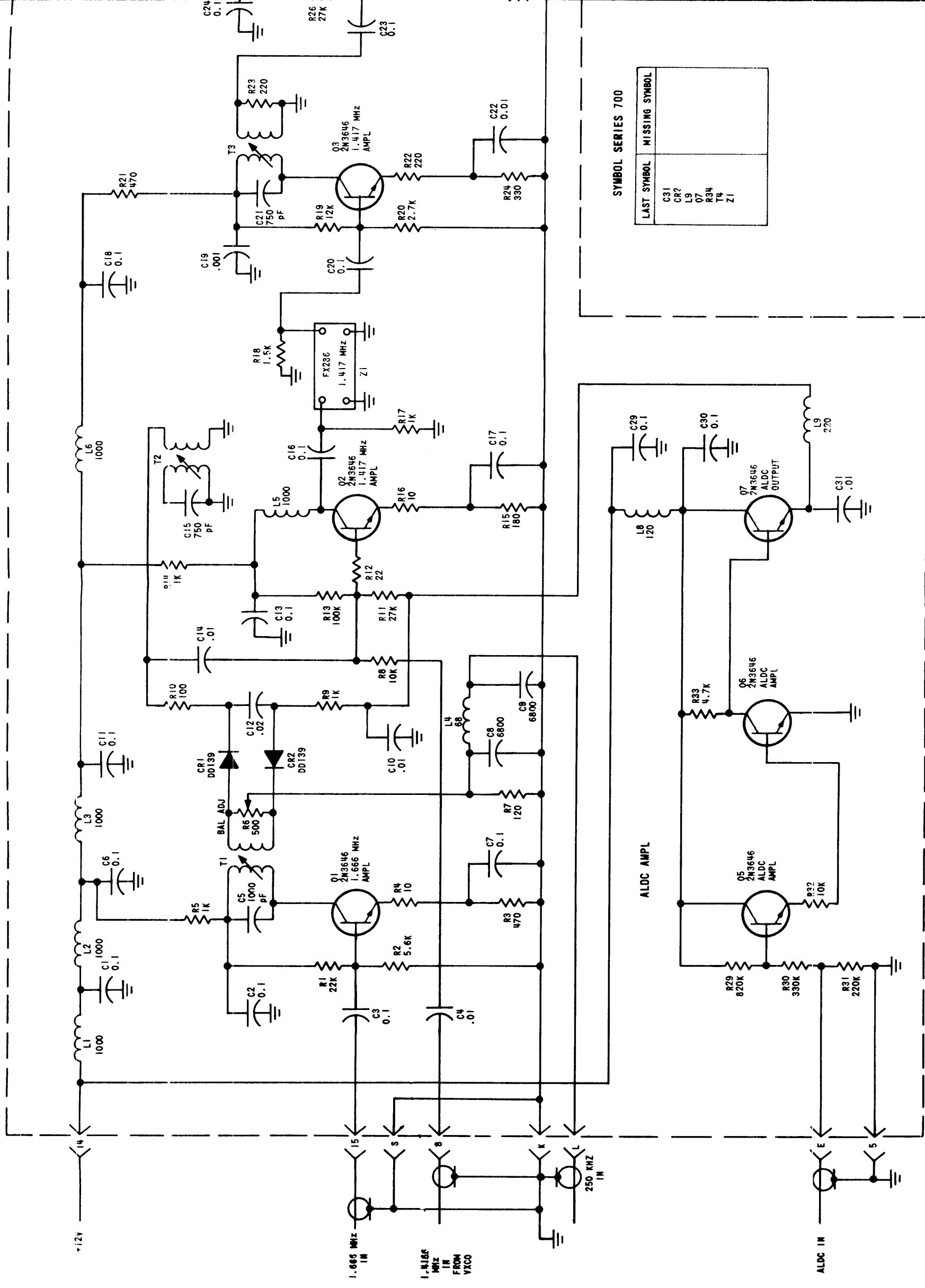

SYMBOL SERIES 700

LAST SYMBOL	MISSING SYMBOL
C31	
CR2	
L9	
Q7	
R34	
T4	
Z1	

Figure

005692045

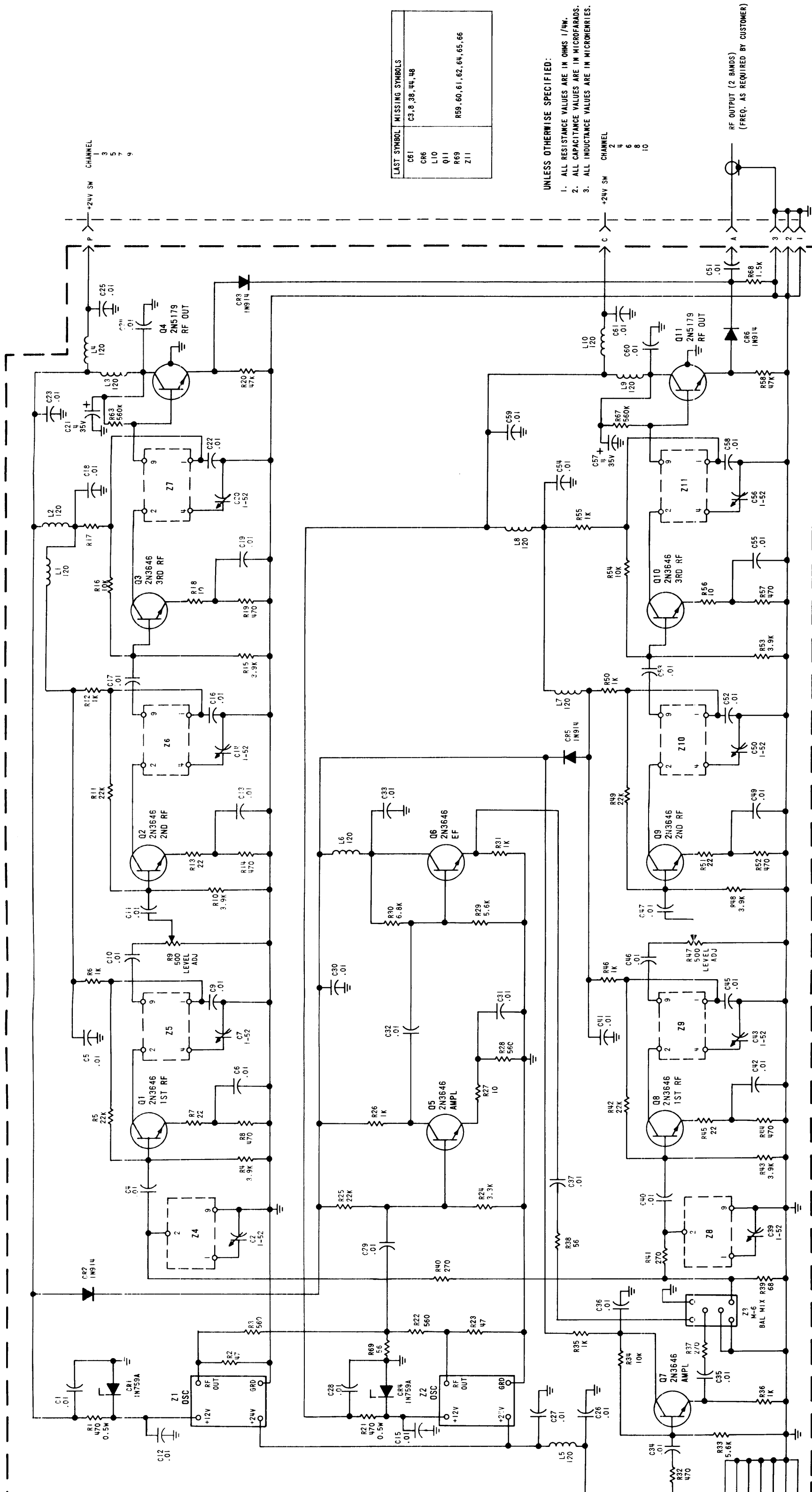

LAST SYMBOL	MISSING SYMBOLS
C61	C3, 8, 38, 44, 48
CR6	
L10	
Q11	
R69	R59, 60, 61, 62, 64, 65, 66
Z11	

UNLESS OTHERWISE SPECIFIED:

1. ALL RESISTANCE VALUES ARE IN OHMS 1/100.
2. ALL CAPACITANCE VALUES ARE IN MICROFARADS.
3. ALL INDUCTANCE VALUES ARE IN MICRORERIES.

Figure 7-7. RF Amplifier Z101, Z102, Z111, Z112 and Z113, Schematic Diagram

005692045

7-17/7-18

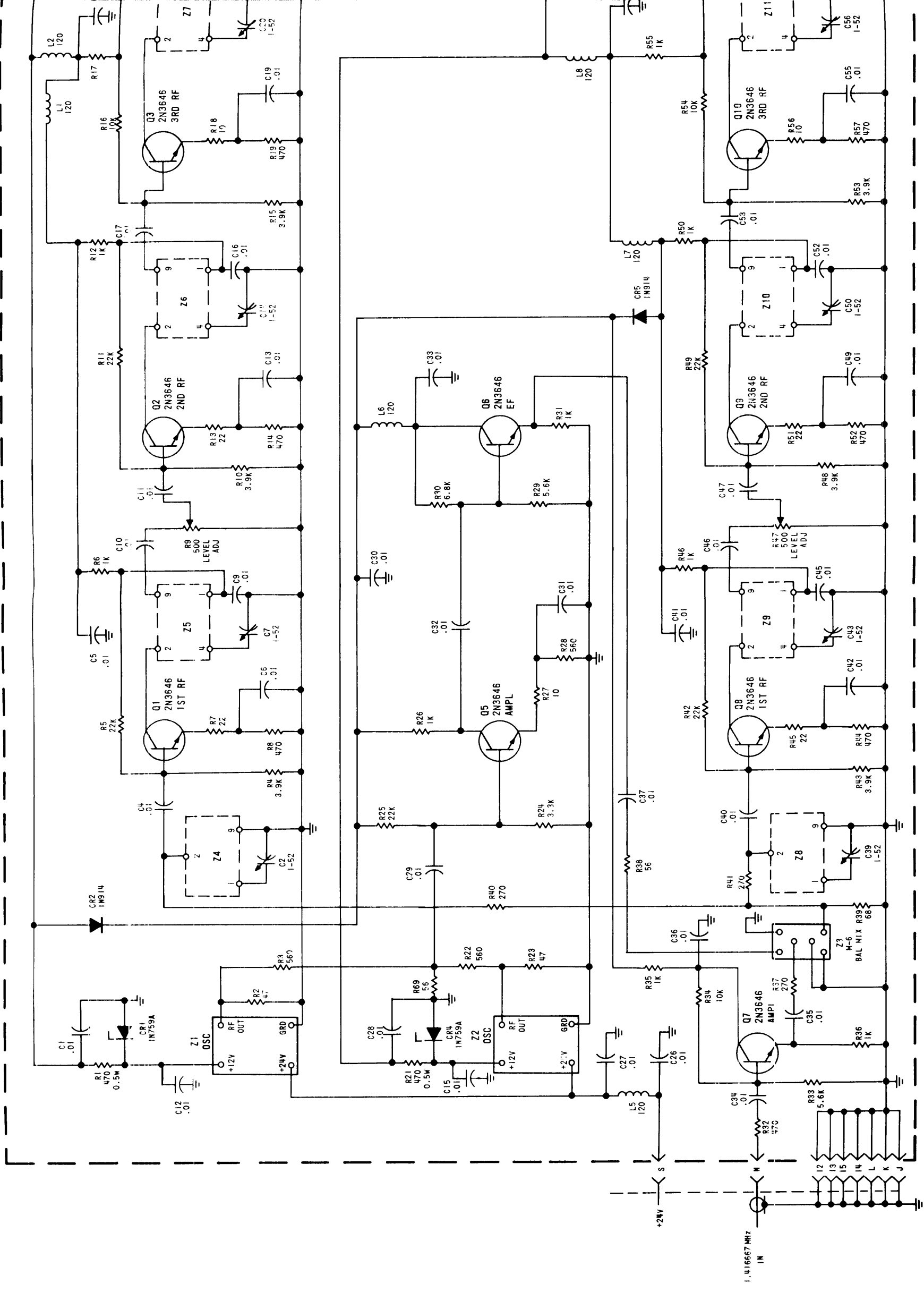

Figure 7-7. RF Amplifier

005692045

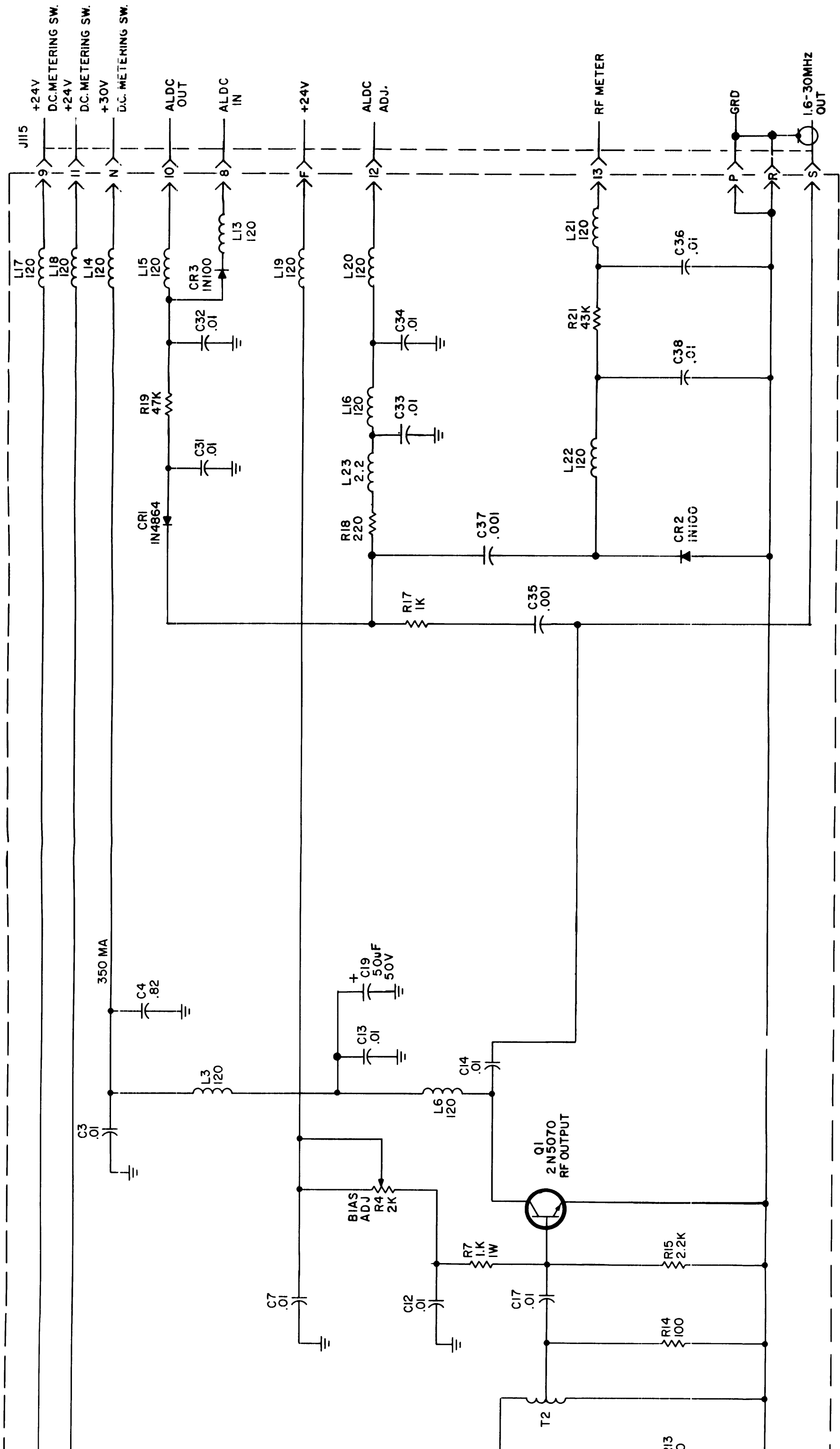

Figure 7-8. RF Output Z115, Schematic Diagram

005692045

PC306/A4502
Z115

65 MA

130 MA

P/O J115

1.6-30MHz
INPUT

B

A

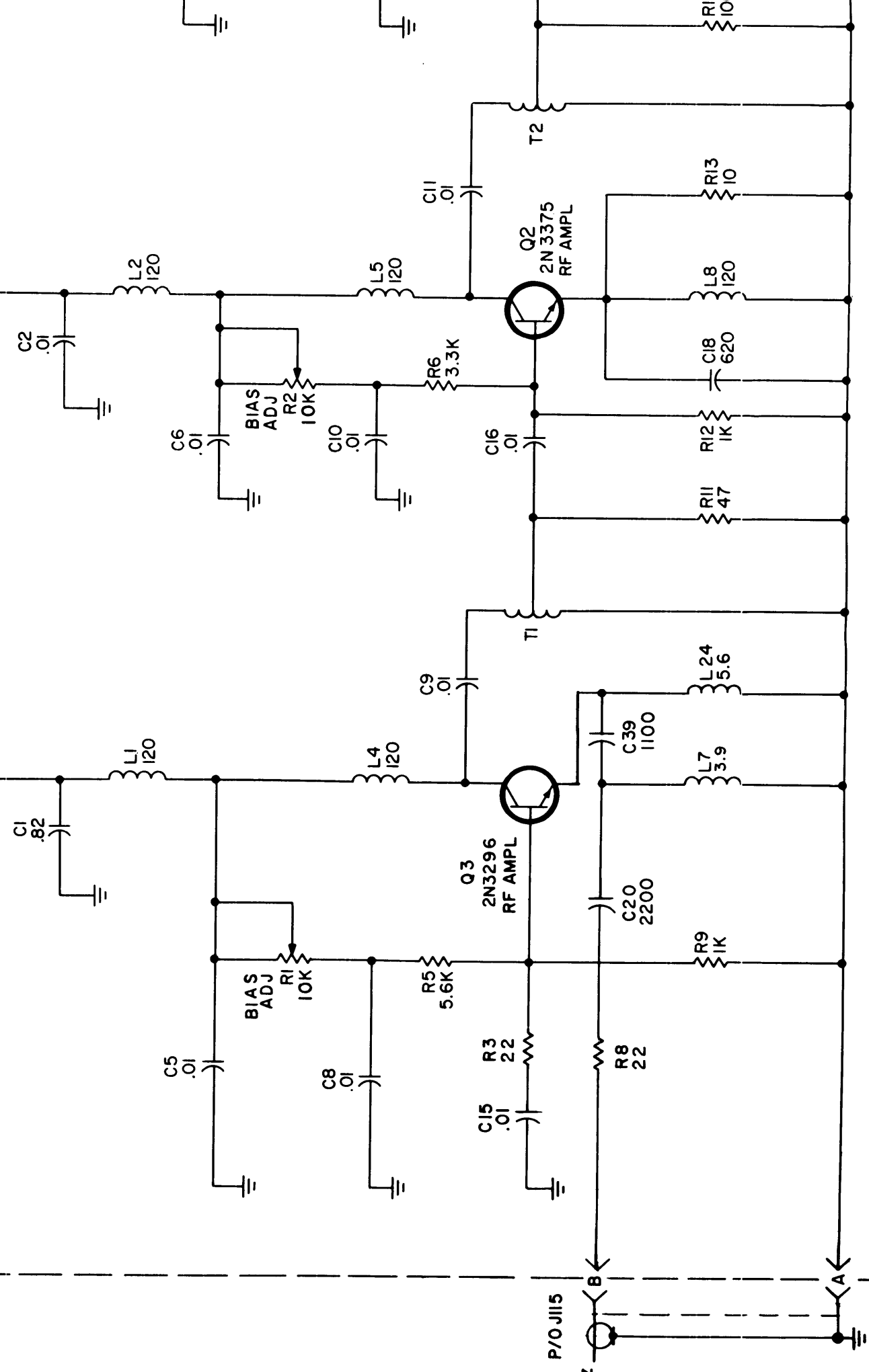

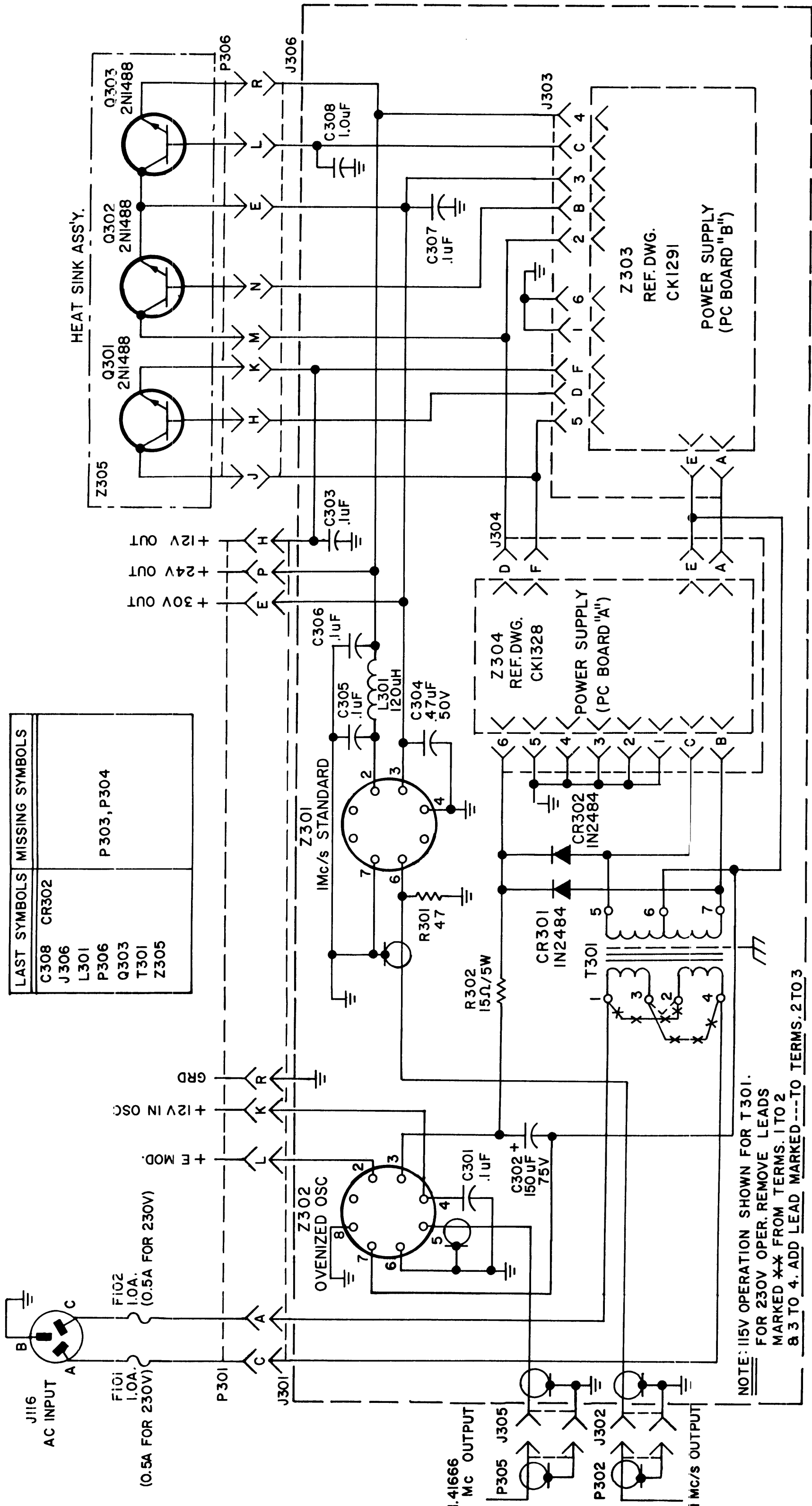

LAST SYMBOLS	MISSING SYMBOLS
C308	CR302
J306	
L301	
P306	P303, P304
Q303	
T301	
Z305	

NOTE: 115V OPERATION SHOWN FOR T301.
 FOR 230V OPER. REMOVE LEADS
 MARKED * FROM TERMS. 1 TO 2
 & 3 TO 4. ADD LEAD MARKED --- TO TERMS. 2 TO 3

Figure 7-9. Power Supply Assembly, Interconnection Diagram

005692045

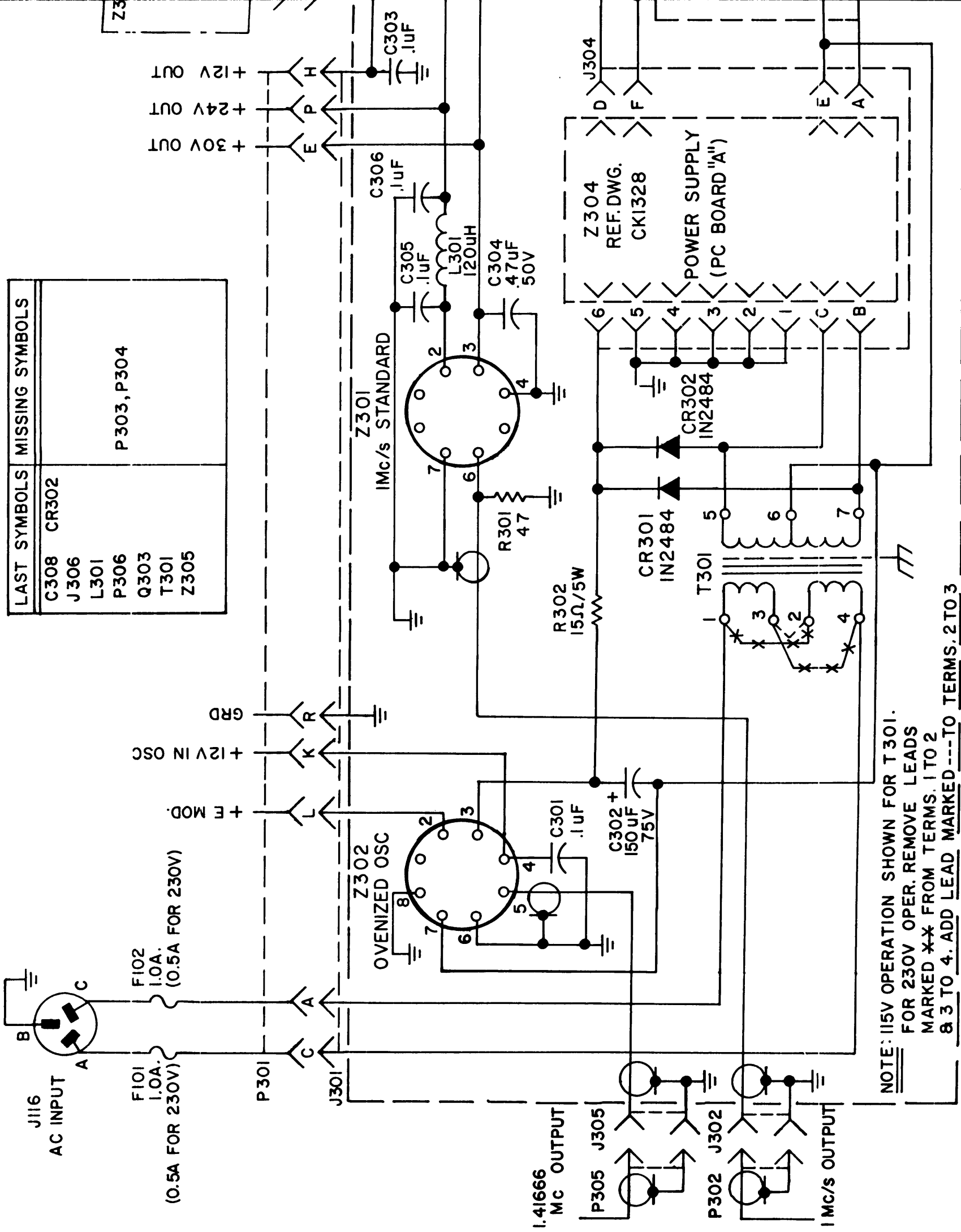

LAST SYMBOLS	MISSING SYMBOLS
C308	CR302
J306	
L301	
P306	
Q303	
T301	
Z305	
P303, P304	

Figure 7-9. Power S

005692045

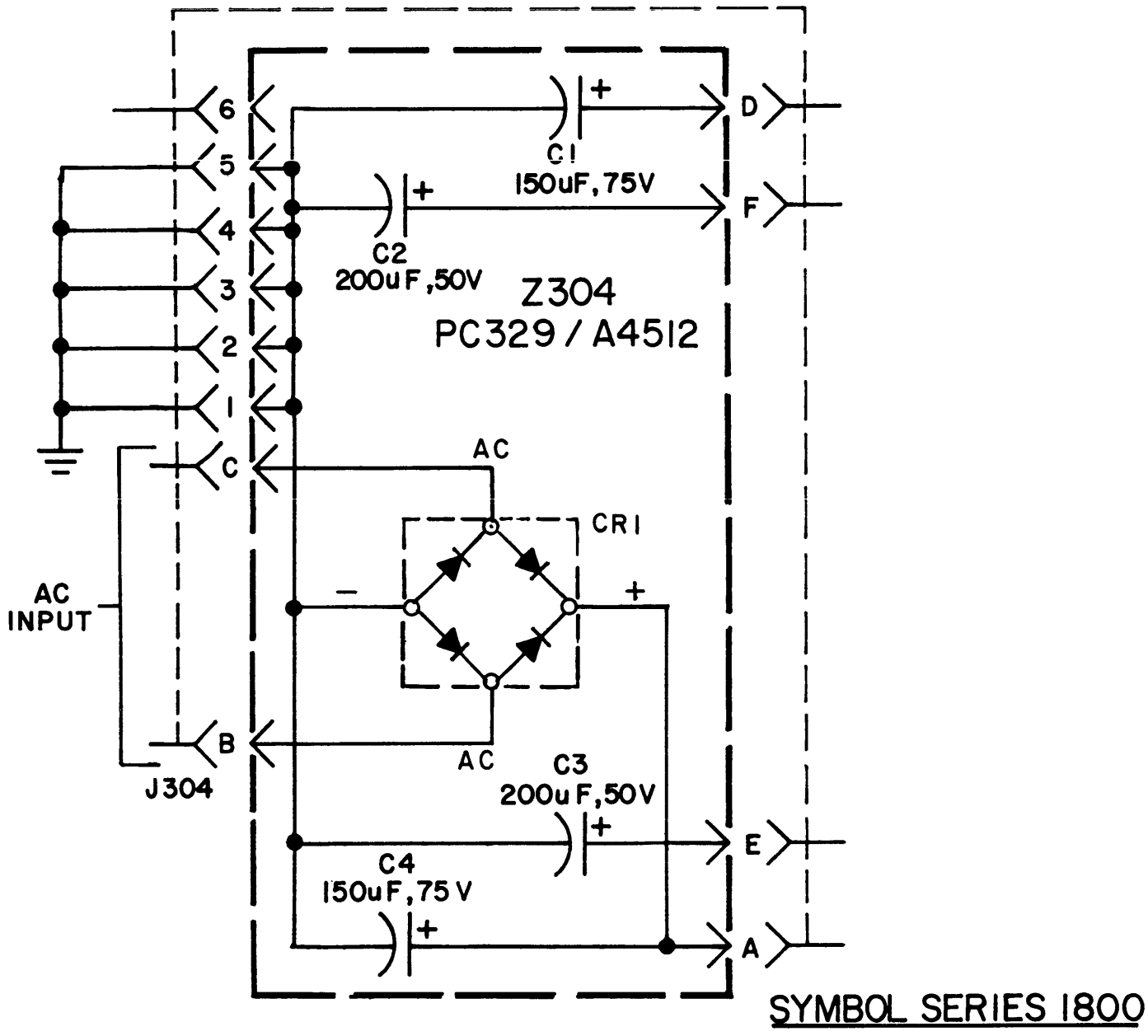
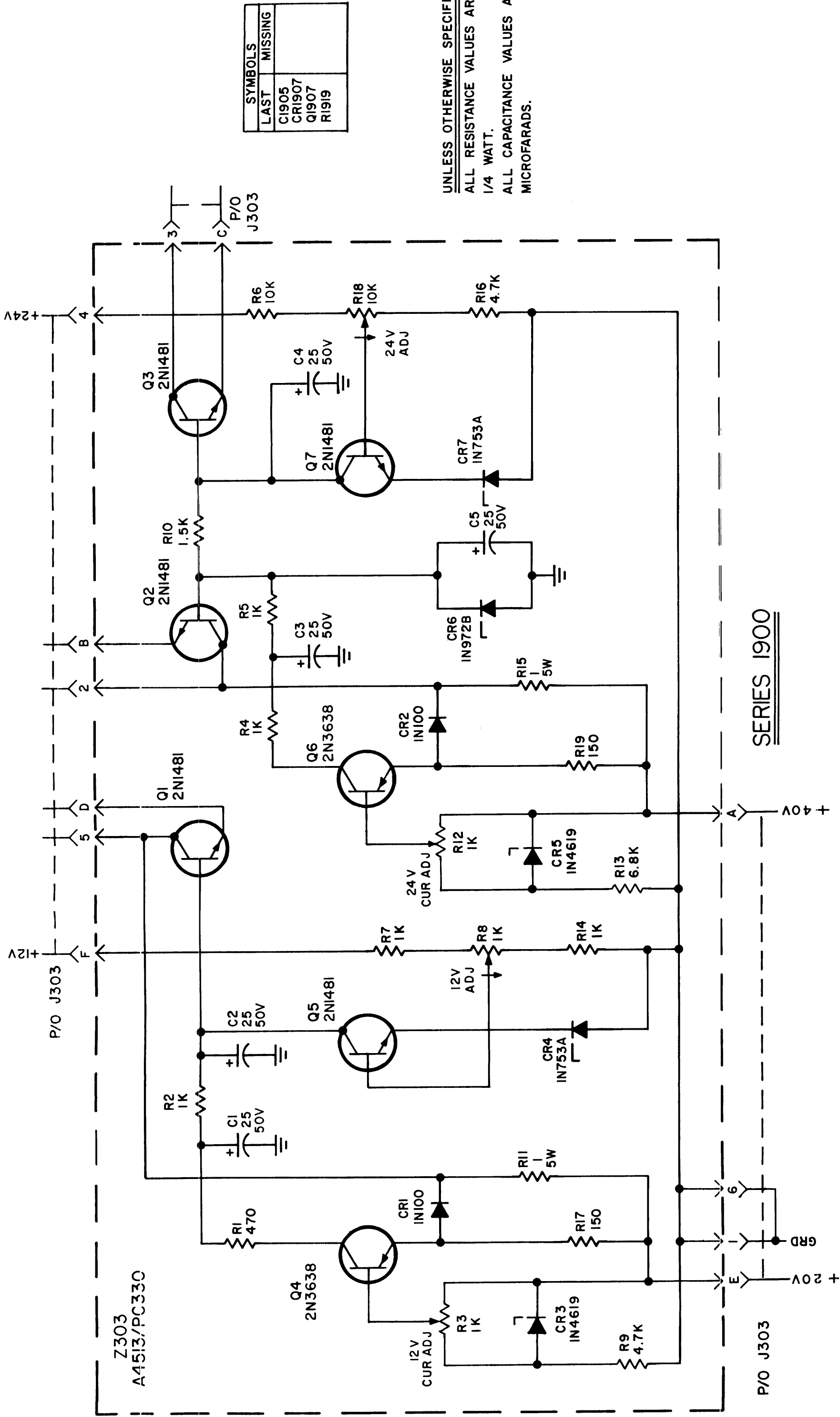

Figure 7-10. Rectifier-Filter Z304, Schematic Diagram



SYMBOLS	
LAST	MISSING
C1905	
CR1907	
Q1907	
R1919	

UNLESS OTHERWISE SPECIFIED:
 ALL RESISTANCE VALUES ARE IN OHMS,
 1/4 WATT.
 ALL CAPACITANCE VALUES ARE IN
 MICROFARADS.

Figure 7-11. Regulator Z303, Schematic Diagram

005692045

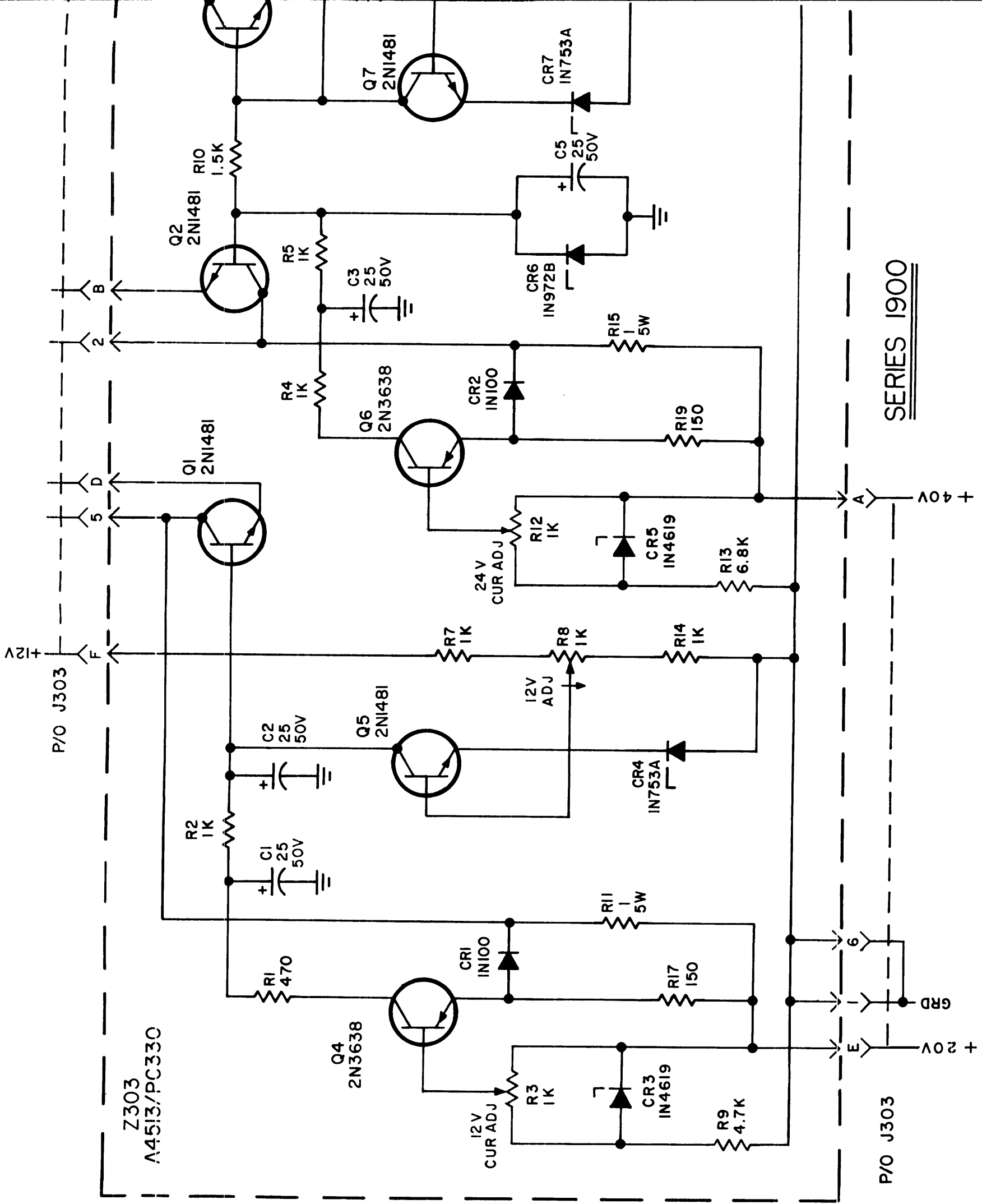

Figure 7-11. R

005692045