

TECHNICAL MANUAL
for

OPERATORS MANUAL

for

GENERAL PURPOSE LINEAR POWER AMPLIFIER

MODEL TMA-1KC

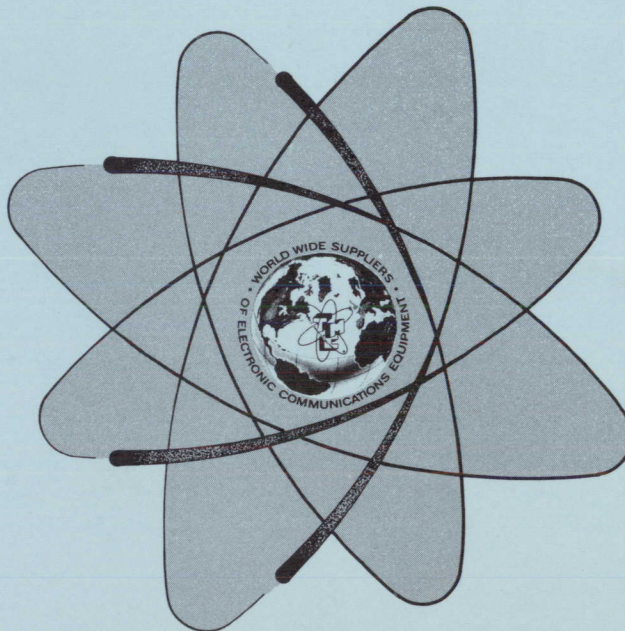

THE TECHNICAL MATERIEL CORPORATION
MAMARONECK, N.Y.

OTTAWA, ONTARIO

COPYRIGHT 1971
THE TECHNICAL MATERIEL CORPORATION

Printed in U.S.A.

OPERATORS MANUAL
for
GENERAL PURPOSE LINEAR POWER AMPLIFIER
MODEL TMA-1KC

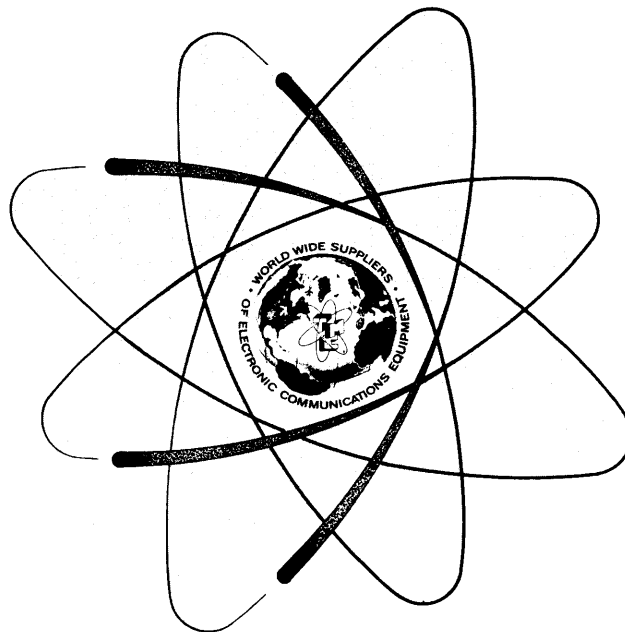

THE TECHNICAL MATERIEL CORPORATION
MAMARONECK, N. Y. OTTAWA, ONTARIO

COPYRIGHT 1971
THE TECHNICAL MATERIEL CORPORATION

Printed in U.S.A.

NOTICE

THE CONTENTS AND INFORMATION CONTAINED IN THIS INSTRUCTION MANUAL IS PROPRIETARY TO THE TECHNICAL MATERIEL CORPORATION TO BE USED AS A GUIDE TO THE OPERATION AND MAINTENANCE OF THE EQUIPMENT FOR WHICH THE MANUAL IS ISSUED AND MAY NOT BE DUPLICATED EITHER IN WHOLE OR IN PART BY ANY MEANS WHATSOEVER WITHOUT THE WRITTEN CONSENT OF THE TECHNICAL MATERIEL CORPORATION.

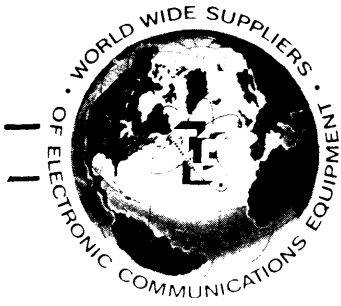

THE TECHNICAL MATERIEL CORPORATION

C O M M U N I C A T I O N S E N G I N E E R S

700 FENIMORE ROAD

MAMARONECK, N. Y.

W a r r a n t y

The Technical Materiel Corporation, hereinafter referred to as TMC, warrants the equipment (except electron tubes, *fuses, lamps, batteries and articles made of glass or other fragile or other expendable materials) purchased hereunder to be free from defect in materials and workmanship under normal use and service, when used for the purposes for which the same is designed, for a period of one year from the date of delivery F.O.B. factory. TMC further warrants that the equipment will perform in a manner equal to or better than published technical specifications as amended by any additions or corrections thereto accompanying the formal equipment offer.

TMC will replace or repair any such defective items, F.O.B. factory, which may fail within the stated warranty period, PROVIDED:

1. That any claim of defect under this warranty is made within sixty (60) days after discovery thereof and that inspection by TMC, if required, indicates the validity of such claim to TMC's satisfaction.
2. That the defect is not the result of damage incurred in shipment from or to the factory.
3. That the equipment has not been altered in any way either as to design or use whether by replacement parts not supplied or approved by TMC, or otherwise.
4. That any equipment or accessories furnished but not manufactured by TMC, or not of TMC design shall be subject only to such adjustments as TMC may obtain from the supplier thereof.

Electron tubes furnished by TMC, but manufactured by others, bear only the warranty given by such other manufacturers. Electron tube warranty claims should be made directly to the manufacturer of such tubes.

TMC's obligation under this warranty is limited to the repair or replacement of defective parts with the exceptions noted above.

At TMC's option any defective part or equipment which fails within the warranty period shall be returned to TMC's factory for inspection, properly packed with shipping charges prepaid. No parts or equipment shall be returned to TMC, unless a return authorization is issued by TMC.

No warranties, express or implied, other than those specifically set forth herein shall be applicable to any equipment manufactured or furnished by TMC and the foregoing warranty shall constitute the Buyers sole right and remedy. In no event does TMC assume any liability for consequential damages, or for loss, damage or expense directly or indirectly arising from the use of TMC Products, or any inability to use them either separately or in combination with other equipment or materials or from any other cause.

*Electron tubes also include semi-conductor devices.

PROCEDURE FOR RETURN OF MATERIAL OR EQUIPMENT

Should it be necessary to return equipment or material for repair or replacement, whether within warranty or otherwise, a return authorization must be obtained from TMC prior to shipment. The request for return authorization should include the following information:

1. Model Number of Equipment.
2. Serial Number of Equipment.
3. TMC Part Number.
4. Nature of defect or cause of failure.
5. The contract or purchase order under which equipment was delivered.

PROCEDURE FOR ORDERING REPLACEMENT PARTS

When ordering replacement parts, the following information must be included in the order as applicable:

1. Quantity Required.
2. TMC Part Number.
3. Equipment in which used by TMC or Military Model Number.
4. Brief Description of the Item.
5. The *Crystal Frequency* if the order includes crystals.

PROCEDURE IN THE EVENT OF DAMAGE INCURRED IN SHIPMENT

TMC's Warranty specifically excludes damage incurred in shipment to or from the factory. In the event equipment is received in damaged condition, the carrier should be notified immediately. Claims for such damage should be filed with the carrier involved and not with TMC.

All correspondence pertaining to Warranty Claims, return, repair, or replacement and all material or equipment returned for repair or replacement, within Warranty or otherwise, should be addressed as follows:

THE TECHNICAL MATERIEL CORPORATION
Engineering Services Department
700 Fenimore Road
Mamaroneck, New York

TABLE OF CONTENTS

<u>Paragraph</u>		<u>Page</u>
<u>SECTION 1 - GENERAL INFORMATION</u>		
1-1	Functional Description	1-1
1-2	Physical Description	1-1
1-3	Reference Data	1-1
<u>SECTION 2 - INSTALLATION</u>		
2-1	Initial Unpacking and Inspection	2-1
2-2	Power Requirements	2-1
2-3	Initial Installation	2-2
<u>SECTION 3 - OPERATOR'S SECTION</u>		
3-1	General	3-1
3-2	Operating Controls	3-1
3-3	Preliminary Procedures	3-2
3-4	Operating Procedure	3-2
3-5	Operator Maintenance	3-8
<u>SECTION 4 - PRINCIPLES OF OPERATION</u>		
4-1	General	4-1
4-2	Functional Analysis	4-1
	a. General	4-1
	b. Power Distribution	4-2
	c. Tuning Circuits	4-2
	d. Channelizing New Frequency	4-2
	e. PTT Relay K101 Push-to-Talk	4-2
	f. K102 Interlock & Overload Relay	4-3
	g. K103 Low Frequency Loading	4-3
	h. Meter Cal R121	4-3
	i. Z103 ALDC Rectifier Ass'y A5648	4-4
	j. Z104 DC Coupler	4-4
	k. Bandswitch Ledex Control Remote	4-4
	l. Power Supply	4-5
	m. Z101 Overload Board	4-5
	n. SWR Overload	4-6
	p. RF Indicator	4-6
	r. HFL Overload	4-7
	s. Remote Overload Reset	4-7
	t. ALDC	4-7
	u. RF Signal Circuit	4-8

TABLE OF CONTENTS

<u>Paragraph</u>		<u>Page</u>
5	<u>SECTION 5 - MAINTENANCE AND TROUBLESHOOTING</u>	
5-1	General	5-1
5-2	Preventive Maintenance	5-1
5-3	Performance Tests	5-2

SECTION 6 - PARTS LIST

LIST OF TABLES

<u>Table</u>		<u>Page</u>
1-1	Technical Specifications.	1-2
1-2	Power Tube Complement	1-2
2-1	Terminal Board Connections	2-3
2-2	Rear Panel Connections	2-4
3-1	Front Panel Controls and Indicators	3-1

LIST OF ILLUSTRATIONS

<u>Figure</u>		<u>Page</u>
1-1	General Purpose Linear Power Amplifier	1-0
2-1	110V to 220V Transformer Wiring Diagram	2-2
3-1	Controls and Indicators	3-7
4-1	Schematic Diagram TMA-1KC Overall	4-9
4-2	Schematic Diagram DC Coupler	4-10
4-3	Schematic Diagram Adjusts, Indicators	4-11
6-1	Component Location Z101 (A5643)	6-11
6-2	Component Location Z102 (A5644)	6-12
6-3	Component Location Z103 (A5648)	6-13

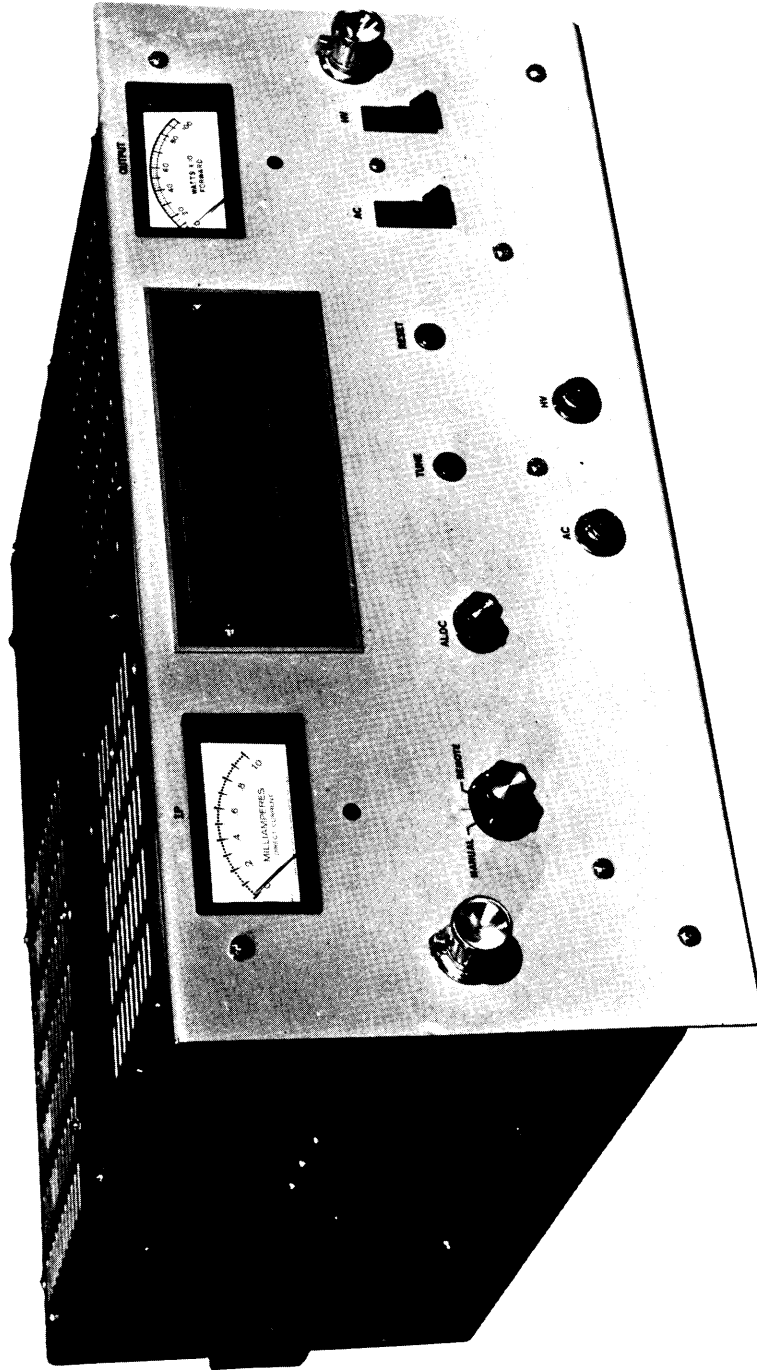

GENERAL PURPOSE LINEAR POWER AMPLIFIER

FIGURE I-1

SECTION 1

GENERAL INFORMATION

1-1. FUNCTIONAL DESCRIPTION

The general purpose linear power amplifier, Model TMA-1KC shown in figure 1-1, was designed and manufactured by The Technical Materiel Corporation (TMC) of Mamaroneck, New York. The unit will supply 1000 watts PEP (peak envelope power) with 4 channels output power over a frequency range of 2.0 to 26.0 MHz when provided with an input signal of 50 watts average power. A channelizing Ledex is used to control frequency output of amplifier when band select information is provided to the automated band switch of the TMA-1KC. This band select information may be supplied by the associated driving unit such as the model SME-5C exciter or the correct band manually selected by operating a band select switch on the front panel. The amplifier is factory wired for operation from either a 110 or a 220 volt, 50/60Hz power source, as required by the specific installation.

1-2. PHYSICAL DESCRIPTION

The TMA-1KC linear power amplifier is a compact, relatively light weight unit (approximately 55 lbs). It is completely solid-state with the exception of the two 8163 air-cooled amplifier tubes and protective relay. All of the controls and indicators are located on the 19 x 9 inch front panel (refer to figure 1-1). Protective fuses, and connectors for the input and output signals are located at the rear of the 18 inch deep chassis. The unit is designed for slide mounting in a standard equipment rack or cabinet. Panel locks and slide mount tracks are provided to position and secure the amplifier unit in the rack or cabinet.

1-3. REFERENCE DATA

Table 1-1 lists the technical specifications of the linear power amplifier, TMA-1KC.

TABLE 1-1. TECHNICAL SPECIFICATIONS

FREQUENCY RANGE:	2.0 MHz to 26 MHz.
OPERATING MODES:	Capable of all standard modes of operation (CW, AM, AME, ISB, SSB, FAX, FSK), but independent upon the capabilities of the exciter being used.
POWER OUTPUT:	1000 watts peak envelope power (PEP).
OUTPUT IMPEDANCE:	50 ohms, unbalanced.
STABILITY AND FREQUENCY CONTROL:	Capable of stability within 1 part in 10 ⁸ but dependent upon the stability of the exciter being used.
TUNING:	Channelized 4 channels.
RF INPUT:	Provides 1000 watts PEP with an input of approximately 50 watts average power.
SPURIOUS SIGNALS:	At least 40 db down from the rated PEP output.
HARMONIC SUPPRESSION:	Second harmonic suppression better than 40 db with reference to full PEP output.
NOISE:	40 db down from rated PEP output.
COOLING:	Filtered forced air cooling.
ENVIROMENTAL:	Designed to operate in any ambient temperature between the limits of 0 to 50 degrees centigrade for humidity up to 90 percent.
PRIMARY POWER:	110/220, single phase, 50 Hz.
POWER REQUIREMENTS:	Approximately 1,250 watts.
SIZE:	9 inches high x 19 inches wide x 18 inches deep.
INSTALLED WEIGHT:	Approximately 55 lbs.
SPECIAL FEATURES:	Overload protection, controlled and adjustable ALDC, and safety interlocks.

TABLE 1-2. POWER TUBE COMPLEMENT

<u>REFERENCE DESIGNATION</u>	<u>TYPE</u>	<u>FUNCTION</u>
V101*	8163	PA
V102*	8163	PA

*Operated in parallel.

SECTION 2

INSTALLATION

2-1. INITIAL UNPACKING AND INSPECTION

The TMA-1KC linear power amplifier was thoroughly tested at The Technical Materiel Corporation test facility in conjunction with any associated TMC equipment. Following successful completion of all operational tests, it was packed and crated together with the required cabling and connectors. Power tubes vulnerable to shipping damage are also separately packed. When the TMA-1KC is a part of a TMC transmitter installation, all "loose items" (hardware, instruction manuals, connectors and the like) may be included in the transmitter package; however, all packing material should be carefully examined so that no items are overlooked.

The equipment should be carefully inspected at the installation site for indications of damage in transit. A claim should be filed with the carrier at once, if transit damage is discovered. The Technical Materiel Corporation will assist in rectifying such damage by recommending replacement parts and by describing repair methods.

2-2. POWER REQUIREMENTS

The TMA-1KC linear power amplifier requires a single phase source of 110/220 volts, 50 Hz ac power. The equipment has been factory wired for use with the ultimate power supply indicated by the customer. If a decision is made to use an alternate power source, wiring change to the primary windings of T101 and T102 must be made to accommodate a change in voltage. Figure 2-1 shows the changes which are required. These changes should be made prior to installation.

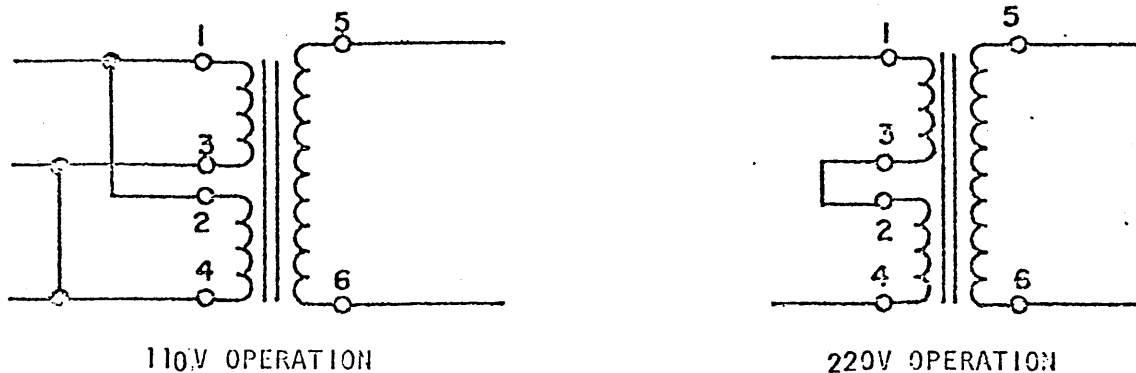

Figure 2-1. 110V to 220V TRANSFORMER WIRING DIAGRAM

WARNING

BE CERTAIN THAT THE UNIT IS CORRECTLY
WIRED BEFORE APPLYING PRIMARY POWER.

2-3. INITIAL INSTALLATION

The TMA-1K amplifier has been designed to be slide mounted in a standard equipment cabinet, and no special skill or instructions are necessary to fit the unit into place. The two 8163 power amplifying tubes (packed separately) must be reinstalled. Be sure that they are seated firmly in the sockets and make the plate connections to the top of the tubes with the hardware supplied. All the necessary electrical connections with associated equipment are made at the rear panel of the TMA-1KC amplifier. The connectors on the rear panel are clearly marked and referenced in tables 2-1 and 2-2. Reference should also be made to the internal interconnect wiring diagram for the TMA-1KC figure 2-2. Connectors for any cable which must be fabricated by the customer are furnished as "loose items".

TABLE 2-1. TERMINAL BOARD CONNECTIONS

<u>TERMINAL NUMBER</u> (from left to right)	<u>CONNECTION</u>
2	HFL Standby Overload
3	Remote RF Input
4	PTT
7	Common
8	HFL Overload
9	PTT
10	Remote HV Input
11	Channel 4
12	Channel 3
13	Channel 2
14	Channel 1
16	HV Time Delay
17	+ 24 volt
18	Remote interlock

NOTE

If a remote interlock is not used,
terminal 18 must be grounded to the
chassis.

TABLE 2-2. REAR PANEL CONNECTIONS

<u>REFERENCE DESIGNATION</u>	<u>PANEL NOMENCLATURE</u>	<u>FUNCTION</u>
J101	PWR IN	AC power input.
J103	RF IN	RF signal input from associated driving units.
J104	ALDC	Connects automatic load and drive control to associated driving units.
J105	RF OUT	Connects rf output signal to associated antenna equipment.
TB101	TB101	Refer to table 2-1.

Also located on the rear panel of the TMA-1K amplifier are the protective fuses for the following circuits: Ac input (F101), and control signal rectifier supply (F102).

SECTION 3
OPERATOR'S SECTION

3-1. GENERAL

The TMA-1KC linear power amplifier will amplify an input rf signal of approximately 50 watts average power to 1,000 watt PEP output signal. The TMA-1KC will operate satisfactorily at any frequency in the 2.0 to 26.0 MHz range. Four (4) pretuned RF circuits are incorporated and are Ledex Band-switched for fast channel switching (1 second nominal tuning time). By proper selection of L & C components the TMA-1KC can be programmed to any frequency from 2-26 MHz tuning range.

3-2. OPERATING CONTROLS

All of the controls and indicators are located on the front panel illustrated in figure 3-1. They are functionally indentified in Table 3-1.

TABLE 3-1. FRONT PANEL CONTROLS AND INDICATORS (Refer to figure 3-1)

<u>INDEX NUMBER</u>	<u>PANEL NOMENCLATURE</u>	<u>NATURE AND FUNCTION</u>
1	NONE	Panel lock (LH) - Secures unit in cabinet.
2	IP	Milliammeter - Displays plate current.
3	ALDC ADJUSTS	ALDC adjusts channels 1, 2, 3, and 4.
4	CHANNEL INDICATORS	Channel 1, 2, 3, and 4 indicators.
5	SWR INDICATOR	Indicator light (LED) - SWR
6	OUTPUT	Milliammeter - Displays output power (average) in watts.
7	NONE	Panel lock (RH) - Secures unit in cabinet.
8	MANUAL - REMOTE	Selector switch
9	ALDC	Potentiometer - Controls ALDC feedback voltage to exciter.

TABLE 3-1. FRONT PANEL CONTROLS AND INDICATORS (Refer to figure 3-1) (cont)

<u>INDEX NUMBER</u>	<u>PANEL NOMENCLATURE</u>	<u>NATURE AND FUNCTION</u>
10	AC	Indicating lamp - When lighted indicates AC power is applied.
11	TUNE	Manual bandswitch button
12	SWR OVLD ADJUST	SWR - Overload adjust
13	HV	Indicator lamp - Indicates the application of high voltage.
14	RESET	Pushbutton - Overload Reset
15	AC	Circuit breaker - Controls line power input.
16	HV	Circuit breaker - Controls primary power to high voltage transformer.
17	PLATE OVLD	Plate overload adjust.
18	RF ADJUST	RF Indicator level adjust
19	PLATE OVLD	Plate overload indicator
20	RF	RF Indicator.

3-3. PRELIMINARY PROCEDURES (Refer to figure 3-1.)

Before connecting the TMA-1KC amplifier to any power source make certain that the ac power switch (15) and the high voltage switch (16) are in the off (down) position, and that the operational mode selector switch (8) is in the REMOTE position if amplifier tuning is to be controlled by the associated drive unit (exciter). Also be sure that the TMA-1KC is securely mounted, and that all interconnections have been properly made.

3-4. OPERATING PROCEDURES

a. GENERAL. Usually the TMA-1KC linear power amplifier serves a component of a TMC transmitter system, and detailed operating procedures are given in technical manual for the system in relation to other system components. Here, the amplifier is treated as a separate entity but of necessity reference is made to other system components.

b. MANUAL OPERATION. (Refer to figure 3-1.)

- (1) Connect the power source to J101.

CAUTION

The output circuit must be connected to an antenna system or suitable resistive (50 ohm), 1KW dummy load through output jack (J105) before power is applied.

- (2) Set selector switch (8) to the MANUAL position.

CAUTION

Make sure that no input signal is applied to the RF IN jack (J103) prior to switching on the high voltage.

- (3) Set the AC switch (15) to the on (up) position. AC indicator lamp (10) lights. Channel indicator (4) lights. One minute time delay circuit is activated.

- (4) Press TUNE pushbutton (11) sequentially until indicator (4) shows the proper channel for the frequency of the rf input signal to be used.

- (5) After one minute set HV switch (16) to the on (up) position. HV indicator lamp (13) lights. Plate current meter (2) indicates 20 ma in standby, 180 - 200 ma with PTT energized.

- (6) Supply an rf signal to the amplifier from the associated equipment to J103 (RF IN). (With PTT energized)

(7) Increase the rf signal strength until an indication of plate current is observed on the IP meter (2) (approximately 250 ma).

CAUTION

Do not allow plate current to exceed
300 ma without RF output.

(8) Check tuning of channel by slight adjustment of C124 CH1, C125 CH2, C126 CH3, C127 CH4. These adjustment are located on top cover of unit. Extreme caution must be exhibited when making this adjustment. Use insulated tuning tool.

(9) Increase the amplitude of the rf input signal until full output of 500 watts is achieved. The plate current indicated on the IP meter (2) should be 400 - 550 ma depending on the frequency. This completes the manual tuning procedure.

c. REMOTE OPERATION. (Refer to figure 3-1.)

(1) Connect the power source to J101. For Remote operation use the same procedure as above. The only difference is that channel bandswitch is now controlled by SME-5C and will follow channel selection of SME-5C.

A. ADJUSTMENTS

1. PLATE OVERLOAD

Drive transmitter to IP meter reading (2) of 300 ma. Turn RF adjust ccw until RF light goes out. Now adjust plate overload (17), until plate overload indicator lights and HV goes off. Now reduce RF drive to 200 ma and press reset button. Now adjust RF adjust (18) fully clockwise. Drive TMA to 300 ma by increasing drive. Overload should not come on and RF indicator should light. Reset RF indicator, adjust (18) as explained in step.

2. RF INDICATOR

Drive transmitter to approximately 200 watts. Adjust RF, adjust (18) to light RF indicator. Now reduce drive. RF indicator should go out.

3. SWR OVERLOAD ADJUSTMENT

SWR protection is incorporated to protect TMA from open circuit antenna or SWR above 3:1. If possible, a load of 150 ohm (Resistive) can be connected to transmitter for following adjustment, but if it is not available leave transmitter output unterminated. Care must be taken not to over drive transmitter. 250 watt forward power maximum. 1. Adjust SWR, adjust (12) until plate overload and SWR overload indicators are lite. Make this adjustment in channel that is midway between lowest and highest frequency. Reconnect correct 50 ohm load and press reset button. Overloads should not activate.

4. ALDC LEVEL ADJUST

Channel 1, 2, 3, and 4 ALDC adjusts are all set up using the same procedure. Manual ALDC has to be reset for each channel and is used only for local operations. Drive transmitter to 200 watts single TONE (AME with carrier fully inserted) (See SME-5C for procedure). Starting with channel 1, adjust output of transmitter to 600 watts. Adjust ALDC (3) to bring output down to

500 watts. Repeat this for remaining channels. Now connect microphone into circuit on SSB with normal voice patterns. ALDC should hold transmitters PEP power to 1 kw PEP approximately 200 watts peaks on output meter. It might be necessary to readjust ALDC on voice to achieve this.

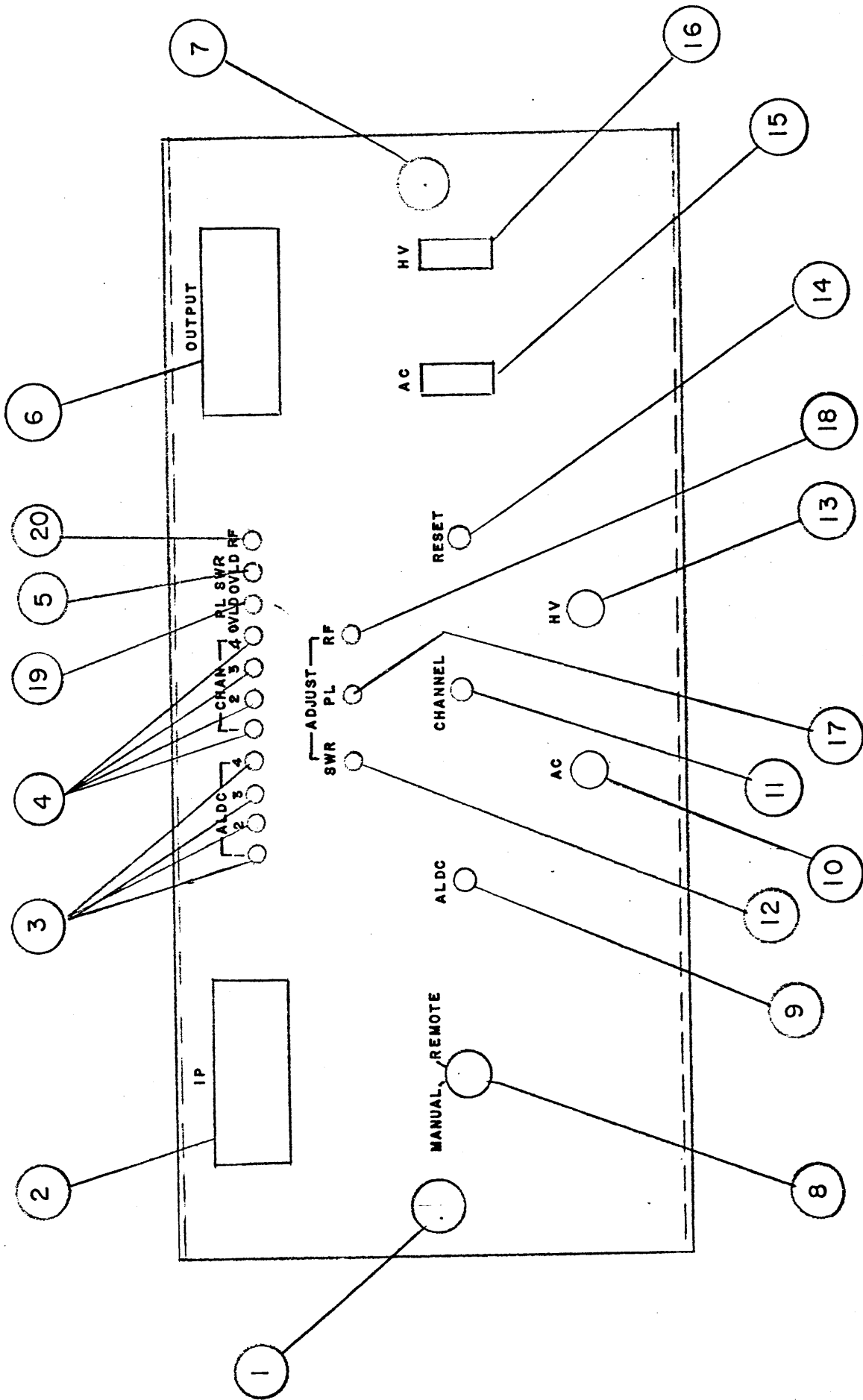

Figure 3-1, Front Panel Controls and Indicators

SECTION 4

PRINCIPLES OF OPERATION

4-1. GENERAL

The TMA-1KC linear power amplifier is designed to furnish 1KW PEP (peak envelope power) in the 2.0 to 26 MHz range. The unit is channelized to four pre-tuned frequencies. These can be controlled locally or remotely.

4-2. FUNCTIONAL ANALYSIS

The operation of the various circuits in the amplifier are discussed in the following paragraphs.

a. GENERAL. The system requires a power source of 110/220 volts ac at 50 or 60 Hz.

b. POWER DISTRIBUTION. (Refer to figure 4-1.) Power is supplied to the amplifier through J101. When switch (actually a circuit breaker) S102 is closed, primary power is supplied to transformer T101, and to blower motors B101 and B102. The primary power circuit for T101 is protected by fuse F101. The secondary winding of transformer T101 provides filament voltage (10 vac) to the power amplifier tubes V101, and V102. This secondary also supplies 22.5 vac to the diode bridge rectifier circuit, CR101. The rectifier circuit furnishes the 24 vdc signal voltage used throughout the unit and in associated equipment. The rectifier circuit is protected by fuse F102.

When switch/circuit breaker S101 is closed, primary power is supplied to the high voltage transformer T102 providing that interlocks S106, and S107 are closed and time delay Z101 has timed out allowing the 24 vdc control

voltage to actuate relay K102. (Terminal 18 of TB101 must also have ground connection to complete relay circuit.)

The output of T102 is directed through a rectifier/doubler circuit and a plate voltage of 3.0 Kvdc is supplied to the power amplifier tubes V101, and V102.

c. TUNING CIRCUITS. Output tuning is accomplished by bandswitch S105 which is ledex controlled to one of four pre-tuned output circuits. By proper choice of six inductance, capacitance elements, any frequencies in the 2-26 MHz band can be tuned. The inductance (tank coil) has five taps which are removeable for frequency programming. (See CK2131 schematic for clarification, Figure 4-1).

The capacitor elements are made up of C124, 125, 126, and 127. These variable capacitors have a tuning range of 10-150 pf and will tune frequencies from 12-26 MHz without additional capacitors (CA). For frequencies below 12 MHz, it is necessary to add ceramic capacitors across tuning caps to extend their range. Refer to CK2131 to obtain CA valve for correct frequencies.

d. CHANNELIZING NEW FREQUENCY. In the event that new frequencies are required other than supplied by manufacturer, refer to CK2131 chart to find correct tap and capacitance combination. Always program Channel 1 to lowest frequency; Channel 2 to next lowest frequency and so on.

Caution - do not tune transmitter with top cover removed or without insulated screwdriver. All tuning should be done at the lowest RF drive possible.

e. PTT RELAY K101 PUSH TO TALK. When K101 is not energized as shown on CK2132, R102, 150 ohm resistor is connected in series with ground return of V101, V102. This resistor voltage drop develops back bias to cut tubes

quiescent current to almost zero and puts transmitter in Standby condition. A second set of contacts on this relay (normally closed) are used to interlock bandswitch program in operate mode. These contacts open trigger line to Q101 bandswitch control SCR when PTT is energized, thus assuring that transmitter cannot be accidentally channelized with RF drive.

f. K102 INTERLOCK & OVERLOAD RELAY. K102 relay controls HV on-Off by opening or closing primary of T102.

The negative or Ground side of relay is connected through interlocks S106, S107 top bottom covers. This line is brought out to TB101 terminal 18. By grounding this line through remote control circuits HV is remotely controlled. Terminal 18 is grounded by S103C in manual to allow operator to have HV control at local position.

The 24 V feed for K102 is fed through Z101 time delay R116 (125 ohm) and CR109 HV on-off for overload operation is controlled by SCR Q4 which in turn allows voltage to relay or to ground.

g. K103 LOW FREQUENCY LOADING. K103 relay controls series loading of output circuit. It is only used for frequencies in the 2-5 MHz range. Z102 diode program card is used to program K103 operation on wanted channels.

h. METER CAL R121. R121 meter calibrate is normally set up at factory. If there is a reason to check this calibration, extreme care must be taken when connecting meter into HV line. Make sure that unit is turned OFF and HV voltage is discharged. Connect Simpson meter or equivalent in series with L102 plate decoupling choke meter should be set on 500 milli-amp scale. With no drive to TMA and PTT energized, adjust R121 so M102 meter reading agrees with test meter. Approximately 200ma is normal.

i. Z103 ALDC RECTIFIER ASS'Y A5648. RF voltage fed through cap divider C146 3 pf and C7 18 pf is rectified by diodes CR1, CR2 to provide a plus and a minus dc voltage output for RF monitor, SWR and ALDC (-v). These dc voltages are directly proportioned to RF output of transmitter. ALDC negative voltage is fed to SME exciter for peak power level control. A positive back bias voltage is fed into E3 for threshold adjustment, (ALDC level adjust) a positive voltage output at E1 is used for RF indication and SWR overload. These will be explained later in text.

j. Z104 DC COUPLER. See Fig. 4-2, DC coupler consists of cap divider C1 and C2. For RF voltage pick up and inductance L1 air trimmer, RF current monitor and rectifier CR1. The resultant RF voltage, current coupling is rectified by CR1 diode to produce +dc voltage which is fed to output meter M101.

Meter circuit is calibrated at factory against standard coupler but in the event that recalibration is required, this is accomplished by adjusting capacitor C1.

CAUTION

Do not make this adjustment with power on. Always turn power OFF and discharge HV before adjustment is attempted. Turn screw CW to increase meter reading, CCW to decrease meter.

k. BANDSWITCH LEDEX CONTROL REMOTE. Ledex programming voltage is fed from SME-5 channel select sw. This voltage appears at one of four terminals on TB101 of TMA, Channel 1 term 14, Channel 2 terminal 13, Channel 3 term 12,

Channel 4 terminal 11. This voltage appears on S105B, Notch Homing Waffer, which in turn is fed to Q101 (2N1776) SCR trigger, with voltage present at trigger. SCR is turned on completing Ledex voltage to ground thus turning band to next channel. S108 is part of Ledex assembly and is mechanically tied to shaft with each 30° step of Ledex. S108 is opened and closed to turn SCR off by removing voltage at anode. This sequence continuous until Notch clears voltage input from SME-5C. When S103 is turned to manual operation Q101 Trigger voltage is removed from voltage charge of C121 when tune button is depressed. Each time the button is depressed, Ledex will advance one position. CR110 and R128 is put into trigger circuit to allow Ledex to spin around from channel 4 to channel 1 automatically.

Note that Trigger voltage to Q101 is routed thru PTT Relay K101 and unless transmitter is in standby bandswitch cannot be programmed.

1. POWER SUPPLY. Power supply is a voltage doubler circuit transformer. T102 supplies 550 VAC into doubler CR106, CR108 and make up full wave rectifier circuit. R108, R109, R111, and R115 resistors are current limiting resistors to protect receiver diodes. R112 to R123 make up HV power supply bleeder circuit. Series connected capacitor C128 to C136 make up filter capacitor assembly. HV voltage from supply is 3000v at .5 amp.

m. Z101 OVERLOAD BOARD. Reference to figure 4-3 or CK2132 figure 4-1, Z101 consists of plate overload SCR Q4, Q6 2N1711 SWR overload indicator SCR Q7, 2N1595, heat overload transistor Q3 2N1711, RF relay transistor Q8 and remote overload reset transistors Q1, Q2, and 2N1711. This assembly also consists of the following adjustments and indicators: plate overload, SWR adjust, RF adjust and 4 ALDC level adjusts, 1 for each channel. Plate overload indicator, SWR indicator, RF indicator, channel 1 indicator, channel 2 indicator, channel 3 indicator, channel 4 indicator and K1 relay for RF indication turn on.

Q4 SCR controls HV ON - OFF of the TMA by controlling current thru resistor R116 and relay K102 when this SCR is fired +24 volts to R116 is brought to ground thus deenergizing K102. Current increase through R12, 22 ohm will now lite plate overload lite DS5. Q4 SCR derives its trigger from 4 paths and will be activated by voltage across R18 (plate overload adjust), emitter of Q3, 2N1711 (heat overload), or voltage at collector of Q6 2N1711 (SWR overload).

Plate overload voltage is developed across R124, 5 ohm resistor in cathode return of V101, V102 and this voltage is proportional to current in tubes. R18 is adjusted for trip out at proper current overload. Normal voltage to fire SCR 1.5V. Note: R35, 22 ohm resistor. This resistor provides additional shunt to R18 to increase overload setting when K1 is energized or RF output of transmitter is correct. This is important and will be discussed later in the text. Heat overload will also fire Q4 plate overload, if thermostat S110 heat sensor for some reason (fan failure) etc. opens. The base of Q3 will conduct allowing voltage to the emitter which triggers Q4 SCR. This will show up as plate overload, but a heat overload can be seen immediately because a heat overload requires 1 - 2 minutes to cool off and reset, thus making it impossible to reset HV until S110 has cooled and is normally grounded.

n. SWR OVERLOAD. SWR overload also fires Q4 SCR and SWR indicator SCR Q7. Thus SWR overload results in two indicators being lite. Plate overload and SWR voltage +DC from Z103 is derived from rectifier CR1 which monitors RF through capacitor divider C146, C7. When antenna impedance is correct this DC voltage is normal but when SWR is inserted this voltage will change. This plus voltage is fed to SWR adjust R20 when voltage gets above threshold adjustment it will turn on Q6 making collector go from high to low, thus turning off Q5, 2N1711 which in turn allows collector to become high. This now supplies trigger for SCR's Q4 and Q7.

p. RF INDICATOR. +DC voltage is fed to R25, RF adjust. This plus voltage

will be present when RF output is present at 50 ohm transmitter output. This voltage turns on Q8 thus energizing K1 relay. This lights DS7 RF indicator on Z101. It also provides ground signal to TB101 terminal 3 for remote RF read-back.

K1 relay also connects R35, 22 ohm resistor to ground. This puts additional shunt on overload adjust. The purpose of this fixed shunt is to allow for 2 overload conditions. Normal conditions is when transmitter has no RF output and shunt is disconnected. Plate overload should be set to trip out approximately 300 ma (K1 not energized). When RF relay is energized plate current trip out will be extended to approximately 600 ma because of additional shunt. This circuit will protect transmitter when antenna is shorted or RF flashes to ground.

r. HFL OVERLOAD. When the HFL-100C is overloaded a voltage is fed to terminal 6 thru TB101-8 to the trigger of Q4 SCR for a system overload.

s. REMOTE OVERLOAD RESET. To reset Q4 and Q5 SCR's it is necessary to ground voltage at anodes (Pin 3) in local operation. This is accomplished by pressing S109 overload reset button and grounding anodes. In remote operation, Q1 and Q2 are used to reset this line. Voltage to turn on Q1 2N1711 is derived from relay K102 and is only present when terminal 18 of TB101 is ungrounded. This line is controlled remotely as HV ON-OFF and it should be noted that overload reset at remote control consists of turning HV OFF and then back ON. When Q1 base is turned ON, Q2 base is turned on making collector of Q2 low, thus resetting SCR's.

t. ALDC. Four (4) ALDC adjust positions are located on Z101. These adjustments are to allow individual ALDC adjustments for each channel. These adjust provide a varying + voltage to back bias ALDC circuits. In manual mode a separate ALDC control is used (front panel knob). ALDC is set up after transmitter has been properly tuned and all SME-5C levels have been established. The capture range of the ALDC should be such that peak power is held to 1 kw PEP and line voltage variations are allotted for.

u. RF SIGNAL CIRCUIT. The RF signal from the associated exciter/amplifier enters the TMA-1KC through input jack J103. The signal is then applied to the cathode circuit of the two parallel, grounded grid, triodes and amplified to a 500 watt (1KW PEP) level via the plate tuning and loading stages. It then goes through the output transformer T103, and the output coupler before being routed to the associated antenna system through output jack J105. An ALDC (automatic load and drive control) circuit incorporated into the rf output circuit, controls the output level of the associated exciter so that the operational limits of the amplifier are not exceeded.

The PA tubes employ zero bias. When a signal is applied to the tubes they are designed to operate efficiently as long as the plate circuit is properly tuned. Under zero signal conditions, the quiescent value of the tube current is approximately 200 ma; the plate current is kept to a safe level so that damage to the tubes will not occur. Two parasitic suppressors, PS101, and PS102 are incorporated in the output plate circuit to stop unintended self sustaining oscillations. The amplified plate signal is tuned by various band combinations of tuning capacitors C124 to C127 high frequency coil L107, tank coil L108 and bandswitch S105. The bandswitch S105 is controlled by the operation of the Ledex motor.

ZONE	LTR	REVISIONS	DATE	MINNO	GRANT	CHMD	APPRO
	X1	PC746/P/746 REV. 1012/76	10/12/76				
	X2	ON T8101 PIN 2 ADD C12					
	X3	ON T8101 PIN 2 ADD C12					
	X4	ON T8101 PIN 2 ADD C12					
	X5	ON T8101 PIN 2 ADD C12					
	X6	ON T8101 PIN 2 ADD C12					
	X7	ON T8101 PIN 2 ADD C12					
	X8	ON T8101 PIN 2 ADD C12					
	X9	ON T8101 PIN 2 ADD C12					
	X10	ON T8101 PIN 2 ADD C12					
	X11	ON T8101 PIN 2 ADD C12					
	X12	ON T8101 PIN 2 ADD C12					

FREQUENCY MHz	VALUE C.A	TAP
2.00	450	0
2.6	150	0
3	150	0
3	100	1
4	100	1
5	50	1
5	250	2
6	150	2
7	50	2
8	0	2
8	0	3
10	0	3
11	0	3
12	0	3
12	0	4
13	0	4
14	0	4
15	0	4
16	0	4
16	0	5
17	0	5
18	0	5
18	0	5
19	0	5
20	0	5
21	0	5
22	0	5
22	0	5
23	0	5
24	0	5
25	0	5
26	0	5

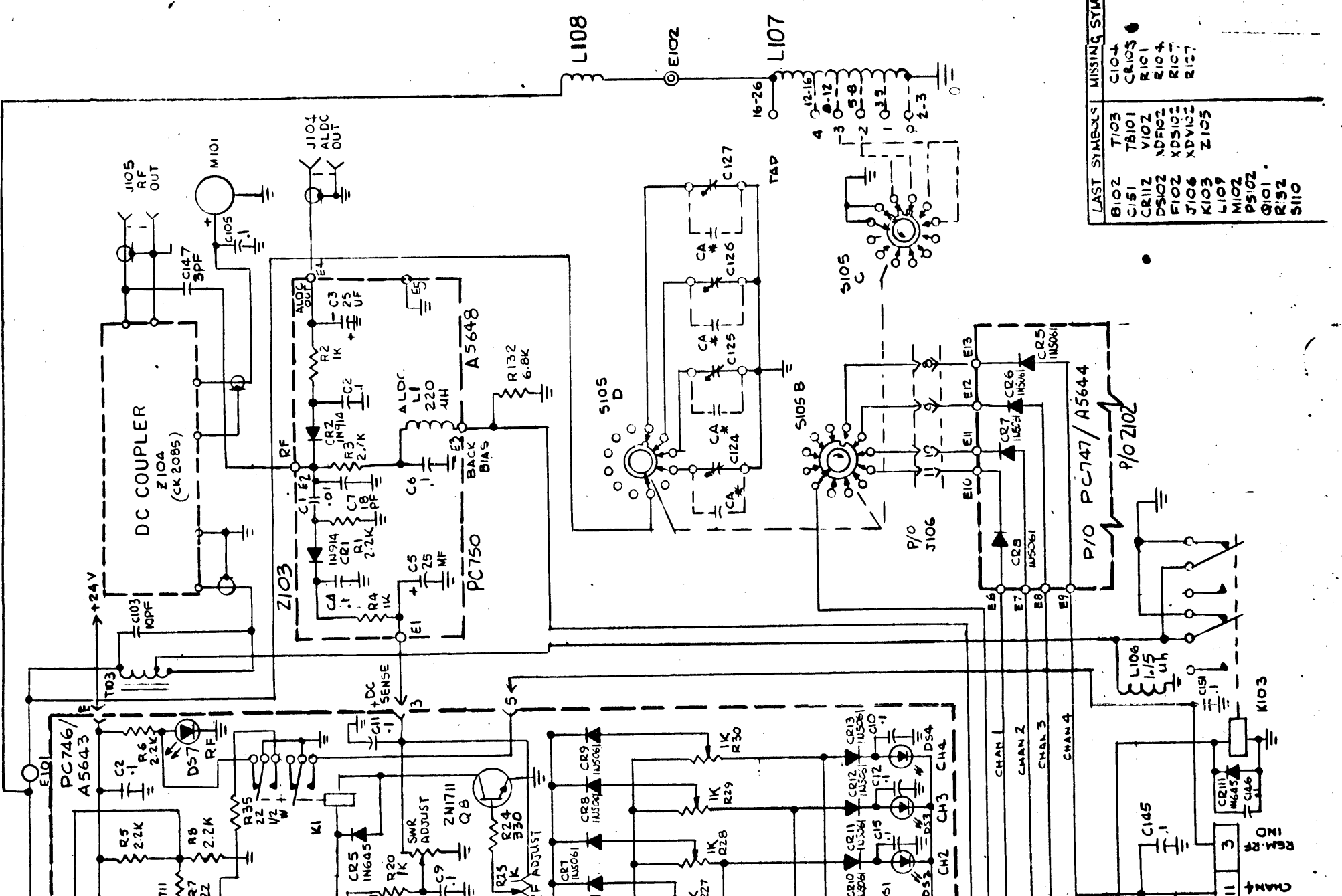

(A5643/PC746)
Z101

LAST SYM	MISSING SYM

LAST SYMBOLS	MISSING SYM
B102	C104
C151	CR103
CR112	R101
DS102	R104
F102	R107
J106	XD102
K103	Z105
L109	
M102	
PS102	
Q101	
R152	
S110	

CK2132
SCHEMATIC, DIAGRAM
TMA-1KC OVERALL

Figure 4-1

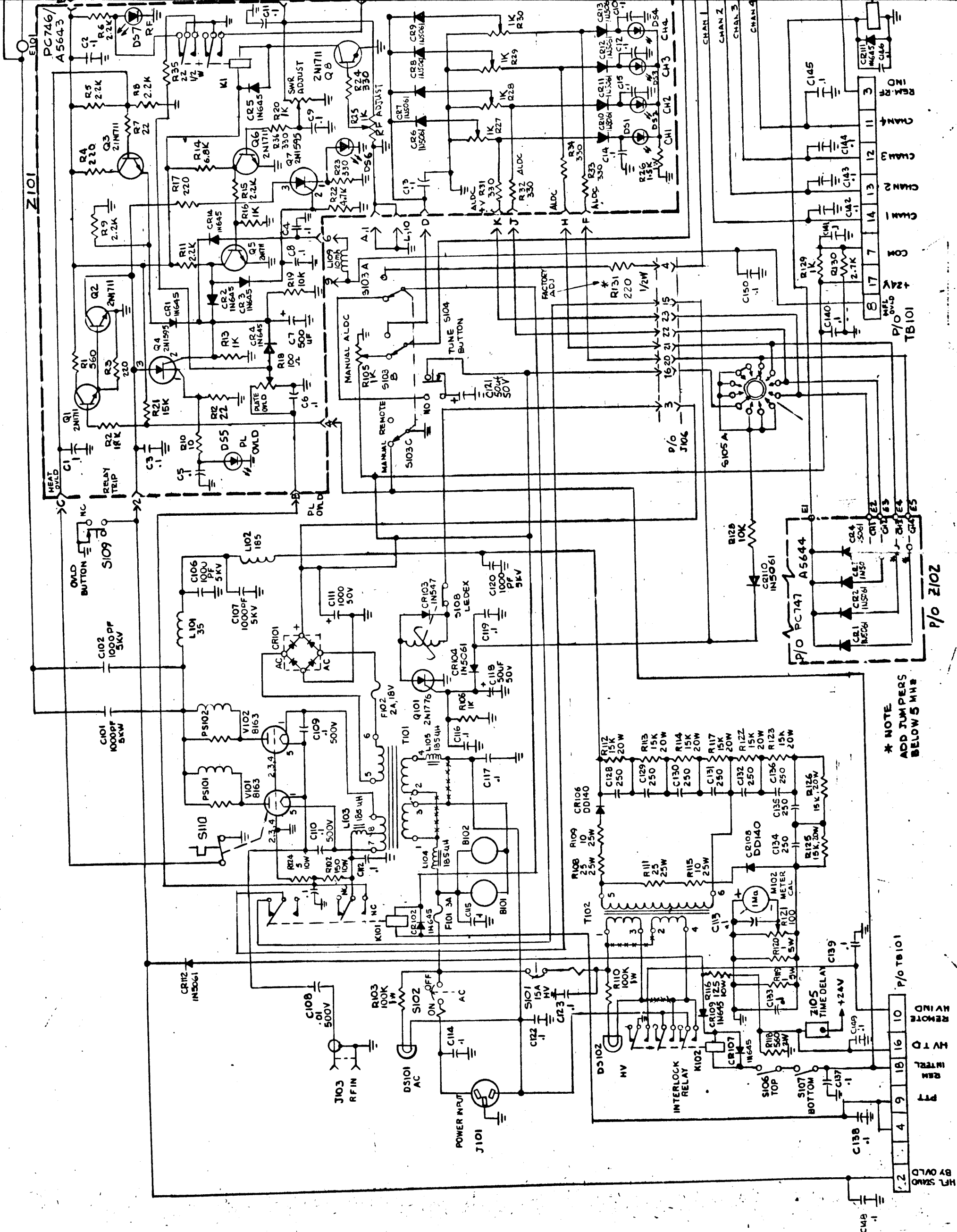

* NOTE:
ADD JUMPERS
BELOW 5 MHz

1/17
1/18

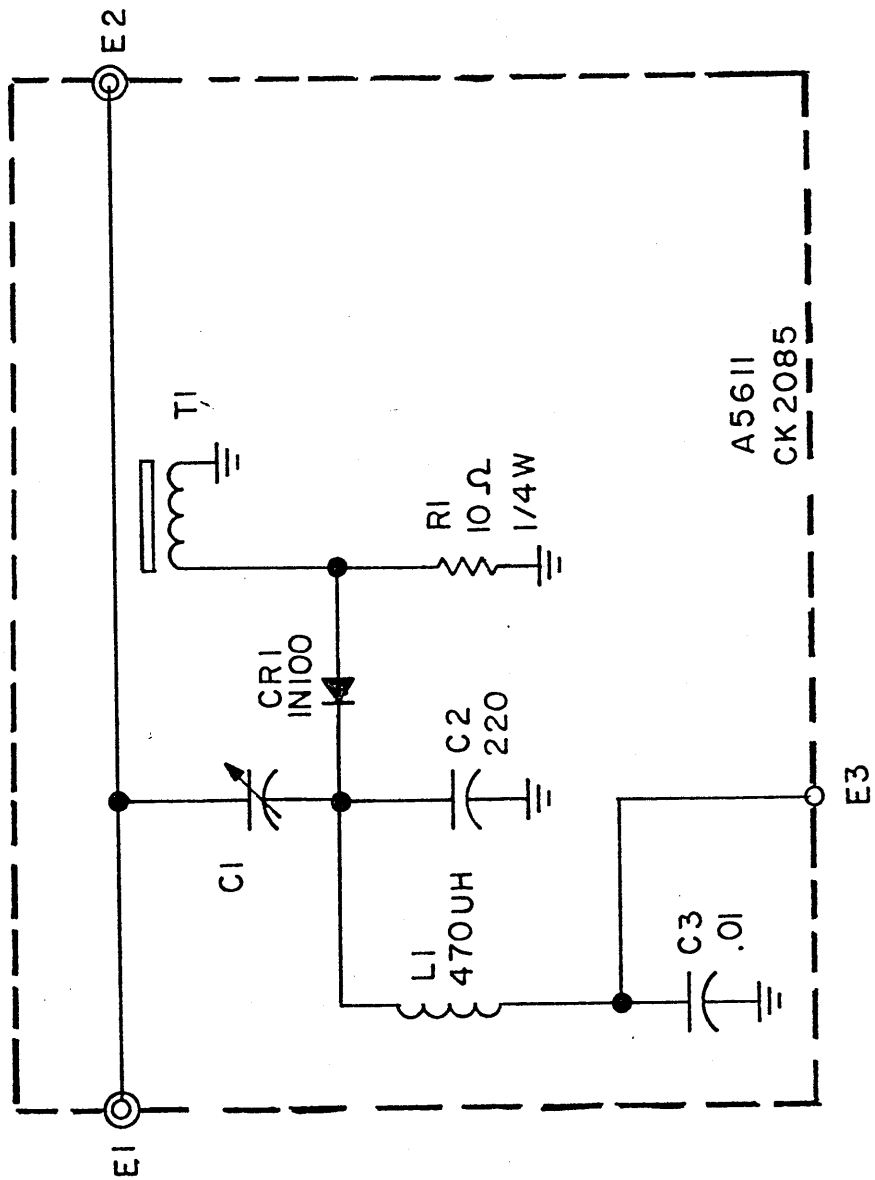

A5611
CK 2085

D.C. COUPLER

Figure 4-2

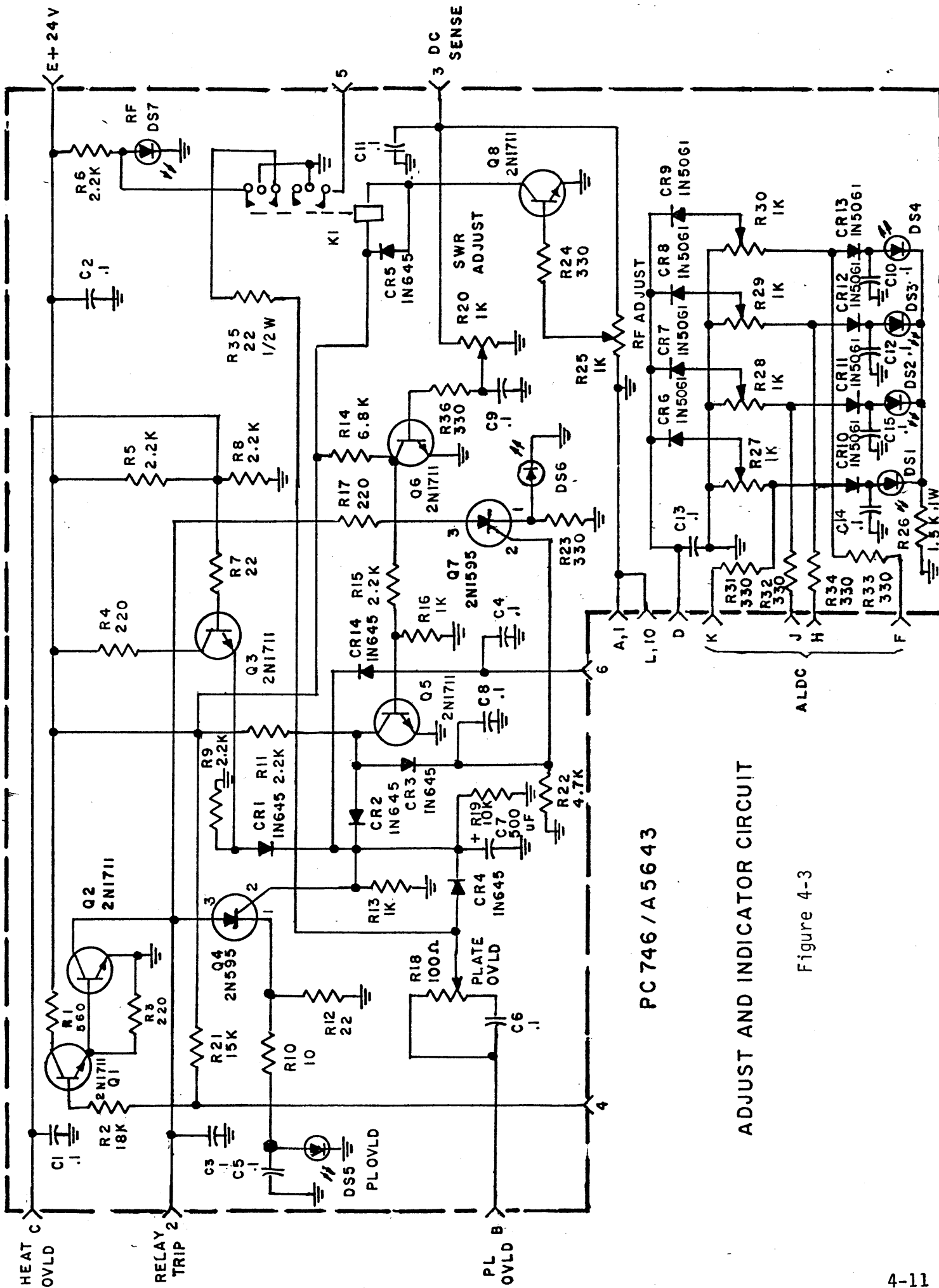

PC 746 / A5643

ADJUST AND INDICATOR CIRCUIT

Figure 4-3

SECTION 5
MAINTENANCE AND TROUBLE SHOOTING

5-1. GENERAL

The TMA-1KC linear power amplifier is designed to provide long-term, trouble-free operation under continuous duty conditions. Care on the part of the operator and attention to minor problems will do much to prevent unwarranted "down time". Regular inspection and cleaning should be scheduled. It is particularly important that the air path for the ventilating blowers be kept clean, and lint and dust-free.

5-2. PREVENTIVE MAINTENANCE

WARNING

Source power should be removed and the connector tagged before initiating inspection procedures.

At regularly scheduled intervals the TMA-1KC should be cleaned and inspected. A thorough visual inspection may save hours of test and troubleshooting by detecting a failing component before a breakdown occurs. The protective covers should be removed and the wiring and all components checked for evidence of deterioration. If corrosion, charring, discoloring or grease is evident, the condition should be corrected by cleaning or by replacing the component. Only the same or equivalent replacement parts should be used. Section 6 of this manual presents a list of components by part number and should be consulted when repairs are being made. Dust may be removed from printed circuit boards with a soft brush or low pressure (under 20 psi) compressed air. Grease may be removed using any good dry cleaning liquid but adequate ventilation must be provided.

WARNING

Avoid the prolonged inhalation of volatile solvent vapors, and prolonged solvent contact with the skin. Do not use such solvent in the presence of open flame, or spark producing equipment.

Check all electrical and mechanical connections for security, and repair any which may have become loose due to vibration or shock. Take particular care that all high voltage connections are electrically and mechanically secure and that the 8163 amplifier tubes are firmly seated in the sockets.

5-3. PERFORMANCE TESTS

At regularly scheduled intervals (at the very least every six months) or if a failure occurs, the TMA-1KC should be isolated from the equipment with which it is associated and the unit tested for proper operation. It is recommended that such a program be carried out only by a competent maintenance technician familiar with the equipment and with normal troubleshooting techniques. The only equipment required for such testing is a multimeter such as the Simpson Model 260, and a Vacuum Tube Voltmeter such as the Hewlett-Packard Model 410B to check the rf circuits.

Should a failure occur, the nature of the failure and logical reasoning should suffice to isolate the failure to a particular area or circuit. Several of the circuits can be tested without the application of high voltage.

As a safety precaution the operation of the unit with high voltage applied when both safety covers removed should be avoided. The technician must be familiar with the locations within the unit where high potentials may be encountered.

SECTION 6

PARTS LIST

The parts lists presented in this section provide a cross reference between the reference designation of the part and the TMC part number. The reference designation is used to identify a part on assembly drawings and schematic diagrams. Wherever practical, they are also marked on the equipment adjacent to the part.

The letter of the reference designator identifies the generic group to which the part belongs; eg: resistor (R), capacitor (C), switch (S).

Complete identification will expedite delivery when ordering renewal parts. The following information should be given for each part:

Description
*Reference designation
TMC part number
*Assembly number
Equipment model number
Equipment serial number

This information is available from the equipment nameplate, and the parts lists in this section.

To simplify the task of ordering renewal parts, an order form has been included at the end of this section. The information requested in the preceding list which has been marked with an asterisk should be included in the description column.

PARTS LIST

TMA-1KC

REF SYMBOL	DESCRIPTION	TMC PART NUMBER
B101	FAN AXIAL	BL106-5
B102	SAME AS B101	
C101	CAP, FXD, CER	CC109-38
C102	SAME AS C101	
C103	CAP, FXD, CER	CC109-7
C104		
C105	CAP, FXD, CER	CC131-39
C106	SAME AS C101	
C107	SAME AS C101	
C108	CAP, FXD, CER	CM112R103J5S
C109	CAP, FXD, CER	CC100-32
C110	SAME AS C109	
C111	CAP, FXD, ELECT.	CE116-8VN
C112	SAME AS C109	
C113	SAME AS C109	
C114	SAME AS C109	
C115	SAME AS C109	
C116	SAME AS C105	
C117	SAME AS C109	
C118	CAP, FXD, ELECT.	CE105-50-50
C119	SAME AS C105	
C120	SAME AS C101	
C121	SAME AS C118	
C122	SAME AS C109	
C123	SAME AS C109	
C124	CAP, AIR, VAR	CB175-3
C125	SAME AS C124	
C126	SAME AS C124	
C127	SAME AS C124	
C128	CAP, FXD, ELECT.	CE112-1
C129	SAME AS C128	
C130	SAME AS C128	
C131	SAME AS C128	
C132	SAME AS C128	
C133	SAME AS C109	
C134	SAME AS C128	
C135	SAME AS C128	
C136	SAME AS C128	
C137	SAME AS C105	
C138	SAME AS C105	
C139	SAME AS C105	
C140	SAME AS C105	
C141	SAME AS C105	
C142	SAME AS C105	
C143	SAME AS C105	
C144	SAME AS C105	

PARTS LIST (cont)

TMA-1KC

REF SYMBOL	DESCRIPTION	TMC PART NUMBER
C145	SAME AS C105	CC109-1
C146	SAME AS C105	
C147	CAP, FXD, CER	
C148	SAME AS C105	
C149	SAME AS C105	
C150	SAME AS C105	
C151	SAME AS C105	
CR101	RECT, SECOND, DEV.	DD142-1
CR102	SECOND, DEV, DIO.	1N645
CR103	SECOND, DEV, DIO.	1N547
CR104	SECOND, DEV, DIO.	1N5061
CR105		
CR106	DIO, RECF	DD140
CR107	SAEM AS CR102	
CR108	SAME AS CR106	
CR109	SAME AS CR102	
CR110	SAME AS CR104	
CR111	SAME AS CR102	
CR112	SAME AS CR104	
DS101	BULB, NEON	BI100-51
DS102	SAME AS DS101	
F101	FUSE, CTG. 3A	FU102-3
F102	FUSE, DTG. 2A	FU102-2
J101	CONN, RECP, ML	JJ175
J102	CONN, REC, P.C. BD.	JJ319A15DPE
J103	CONN.	UG625B/U
J104	SAME AS J103	
J105	CONN, RF	UG58A/U
J106	CONN, RECP	JJ310-2
K101	RELAY, ARM	RL116DC3C024
K102	SAME AS K101	
K103	RELAY, ARM	RL197
L101	COIL, RF, FXD.	CL166-2
L102	COIL, RF, FXD,	CL178
L103	SAME AS L102	
L104	SAME AS L102	
L105	SAME AS L102	
L106	COIL, RF	CL475-12
L107	COIL, TANK	CL118-22
L108	COIL, HIGH FREQ.	CL487
L109	COIL, RF	CL275-103

REF SYMBOL	DESCRIPTION	TMC PART NUMBER
M101 M102	METER, OUTPUT METER, IP	MR237-2 MR237-1
PS101 PS102	PARASITIC,SUPPRESSER SAME AS PS101	AX391
Q101	TRANSISTOR, SCR	2N1776
R101 R102 R103	RES, FXD, WW RES, FXD, COMP.	RW109-11 RC32GF104J
R104 R105 R106	RES, VAR, COMP. RES, FXD, COMP.	RV4ATRD102A RC32GF102J
R107 R108 R109	RES, FXD, WW RES, FXD, WW	RW111-6 RW111-4
R110 R111	SAME AS R103 SAME AS R108	
R112 R113	RES, FXD, WW SAME AS R112	RW110-35
R114 R115	SAME AS R112 SAME AS R109	
R116 R117	RES, FXD, WW SAME AS R112	RW109-10
R118 R119	RES, FXD, COMP. RES, FXD, WW	RC42GF561J RR114-1.5W
R120 R121	SAME AS R119 RES, VAR, COMP.	RV106UX10C101A
R122 R123	SAME AS R112 SAME AS R112	
R124 R125	RES, FXD, WW SAME AS R112	RW109-3
R126 R127	SAME AS R112	
R128 R129	RES, FXD, COMP. RES, FXD, COMP.	RC07GF103J RC07GF102J
R130 R131	RES, FXD, COMP. RES, FXD, COMP.	RC07GF272J RC20GF221J
R132	RES, FXD, COMP.	RC07GF682J
S101 S102	CIRCUIT BREAKER CIRCUIT BREAKER	SW461-1 SW461-2
S103 S104	SWITCH, ROTARY SWITCH, PUSHBUTTON	SW321 SW296-1
S105 S105	SWITCH, ROTARY LEDEX SWITCH, ROTARY	SW555 A5614

REF SYMBOL	DESCRIPTION	TMC PART NUMBER
S106 S107 S108 S109 S110	SWITCH, INTERLOCK SAME AS S106 SWITCH, ROTARY SWITCH, PUSHBUTTON SWITCH, HEAT SENSITIVE	SW219 SW562 SW296-2 SS100
T101 T102 T103	TRANSFORMER, POWER TRANSFORMER, POWER TRANSFORMER, MATCH	TF369-1 TF368 TR202
TB101	TERMINAL, STRIP	TM100-18
V101 V102	TUBE, ELECT. SAME AS V101	8163
XDF101 XDF102	FUSE HOLDER SAME AS XDF101	FH100-1
XDS101 XDS102	SOCKET, LIGHT IND. SOCKET, LIGHT IND.	TS106-2 TS106-1
XDV101 XDV102	SOCKET, TUBE ELEC. SAME AS XDV101	TS125-2
Z105	NETWORK TIME DELAY	NW183-30

PARTS LIST

Z101

REF SYMBOL	DESCRIPTION	TMC PART NUMBER
C1	CAP, FXD, CER	CC131-39
C2	SAME AS C1	
C3	SAME AS C1	
C4	SAME AS C1	
C5	SAME AS C1	
C6	SAME AS C1	
C7	CAP, FXD, ELECT.	CE116-10V
C8	SAME AS C1	
C9	SAME AS C1	
C10	SAME AS C1	
C11	SAME AS C1	
C12	SAME AS C1	
C13	SAME AS C1	
C14	SAME AS C1	
C15	SAME AS C1	
CR1	SCOND, DEV, DIO	1N645
CR2	SAME AS CR1	
CR3	SAME AS CR1	
CR4	SAME AS CR1	
CR5	SAME AS CR1	
CR6	SCOND, DEV, DIO	1N5061
CR7	SAME AS CR6	
CR8	SAME AS CR6	
CR9	SAME AS CR6	
CR10	SAME AS CR6	
CR11	SAME AS CR6	
CR12	SAME AS CR6	
CR13	SAME AS CR6	
CR14	SAME AS CR1	
DS1	LIGHT, EMIT, DIODE	BI-132
DS2	SAME AS DS1	
DS3	SAME AS DS1	
DS4	SAME AS DS1	
DS5	SAME AS DS1	
DS6	SAME AS DS1	
DS7	SAME AS DS1	
K1	RELAY	RL143-6S
R1	RES, FXD, COMP.	RC07GF561J
R2	RES, FXD, COMP.	RC07GF182J
R3	RES, FXD, COMP.	RC07GF221J
R4	SAME AS R3	
R5	RES, FXD, COMP.	RC07GF222J

REF SYMBOL	DESCRIPTION	TMC PART NUMBER
R6	SAME AS R5	
R7	RES, FXD, COMP.	RC07GF220J
R8	SAME AS R5	
R9	SAME AS R5	
R10	RES, FXD, COMP.	RC07GF100J
R11	SAME AS R5	
R12	SAME AS R7	
R13	RES, FXD, COMP.	RC07GF102J
R14	RES, FXD, COMP.	RC07GF682J
R15	SAME AS R5	
R16	SAME AS R13	
R17	SAME AS R3	
R18	RES, VAR, COMP.	RV111V101A
R19	RES, FIXD, COMP.	RC07GF103J
R20	RES, VAR, COMP.	RV126-61P-102
R21	RES, FXD, COMP.	RC07GF153J
R22	RES, FIXD, COMP.	RC07GF472J
R23	RES, FIXD, COMP.	RC07GF331J
R24	SAME AS R23	
R25	SAME AS R20	
R26	RES, FIXD, COMP.	RC07GF152J
R27	SAME AS R20	
R28	SAME AS R20	
R29	SAME AS R20	
R30	SAME AS R20	
R31	SAME AS R23	
R32	SAME AS R23	
R33	SAME AS R23	
R34	SAME AS R23	
R35	RES, FIXD, COMP.	RC20GF220J
R36	SAME AS R23	
Q1	TRANSISTOR	2N1711
Q2	SAME AS Q1	
Q3	SAME AS Q1	
Q4	TRANSISTOR	2N1595
Q5	SAME AS Q1	
Q6	SAME AS Q1	
Q7	SAME AS Q4	
Q8	SAME AS Q1	

PARTS LIST

Z102

REF SYMBOL	DESCRIPTION	TMC PART NUMBER
CR1 CR2 CR3 CR4 CR5 CR6 CR7 CR8	SCOND, DEV, DIO. SAME AS CR1 SAME AS CR1 SAME AS CR1 SAME AS CR1 SAME AS CR1 SAME AS CR1 SAME AS CR1	1N5061

PARTS LIST

Z103

REF SYMBOL	DESCRIPTION	TMC PART NUMBER
C1	CAP, FIXD, CER	CC100-29
C2	CAP, FIXD, CER	CC131-39
C3	CAP, FIXD, ELEC.	CE105-25-25
C4	SAME AS C2	:
C5	SAME AS C3	:
C6	SAME AS C2	:
C7	CAP, FIXED.	CM111E180J
CR1	SCOND, DEV, DIO	1N914
CR2	SAME AS CR1	
L1	COIL, RF	CL275-221
R1	RES, FXD, COMP.	RC07GF222J
R2	RES, FXD, COMP.	RC07GF102J
R3	RES, FXD, COMP.	RC07GF272J
R4	SAME AS R2	

PARTS LIST
DC COUPLER Z104

REF SYMBOL	DESCRIPTION	TMC PART NUMBER
C1	CAPACITOR, VARIABLE, AIR	A5612
C2	CAPACITOR, FIXED, MICA	CM111F221J1S
C3	CAPACITOR, FIXED, CERAMIC	CC100-43
CR1	SEMICONDUCTOR, DEVICE, DIODE	1N100 :
R1	RESISTOR, FIXED, COMPOSITION	RC07GF100J
T1	TRANSFORMER, RF	TZ236

REVISIONS							
REV. NO.	DRAFT	CHKD	ZONE	LTR	DESCRIPTION	DATE	APPROVED
1					C7 Leads Res Added Housing Clarified	2-14-76	

MOUNT C3 ON REAR OF BOARD

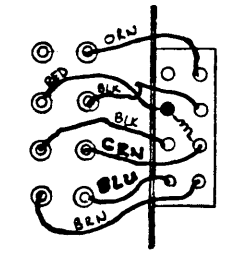
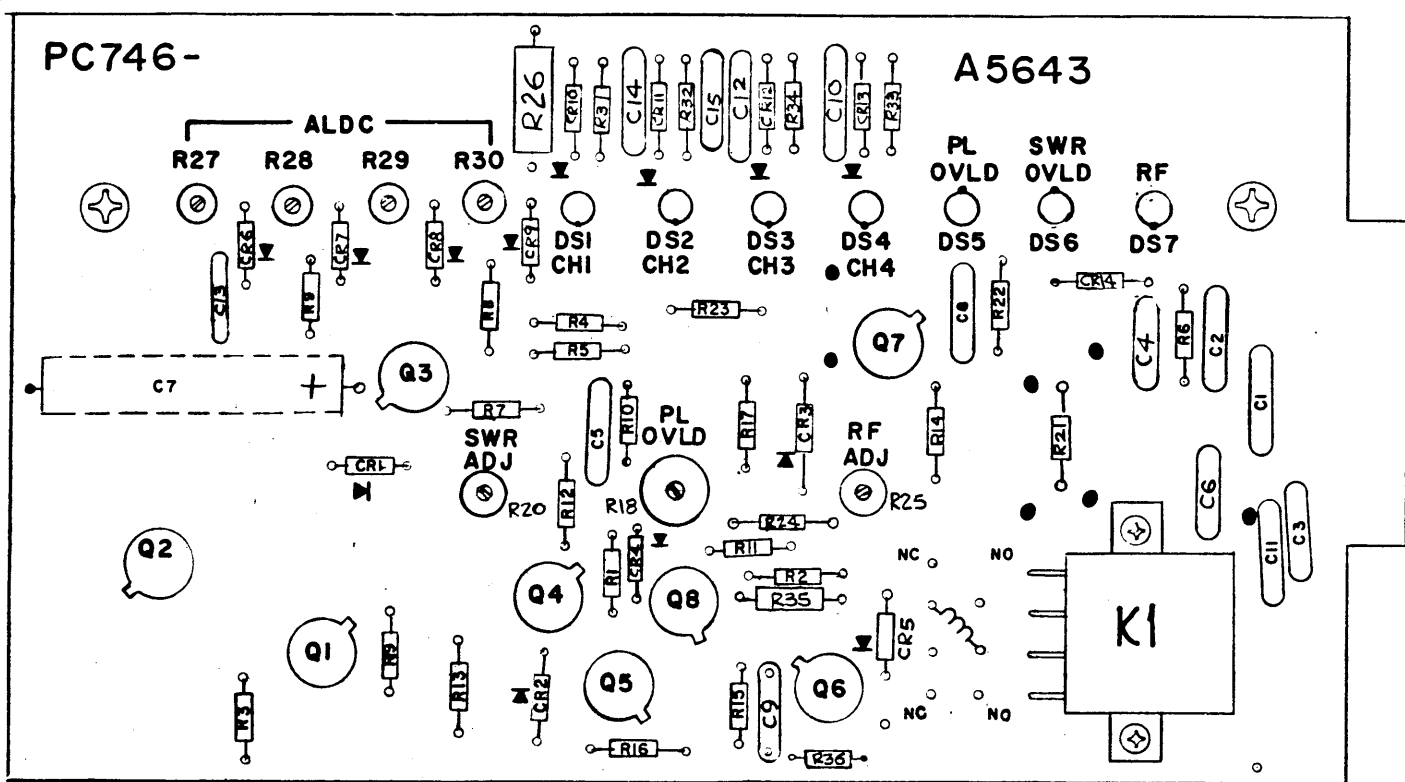
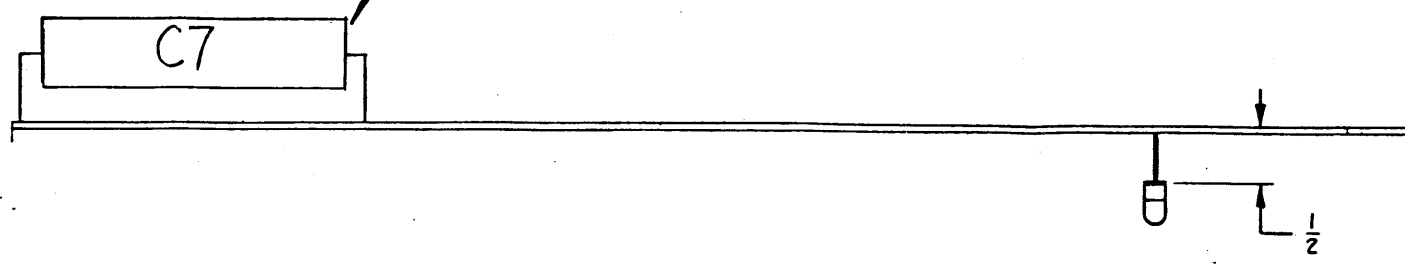

ASSEMBLY NOTES

1. TO MOUNT COMPONENTS INSERT LEADS THROUGH HOLES.
2. CAUTION, WHEN APPLYING HEAT & SOLDER TO LEAD & FOIL.
3. CLEAN & INSPECT AS PER SPEC S676.
4. FOR ELECTRICAL COMPONENT PART NUMBERS REFER TO NPL A
5. USE SYMBOL NUMBERS FOR ASSY. REF.

Z101

A5643
SCHEMATIC, DIAGRAM
COMPONENT LOCATION Z101

REF: CK213

TMA-1KC		
QTY / UNIT	MODEL USED ON	ASS'Y NO.
APPLICATION		
CODE		
MATERIAL		
FINISH		

NOTICE TO PERSONS RECEIVING THIS DRAWING
THE TECHNICAL MATERIAL CORPORATION claims proprietary right in the material disclosed herein. This drawing is loaned in confidence for engineering information only and may not be reproduced or used to manufacture anything shown herein without permission from THE TECHNICAL MATERIAL CORPORATION to the user. This drawing is loaned for mutual assistance and is subject to recall at any time.

UNLESS OTHERWISE SPECIFIED DIMENSIONS ARE IN INCHES AND INCLUDE CHEMICALLY ANNEALED OR PLATED FINISHES	
TOLERANCES ON	
DECIMALS	FRACTIONS
X = .05	= 1/16
XX = .01	ANGLE
XXX = .005	= 0° ±

Figure 6-1

5

4

3

2

1

REVISIONS							
EM.N. NO.	DRAFT	CHKD	ZONE	LTR	DESCRIPTION	DATE	APPROVED

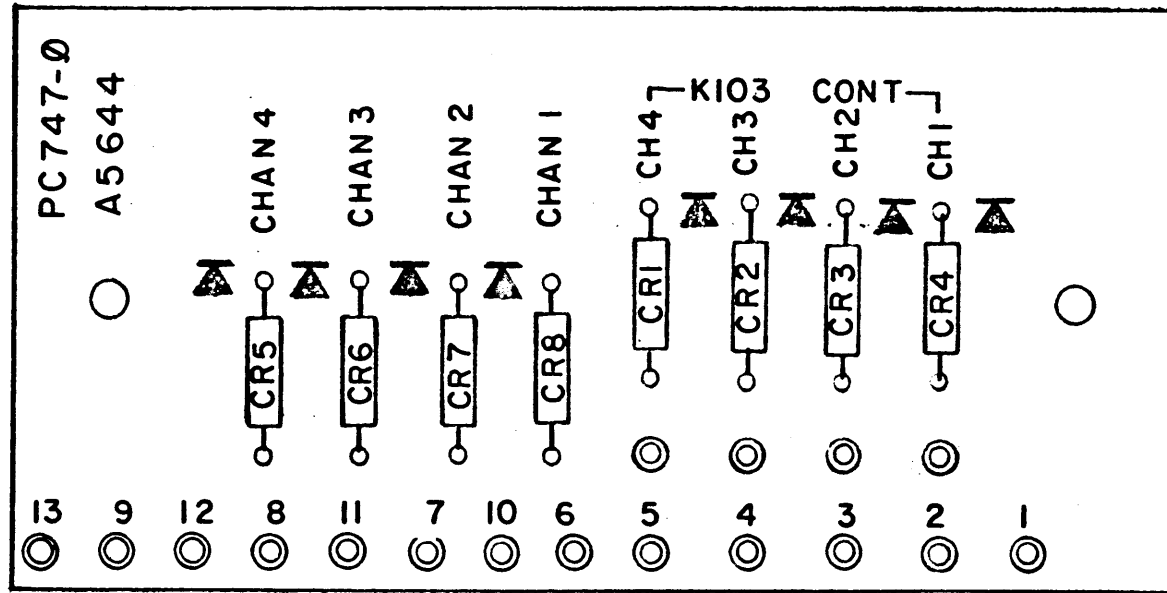

ASSEMBLY NOTES

1. TO MOUNT COMPONENTS INSERT LEADS THROUGH HOLES.
2. CAUTION, WHEN APPLYING HEAT & SOLDER TO LEAD & FOIL.
3. CLEAN & INSPECT AS PER SPEC S676.
4. FOR ELECTRICAL COMPONENT PART NUMBERS REFER TO NPL A
5. USE SYMBOL NUMBERS FOR ASSY. REF.

Z102

REQ'D	ITEM	PART NUMBER	DESCRIPTION	SYM.
X	2	BS100	SOLDER TIN ALLOY	
1	1	PC747	PRINTED CIRCUIT BD	

LIST OF MATERIAL

A5644
SCHEMATIC, DIAGRAM
COMPONENT LOCATION Z102

Figure 6-2

6-12

REF:CK2132

1	TMA-1KC	
QTY / UNIT	MODEL USED ON	ASS'Y NO.
APPLICATION		
	CODE	

NOTICE TO PERSONS RECEIVING THIS DRAWING
THE TECHNICAL MATERIEL CORPORATION claims proprietary right in the material disclosed hereon. This drawing is issued in confidence for engineering information only and may not be reproduced or used to manufacture anything shown hereon without permission from THE TECHNICAL MATERIEL CORPORATION to the user. This drawing is loaned for mutual assistance and is subject to recall at any time.

UNLESS OTHERWISE SPECIFIED DIMENSIONS ARE IN INCHES AND INCLUDE CHEMICALLY APPLIED OR PLATED FINISHES		FINAL APPROVAL	DATE
DECIMALS .X ± .05 .XX ± .01 .XXX ± .005		MECH. DES.	DATE
FRACTIONS 1/64 ANGLES 0° -30'		ELECT. DES.	DATE
MATERIAL		CHECKED	DATE
FINISH		DRAWN	DATE
		G.D.L.	10-23-76

REVISIONS							
ZONE	LTR	DESCRIPTION	DATE	E.M.N.NO	DRAFT	CHKD	APPD

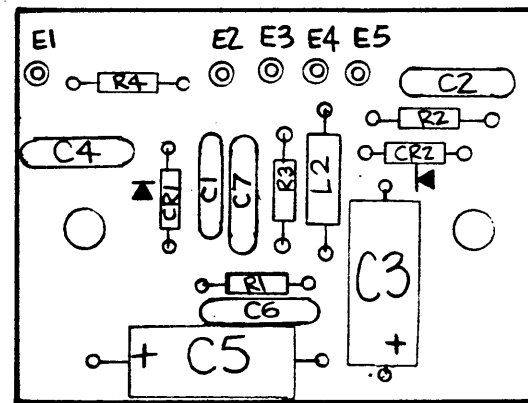

OUT HERE GUARANTEED 11-75
ASSEMBLY NOTES

1. TO MOUNT COMPONENTS INSERT LEADS THROUGH HOLES.
2. CAUTION, WHEN APPLYING HEAT & SOLDER TO LEAD & FOIL.
3. CLEAN & INSPECT AS PER SPEC S676.
4. FOR ELECTRICAL COMPONENT PART NUMBERS REFER TO NPL A
5. USE SYMBOL NUMBERS FOR ASSY. REF.

(CK2132)
 Z103

QTY. REQ.	ITEM	PART NO.	DESCRIPTION	SYMBOL
X	Z	BS100	SOLDER TIN ALLOY	
1	1	PC750	PRINTED CIRCUIT Bd	

1	TMAIKC	
QTY / UNIT	MODEL USED ON	ASS'Y NO.
APPLICATION		
	CODE	
<small>NOTICE TO PERSONS RECEIVING THIS DRAWING</small> <small>THE TECHNICAL MATERIEL CORPORATION claims proprietary right in the material disclosed hereon. This drawing is issued in confidence for engineering information only and may not be reproduced or used to manufacture anything shown hereon without permission from THE TECHNICAL MATERIEL CORPORATION to the user. This drawing is loaned for mutual assistance and is subject to recall at any time.</small>		

UNLESS OTHERWISE SPECIFIED
 DIMENSIONS ARE IN INCHES
 AND INCLUDE CHEMICALLY APPLIED
 OR PLATED FINISHES

TOLERANCES ON

DECIMALS	FRACTIONS
.X ± .05	± 1/64
.XX ± .01	ANGLES
.XXX ± .005	± 0°-30'

MATERIAL

FINISH

FINAL APPROV
 MECH. DES.
 ELECT. DES.
 CHECKED
 DRAWN

A5648
 SCHEMATIC, DIAGRAM
 COMPONENT LOCATION Z103

Figure 6-3