

TABLE OF CONTENTS

<u>Paragraph</u>		<u>Page</u>
<u>SECTION 1 - GENERAL INFORMATION</u>		
1-1	Functional Description	1-1
1-2	Physical Description	1-1
1-3	Reference Data	1-1
<u>SECTION 2 - INSTALLATION</u>		
2-1	Initial Unpacking and Inspection . .	2-1
2-2	Power Requirements	2-1
2-3	Initial Installation	2-2
<u>SECTION 3 - OPERATOR'S SECTION</u>		
3-1	General	3-1
3-2	Operating Controls	3-2
3-3	Preliminary Procedures	3-2
3-4	Operating Procedure	3-2
3-5	Operator Maintenance	3-8

LIST OF TABLES

<u>Table</u>		<u>Page</u>
1-1	Technical Specifications	1-2
1-2	Power Tube Complement	1-3
2-1	Terminal Board Connections	2-3
2-2	Rear Panel Connections	2-4
3-1	Front Panel Controls and Indicators .	3-1

LIST OF ILLUSTRATIONS

<u>Figure</u>		<u>Page</u>
1-1	General Purpose Linear Power Amplifier	1-0
2-1	115V to 230V Transformer Wiring Diagram	2-2
2-2	Interconnect Wiring Diagram	2-5
3-1	Controls and Indicators	3-0

SECTION 1
GENERAL INFORMATION

1-1. FUNCTIONAL DESCRIPTION

The general purpose linear power amplifier, Model TMA-1K shown in figure 1-1, was designed and manufactured by The Technical Materiel Corporation (TMC) of Mamaroneck, New York. The unit will supply 500 watts average or 1000 watts PEP (peak envelope power) output power over a frequency range of 2.0 to 30.0 MHz when provided with an input signal of 50 watts average power. A reliable automatic system controls a motor operated tuning network to completely tune the amplifier to the correct frequency, when band select information is provided to the automated band switch of the TMA-1K. This band select information may be supplied by the associated driving unit such as the model MMX(A)-2 exciter, or the correct band manually selected by operating a band select switch on the front panel. The amplifier is factory wired for operation from either a 115 or a 230 volt, 50/60Hz power source, as required by the specific installation.

1-2. PHYSICAL DESCRIPTION

The TMA-1K linear power amplifier is a compact, relatively light weight unit (approximately 55 lbs). It is completely solid-state with the exception of the two 8163 air-cooled amplifier tubes and protective relay. All of the controls and indicators are located on the 19 x 9 inch front panel (refer to figure 1-1). Protective fuses, and connectors for the input and output signals are located at the rear of the 18 inch deep chassis. The unit is designed for slide mounting in a standard equipment rack or cabinet. Panel locks and slide mount tracks are provided to position and secure the amplifier unit in the rack or cabinet.

1-3. REFERENCE DATA

Table 1-1 lists the technical specifications of the linear power amplifier, TMA-1K.

TABLE 1-1. TECHNICAL SPECIFICATIONS

FREQUENCY RANGE:	2.0 MHz to 30 MHz.
OPERATING MODES:	Capable of all standard modes of operation (CW, AM, AME, LSB, SSB, FAX, FSK), but dependent upon the capabilities of the exciter being used.
POWER OUTPUT:	1000 watts peak envelope power (PEP) or 500 watts average.
OUTPUT IMPEDANCE:	50 ohms, unbalanced.
STABILITY AND FREQUENCY CONTROL:	Capable of stability within 1 part in 10^8 but dependent upon the stability of the exciter being used.
TUNING:	Automatic or manual.
RF INPUT:	Provides 1000 watts PEP or 500 watts average output with an input of approximately 50 watts average power.
SPURIOUS SIGNALS:	At least 50 db down from the rated PEP output.
HARMONIC SUPPRESSION:	Second harmonic suppression better than 45 db with reference to full PEP output. Third and higher harmonics-better than 50 db below full PEP output.
HARMONIC FILTERS:	Available as an option, fixed for all frequencies above 30 MHz or band-switched for lower frequencies.
NOISE:	50 db down from rated PEP output.
COOLING:	Filtered forced air cooling.
ENVIRONMENTAL:	Designed to operate in any ambient temperature between the limits of 0 to 50 degrees centigrade for humidity up to 90 percent.
PRIMARY POWER:	115/230 vac, single phase, 50/60 Hz.

TABLE 1-1. TECHNICAL SPECIFICATIONS (cont)

POWER REQUIREMENTS:	Approximately 1,250 watts.
SIZE:	9 inches high x 19 inches wide x 18 inches deep.
INSTALLED WEIGHT:	Approximately 55 lbs.
SPECIAL FEATURES:	Overload protection, controlled and adjustable ALDC, and safety interlocks.

TABLE 1-2. POWER TUBE COMPLEMENT

<u>REFERENCE DESIGNATION</u>	<u>TYPE</u>	<u>FUNCTION</u>
V101*	8163	PA
V102*	8163	PA

*Operated in parallel

SECTION 2 INSTALLATION

2-1. INITIAL UNPACKING AND INSPECTION

The TMA-1K linear power amplifier was thoroughly tested at The Technical Materiel Corporation test facility in conjunction with an associated TMC equipment. Following successful completion of all operational tests, it was packed and crated together with the required cabling and connectors. Power tubes vulnerable to shipping damage are also separately packed. When the TMA-1K is a part of a TMC transmitter installation, all "loose items" (hardware, instruction manuals, connectors and the like) may be included in the transmitter package; however, all packing material should be carefully examined so that no items are overlooked.

The equipment should be carefully inspected at the installation site for indications of damage in transit. A claim should be filed with the carrier at once, if transit damage is discovered. The Technical Materiel Corporation will assist in rectifying such damage by recommending replacement parts and by describing repair methods.

2-2. POWER REQUIREMENTS

The TMA-1K linear power amplifier requires a single phase source of 115 or 230 volts, 50 or 60 Hz ac power. The equipment has been factory wired for use with the ultimate power supply indicated by the customer. If a decision is made to use an alternate power source, wiring change to the primary windings of T104 and T105 must be made to accommodate a change in voltage. Figure 2-1 shows the changes which are required. These changes should be made prior to installation.

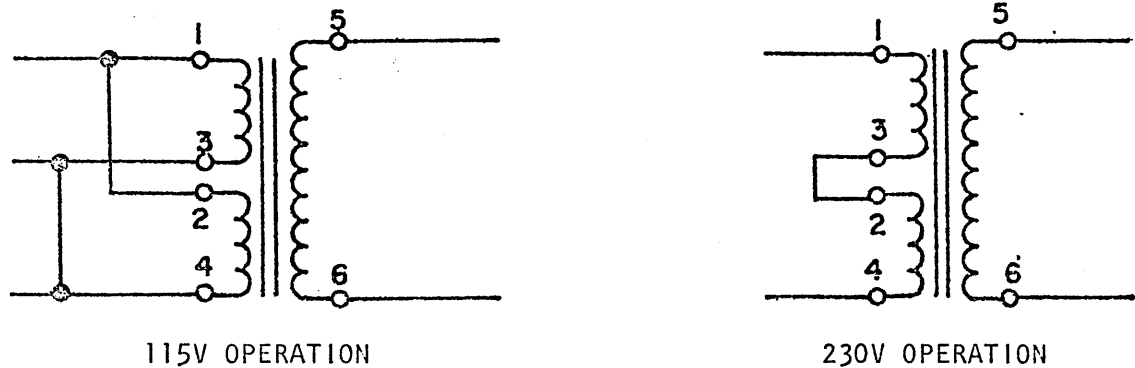

Figure 2-1. 115V to 230V TRANSFORMER WIRING DIAGRAM

WARNING

BE CERTAIN THAT THE UNIT IS CORRECTLY
WIRED BEFORE APPLYING PRIMARY POWER.

2-3. INITIAL INSTALLATION

The TMA-1K amplifier has been designed to be slide mounted in a standard equipment cabinet, and no special skill or instructions are necessary to fit the unit into place. The two 8163 power amplifying tubes (packed separately) must be reinstalled. Be sure that they are seated firmly in the sockets and make the plate connections to the top of the tubes with the hardware supplied. All the necessary electrical connections with associated equipment are made at the rear panel of the TMA-1K amplifier. The connectors on the rear panel are clearly marked and referenced in tables 2-1 and 2-2. Reference should also be made to the internal interconnect wiring diagram for the TMA-1K, figure 2-2. Connectors for any cable which must be fabricated by the customer are furnished as "loose items".

TABLE 2-1. TERMINAL BOARD CONNECTIONS

<u>TERMINAL NUMBER</u> (from left to right)	<u>CONNECTION</u>
1	Tune carrier
2	Drive up signal
3	Ready signal
4	Fault signal
5	Tune signal
6	Tune trigger delay
7	Bandswitch Trigger Voltage
8	24.0-30.0 MHz Band signal
9	16.0-24.0 MHz Band signal
10	12.0-16.0 MHz Band signal
11	8.0-12.0 MHz Band signal
12	5.0- 8.0 MHz Band signal
13	3.0- 5.0 MHz Band signal
14	2.6- 3.0 MHz Band signal
15	2.0- 2.6 MHz Band signal
16	1.5- 2.0 MHz Band signal
17	24 volt out
18	Remote interlock

NOTE

If a remote interlock is not used,
terminal 18 must be grounded to the
chassis.

D

C

B

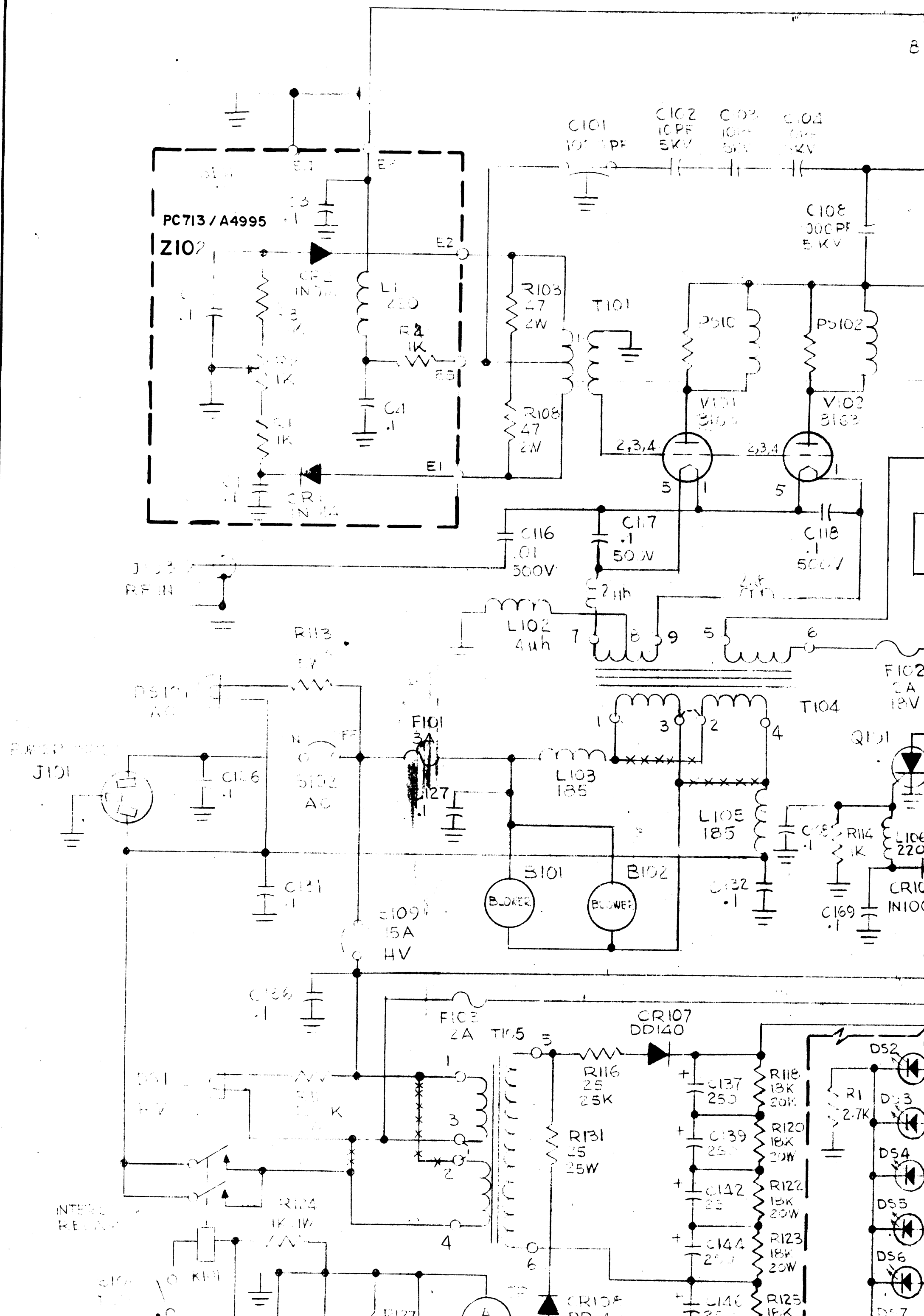

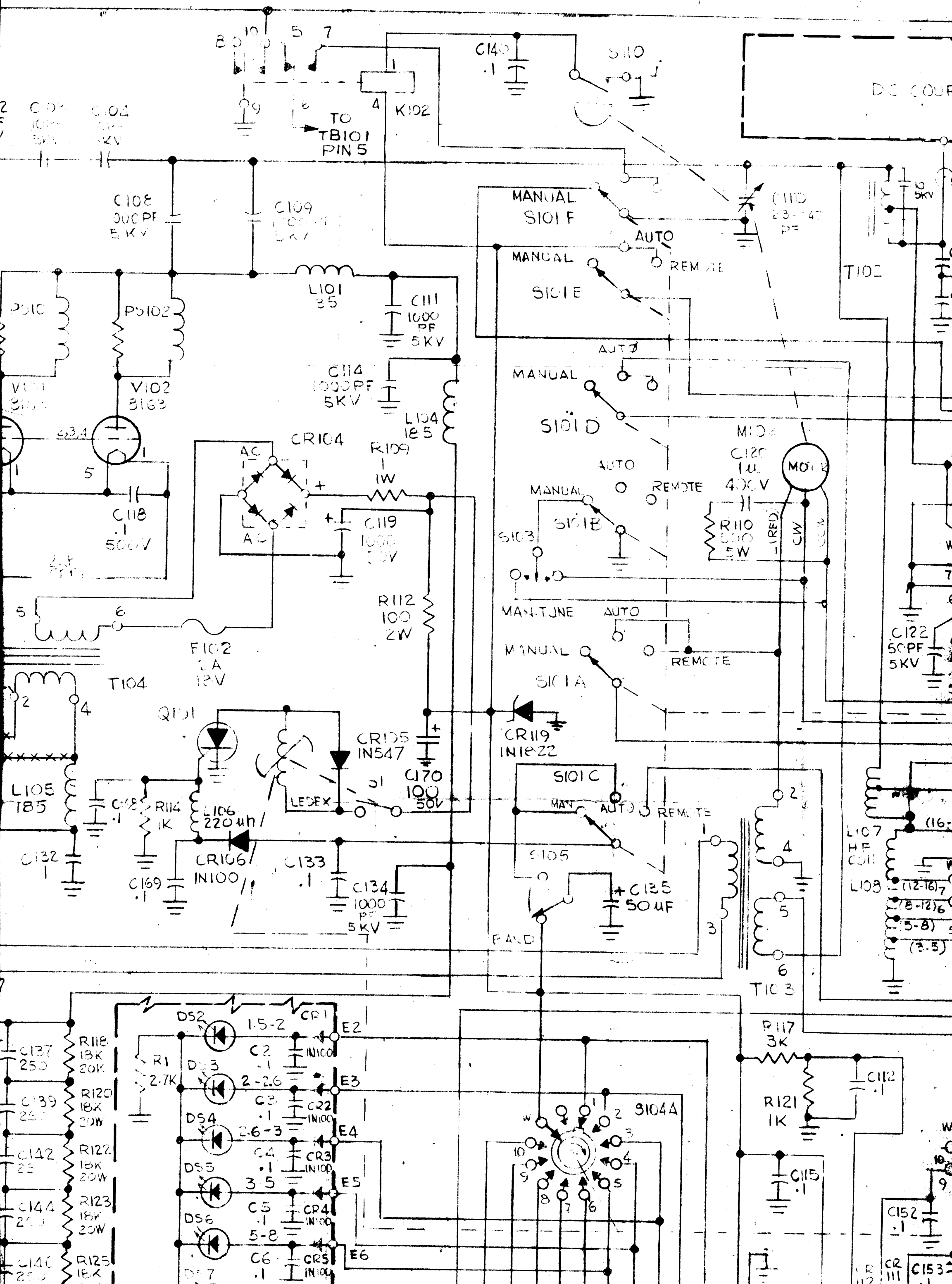

REVISION				DESCRIPTION	
E.M.N.NO	DRAFT	CHKD	ZONE	LTR	
				X1	...
				X2	...
				X3	...

DC COUPLER

J105
R.F. OUT

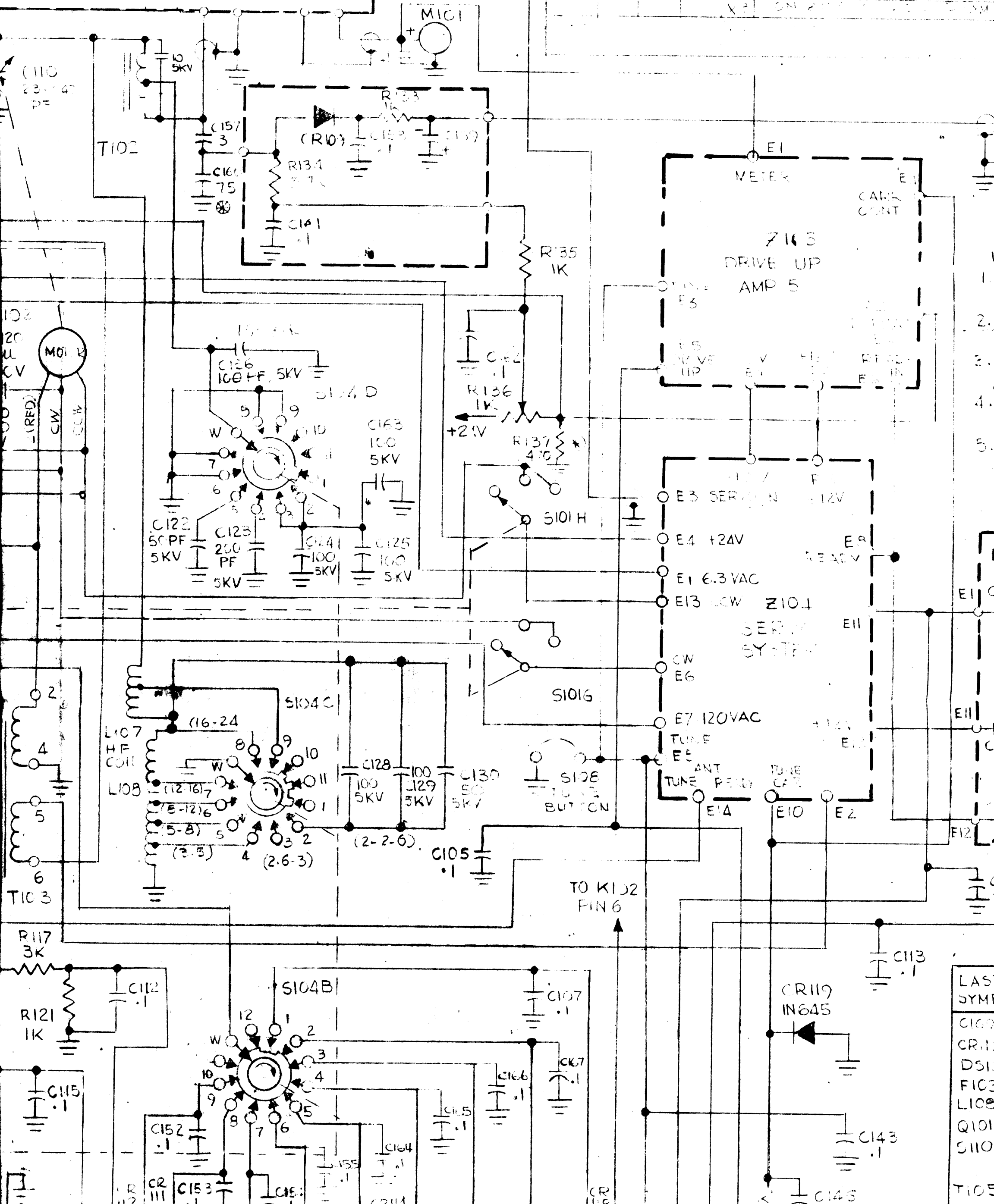

LAS
SYME
C160
CR11
DS1
FIC3
LICO
Q101
C110
T105

TABLE 2-2. REAR PANEL CONNECTIONS

<u>REFERENCE DESIGNATION</u>	<u>PANEL NOMENCLATURE</u>	<u>FUNCTION</u>
J101	PWR IN	AC power input.
J102	J102	Connects the TMA-1K to associated equipment (eg. antenna tuning system) to provide eight bandswitching signals.
J103	RF IN	RF signal input from associated driving units.
J104	ALDC	Connects automatic load and drive control to associated driving units.
J105	RF OUT	Connects rf output signal to associated antenna equipment.
TB101	TB101	Refer to table 2-1.

Also located on the rear panel of the TMA-1K amplifier are the protective fuses for the following circuits: Ac input (F101), tuning motor supply (F102) and control signal rectifier supply (F103).

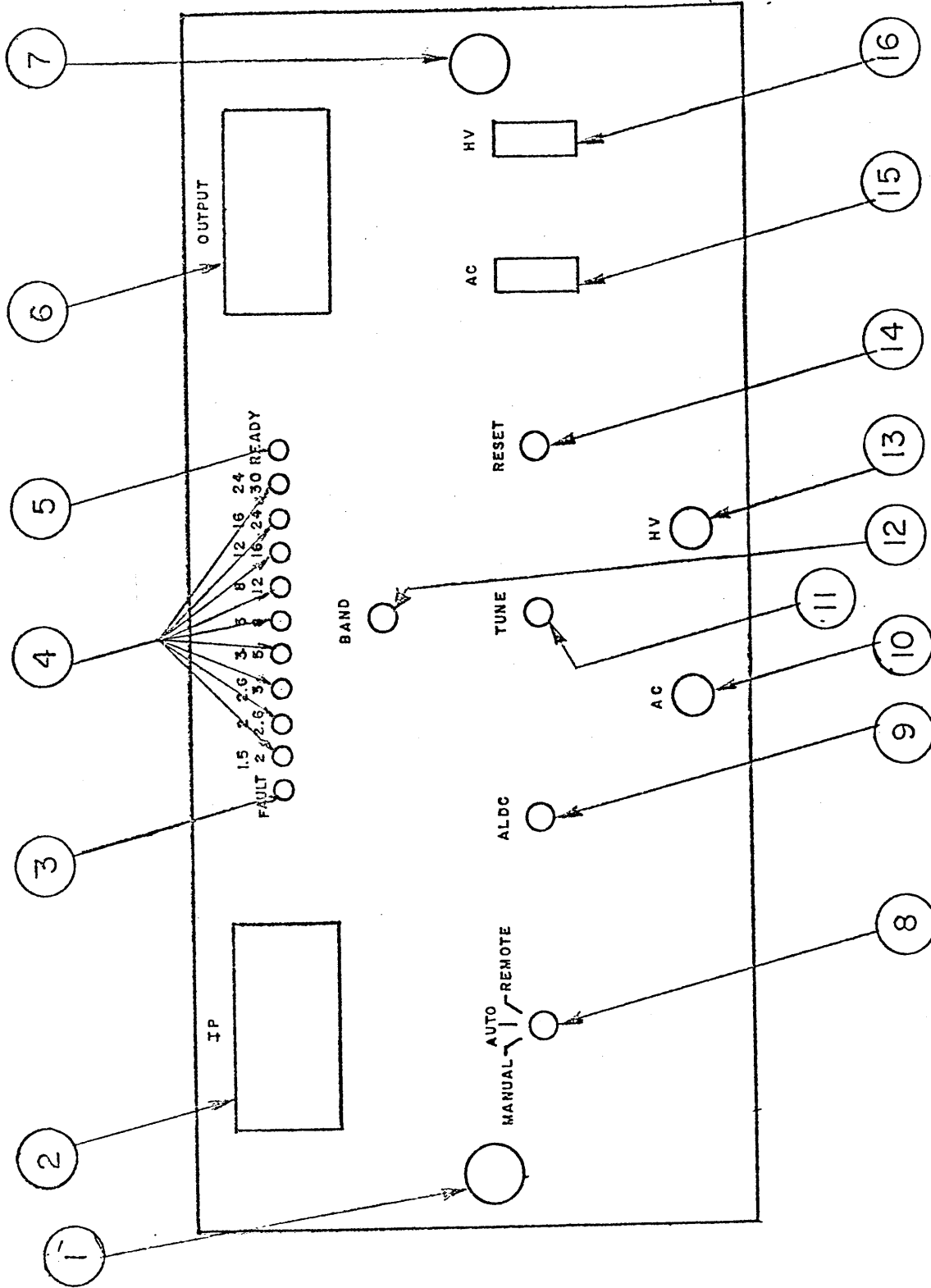

Figure 3-1. Controls and Indicators

SECTION 3
OPERATOR'S SECTION

3-1. GENERAL

The TMA-1K linear power amplifier will amplify an rf input signal of 50 watts average power to a 500 watt average, 1,000 watt PEP output signal. The TMA-1K will operate satisfactorily at any frequency in the 2.0 to 30.0 MHz range. In normal operation the amplifier is automatically tuned to the correct frequency but, if required, may be manually tuned.

3-2. OPERATING CONTROLS

All of the controls and indicators are located on the front panel illustrated in figure 3-1. They are functionally indentified in Table 3-1.

TABLE 3-1. FRONT PANEL CONTROLS AND INDICATORS (Refer to figure 3-1)

<u>INDEX NUMBER</u>	<u>PANEL NOMENCLATURE</u>	<u>NATURE AND FUNCTION</u>
1	NONE	Panel lock (LH) - Secures unit in cabinet.
2	IP	Milliammeter - Displays plate current.
3	FAULT	Indicator light (LED) - Indicates failure in tune cycle.
4	Band Numbers	Indicator lights (LED) - Indicate frequency band to which amplifier is tuned.
5	READY	Indicator light (LED) - Indicates amplifier is properly tuned.
6	OUTPUT	Milliammeter - Displays output power (average) in watts.
7	NONE	Panel lock (RH) - Secures unit in cabinet.
8	MANUAL-AUTO-REMOTE	Selector switch - Selects operating mode.
9	ALDC	Potentiometer - Controls ALDC feedback voltage to exciter.

TABLE 3-1. FRONT PANEL CONTROLS AND INDICATORS (Refer to figure 3-1) (cont)

<u>INDEX NUMBER</u>	<u>PANEL NOMENCLATURE</u>	<u>NATURE AND FUNCTION</u>
10	AC	Indicating lamp - When lighted indicates AC power is applied.
11	TUNE	Lever switch - Controls direction of tune motor when tuning manually.
12	BAND	Pushbutton - Controls bandswitch when selector switch (8) is set to MANUAL or AUTO.
13	HV	Indicator lamp - Indicates the application of high voltage.
14	RESET	Pushbutton - Resets automatic tune sequence.
15	AC	Circuit breaker - Controls line power input.
16	HV	Circuit breaker - Controls primary power to high voltage transformer.

3-3. PRELIMINARY PROCEDURES (Refer to figure 3-1.)

Before connecting the TMA-1K amplifier to any power source make certain that the ac power switch (15) and the high voltage switch (16) are in the off (down) position, and that the operational mode selector switch (8) is in the REMOTE position if amplifier tuning is to be controlled by the associated drive unit (exciter). Also be sure that the TMA-1K is securely mounted, and that all interconnections have been properly made.

3-4. OPERATING PROCEDURES

a. GENERAL. Usually the TMA-1K linear power amplifier serves a component of a TMC transmitter system, and detailed operating procedures are given in technical manual for the system in relation to other system components. Here, the amplifier is treated as a separate entity but of necessity reference is made to other system components.

b. MANUAL OPERATION. (Refer to figure 3-1.)

- (1) Connect the power source to J101.

CAUTION

The output circuit must be connected to an antenna system or suitable resistive (50 ohm), 1KW dummy load through output jack (J104) before power is applied.

- (2) Set selector switch (8) to the MANUAL position.

CAUTION

Make sure that no input signal is applied to the RF IN jack (J103) prior to switching on the high voltage.

- (3) Set the AC switch (15) to the on (up) position. AC indicator lamp (10) lights. Band indicator (4) lights. One minute time delay circuit is activated.

- (4) Press BAND pushbutton (12) sequentially until band indicator (4) shows that the proper tuning band has been selected for the frequency of the rf input signal to be used.

- (5) After one minute set HV switch (16) to the on (up) position. HV indicator lamp (13) lights. Plate current meter (2) indicates 200 ma.

- (6) Supply an rf signal to the amplifier from the associated equipment to J103 (RF IN).

(7) Increase the rf signal strength until an indication of plate current is observed on the IP meter (2) (approximately 250 ma).

CAUTION

Do not allow plate current to exceed 300 ma until tuning is complete.

(8) Using the TUNE lever switch (11) operate the tune motor until the highest possible indication (peak) is observed on the OUTPUT meter (6).

NOTE

A peak reading on the OUTPUT meter (6) should be accompanied by a decrease (dip) in the magnitude of the plate current as indicated on the IP meter (2). The amplifier is now tuned for the rf input frequency.

(9) Increase the amplitude of the rf input signal until full output of 500 watts is achieved. The plate current indicated on the IP meter (2) should be 400 - 550 ma depending on the frequency. This completes the manual tuning procedure.

c. AUTOMATIC OPERATION. (Refer to figure 3-1.)

(1) Connect the power source to J101.

CAUTION

The output circuit must be connected to an antenna system or suitable resistive (50 ohm) 1KW dummy load through output jack (J104) before power is applied.

(2) Set selector switch (8) to the AUTO position.

CAUTION

Make sure that no input signal is applied to the RF IN jack (J103) prior to switching on the high voltage.

(3) Set the AC switch (15) to the on (up) position. AC indicator lamp (10) lights. Band indicator (4) lights. One minute time delay circuit is activated.

(4) Press BAND pushbutton (12) sequentially until band indicator (4) shows that the proper tuning band has been selected for the frequency of the rf input signal to be used.

(5) After one minute set HV switch (16) to the on (up) position. HV indicator lamp (13) lights and IP meter (2) indicates 200 ma.

(6) Supply an rf signal to the amplifier from the associated equipment to J103 (RF IN).

(7) Increase the rf signal strength until an indication of plate current is observed on the IP meter (2).

CAUTION

Do not allow plate current to exceed 300 ma until tuning is complete.

(8) Initiate the automatic tuning cycle by pressing the RESET pushbutton (14).

(9) Observe that READY indicator lights when the amplifier is tuned for peak output.

NOTE

A maximum reading on the OUTPUT meter (6) should be accompanied by a decrease (dip) in the magnitude of the plate current as indicated on the IP meter (2). The amplifier is now tuned for the rf input frequency.

(10) Increase the amplitude of the rf input signal until the full output of 500 watts is achieved. The plate current (as indicated on the IP meter (2) is 400 - 550 ma depending on frequency. This completes the automatic tuning procedure.

- d. REMOTE OPERATION. (Refer to figure 3-1.)
(1) Connect the power source to J101.

CAUTION

The output circuit must be connected to an antenna system or suitable resistive (50 ohm) 1 KW dummy load through output jack (J104) before power is applied.

- (2) Set selector switch (8) to the REMOTE position.

CAUTION

Make sure that no input signal is applied to the RF IN jack (J103) prior to switching on the high voltage.

- (3) Be certain that the associated equipment (source of the band switching signal) is properly connected to TB 101 at the rear of the amplifier.

(4) Set the AC switch (15) to the on (up) position. AC indicator lamp (10) lights. One minute time delay circuit is activated. Bandswitch rotates to the correct position for the selected frequency and associated band indicator (4) lights.

(5) After one minute set HV switch (16) to the on (up) position. HV indicator lamp (13) lights and IP meter (2) indicates 200 ma.

(6) Supply an rf signal to the amplifier from the associated equipment to J103 (RF IN).

(7) Increase this rf signal strength until an indication of plate current is observed on the IP meter (2).

CAUTION

Do not allow plate current to exceed
300 ma until tuning is complete.

(8) Initiate the automatic tuning cycle by pressing the RESET pushbutton (14).

NOTE

The auto-tune system of the amplifier will automatically position the tuning elements to obtain a resonant condition for the specific input signal frequency with respect to the antenna system.

(9) Observe that READY indicator lights when amplifier is tuned for peak output.

NOTE

A maximum reading on the OUTPUT meter (6) should be accompanied by a decrease (dip) in the magnitude of the plate current as indicated on the IP meter (2). The amplifier is now tuned for the rf input frequency.

(10) Increase the amplitude of the rf input signal until a full output of 500 watts is achieved. The plate current (as indicated on the IP meter (2) is 400 - 550 ma depending on frequency. This completes the remotely controlled tuning procedure.

3-5. OPERATOR MAINTENANCE

The operator performed maintenance on the TMA-1K amplifier consists mainly of cleaning and the replacement of blown fuses or power tubes. Internal inspection of the unit and the replacement of worn or damaged parts should be a part of the regularly scheduled preventive maintenance program of the equipment of which the TMA-1K is a component.

TMC SPECIFICATION

NO. S1373

REV:

COMPILED:

CHECKED:

APPD:

SHEET

2

OF

2

TITLE:

TMA-1K TUNING CHART

<u>FREQ. MHz</u>	<u>Ip</u>	<u>KW OUTPUT</u>
2		
4		
6		
8		
12		
15		
18		
22		
24		
28		