

Power and Protection for Modern Tetrodes

Ian White, G3SEK

Tetrode power amplifiers are coming back into fashion, after many years in which US amplifier builders have focused almost exclusively on triodes. The situation in Europe has been very different, because tetrodes never went away. In particular, there have been many developments in tetrode power supply designs that US amateurs have missed – a situation which this article aims to rectify.

There's a great temptation to think of a tetrode as "a triode with an extra grid", and to treat the screen-grid supply as a minimal afterthought. That's a big mistake! The screen grid of a large transmitting tetrode has very specific needs, and if these are met the tube will reward you with excellent linearity on SSB. The screen current meter will show you whether the tube is tuned and loaded correctly, and a power supply that continuously monitors the screen current can protect the whole amplifier from a wide range of faults.

This article describes a modern stabilized screen-grid power supply that provides adjustable voltage and excellent dynamic regulation. It also includes very effective circuits to protect the tube and the rest of the amplifier. Although many of these circuit ideas may be new to you, they have been widely used for several years in Britain and the rest of Europe. With some adaptation to meet different requirements for screen voltage and current, they can be used as a 'drop-in' upgrade for almost any existing tetrode PA.

I will begin by explaining why it's a good idea to stabilize the screen voltage, to a much higher standard than has been regarded as normal (at least in the USA). It isn't difficult, and there are several good reasons for doing it.

DC Stability

The most basic reason for stabilizing the screen voltage is to achieve DC operating stability for the tube. The screen current in many tetrodes can be either positive or negative, in both normal and fault conditions, and this creates unusual requirements for the screen power supply. In normal operation, some of the electrons flowing from cathode to anode inside the tube are intercepted by the screen grid and flow outwards to the screen supply; this is observed as a positive screen current flowing into the tube (Fig 1a). However, the electron beam striking the screen grid will also result in secondary emission of electrons from the surface of the grid, especially when the anode voltage is swinging very high because the tube is lightly loaded. Electrons leaving the screen grid and joining the main cathode-anode flow will be observed as a negative screen current coming out of the tube (Fig 1b). Here's where trouble can start, because the reverse current is dumped back into the screen supply, and tends to drive the voltage upwards. The higher screen voltage leads to more secondary electron emission, which in turn leads to even higher voltage and a runaway situation that can end in serious damage. That is why a screen supply **must always** have the capability to absorb negative screen current without allowing the voltage to increase appreciably. The old-fashioned way to do this was by bleeding a generous standing current to ground¹ through a resistor (Fig 2a), so that the bleed current swamps any changes in voltage caused by the screen current. This circuit can absorb negative screen current but it has no voltage regulation at all. The next step forward was to stabilize the screen voltage using VR tubes, later replaced by zener diodes (Fig 2b), and that's as far as most tetrode power supplies have ever progressed.

At this point it's interesting to take a sideways look at the radically different power supply arrangement of Fig 3. This circuit was used by the Collins company with great success, in the 30S-1 amplifier for the amateur market and also in many other commercial linear amplifiers. None of the voltages is 'formally' regulated at all, but there are two separate high-current supplies, one for the anode and another for the cathode/screen. This means that any variations in screen current are swamped by the much larger variations in cathode current. In addition, both the anode and the cathode/screen supplies in the 30S-1 used choke-input filtering, which gives better voltage regulation than today's capacitor-input supplies, and this helped to prevent the operating point from wandering around under dynamic modulation conditions. As authors from the Collins company explained², if no voltages are stabilized, any variations in the mains voltage will change all the supply voltages in the same proportion, so the zero-drive current of the tube hardly changes. Unfortunately this approach is not as simple as it seems, for the Collins authors also made it very clear that if the control-grid bias is stabilized, the screen-grid voltage needs to be stabilized too – a point that a succession of later designers missed when they tried to 'borrow' selected features from the 30S-1 without realizing that it's an all-or-nothing deal. Today, there are better ways to achieve DC stability in tetrode amplifiers, involving a little more electronics but much less heavy iron.

A final point in favor of improving the DC stability is that secondary electron emission from the screen of many tetrodes tends to increase with time. Older tubes may not be usable in amplifiers that have poor screen regulation, because of the runaway effect described earlier. With a power supply that takes a very tight grip on the screen voltage, you can often continue to use these tubes for hundreds of hours more.

Reduced IMD

As the *ARRL Handbook* points out³, "The power output from a tetrode is very sensitive to screen voltage, and any dynamic change in the screen potential can cause distorted output. In a linear amplifier, the screen voltage should be well regulated for all values of screen current." But how well regulated does the screen voltage need to be? The answer will depend partly on the type of tetrode that you're using, but mostly on the standards you're setting for low intermodulation distortion (IMD). The screen supplies described in this article were designed to meet the exacting standards of European VHF DXing and contesting. Compared with HF, background noise levels at VHF are much lower, yet worst-case signal strengths between local stations using stacked arrays of long yagis can be very much higher. In an IARU Region 1 two-meter contest, "kilowatt alley" covers most of western Europe! As well as testing the dynamic range of receivers to the limit, these operating conditions place extreme demands on the IMD suppression of transmitters – demands that are reinforced by tough contest rules against persistent poor-quality transmissions.

Traditionally amateurs measure IMD by on-air tests, listening to each other's signals, and also by two-tone testing. Informal on-air tests seem less respectable than two-tone tests using laboratory equipment, yet in many ways they are more meaningful because they exercise the whole amplifier – including the power supply – under realistic modulation conditions. A normal two-tone test hardly exercises the power supply at all. The meters never move, so even an amplifier with totally unregulated power supplies can produce good-looking IMD performance in this essentially static test. Real-life speech modulation tells a very different story. If you have access to a modern digital spectrum analyzer, a very revealing test is to set the analyzer into 'peak hold' mode and simply start talking into the microphone. In the course of a few minutes a very broad IMD spectrum will build up, as the analyzer records even the transient peaks of 'splatter'. Unlike the static two-tone test, a peak-hold test is likely to reveal high-order IMD extending far out on either side of your main signal – as your neighbors on the band may already know! The difference from the static two-tone test is that real speech

exercises the dynamic regulation of your power supplies over a wide range of audio frequencies, from about 3kHz all the way down to the powerful syllabic pulses at a few hertz. It's very simple to improve the regulation at 500Hz–3kHz by connecting a large reservoir capacitor across the output of the screen supply; that's an easy way to make a two-tone test look good, but the capacitor has no effect down there at syllabic frequencies.

John Nelson, GW4FRX has been a constant campaigner for cleaner signals, and has been responsible for many key developments in tetrode power supplies^{4, 5, 6}. In particular he has carried out many series of two-tone IMD tests on 4CX250 and 4CX350 amplifiers, and more recently peak-hold tests as well. The first major conclusion is that better screen voltage regulation gives significantly better IMD performance, especially for the higher-order products that make your signal 'wide'. Fig 4 shows the IMD performance of a pair of 4CX250Rs in class AB1 at 500W PEP output, with three different types of screen supply. The best IMD performance comes from GW4FRX's own extremely well regulated supply. Second best is that same supply with a 150Ω series resistor added to artificially increase the output impedance. A poor third – especially for higher-order IMD – is the traditional 'chain of zeners' stabilizer with a parallel reservoir capacitor. The second major conclusion is that improved screen stabilization can give IMD performance that is notably better than stated in the Eimac data sheets. On the air, these conclusions have been verified by many British and European stations. Tight screen voltage regulation really does make a difference to your reputation!

Effective Protection

The next reason for paying close attention to the screen supply is that it can protect the whole amplifier. Almost anything wrong in a tetrode power amplifier will result in incorrect screen current. The range of faults that can be detected by monitoring the screen current includes: incorrect plate-circuit tuning; loading too light, or too heavy; excessive drive; loss or major change in anode, screen or control grid voltage; high-voltage RF and DC arcs, flashovers and other 'glitches'; and even overheating. All of these faults will result in too much screen current, either positive or negative. Using the protection circuit described later in this article, I've been able to keep the same pair of 4CX250Bs delivering 1kW output on 432MHz moonbounce for more than ten years. If the circuit hadn't worked well and reliably, the tubes would have been destroyed several times over.

That's enough philosophy. I hope I've convinced you that improved screen supplies can bring major benefits, so now let's get down to some circuits.

Shunt Regulator Basics

Because of the need to handle negative screen current, all screen voltage supplies **must** have a DC path to ground¹. In other words they need to be shunt regulators rather than series regulators⁷. Fig 5 recalls the basic shunt regulator configuration, a potential divider with a resistor R1 from the unregulated supply to the screen, and some kind of constant-voltage circuit from screen to ground.

Let's look at the current-flow budget in a shunt stabilizer. The current that flows through R1 is almost the same under all conditions; what varies is the fraction of the total current that is either delivered to the screen grid or shunted to ground through the voltage stabilizer. The unregulated supply and R1 must be capable of delivering the maximum positive screen current required by the tube, but the current also needs to be limited to protect the screen from excessive dissipation. The current that bleeds to ground through the voltage stabilizer must always be greater than the maximum positive screen current that the tube ever requires; otherwise the screen voltage will sink with excessive current demand. Also the stabilizer element must be capable of sinking the maximum negative screen current that the tube ever

generates, plus the bleeder current provided to handle with positive current demands. If the stabilizer can't handle all this extra current, it will allow the screen voltage to rise, which can lead to the runaway effect.

In an SSB amplifier the peak positive and negative screen currents can occur at unexpected points in the speech modulation waveform. Screen current will be close to zero with no drive, but in some tetrodes the current may peak negatively at moderate drive levels, then pass through zero again with increasing drive, and finally reach a positive peak. In other tetrodes, screen current may peak almost exclusively in the negative region, except at very high drive levels. These negative and positive variations can occur within a single audio cycle, and the screen current meter cannot follow them. Large positive and negative current swings may average out to almost zero on the meter, and can lead you to assume that there are no real demands on the power supply – but if the screen voltage drops out of regulation for even an instant, your neighbors will know it!

What's wrong with conventional chains of VR tubes or zener diodes in regulated screen supplies (Fig 2b)? VR tubes have a very significant dynamic impedance – the ratio of (voltage variation)/(current variation) – and this effect is cumulative when devices are connected in series to obtain the required total voltage. A typical series string of two VR105s and a VR150 has a dynamic impedance of about 500Ω. Unfortunately high-voltage zener diodes are not much better than VR tubes, so either type of stabilizer may allow the screen supply to swing by several volts when the screen current changes by plus-or-minus about 10mA. Passive devices for screen-voltage regulation are hardly adequate, as the IMD spectra in Fig 4 clearly show.

For excellent voltage regulation that will allow the tube to develop its optimum IMD performance, the solution is to use an active feedback regulator. The next question is to find the right level of circuit complexity, namely the simplest circuit that will achieve all three of the following:

1. Give excellent voltage regulation.
2. Protect the tube and amplifier against faults.
3. Survive major faults such as arcs and flashovers without damage to the regulator itself.

Two or three transistors in a simple feedback loop can make quite an effective shunt regulator⁸ but my view is that once you've taken the decision to 'go the feedback route', you might as well go all the way. With a bipolar power transistor or MOSFET as the active shunt element, controlled by an op-amp, the improvement is dramatic. Voltage fluctuations, hum and noise levels all drop to a few tens of millivolts (on a 350–400V rail!) which is better than any tetrode could possibly need. You simply don't have to worry about voltage regulation any more.

Active Shunt Regulator

The basic circuit is shown in Fig 6, and was originated by G4JZQ^{4, 5, 6}. The shunt regulator element is the power MOSFET Q1, which is fed from the unregulated power supply by resistor R1. The gate of Q1 is driven by the op-amp U1. A divided-down sample of the output voltage is fed to the non-inverting input of U1, and the inverting input is held at a stable reference voltage. To analyze how this circuit works, think what would happen if the output voltage tried to rise. Through the voltage divider R2-R3, this would cause the voltage at the non-inverting input of U1 to rise, and therefore the output voltage from U1 to the gate of Q1 would rise by a much greater amount. This would make Q1 conduct more heavily, pulling down the output voltage and compensating for its original tendency to rise. Exactly the reverse would happen if the output voltage tried to fall; Q1 would conduct less, and allow the output voltage to rise again by exactly the correct amount.

This is a very high-gain feedback loop, so it requires stabilization over a wide range of frequencies. An ordinary internally compensated op-amp is not suitable – in fact it will oscillate. The simple trick, courtesy of G4JZQ, is to use an uncompensated op-amp such as the 748 with heavy external compensation from the network R4-C1. (If you're not familiar with the 748, it's simply the good old 741 without its built-in compensation capacitor.) C2 also affects the loop's stability and HF response, as does C3 to a lesser extent. This basic circuit has shown reliable margins of stability in several variants, using both bipolar and MOSFET power transistors, and also in configurations involving much higher loop gain than shown here. To conclude the description of the feedback loop, Q1 always has to operate in its turn-on threshold region, which requires a gate voltage of about +2V. Since the output of U1 will not swing reliably down to this voltage when used with a single supply rail, the potential divider R5-R6 allows U1 to operate at a more comfortable output voltage of about +4V.

There are two reasons for using a power MOSFET at Q1 rather than the more familiar bipolar power transistor. One is the high gate impedance – MOSFETs are easy to drive at these low frequencies. The other reason is that screen-regulator usage involves an unpleasant combination of high voltage, relatively high current and high heat dissipation that can cause bipolar transistors to fail unexpectedly by a phenomenon called 'second breakdown'. Power MOSFETs are immune from second breakdown and are therefore the best choice for TR1. With a little care to avoid electrostatic damage, they are very easy to use, and are very rugged once installed in circuit. You'll like the prices too – 1000V devices rated at more than 100W dissipation at 25°C cost less than \$5 each.

The value of the HV feed resistor R1 is important. Together with the unregulated power supply it controls the maximum current available, and also the resting power dissipation in Q1. When the tetrode draws positive screen current, that current no longer flows down to ground through Q1 so its dissipation decreases. The maximum current available without losing voltage stabilization is when Q1 draws no current at all. The worst situation for power dissipation in Q1 is when the tube is continuously producing negative screen current, which Q1 must bleed away to ground in addition to the normal current supplied through R1. The maximum power dissipation is therefore:

$$(\text{regulated voltage}) \times (\text{maximum negative screen current} + \text{maximum positive screen current})$$

Fortunately not all of this power has to be dumped into Q1, because you can add a high-power resistor R7 in series to share the load. The use of R7 narrows the ranges of both positive and negative screen current that the supply can handle without losing voltage stabilization, so you need to choose the value carefully.

Flashover Protection

Up to now we've mainly been thinking about normal operation – but what happens when things go wrong? Many amateur amplifier builders seem to ignore this possibility, or resign themselves to extensive damage in the event of a major fault such as a flashover. I find this totally unacceptable. A reasonable design aim is **zero damage** from any kind of minor fault – just push the RESET button and be back on the air immediately. Even a major flashover doesn't have to result in anything worse than a blown fuse. It shouldn't be necessary to switch on the soldering iron.

Flashovers are the main cause of tube and circuit damage. If your amplifier can handle one of those, it can probably handle most other kinds of faults too. They can occur either inside or outside of the tube envelope, and can be caused by incorrect tuning, dust or bugs in the cooling air, a sudden release of gas within the tube (especially in the first few hundred hours), and sometimes there seems to be no reason at all – the amplifier just goes BANG! Whatever the reason, the effect of a flashover is to 'crowbar' the HV supply with a low-resistance arc from

the anode, which can be highly destructive. When a tetrode flashes over, an internal arc will hit the screen grid and an external arc will hit the contact ring and the socket. Then the surge current will head back towards the power supply. It is vitally important to protect all these components on a timescale of microseconds, and then to kill the arc as quickly as possible.

Whatever your views about screen supplies, the following precautions are **absolutely essential**. Most of them apply to triode amplifiers too.

- Use a current-limiting resistor in series with the HV+ supply. For a typical 2–3kV power supply, Eimac⁹ recommends a resistor that will limit the peak fault current to 40 amperes; in other words, about 50Ω. The resistor must be capable of withstanding the full HV for a few milliseconds without internal arcing, so a long-bodied 50–100W type is recommended¹⁰.
- Connect a surge voltage protector such as a voltage-dependent resistor (VDR) or a Siemens spark-gap from screen to cathode. When the arc hits, this device will conduct heavily and divert damaging current away from the tube, the screen bypass capacitor and the power supply. Surge voltage protectors cost a few dollars; tubes and sockets cost hundreds!
- Interrupt the mains supply to the HV transformer as quickly as possible, to limit the follow-through energy in the arc. Don't wait for a fuse to blow – use a fault-detection circuit to control a high-speed circuit breaker. A solid-state relay can interrupt the mains power in less than 10 milliseconds, at the next zero crossing of the AC cycle.
- Protect the meters and the HV-negative rail from the effects of the current surge (very important¹¹, but outside the scope of this article).
- Protect the screen supply – but without risk to the tube.

Fig 7 shows some bad screen circuits that are either ineffective or could actually endanger the tube¹². Many of them seem to originate from the fuzzy notion that it's more important to protect the power supply than the tube, or that you have to be willing to sacrifice either one or the other. Wrong: a good circuit will reliably protect everything!

Fig 7a has a low-current fuse. It probably won't blow reliably, and then the arc will drive the screen voltage disastrously upwards. Even if the tube survives, it will probably blow the screen bypass capacitor and total that expensive base. A surge voltage protector will definitely help, but it's only a band-aid for a fundamentally bad circuit. Fig 7b uses one or more blocking diodes to protect the zener stabilizer diodes. In normal operation this circuit has absolutely no voltage regulation against negative screen current, leading to potential DC instability and perhaps even provoking a flashover. When a flashover does happen, the circuit relies totally on the surge voltage protector. Fig 7c is rather more sensible; it uses a small relay to detect excessive screen current, but it is slow-acting and also the relay coil adds a significant resistive and inductive component to the dynamic impedance of the screen supply. Fig 7d has a 100Ω 'grid stopper' resistor, and was probably copied from circuits that were published back in the Class-C days. Unfortunately the voltage drop across the resistor degrades the screen voltage regulation. As described later, it's very simple to convert this resistor into a highly damped RF choke that has a minimal voltage drop.

Screen-Current Trip Circuit

Screen-current metering is essential in any tetrode power amplifier because it's the most reliable tune-up indicator. In addition to monitoring the screen current visually, it's very useful to monitor the current electronically as a basis for fault protection. Electronic circuits can react far faster than you can! Fig 8 shows a screen current monitor circuit that is opto-coupled and can 'float' at any voltage. The bridge rectifier BR1 makes the circuit respond to both positive

and negative screen current, and the extra resistors and the zener diode D1 are to protect the opto-isolator U1 against flashovers and short-circuits. Like the overload relay in Fig 7c, this current monitor causes a significant voltage drop, but that doesn't matter if the circuit is located inside the feedback loop of an active voltage regulator.

The opto-coupler transmits the screen-current signal to the amplifier control circuits. There are several ways to use this signal, for example to trigger a small thyristor as shown in Fig 8. The trigger point is stabilized by the voltage regulator U2 and adjusted by RV1. With the component values shown, the trigger point is adjustable for screen currents in the range $\pm 20\text{mA}$ to $\pm 40\text{mA}$. When the thyristor Q1 triggers, Q4 is biased to cutoff, and takes the amplifier off-line by removing the +24V DC supply from all relays, including the relay that grounds the screen and the two-pole mains power relay for the HV transformer. The alarm LED lights, and the thyristor Q1 remains latched in this condition until you press the RESET button SW1 (or remove power completely). If it was only a minor fault, you're back on the air as soon as you press the RESET button.

Other fault signals can be linked into the gate or anode of Q1, as shown in the sidebar to Fig 8. The gate of Q1 requires a positive input current to trigger the thyristor, and multiple inputs should be 'fanned-in' using diodes to prevent interaction. Inputs to the gate of Q1 are 'latching': once triggered, Q1 will continue to conduct until you press the RESET button. If you do not require a latching input, grounding the anode of Q1 will hold the amplifier off-line only as long as the ground connection is present. You can decide exactly how much automatic protection you want (at 3 a.m. in a contest, I want a lot!). The options include: an opto-coupled screen current monitor for a second tube; a monitor to detect control-grid current in a class-AB1 amplifier to prevent overdriving; a warm-up timer to hold the amplifier in standby mode until the cathode has reached operating temperature; and switches to indicate blower failure or excessive exhaust air temperature.

Practical Regulator Circuits

Now we're ready to look at some practical screen-regulator circuits. Fig 9 is the complete working version of Fig 6 and it also incorporates the opto-coupled current monitor of Fig 8. With the component values shown, the output voltage is adjustable in the range 350–400V. The output voltage is controlled by comparing the divided-down sample from RV1 with the +12V reference voltage provided by U2. R14 is the voltage-dropping resistor from the unregulated supply, which should be at least 30–40V higher than the stabilized output voltage. Because the voltage regulator is so effective, the unregulated supply doesn't need to be very 'stiff'. The only important consideration is that the 30–40V 'headroom' is maintained under all conditions, even on negative peaks of mains ripple at maximum current. The value of R14 depends on the 'headroom' voltage and the maximum positive screen current that the regulator must deliver. Since this is a shunt regulator, the current that flows through R14 is almost the same under all conditions; all that varies is the fraction that is either delivered to the screen grid or shunted to ground by Q1. Therefore you should adjust R14 to deliver the required current through Q1 when the regulator is disconnected from the tube.

R12 is a power resistor which takes some of the thermal load off Q1, so that the semiconductor can be mounted on a smaller heatsink. To further reduce the long-term power dissipation, the relay K1A switches the voltage regulator into a low-power mode on receive. R15 allows about 3mA to pass through Q1, which is just enough to maintain voltage regulation but allows a quick return to full power on switching to transmit. The relay K1B switches the screen to ground on receive, or whenever the fault circuit is triggered. This also takes care of the requirement to protect the screen grid of a tetrode against failure of the anode HV supply, which results in very high screen current. In the event of any such fault, K1B will quickly change over and ground the screen. In the few milliseconds while K1 is switching, the

maximum screen current is limited by R14. Likewise R14, BR1 and the protective components around the opto-coupler U1 are all rated to survive high currents until K1B opens. R4 is a permanent bleed resistor installed in the amplifier RF deck, and maintains ground continuity to the screen grid while the contacts of K1B are changing over, or in case a screen supply in a separate enclosure becomes totally disconnected from the RF deck. If R4 provides a bleed current of about 10mA when screen voltage is applied, it will also be plenty low enough to protect the screen grid while K1B is changing over. For a screen voltage of 360V, R4 should therefore be about 36k Ω , with a generous power rating of 10W to ensure cool and reliable operation.

The screen-current meter needs to display both positive and negative currents, and the 10mA bleed current through R4 means that a conventional left-hand-zero meter will read +10mA, even when the actual screen current is zero. This is a very useful feature, because it means that you can see both positive and negative screen currents without using a special center-zero meter. For example, an ordinary 0–20mA meter will display true screen currents of -10mA to +10mA, which is exactly what you need for a small tetrode. It doesn't matter if the bleed current through R4 is not quite the value you wanted; simply zero the meter using the adjustment screw when screen voltage is applied but the screen current is zero. A less desirable consequence of the current through R4 is that the screen current trip is asymmetrical. For example, if the current monitor is set to trip at ± 25 mA through BR1, a 10mA bleed current through R4 means that the circuit trips on true screen-grid currents of +15mA or -35mA. In practice this is not a problem, because most tetrodes should never approach their screen dissipation limit in normal operation. As Fig 10 shows, you can still set the asymmetrical trip limits to protect the tube.

R3 and RFC1 decouple the screen bypass capacitor C1 from the rest of the circuit. This is important to avoid any parallel resonance between C1 and the self-inductance of capacitors such as C6, which will make the screen 'live' in the HF region. For example, using an MFJ-259 I measured a strong parallel resonance at 15MHz from an Eimac SK-620A socket and the kind of plastic-film capacitor you would typically use for C6. RFC1 is made by winding about 40 turns of thin enameled wire over the body of the 100 Ω 1W resistor R3, which must be carbon or metal-film, not wirewound). Inserting this combination between C6 and the tube socket completely kills the unwanted parallel resonance without introducing any significant voltage drop.

Note the two voltage-dependent resistors (VDRs, also known as Varistors) to protect the screen voltage from being driven excessively high by an arc or flashover from the HV supply. The VDRs act in nanoseconds, giving front-line protection while the trip circuit catches up with events. VDR1 protects the tube, and VDR2 is a backup to protect the rest of the circuit. VDRs are normally rated for their nominal AC operating voltage and their energy-absorbing capability. For this application you should choose VDRs that have a guaranteed minimum turn-on voltage at least 20V above the required screen voltage, so that they will not normally conduct at all, but the turn-on voltage must not be so high that the device cannot protect the tube and screen bypass capacitor under worst-case conditions. The guaranteed minimum turn-on voltage of a VDR (1mA leakage) is the peak value of the rated AC voltage. Taking examples from the GE-MOV product line (Harris Semiconductors), the 275V AC-rated V275LA40B is suitable for screen voltages of 350–370V, and the V320LA40B for higher voltages up to about 440V. The energy-absorbing capability of these devices is 140–160 joules, which proves very adequate. In practice, these devices will give protection against repeated flashovers. Instead of VDRs you could also use similarly-rated gas discharge tubes from the Siemens range; it's largely a matter of preference and availability.

In a flashover the current pulse through the ground return to VDR2 could be as high as 30–40A, limited mainly by the resistor in the HV+ rail. If this current passes along a thin ground rail used by sensitive low-level circuitry, the voltage drop could cause component damage due

to ‘ground bounce’ (as I discovered when testing an early prototype). Therefore the ground return to VDR2 must also be the main chassis ground for the whole circuit, as shown in Fig 9. With that precaution – and the all-important current limiting resistor in the HV+ rail – this screen supply will survive repeated deliberate flashovers and ‘crowbar’ short-circuits.

A ‘Floating’ Regulator

The circuit of Fig 9 is mainly suitable for grounded-cathode configurations, because it uses the +24V DC relay supply for the op-amp U3 and the voltage reference source U2. There are many other possible DC configurations for tetrode amplifiers, involving cathode drive and various options for RF/DC grounding of the two grids¹³, but all of these require a ‘floating’ screen supply. The clever circuit of Fig 11 (again due to G4JZQ⁶) solves that problem by ‘borrowing’ power for U2 and U3 from the screen supply itself. Q2, D6 and D7 form a simple shunt-regulated supply to power the two ICs; and the shunt regulator transistor Q1 sits above this +30V rail. A level-shifting network (R20–R21) connects the output of U2 to the gate of Q1. In order to obtain a floating output, this circuit has a ‘common negative’ rail rather than the ‘chassis ground’ rail of Fig 9. To avoid destructive current surges along the negative rail and into the low-level parts of the circuit, all connections to the common negative must be routed to a single point as shown. As with the circuit of Fig 9, this version has proved highly effective and prototypes have been in use in Europe for several years.

The screen regulators in Figs 9 and 11 are both shown configured for 350–400V output. This voltage range is suitable for the vast majority of modern ceramic-metal tetrodes used by amateurs in Class AB1 or AB2, including all the tubes in the 4CX250, 4CX350, 4CX400, 4CX800 and 4CX1600 families. Consult the manufacturers’ data sheets for the most appropriate setting. For the 4CX1000 and 4CX1500 family of tubes, which may prefer a screen voltage in the range 300 to 350V, increase R6 to 16–18k Ω . With appropriate changes the same circuit should work equally well for screen voltages up to 1000V, which is about the practical limit for readily available power MOSFETs.

Conclusion

This article has been intended as a source of new ideas. The screen regulator and protection circuits described can also be used as a 'drop-in' upgrade for a wide variety of existing tetrode amplifiers. They are thoroughly tested and can survive repeated HV flashovers and 'crowbar' short-circuits. Further details and updates can be found at www/ifwtech.demon.co.uk/g3sek

There has always been some resistance to the uncomfortable fact that tetrodes are more complicated than triodes. Maybe the circuits involved are more complex than you'd like them to be, but I have explained the reasoning behind the design decisions so that you can make your own choices – and avoid some common mistakes. You only build an amplifier once, and that is the time to build in quality, security and peace of mind for all the hours of successful operating to come.

I am grateful to John Nelson, GW4FRX and Melvyn Noakes, G4JZQ for the comprehensive tetrode power supply and control units that started all these developments^{4,5,6}, and also to GW4FRX for providing the IMD test results in Fig 4. Many thanks to Mark Mandelkern, K5AM, Bill Sabin, W0IYH and Tom Rauch, W8JI for their advice on the important points to emphasize for readers in the USA.

Fig 1 - Screen-grid current can flow in either direction. (a) Screen grid intercepts some electrons, drawing positive screen current from the supply. (b) Screen grid emits more secondary electrons than it intercepts, driving negative screen current back into the

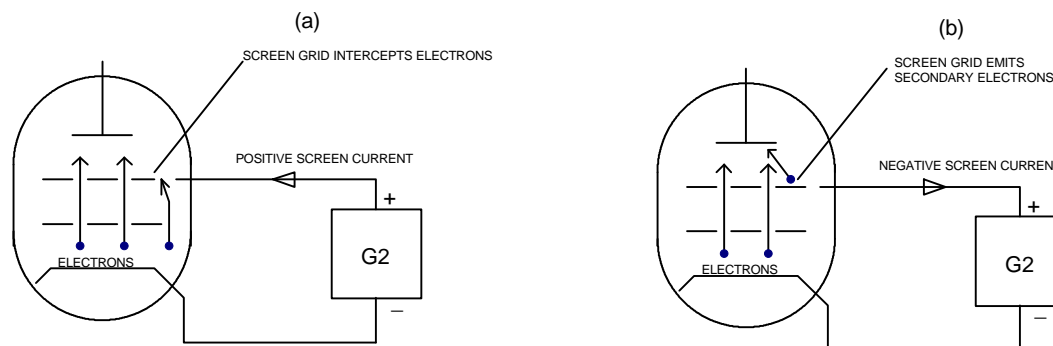

TETRODES: FIG 1

supply.

Fig 2 - Historical screen supplies: (a) Bleeder resistor gives no voltage regulation. (b) Zener diode or VR-tube regulator (zeners shown).

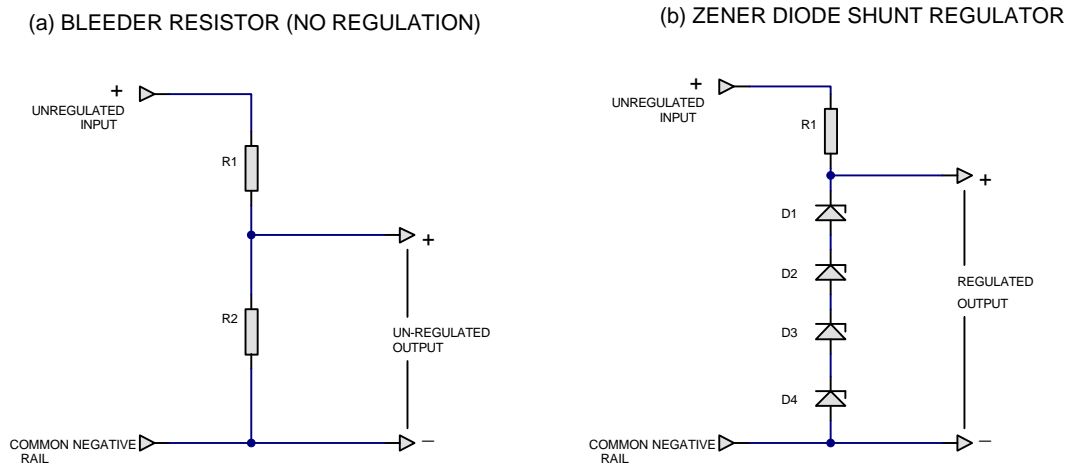

TETRODES: FIG 2

Fig 3 - The Collins 30S-1 used two separate high-current supplies for the cathode and screen, with choke-input filters but no other voltage regulation at all.

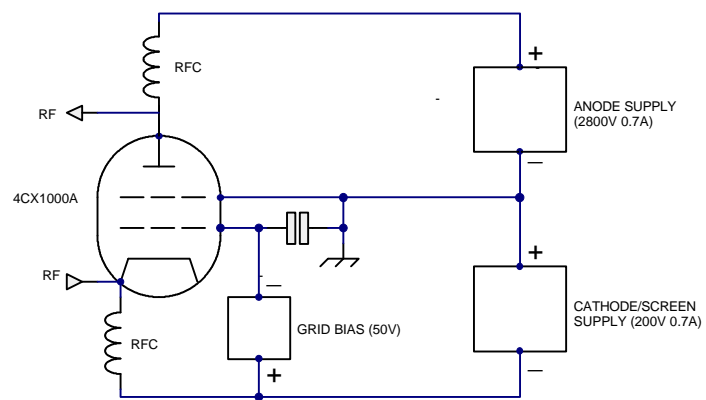

TETRODES: FIG 3

Fig 4 - Better-regulated screen supplies give lower IMD: two-tone performance of a pair of 4CX250Rs with three different screen regulators.

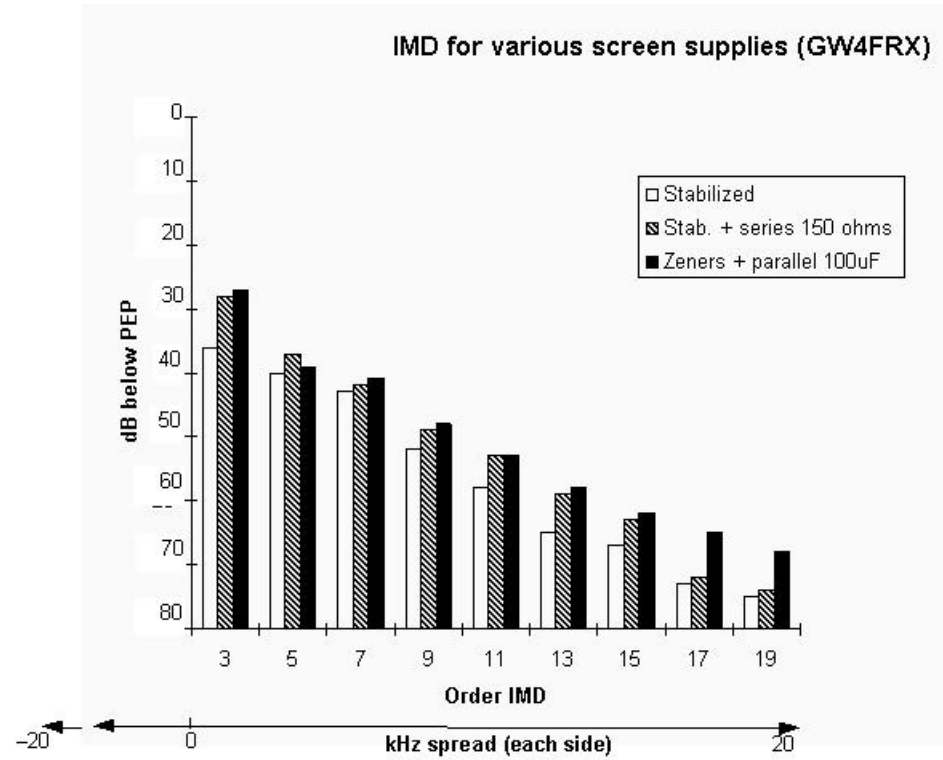
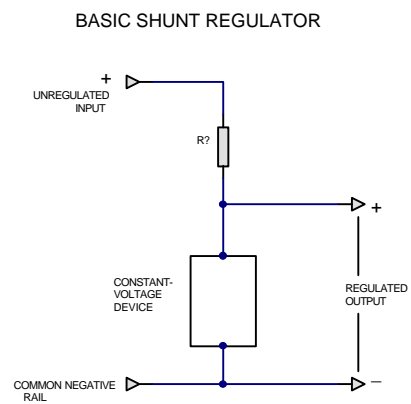
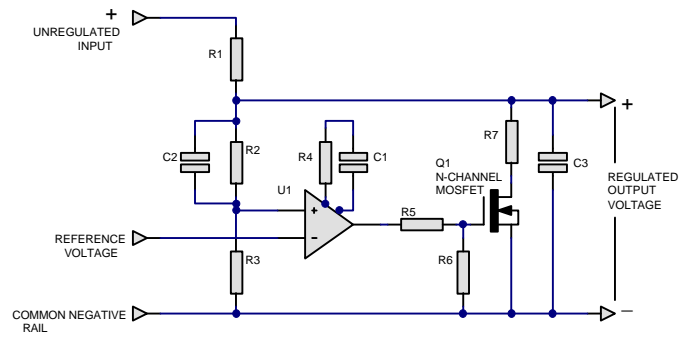

Fig 5 - Basic shunt regulator configuration.



TETRODES: FIG 5

Fig 6 - Simplified circuit of G4JZQ's active shunt regulator.



TETRODES: FIG. 6

Fig. 7 - Bad screen circuits – see text for reasons.

(a) USE NO FUSE

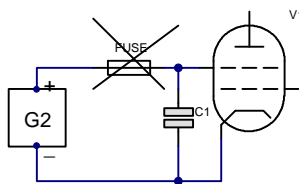

(b) USE NO BLOCKING DIODES

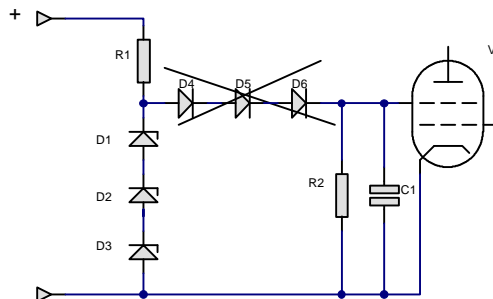

(c) AVOID EXCESS RESISTANCE

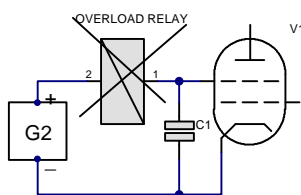

(d) WIND RF CHOKE OVER "GRID STOPPER" RESISTOR

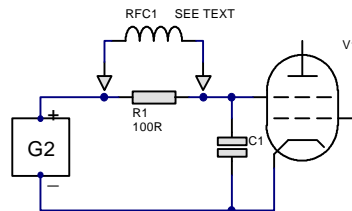

TETRODES: FIGS 7A - 7D

Fig. 8 - An opto-coupled screen current monitor and alarm circuit.

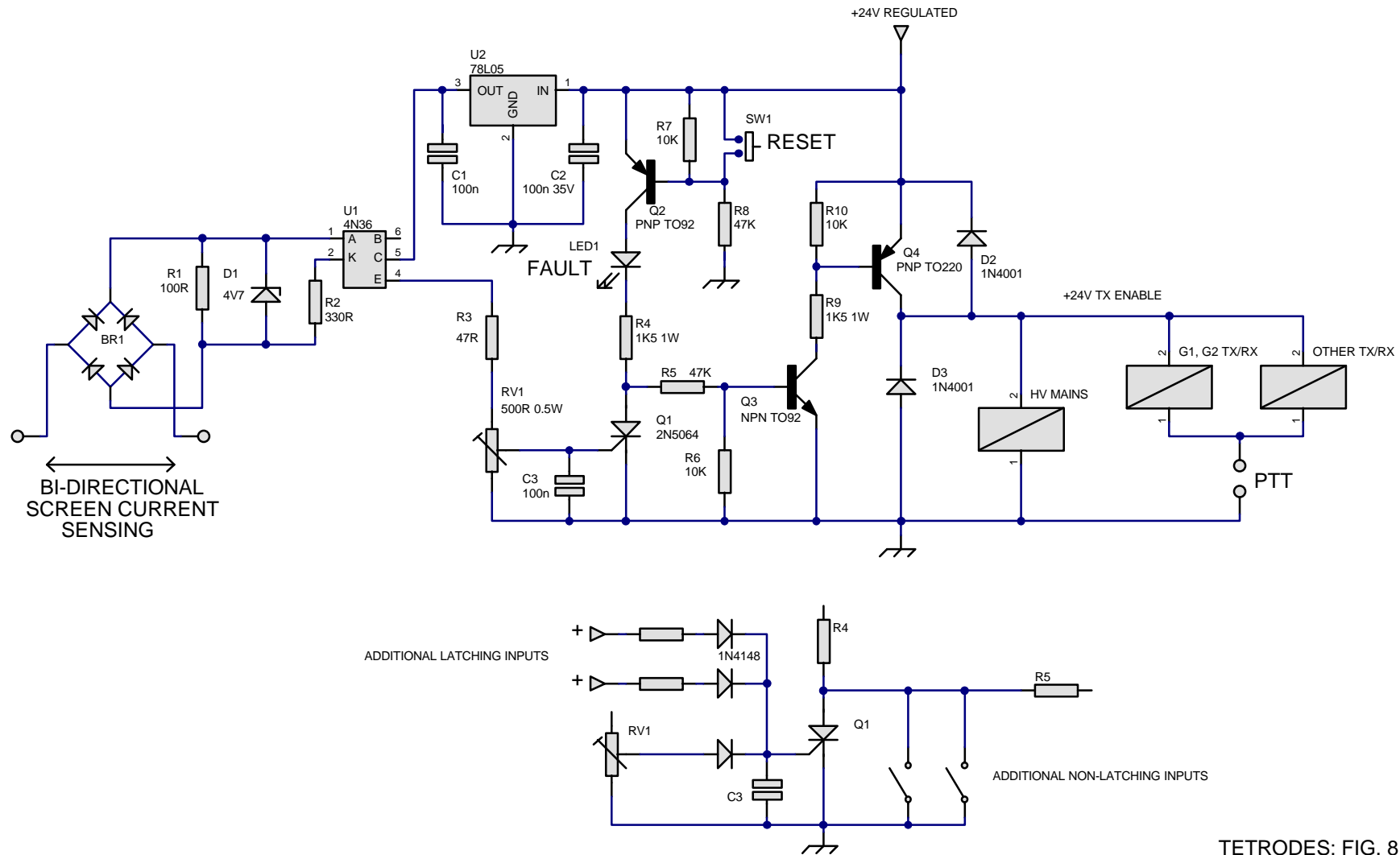

TETRODES: FIG. 8

Fig. 10 - The screen-current trip can be adjusted to cover the normal range of operation and also protect against excessive dissipation, even though the center-zero is offset from true screen current by the bleed current through R4 (Figs 9 and 11).

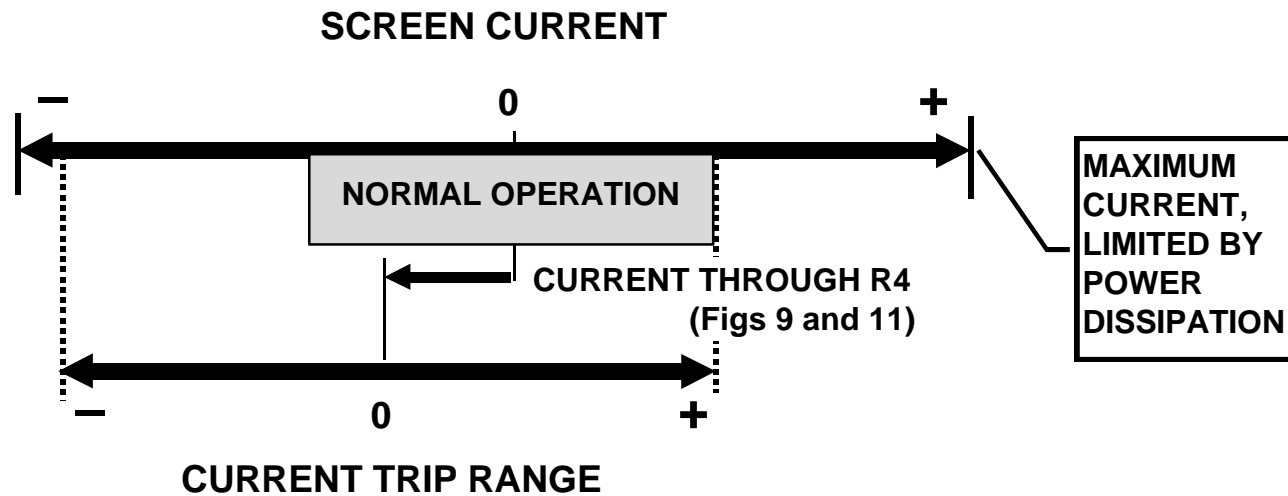

TETRODES: FIG. 9

Fig. 11 - Fully-floating 350-400V screen regulator, generating its own +30V rail for the op-amp and voltage reference.

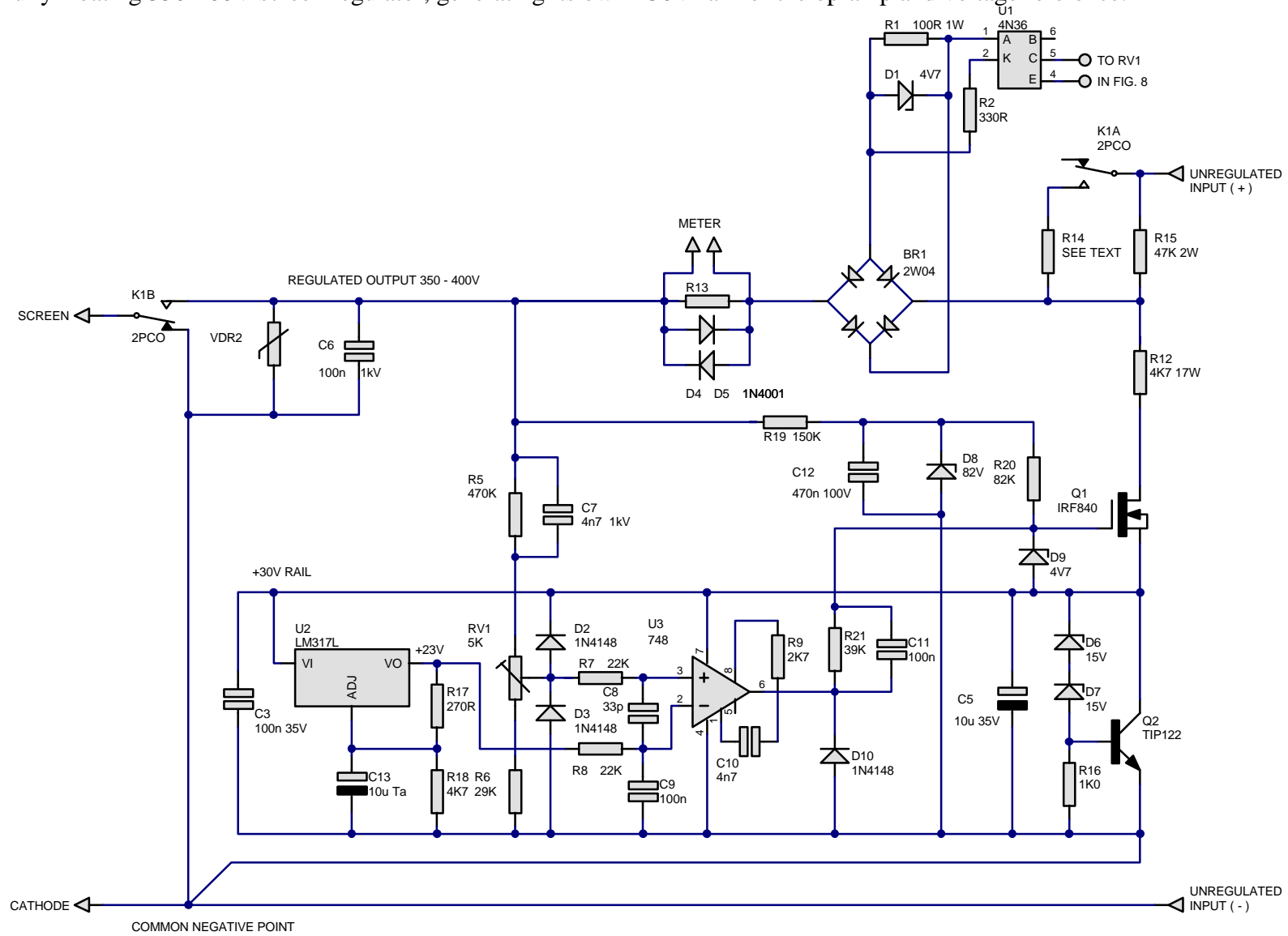

Notes and References

-
- ¹ Through most of this article I will describe circuits for a tetrode in the grid-driven, grounded cathode configuration, where the negative rail of the screen supply is connected to chassis ground.
- The use of a bleeder resistor is described in Eimac's classic *Care and Feeding of Power Grid Tubes* (1967, out of print).
- ² Bruene, Pappenfus and Schoenike, "Power Supplies for SSB Amplifiers". Chapter 15 of *Single-Sideband Principles and Circuits*. First edition, New York: McGraw Hill, 1964.
- ³ *The ARRL Handbook*, 1995 onwards: "RF Power Amplifiers and Projects".
- ⁴ Nelson, J., "A High Performance Power Supply and Control System for 4CX250/4CX250 Amplifiers", Parts I–VIII, *Short Wave Magazine*, July 1981 to February 1982.
- ⁵ Nelson, J. and Noakes, M., "A Power Supply and Control System for Tetrode Amplifiers", *Radio Communication*, December 1987 and January 1988.
- ⁶ Nelson, J., "Transmitters, Power Amplifiers and EMC" and "Power Supplies and Control Units", Chapters 6 and 11 of *The VHF/UHF DX Book*, DIR Publishing and RSGB, 1995 (available in the USA from ARRL).
- ⁷ A series voltage regulator can be used in conjunction with a shunt (bleeder) resistor to ground, but a true shunt regulator is usually more convenient.
- ⁸ Mandelkern, M., "A Luxury Linear", *QEX*, May 1996; "Design Notes for a Luxury Linear", *QEX*, November 1996.
- ⁹ "Fault Protection", Eimac Application Bulletin #17, January 1987.
- ¹⁰ G4GCM has successfully wound his own 50Ω current-limiting resistor using resistance wire on a long 1-inch diameter former, spacing adjacent turns by one wire diameter to prevent arc-over.
- ¹¹ Measures, R., "The Nearly Perfect Amplifier", *QST*, January 1994, pp 30-34. Some of the statements in this article have proved highly controversial, but it gives good advice about connecting "glitch protection" diodes to protect the meters and hold the HV-minus rail close to chassis potential in the event of a flashover.
- ¹² All of these circuits have appeared in published designs. References are omitted to avoid red faces!
- ¹³ White, I., "A Tetrode Isn't a Triode", In Practice, Radio Communication (RSGB), September 1996, p 76.