

JAN 27 1962

Preliminary TECHNICAL BULLETIN NUMBER 1010

1 kw Multi-Channel Transmitter  
TMC Model MCT-1K

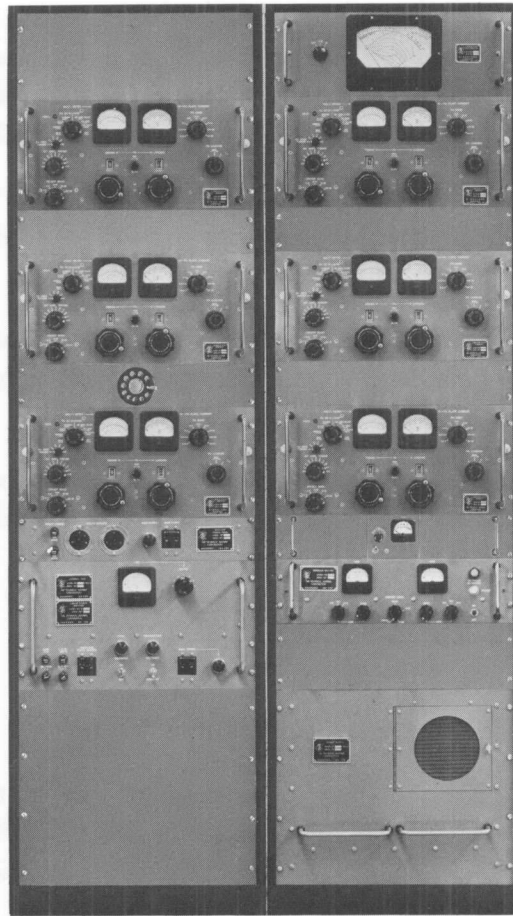

MCT-1K

TMC Model MCT-1K is a conservatively rated six channel general purpose transmitting system providing 1000 watts PEP output over the frequency range of 2 to 32 megacycles. The MCT-1K will provide SSB, ISB, AM, and CW modes of operation.

Model MCT-1K features automatic dial telephone type of channel selection of any one of 6 pre-set frequencies in less than 5 seconds. Selection of any combination of 6 individual frequency channel drawers, each fitted with two internally switched oven controlled crystals, in the following bands: 2-4 mcs, 4-8 mcs, 8-16 mcs, 16-32 mcs, provides coverage anywhere in the 2-32 mc frequency range at the option of the customer.

The equipment is housed in a dual rack cabinet 72 $\frac{1}{4}$ " high x 42" wide x 22 $\frac{1}{2}$ " deep with access provided by slides. This cabinet contains, in addition to all cabling, ducts for intake and exhaust for the power amplifier and suitable blowers to provide cooling.

Each Model RFD Linear Power Amplifier contains its own filament transformer. Output RF selection is accomplished by means of switching signal inputs and screen supply to the selected RF amplifier.

## 1 kw Multi-Channel Transmitter

A dialing unit, with appropriate relays, accomplishes all switching functions. The functions may be duplicated on a semi-remote basis by means of an auxiliary switching and dialing unit.

Many extra features contribute to the flexibility of the unit. For example, channels may be purchased in units of up to six. If antenna switching is required, a separate panel will provide switching, on an automated basis, for a properly designed antenna to any of the six RF 1 kw PEP linear amplifiers. Another separate panel (if required) will permit remote operation by means of tones. A forward and reflected power meter may also be supplied with direct or telemetered information to a remote point.

Upper and lower sideband may be used with or without carrier insertion on a direct basis, and upon special order, these functions also may be remoted.

This system may also be synthesized by substituting for the sideband generators and mixers the Model SBG-3, which will provide 100 cycle incremental tuning from 2 to 32 mcs with stability and accuracy of 1 part in  $10^8$  per day.

Single speech or keying may be accomplished over a single pair of wires on a remote basis. Dual intelligence will require an additional pair. Push to talk operation is also available, if required.

### TECHNICAL SPECIFICATIONS, MODEL MCT-1K

FREQUENCY RANGE:	2 to 32 megacycles.
MODES OF OPERATION:	Selection of any of 6 pre-set frequencies in either SSB, ISB, CW, AM, FSK and FAX operation can be incorporated by addition of the TIS-3.
OUTPUT POWER:	1000 watts PEP SSB and ISB. 1000 watts average CW, FSK, and FAX. 500 watts average AM.
OUTPUT IMPEDANCE:	50 or 70 ohms unbalanced.
FREQUENCY STABILITY:	Oven crystal control — 1 part in $10^6$ per day.
TUNING:	All controls for initial frequency set-up of the 6 channel linear amplifiers are available on the front of the units. Selection of the individual RF amplifiers accomplished by dial control either local or remote from the equipment.
SIGNAL/DISTORTION RATIO:	1. Distortion at least 40 db below either tone of a standard two tone test 2 to 22 megacycles. 2. Distortion at least 35 db below either tone of a standard two tone test 22 to 32 megacycles.

## TMC Model MCT-1K

UNWANTED SIDEBAND REJECTION:	500 cps tone at least 60 db down from full PEP output.
SPURIOUS:	50 db down from full PEP output.
CARRIER INSERTION:	-55 db to full output.
HARMONIC SUPPRESSION:	1. 2nd harmonic at least 40 db below PEP. 2. 3rd harmonic at least 50 db below PEP.
AUDIO RESPONSE:	1. CBE-1 flat within $\pm 1.5$ db 250 to 7500 cps. 2. CBE-2 flat within $\pm 1.5$ db 250 to 3300 cps.
AUDIO INPUT:	Two 600 ohm channels, balanced or unbalanced -20 dbm to +20 dbm.
HEAT DISSIPATION:	Approximately 2 kw.
ALDC:	Automatic load and Drive controls in each amplifier improve linearity, limit distortion, and maintains relatively constant output during high drive peaks or load changes.
T/R FUNCTION:	Optional at extra cost.
METERING:	Front panel meters indicate operation of all critical circuits.
ENVIRONMENTAL CONDITIONS:	Designed to operate in any ambient temperature between 0° and 50° C., and any value of humidity up to 90%.
SAFETY FEATURES:	1. Full interlock protection. 2. Full overload and fuse protection.
COOLING:	Pressurized cabinet, filtered forced air for maximum heat dissipation.
NOISE LEVEL:	-60 db from full PEP output.
INSTALLATION DATA:	SIZE: Two cabinets each 72¼" high, 20½" wide, 22½" deep.  WEIGHT: Approx. 2000 lbs.
POWER REQUIREMENTS:	115/230 volts, 50-60 cps, 1 phase Approximately 2500 watts.
SHIPPING DATA:	
COMPONENTS AND CONSTRUCTION:	All equipment manufactured in accordance with JAN/MIL specifications wherever practicable.

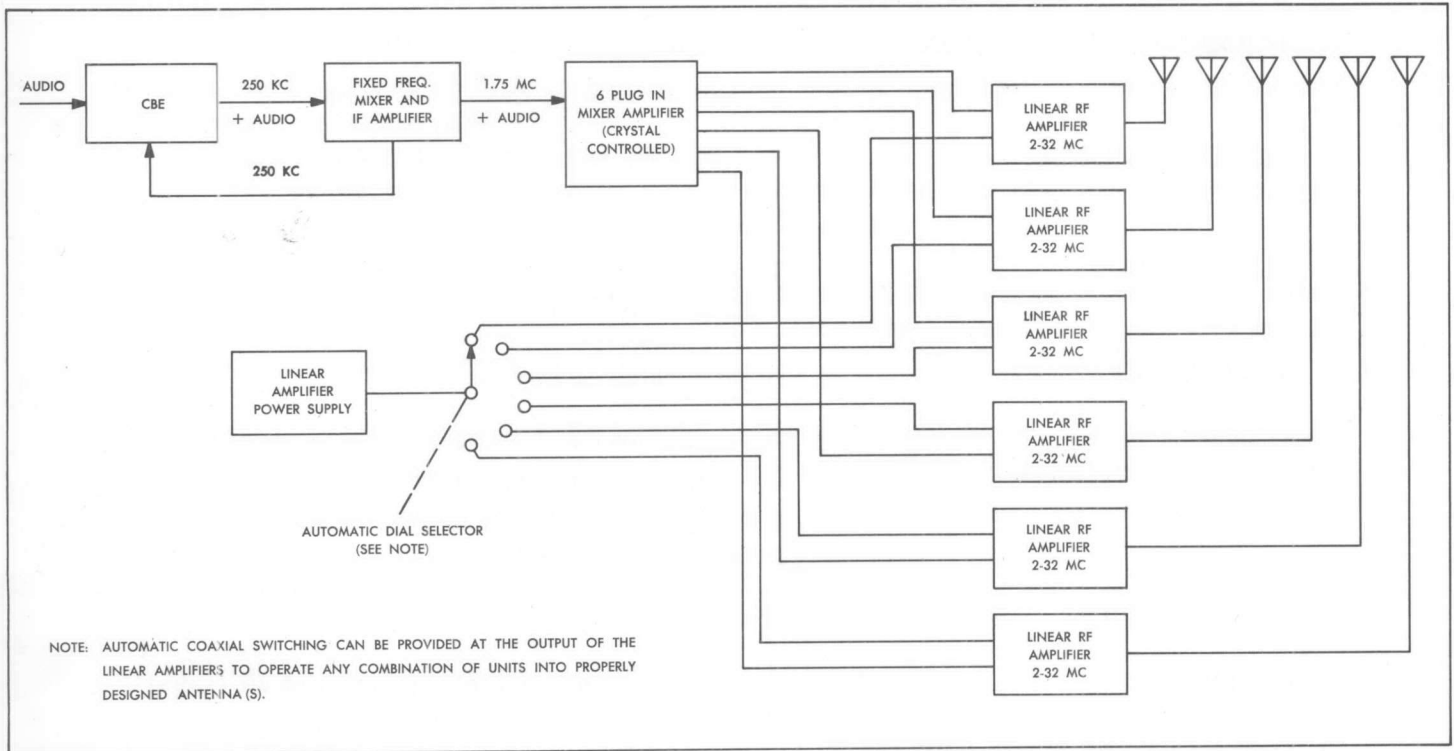

MCT-1K BLOCK DIAGRAM

Copyright 1962  
TECHNICAL MATERIEL CORPORATION

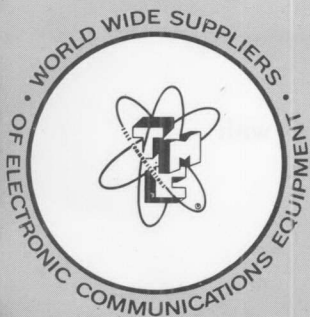

# The TECHNICAL MATERIEL CORPORATION

700 FENIMORE ROAD MAMARONECK, NEW YORK

CABLE  
TEPEI  
MAMARONECK, N.Y.

and Subsidiaries TMC (Canada) Ltd. Ottawa, Canada  
TMC Industrial Corp. Mamaroneck, N. Y.  
TMC Systems, Inc., Alexandria, Va.  
TMC Systems, (Texas), Inc., Garland, Texas