

TECHNICAL BULLETIN NUMBER 8015

Transmitting Antenna Coupler Series

TMC Models TRC

CU-729/URT



TMC MODEL TRC-500

TMC Models TRC series of Broadband RF transformers provide matching between 50 or 70 ohms unbalanced and 600 ohm balanced impedances, with power capabilities from 250 watts to 40 kw PEP.

Models TRC provide efficient coupling of RF energies from unbalanced to balanced or balanced to unbalanced over the frequency range of 2-30 megacycles, dependent on the model used.

With Model TRC Broadband coupling transformers, it is possible to match 50 or 70 ohm transmitter outputs to any antenna requiring a 600 ohm coupling; thus allowing the flexibility of RF coaxial switching at the transmitting site.

Model TRC transformers are hermetically sealed and potted in a special compound. All of the units in the series are passive devices requiring no power supplies or tuning adjustments at any time. The rugged weatherproof casings differ in construction depending on the power handling requirements of each model. No maintenance is required for these units.

Transmitting Antenna Coupler Series

All Model TRCs are provided with either Mykroy or porcelain bowls for balanced operation. All Model TRC-20Ks are furnished with a 3 $\frac{1}{8}$ " EIA flange as standard fittings, and all Model TRC-5000s are furnished with a 1 $\frac{5}{8}$ " EIA flange. All other TRCs are furnished with an AX-274 to mate with an ES-85/U coaxial connector. If other than the standard fitting is desired, please indicate by using the appropriate AX number from the chart. As an example, to order a TRC to match a 50 ohm RG-17/U cable with a QDL connector for 1000 watts PEP, order TRC-500-50U/600B/AX-273 ().†

† For mating RF cable fittings, refer to TMC Connector Products Catalog.

TECHNICAL SPECIFICATIONS FOR TMC Models TRC

FREQUENCY RANGE:	2-30 megacycles (except as noted on chart).
POWER RATING:	See Chart. (All ratings for average power based on VSWR of 2:1)
INSERTION LOSS:	Less than 1 db.
IMPEDANCES:	50 or 70 ohms unbalanced to 600 balanced. (Units may be used unbalanced to balanced or vice versa.)
RF FITTINGS:	See Chart.
MOUNTING:	See mounting diagrams.
SAFETY FEATURES:	Spark gap for protection against static charge or lightning.
DIMENSIONS:	See Chart.
WEIGHT:	See Chart.
OPERATING TEMPERATURE:	-40° C. to +75° C. Ambient.
COMPONENTS AND CONSTRUCTION:	Equipment manufactured in accordance with JAN/MIL specifications wherever practicable.

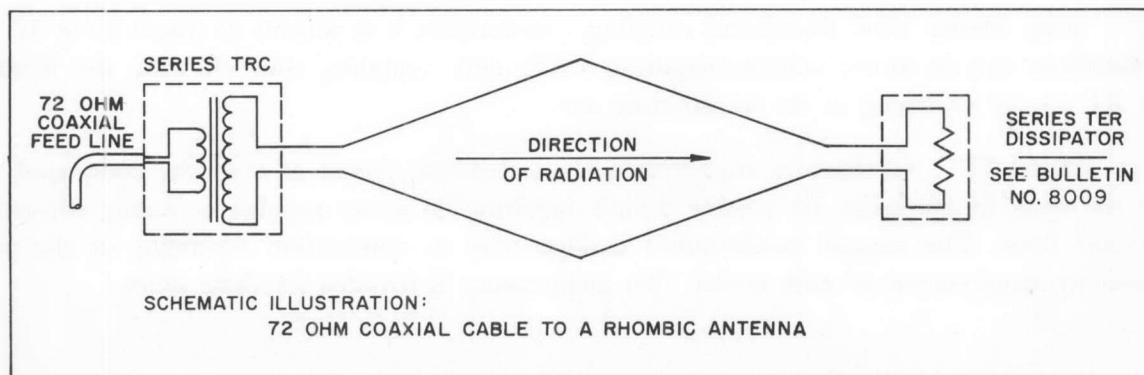

TMC MODEL NUMBER	MILITARY NOMENCLATURE	FREQUENCY RANGE (MC)	AVERAGE POWER (IN WATTS)	PEAK POWER (IN WATTS)	REFER TO NOTES	INSTALLATION DATA				SHIPPING DATA		MOUNTING PLATE CONNECTOR ASSEMBLIES*												BOWL ASSEMBLIES	LOGISTICS DATA		TMC MODEL NUMBER						
						HEIGHT (in.)	WIDTH (in.)	DEPTH (in.)	WEIGHT (lbs.)	VOLUME (cu. ft.)	WEIGHT (lbs.)	AX-274 (for RG 85/U coax)	AX-272 (500) 1 3/8" EIA Flange	AX-271 (700) 1 3/8" EIA Flange	(500) 3/8" EIA Flange	(700) 3/8" EIA Flange	AX-278 (500) 3/8" to 1 3/8" Adapter	AX-279 (700) 3/8" to 1 3/8" Adapter	AX-273 QDL	AX-281 UHF	AX-282 UHF (T)	AX-283 BN	AX-284 BNC		AX-285 HN	AX-286 C		AX-287 LC	AX-289 QDS	AX-259 N	(1/4" bolts on 12" cent.)	(1/2" bolts on 12" cent.)	A—FSN w/spare
TRC-100-70U/600B		2-32	100	200	1, 5	9	9	5	15	5	28															X	X	A				TRC-100-70U/600B	
TRC-500-50U/600B		2-30	500	1000	1, 6	9	9	5	15	5	28															X	X	A				TRC-500-50U/600B	
TRC-500-70U/600B		2-30	500	1000	1, 5	9	9	5	15	5	28															X	X	A				TRC-500-70U/600B	
TRC-3500-50U/600B		2-30	1800	3600	1	14	9	5	32	5	45	X														X	X	A				TRC-3500-50U/600B	
TRC-3500-70U/600B	CU-729/UR1	2-30	1800	3600	1	14	9	5	32	5	45		X													X	X	A				TRC-3500-70U/600B	
TRC-5000-50U/600B		2-28	5000	10,000	2, 3	14	8	5	20	5	45				X											X	X	A				TRC-5000-50U/600B	
TRC-5000-70U/600B		2-28	5000	10,000	2, 3	14	8	5	20	5	45			X												X	X	A				TRC-5000-70U/600B	
TRC-20K-50U/600B		4-30	20,000	40,000	2, 4	20 1/2	20	14	80	14	120								X								X	X	A				TRC-20K-50U/600B
TRC-20K-70U/600B		4-30	20,000	40,000	2, 4	20 1/2	20	14	80	14	120									X							X	X	A				TRC-20K-70U/600B

Indicates standard mounting plate connector assembly provided. When other fittings are desired, please use appropriate AX number. Sample: TRC-3500-50U/600B/AX-273.*

NOTES

1. Stress relieved cast Aluminum case.
 2. Fiberglass reinforced plastic case.
 3. Under conditions of a 64 tone voice frequency modulation, this TRC will operate at 50 kw PEP on a 10% duty cycle.
 4. Under conditions of a 64 tone voice frequency modulation, this TRC will operate at 100 kw PEP on a 20% duty cycle.
 5. Also tapped for 150 and 300 ohm balance.
 6. Also tapped for 100 and 200 ohm balance.
- * All mounting plate connector assemblies, other than those indicated as being provided, are sold separately.

For companion RF antenna terminators/dissipators and dummy loads, refer to TB #8009.

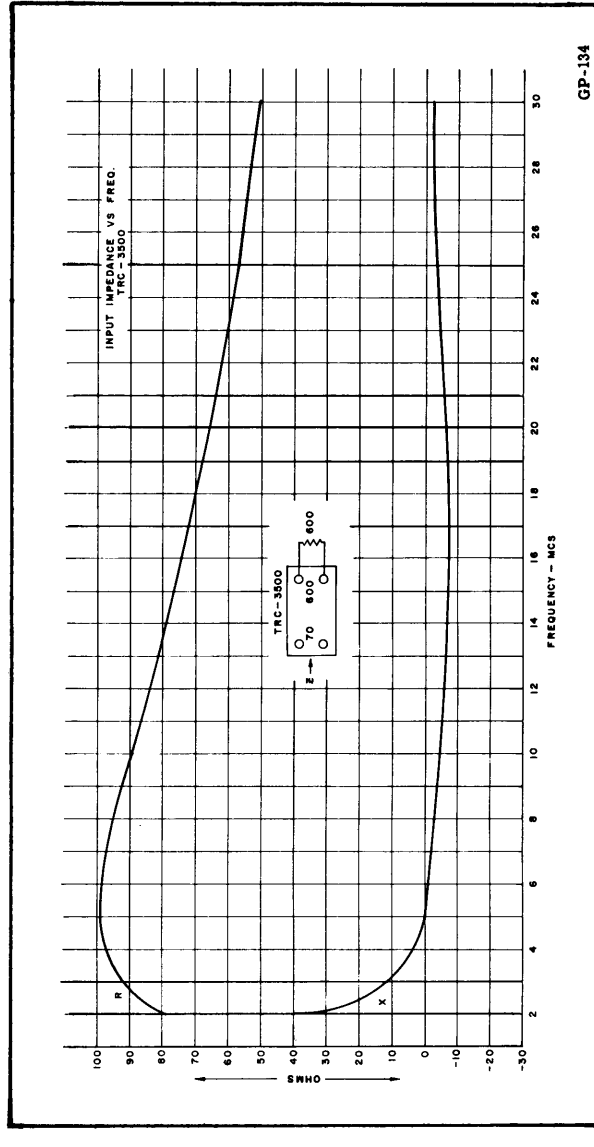

TYPICAL INPUT IMPEDANCE VS FREQUENCY CURVES, MODEL TRC-3500

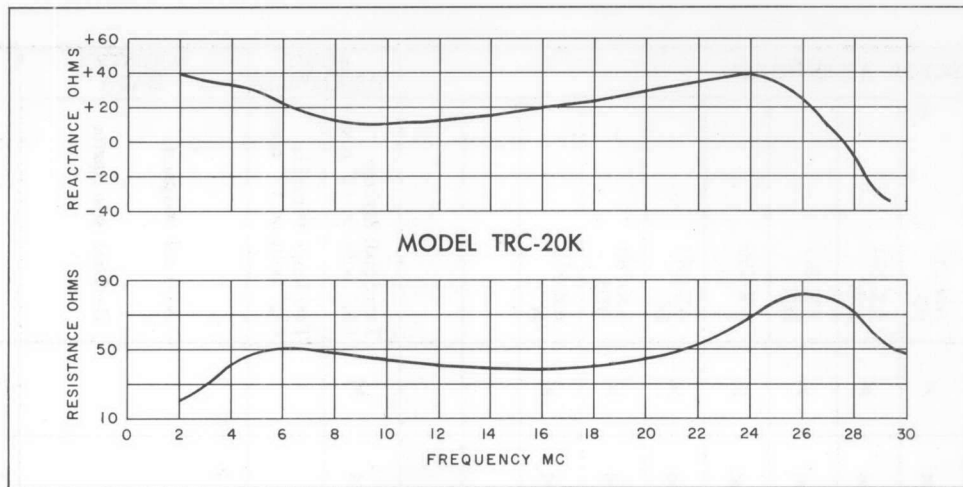

TYPICAL INPUT IMPEDANCE CHARACTERISTICS WHEN TRANSFORMER IS PROPERLY TERMINATED, IN A RESISTIVE LOAD.

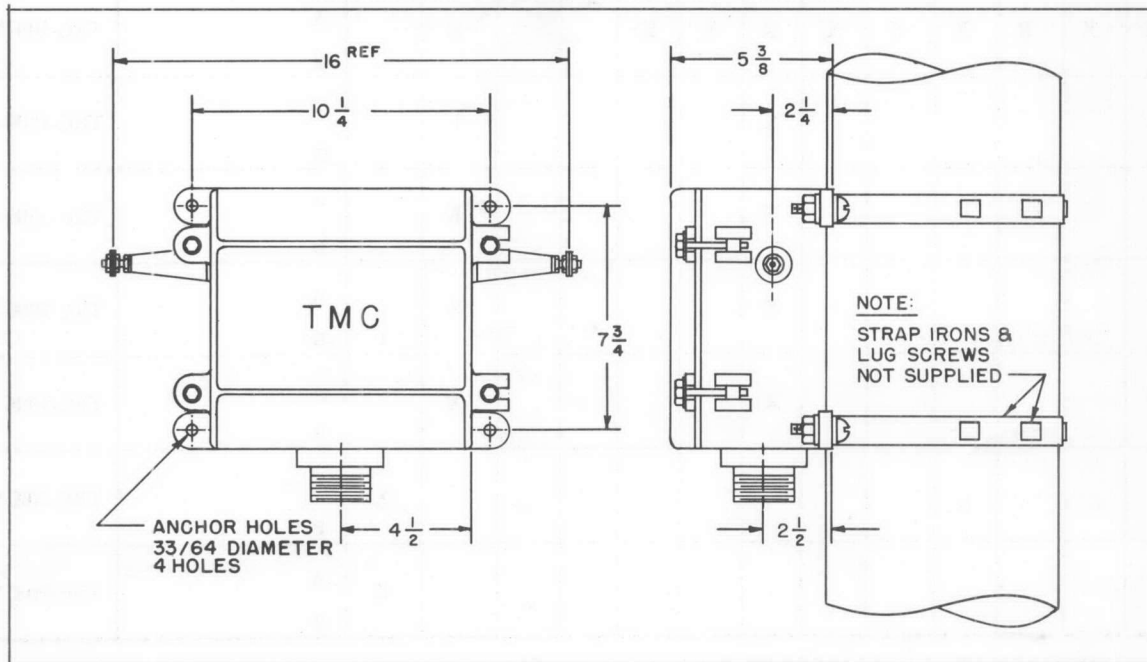

DIMENSIONAL OUTLINE AND MOUNTING, MODELS TRC-100, 500

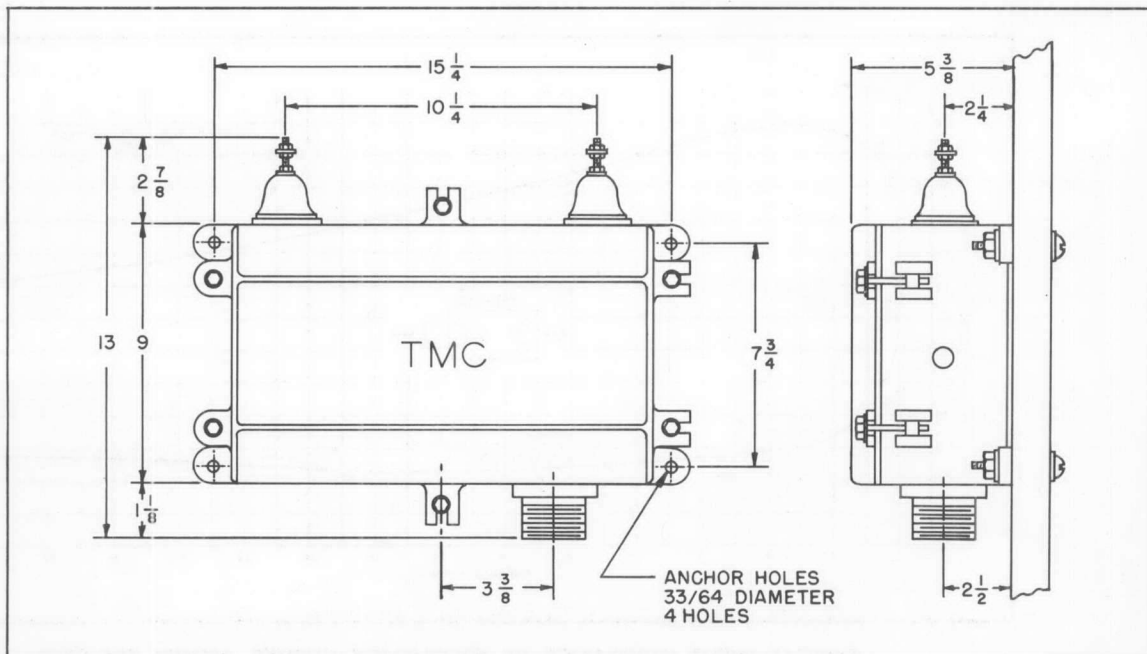

DIMENSIONAL OUTLINE AND MOUNTING, MODEL TRC-3500

COPYRIGHT
THE TECH



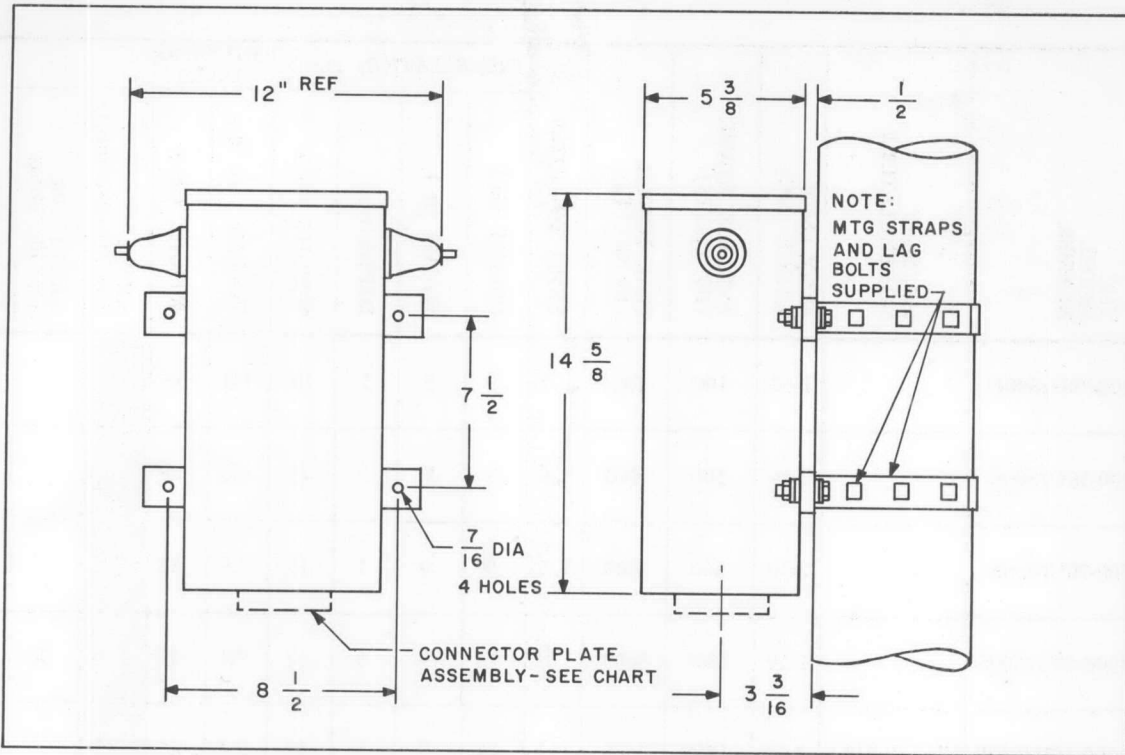

DIMENSIONAL OUTLINE AND MOUNTING, MODEL TRC-5K

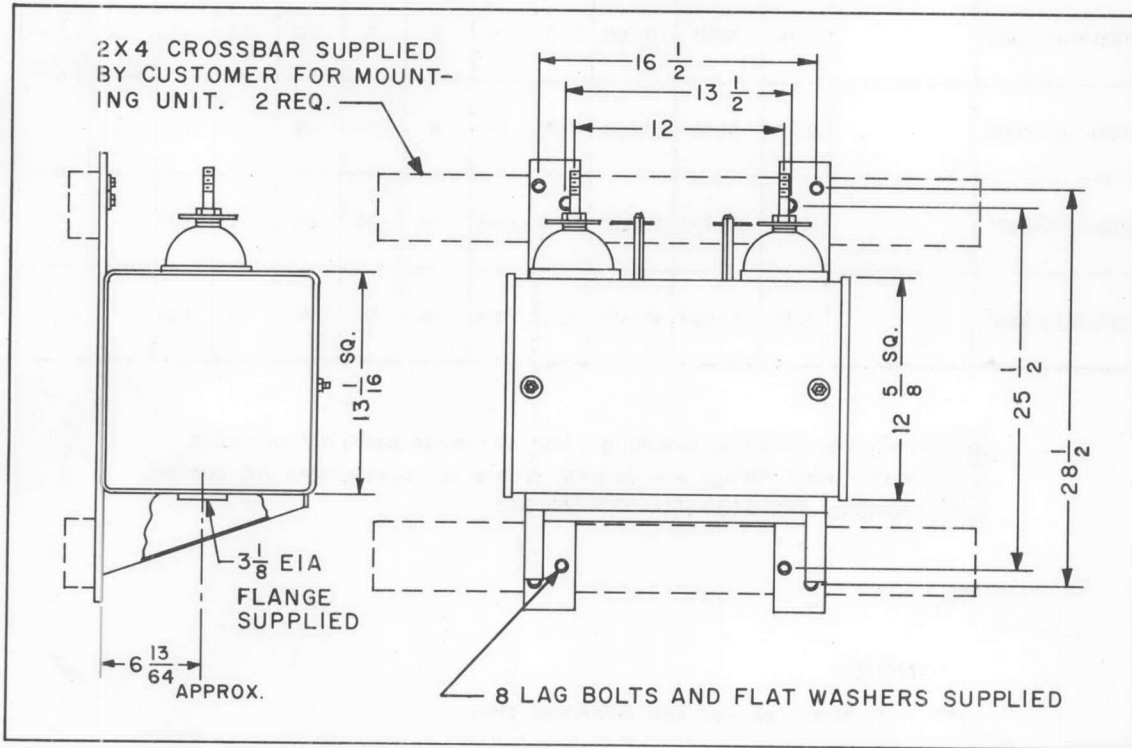

DIMENSIONAL OUTLINE AND MOUNTING, MODEL TRC-20K

COPYRIGHT 1962
THE TECHNICAL MATERIEL CORP.

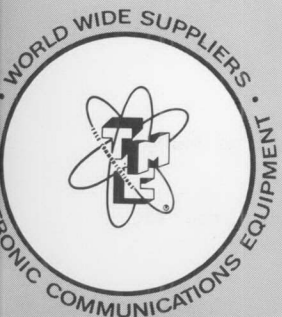

The TECHNICAL MATERIEL CORPORATION

700 FENIMORE ROAD MAMARONECK, NEW YORK

CABLE
TEPEI
MAMARONECK, N.Y.

and Subsidiaries

TMC (Canada) Ltd. Ottawa, Canada
TMC Industrial Corp. Mamaroneck, N. Y.
TMC Systems, Inc., Alexandria, Va.
TMC Systems, (Texas), Inc., Garland, Texas